

MIT LIBRARIES



3 9080 02486 5690



LIBRARY  
OF THE  
MASSACHUSETTS INSTITUTE  
OF TECHNOLOGY



The

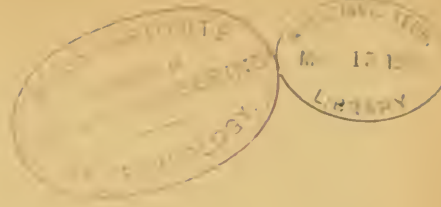

# Street Railway Gazette.

---

VOLUMES I AND II.

*Vol. I.* - - *January to December,* - - *1886.*  
*Vol. II* - - *January to December,* - - *1887.*

---

THE WRIGHT-MONROE COMPANY,

NEW YORK.

CHICAGO.

BOSTON.



Digitized by the Internet Archive  
in 2011 with funding from  
Boston Library Consortium Member Libraries

# The Street Railway Gazette.

VOL. II.

CHICAGO

JANUARY, 1887.

NEW YORK

NO. 1

## Wm. J. Richardson.

The subject of our present sketch, William James Richardson, was born in the city of Albany, N. Y., October 22, 1849, and is, therefore, in his thirty-eighth year. His early education was obtained in the experimental department of the State Normal School, at Albany, passing from the lowest to the highest class in that department. Leaving this school, he attended the Albany branch of the Bryant & Stratton series of business schools, until,—in consequence of the election of his father, Mr. Wm. Richardson, to the presidency of the Dry Dock, East Broadway and Battery Railroad Company, of New York, in the year 1864,—he removed (with his parents) to New York City. He finished his business school education in the New York branch of Bryant and Stratton's, and entered the English importing hardware business when sixteen years of age.

For a year he worked at ten dollars a month, and at the end of two years and a half was receiving twenty-five dollars a month. Few there are, probably, who begin work in life receiving less compensation for an honest day's toil than he did—in the United States, at all events. We are, of course, acquainted with the case of the trans-Atlantic Samuel Plimsoll, who worked for a considerable time for a very few shillings weekly, and ultimately rose to great distinction and philanthropic influence in the British House of Commons. And, as for that, we have some remarkable cis-Atlantic examples of prosperous men who had small beginnings, some even reaching the White House from a hut. But the most remarkable feature in Mr. Richardson's case is that he worked hard for small pay as a matter of choice, in order to learn a business thoroughly. He was not necessarily obliged to work at all; whereas Plimsoll, Garfield, etc., were driven to their lot by sheer necessity.

In 1867, Mr. Richardson left his employers to assist his father in the railroad business in Brooklyn, Mr. Richardson senior (whose "life" was published in the STREET RAILWAY GAZETTE for March last) having become the lessee, and to a large extent the proprietor, of the lines under the control of the Brooklyn & Jamaica Railway Company.

After having been so engaged for a period of two years, and desiring to devote himself to further study, and being, fortunately, enabled to do so, Mr. Richardson entered the collegiate department of the Brooklyn Polytechnic and Collegiate Institute, in which he remained three years. Upon leaving this institution, he became (in 1870, etc.) the superintendent of the Brooklyn, Carnarsie & Rockaway Beach Railroad and Steamboat Line, his father having become associated with another gentleman in leasing it. This position he filled for one year, until his father disposed of his interest in that line, when the son left the road and assisted him in connection with the business of running the lines of the Atlantic Avenue Railroad, then known as the Atlantic Avenue, East New York & Greenwood Railroad.

In May, 1872, the Atlantic Avenue Railroad Company of Brooklyn was organized, and became the successor of William Richardson, lessee, in the operation of the several street car lines under his control; and upon the organization of the said company, the subject of our sketch was elected secretary, which position he has held continuously ever since.

In 1873 he married Mary Carrington Raymond, the second daughter of John H. Raymond, LL. D., president of Vassar College, by whom he has become the happy father of six children, equally divided as to sex, all of whom are living but one. Mr. Richardson is a member of the Hanson Place Baptist Church, and is thoroughly active and prominent in connection with its progressive work, being at the present time president of the Young People's Association.

Upon the organization of the American Street-Railway Association, in 1882, he was elected secretary and treasurer; and in the following year he was elected to similar offices in the Street-Railway Association of the State of New York. To both of these offices, in each association, he has since been annually re-elected. The engraving of him, inserted herewith, gives some indication of the stuff the man is made of; and he is that sort of individual that, once he makes a friendly acquaintance, he "sticks to the last," and is a friend for ever. He was ushered into the secretaryship of the American Street-Railway Association somewhat against his



Sincerely yours,

Wm. J. Richardson.



own expectation; and the brief speech he made on that occasion, in "self-defense" against the proposal of the Committee on Constitution and By-laws, to have him appointed Secretary and Treasurer of the Association, is so suggestive of his disposition, that it may be well to reproduce it in this biographical sketch.

Mr. Richardson then said: "I think it is very proper, sir, just now, for me to say a word. In the Committee it was, although not resolved, yet well understood, that nothing that took place therein should come before this Association; yet, in justice to myself, there is one matter of which I should speak here. I had no opportunity, sir, they put my name over the road so lively, of standing up and defending myself. I had hoped that, in view of the work I had already done as Secretary of this Committee, I might be excused from any further labor during the year. I am a very busy man in my own company, and in some outside interests, and I feel, gentlemen, that it is putting too much on me. I am willing to work with any other man, but it is really asking too much of me, I feel it honestly, to ask me to do this work. If there be any other man in the room who will accept the position and let me out, I shall consider it a great kindness."

The Association balled him in, however; and at each annual meeting since, as already mentioned, they have refused to let him out of the secretarial harness, which he wears so well.

Mr. Richardson has crossed the Atlantic ocean three times—in 1870, 1883; and 1885; the first time traveling extensively on the European continent, specially interested in city passenger transportation. On his first visit to the land of his forefathers, through the kindness of Myles Fenton, Esq., then general manager of the Metropolitan Railway, of London, he was afforded special facilities for inspecting the underground system of transit in that great city.

Mr. Richardson ascribes his success in life to the care with which he attends to all the details of his business. His position requires the handling of a great many papers, and he so tries to order his work as to permanently dispose of each one as it comes into his hands, so as to avoid multiplying work unnecessarily. This systematizing principle of the National Secretary has, no doubt, contributed in no small degree to the success of the American Street-Railway Association, and is a guarantee—as long as he continues its secretary and treasurer—of the Association's future prosperity and usefulness. At all events, such is the opinion of the members themselves, as expressed by their unanimous vote of thanks to him, and as is also evidenced by the steady increase of memberships, as well as the great amount of work performed with comparative ease.

It would be ungracious, perhaps, to close this brief sketch without mentioning another "secret" to which his success and prospective usefulness may be attributed. Very much of the success or failure of a man in life is dependent upon the woman he marries. The influence of a good wife can not be over-estimated; and in having one Mr. Richardson has great reason to congratulate himself in the wise choice he made in the selection of his wife. She has, in the fullest sense of the word, been a helpmate to him; and her judgment, whether followed or not by her husband, in matters concerning his business plans and welfare, about which he takes pleasure in advising with his wife, is invariably correct. Such a wife is a treasure, and we are glad to know that her husband appreciates her. At the memorable banquet, connected with the Association's third annual meeting (two years ago), the last toast, which received a most enthusiastic response, was to "*Our wives at home—the source of inspiration of our best thoughts, the incentives to our noblest exertions, the solace of our anxious cares and the reward of our most arduous labors.*" We will not rush, however, into this holy ground,—"hallowed by the presence of the highest, the holiest, and the best gift God ever gave to man," and where angels fear to tread,—except to mention, *en passant*, that Mr. William James Richardson, of the city of homes (as well as of churches), is highly blessed in his life-companion.

## Construction, Equipment and Maintenance of American Street Railways.

BY AUGUSTINE W. WRIGHT.

(Continued from Vol. II., page 260.)

### CHAPTER IV.

#### BUILDING OF CARS.

From time to time the officials managing street railways are required to consider the matter of erecting shops in which to build their own cars, and I have been frequently asked, "Do you think it advantageous for a Street Railway Company to build its own cars?" My answer has always been in the negative, founded upon the following reasons.

A Street Railway Company is organized to transport passengers, and the more nearly it confines its efforts to this purpose, the better.

Mr. M. Kirkman wrote: "In the operation of railroads, the objective point of endeavor is the revenue that accrues from the business transacted. It is for this that the proprietors contribute money for the construction of railroads; it is for this that they are operated."

Macaulay recognized this fact when he wrote: "Now, reasoning from analogy, we should say that these great corporations would, like all other associations, be likely to attain their end most perfectly if that end were kept singly in view."

It will be conceded that railroads are not organized as manufacturers, yet in Illinois one-fifth of the total number of employees are shopmen and machinists upon the steam roads.

My friend Wm. K. Ackerman, ex-President of the "Illinois Central," operating over 2000 miles of road, contributed a most valuable paper to the *North American Review*, Dec., 1884, the result of his many years' experience and observation in divers positions, having been auditor, treasurer, president, etc., upon steam railways. Regarding the subject now under consideration, he wrote as follows:

"The establishment and maintenance of large and expensive manufacturing works by railway companies is, I believe, likely to be discontinued. Railway companies were not organized for the purpose of manufacturing, but for the special object of transporting merchandise and passengers. This is their particular business, and to this end the efforts of their managers should be specially directed. A manager charged with the care and responsibility of a railway can not afford to have his attention diverted from his legitimate vocation; he has in fact little or no time to give to the supervision of a manufactory. In the early history of railways, before large and reliable establishments for manufacturing railway equipments and supplies existed, there was doubtless a necessity for each company to control its own manufactures in order to ensure thorough workmanship and proper materials; but with the facilities now offered throughout the United States by organizations, incorporated for the express purpose of furnishing the railway companies with rolling stock and other supplies, there seems to be no longer any necessity for the railways to maintain such extensive shops. Smaller shops, with largely reduced forces, are all that would seem to be required for ordinary repairs. Before the war of the Rebellion, almost every sugar-planter in the South considered it necessary to maintain a mill on his plantation to grind his own cane. It would have been as reasonable to expect that every farmer in the North should have his own grist-mill to turn his grain into flour.

"At present in the South, under the new order of things, one sugar mill accommodates several planters, and so in regard to the railways; even one repair shop conveniently located, might be made to answer the requirements of two or three lines, and in this way, by a kind of co-operative system, the cost of even running repairs could be reduced to a minimum. But as regards new work there can be no question that it can be done now as effectually, with greater facility, and at less cost, outside of the average railway car shops. I know this does not harmonize with the views

entertained by the master mechanics and master car builders; it is quite natural that it should not, but when the question of feasibility comes to be determined in the interest of the shareholders, I do not imagine that these gentlemen will be consulted. The practical effect of the railways employing some such outside agency would be to reduce materially their working force, and in this way diminish the labors and anxieties of their managers. Nearly one-fourth of the entire force of employees on our large railways are engaged in manufacturing and repairing, and in most cases they labor under great disadvantages, and are subjected to great inconveniences, both by reason of the disposition of this force, and the character of the tools and appliances."

These opinions are worthy careful consideration.

A company investing its capital in shops and machinery with which to construct its own cars is, presumably, actuated by a desire to increase its profits, and consequently its dividends to stockholders.

The principal reasons advanced for this policy are either that the company can build *better* cars for the same money, or as good cars for *less* money.

In my opinion this is a mistaken idea, and if the truth were known, the companies would find it to be so, after having invested thousands of dollars in expensive plants.

I do not believe it to be to the pecuniary interest of any street railway to enter the domain of manufactures, and compete with individuals or firms in the building of cars.

When a company launches out into car construction, what is the result?

It is not at all probable that the president or superintendent has had any practical experience in this line of business. He therefore looks about and employs a man as master mechanic, to whom is intrusted the supervision of this department. The latter receives a fixed salary, and has no pecuniary interest in the result other than to maintain his position. He has much to contend with.

It is proverbial that the laboring classes work harder for firms and individuals than for railway companies; supply men charge the railway company a larger price for the same article. The master mechanic is human. If he was personally interested in the result of his work and every cent paid out was from his *own* pocket, can anyone doubt that he would make greater efforts to reduce the cost?

The individual or firm engaged in the business of manufacturing cars *has* this direct pecuniary interest in watching every detail. He has a reputation to establish or maintain for first-class work, and competition will ordinarily preclude excessive profits. As years roll by he accumulates a wealth of experience from his extended practice. He has employees, engaged perchance for years, working hour after hour, day after day, week after week, and month after month on the *same work*, this service having extended within my knowledge upwards of *twenty years*.

The importance of this fact as regarding the amount of work done and consequent cost thereof, has been commented upon by every writer on political economy from Adam Smith down to the present day. One half a century ago Charles Babbage, the eminent English mathematician, wrote:

"Perhaps the most important principle on which the economy of a manufacture depends is the *division of labor* amongst the persons who perform the work. . . . A certain quantity of material will be consumed unprofitably or spoiled by every person who learns an art, and as he applies himself to each new process, he will waste a certain quantity of the raw material or of the partly manufactured commodity. . . . Another source of the advantage resulting from the division of labor is that *time is always lost from changing from one occupation to another*. . . . The constant repetition of the same process necessarily produces in the workman a degree of excellence and rapidity in his particular department which is never possessed by one person who is obliged to execute many different processes. This rapidity is still further increased from the circumstance that most of the operations in factories where the division of labor is carried to a considerable extent, are paid for as piece work. . . . When each process, by which any

article is produced, is the sole occupation of one individual, his whole attention being devoted to a very limited and simple operation, any improvement in the form of his tools or in the mode of using them is much more likely to occur to his mind."

The equipment of a street railway is comparatively limited, inasmuch as no single company needs new cars enough to warrant an investment in buildings, with improved labor saving machinery, equal in extent to any of the large firms engaged in this business; and without this improved machinery, convenient and extensive shop room and arrangement, it can not compete in the manufacture.

As a matter of fact what president or superintendent of any street railway building its cars, *knows what they cost?*

The master mechanic perhaps attempts to keep an accurate account of the labor and material consumed in building a new car. The result indicates a saving, but he has neglected to add to the naked labor and material expenses incidental to the running of a shop, such as taxes, interest on the cost of plant, wear and tear of tools and machinery, interest on investment in supplies, etc. A recent well informed writer estimates these expenses at from 60 to 100 *per cent of the cost of the labor itself*.

It is well nigh impossible for the master mechanic to keep an *accurate account* of the cost of constructing a car.

In building a locomotive one of the leading firms require a list to be filled out under 429 *heads*.

The Car Builders' Dictionary illustrates 136 parts entering into the construction of a street car. In an accurate account this would be doubled by labor, etc. Does any street railway company keep such an account? Without it they do not and can not know the cost of car construction. The balance is all charged to the repair account. This causes the master mechanic to neglect repairs upon the cars running on the road, to keep shop expenses as low as possible.

In his report to the president or superintendent he gives the total running expenses of the shop, ignoring taxes, insurance and interest on the investment. He credits this account with the construction of a certain number of new cars, charged at a price less than the amount asked by car manufacturers for a similar car. The balance is charged to the repair account, and divided among those cars that may have passed through his shop. There is no check upon this account, for what general officer knows how much his repair account would have been without any new construction? He can not compare the expense of repairs per car with another company's account without personally examining the condition of each car upon both roads. The one road, without building new cars, may have expended more on repairs per car. This will, of course, show in the condition of its rolling stock, but bare figures will fail to indicate this difference.

The only real saving is in the matter of freight, if the manufacturer is not located in the same place.

I speak from experience when I affirm that as good cars in each and every respect can be purchased from the manufacturer as are or can be made by any street railway company in its own shops.

As a rule, it is best to maintain repair shops, and as work therein is apt to vary from time to time in amount, it is no doubt the part of wisdom for a company to build for its own use "open cars" when such are used (their construction is more simple, less complicated than that of "close cars") to retain its skilled labor and give it employment, when otherwise the men would have to be laid off, and might make other engagements; but one or two such cars would probably bridge over the slack times of twelve months. I might enlarge upon this subject *ad infinitum*. It is a matter of great importance to street railway companies, and to such as have not built cars I would say, consider well before entering into active competition with the manufacturer.

CARS.

Fig. No. 40 shows the first car built for a street railway. It was modeled after stage coaches, a construction also



followed in building the first passenger cars for steam railroads. This car was named "John Mason," in honor of the then president of the New York and Harlem R.R., which was operated within the city limits of New York by horse power, and was the first street railroad. It was opened in 1832. The next street railroad was not built until twenty years had elapsed. It was the Sixth Avenue of New York. John Stephenson built the "John Mason" in 1831, over half a century ago, but he is still at the head of a great business with the accumulated wealth of an experience gathered during fifty-five years.

In Brown's interesting history of "The First Locomotives in America," will be found an account of the first street railway accident, which occurred, as a matter of course, upon the first street railway. "The driver of the 'John Mason' was a well known knight of the whip, Lank O'Dell, who always drove a pair of gray horses. The first trial, or experimental trip, was a most important affair in New York. The road commenced about Prince street and the Bowery, and extended to Harlem Bridge. On this occasion the streets along the route were crowded with spectators. Two cars were ready for the occasion, Lank and his grays taking the lead, with the beautiful pioneer car, 'John Mason,' and occupied by the Mayor and members of the City Council, while the second car, driven by a hackman (his name not now remembered) and filled with some of the city officials and invited guests, brought up the rear. Great apprehensions were expressed by some of the passengers and many of the spectators, that the trouble would be in bringing these cars to a standstill at any desired point to avoid any accident that might occur in the crowded thoroughfares of the city.

"An old citizen, who witnessed this first experimental trip, related an incident that occurred on the occasion, which, though it resulted in nothing serious or fatal in its consequences, must have been ludicrous in the extreme.

"The vice-president of the road, Mr. John Lozier, being very desirous of removing all apprehensions from the minds of the doubtful, and anxious to exhibit the great facility with which the cars could be brought to a dead halt in an instant, when running at full speed, and all danger of collision with vehicles in the street rendered impossible, determined on an experiment.

"He posted O'Dell and the hack-driver of the second car to watch him, and look out for the signal, and, inviting a number of spectators to witness the experiment, he placed himself somewhere about the corner of the Bowery and Broad street. As the first car approached, he raised his arm and gave the signal to stop. O'Dell, who with his grays, had some previous practice while hauling materials in the construction of the road, performed to the admiration of the spectators, and had just come to a halt when the second car approached rapidly. The vice-president gave the signal to stop, but the hack-man, unpractised in the duty, forgot the lever (the brake), but drew hard his lines and shouted 'Whoa,' but too late—the tongue of his car went crashing through the rear of the 'John Mason,' and the Mayor and City Council beat a retreat in double quick time and in disorder from the dilapidated car, amid the laughter of the surrounding spectators. The danger over, and nobody hurt, the excursionists resumed their seats, and the cavalcade proceeded on the way toward Harlem bridge, where it arrived, without any other accident, in an incredibly short time."

This is the first street car accident on record, and was the

subject of amusement to the citizens for several weeks, and a source of great annoyance to the vice-president, especially when some wag among his acquaintances, on seeing him afterward approaching on the street, would assume his position and personate his action, by giving the signal for him to stop.

Did time permit, I would fain dwell upon the importance of the action of those New York men. Of the mighty results that have sprung from their example, the millions of dollars now invested in the street railways of this and other countries, the good return upon the capital invested, its beneficial effects upon property and general business interests, the employment it affords to many thousands, its convenience to the public, etc., etc.

In purchasing cars for a street railway many important facts merit consideration—the size, shape, finish, etc., etc. The cost varies from \$500 to \$1,500 per car, due to the foregoing reasons.

Street railway traffic depends very largely upon the frequency with which cars pass along the line. Many a would-be patron starts to walk if the car is not in sight, and has progressed so far that he will not enter the car when it overtakes him. Excepting the metropolitan lines, where the traffic is heavy, I favor the use of a small car. At nearly the same running expenses to the street railway company, double the number of cars can be provided for the use of its patrons, resulting in largely increased revenue, and convenience to the public.

John Stephenson, speaking with the accumulated experience of half a century, stated in a letter to the *American Railroad Journal*:

"No. 47 East 27th st.,  
New York,

"January 2, 1883.  
GENTLEMEN,

We regret to see that the *American Railroad Journal* is misleading the public regarding the use of small tram cars. You say the popular prejudice is strong against them 'everywhere.'

"The best statistics and sources of information accessible to us shows that in the United States and Canada there are about 428 tramways, of which Canada has about a dozen. Of these 428 roads, 279 are operated with small ('bob-tail') cars, and 149 are operated with large (conductor) cars. A reference to our order book for the year 1882 showed that two-thirds of our orders were for small cars. The small car system is a boon to the public, because: (1), Tramways accommodate the public when otherwise they could not exist; (2), The accommodation is better, because usually three small cars are used successfully when the effort to sustain two has proved a failure; (3), Economy of time equal to fifteen to twenty per cent., because the small cars make fewer stoppages, and being lighter, are stopped and put in motion more quickly; and (4), Merciful to horses. Two horses seldom start in unison. In the bob-tail car the one horse easily does the work, with better footing in the track."

The chief objection heretofore urged by the public against the use of the "bob-tail" car has been the trouble of depositing the fare in a box, at the forward end of the car. By the invention of a fare conveyor, Mr. Small has obviated this difficulty if the passenger is provided with the exact change or ticket. He or she can then place the amount of their fare in the conveyor with as little trouble as to hand it to a conductor, without leaving a seat. The "Small Conveyor" consists of metal tubes fastened to each side of the car, extending from the rear platform into a "fare box" at the front end of the car. The top of the tube contains an opening its entire length. It is inclined from

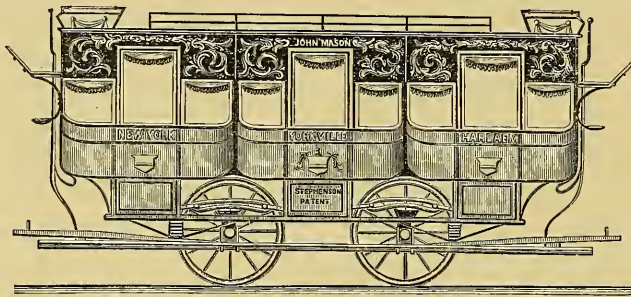

FIG. 40.

the rear to the front, so that a piece of money or a ticket of vulcanized rubber, or any hard material, acted upon by gravity, will roll forward into the fare box.

Before this invention came into use the passenger had either to walk to the forward end of the car and deposit the fare in the box, or ask fellow passengers to pass it forward, frequently to their disgust and inconvenience.

It was more or less difficult, especially for ladies, to maintain an equilibrium in the moving car. Frequently some tender "corn" was tramped upon in the effort, resulting in curses, not loud, but deep. While the passenger was taking his fare to the box some one else would frequently take his seat. All this is a thing of the past.

The advantages offered by the use of a small car, without conductor, have been clearly set forth by Mr. Stephenson. The daily saving to the street railway company is considerable, and may be approximated as follows:

DAILY ESTIMATED COST OF RUNNING 18 HOURS.	
<i>One-horse Car.</i>	<i>Two-horse Car.</i>
5 horses @ 50c.....\$2.50	10 horses @ 50c.....\$5.00
1½ driver @ \$1.75.....2.62½	1½ driver @ \$1.75.....2.62½
	1½ conductor @ \$1.75.....2.62½
\$5.12½	\$10.25

Showing an economy of 50 per cent. in daily operation. If the same number of cars are run, there is a further saving in the interest on the amount of capital invested in the larger and more expensive car, and the additional horses, stable, etc.

The use of the fare-box offers an additional advantage, inasmuch as the receipts are not handled by the driver or conductor, and less opportunity exists for speculation.

The majority of street railways, therefore, find it largely to their pecuniary interest to use "bob-tail" cars until their traffic increases to a point demanding a larger car, in their opinion. My own notion is, that many roads now running large cars, would have found it advantageous to run "bob-tail" cars, but having once used the large car and conductor, they can not change. The public demand, day by day, more and more from the street railway companies. Whether or not the company may be returning a fair profit on the capital invested, is the least of its consideration.

When the climate is so severe as in our northern latitude, and the cars are unheated, the door should be opened as little as possible, and some means should be provided by which streets could be announced by the conductor without opening the door. A slide in the door, or speaking tube, or something of the kind, would serve a useful purpose.

As the box car is not usually used in summer, it should have a closed back, without perforations, owing to the difficulty of cleaning upholstered seats. I am inclined to favor the use of a carpet, extending up to the top of the back of the seat and down in front. It can be readily removed and cleaned so often as may be necessary. The space between the floor of the car and the bottom of the seat should be closed, to prevent the drafts of cold air that otherwise strike the backs of passengers' necks, whenever the door is opened. The windows ought to be securely closed during the winter, and ventilation otherwise provided for. Everit's sash is a good invention, preventing the rattling of windows.

Castings should be provided upon the top side of the car, for carrying banners announcing attractions to invite patronage. Pins should likewise be placed on the top sides and ends of roof, for signs announcing the route of the car.

Strong eyes should be provided at each end of the car, to which to hitch an extra horse, if grades require the use of such an animal, otherwise he is hitched to the dash-board, straining it.

(To be Continued.)

"I am no longer a street car driver," he declared passionately to his girl. "My uncle has left me \$700,000, and my resignation is already in the hands of the company. When, oh, when may I call you my own?" "Some time next summer," she said, with a sweet little blush. "And why not sooner?" "Because your feet will hardly get warmed through before then, George, dear."—*New York Sun.*

### Rubber-Covered Steps for Street Cars and Elevated Railway Stations.

The application of rubber to steps is a useful improvement, inasmuch as it prevents accidents by slipping, which frequently occur with uncovered iron steps. The haste that is so generally used by passengers in getting on and off street railway cars, and also when ascending and descending elevated railway stations and bridges, makes it absolutely necessary that some means should be adopted to prevent slipping and falling. But there is danger to life and limb whenever any passenger or traveler under any circumstances, summer or winter, has to traverse a number of smooth iron steps, and whenever he gets on or off a street car or any conveyance that has a smooth, slippery, icy surface. Our street railway companies have, in some instances, taken due precautions in this matter by covering the car steps with rubber. They are observable in Chicago, New York, Boston, Cincinnati, St. Louis, and other places. These rubber-covered steps have been in constant service on some roads during the past five years, and are said to be still in good condition.

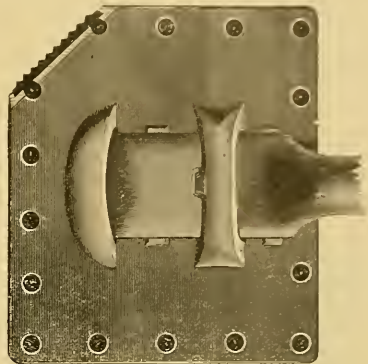

FIG. 1.

During a visit to the manufactory of the Rubber-Step Manufacturing Company of Boston, we were informed that the manner of constructing these rubber covers for iron steps is a peculiar one. Reference being made to fig. 1, the operation is described as follows:

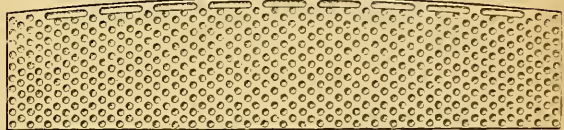

FIG. 2.

In the vulcanizing process the rubber is securely united to the step plate (made of best malleable iron) by molding it inside the wall which surrounds the plate and through the countersunk holes as shown in cut. After welding on the short shank, which is furnished, fitted to each step, the pad

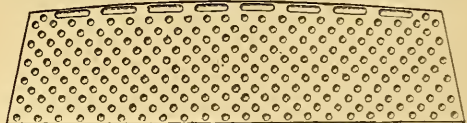

FIG. 3.

is forced into position on the shank and is locked thereon by upsetting the tongue into the depression on the back of the shank. The openings formed by the bands are wedge shape and a little smaller than the shank (which is slightly tapered), so that the bands are made to embrace the shank



tightly when the pad is forced into place. This improved construction has been adopted on all sizes of steps.

Fig. 2 is a representation of the standard size now used for treads, being twenty-four by five inches in size for thirty-three inches steps. Fig. 3 represents a size eighteen by five and a half inches for twenty-four inches steps. Fig. 4 shows another size eighteen by six inches for one horse cars (Stephenson pattern).

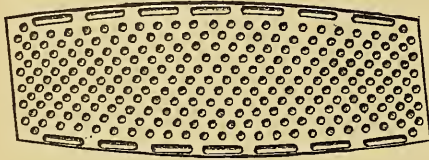

FIG. 4.

Figures 5, 6 and 7 represent some designs now used for rubber carriage steps, but which, of course, are applicable to other purposes. The rich black rubber finish of these steps gives a finished artistic effect. A worn or injured rubber covered pad is easily and readily replaced. The tongue, which locks the pad upon the shank, has only to be cut, when the pad can be driven off the shank and a new pad immediately forced on and locked as before.

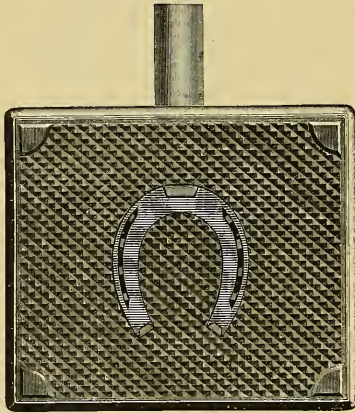

FIG. 5.

### The Enos Electric Railway.

Without engravings, it is difficult to give an adequate idea of the new elevated railroad system now being brought to public attention by the Enos' Elevated Railroad Company, of No. 2 Pemberton Square, Boston.

Speaking of it in a general way, and in allusion to some of its peculiarities, we can say, as a preparatory remark, that the inventor, some years before electricity had proved itself to be the coming power, had realized the fact and prepared for it. He claims that he has a construction now which embodies all the advantages possible. His system is one, and claimed to be the only one, that adapts itself to the accommodation of two classes of travel. It is a railway especially designed for the use of electricity as a motive power, and not converted or made over to adapt itself to electricity. It consists of a car or cars, each with its motor or power, suspended on a single track, on a single line of truss work. These cars are elevated fourteen feet from the ground, and consequently meet with no obstruction in their path. Passengers make a saving of eight feet in ascending to and descending from the cars as compared with the elevated roads in New York. This system is not governed by the law which rules all others, to-wit: that the greater the speed the greater the necessary weight of the car to keep on the track; consequently it has rolling stock of less than one-

half the weight of any other road. By thus reducing the weight of the rolling stock it can be clearly seen that the structure need not be so heavy and cumbersome.

An examination of the drawings at the company's offices, show a moderate sized post, supported by light and well constructed lateral bracing, holding a light truss span, which, while it is sufficiently strong to carry all the loads required, is yet on the whole so open and light as not to obscure the street or obstruct the view, and will meet with the minimum of objection from property holders. It must be borne in mind that this design does away with all heavy wooden guard timbers, and all cross-tie bars or sleepers, thereby not only reducing weight, but the annoyance of the lodging of snow, and particularly the droppings of melted snow. In this system the cars are over the street, and not over the sidewalk, to the annoyance of pedestrians.

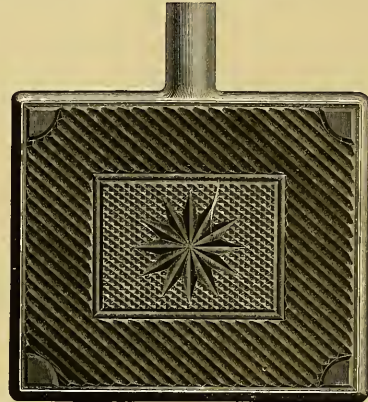

FIG. 6.

Among the advantages claimed for this system are: safety to passengers; impossibility of derailment; the center of gravity is always under the center of the rail; each car is provided with sufficient electric motive power which admits of a single coach despatch; by proper arrangements of connections it is impossible for one coach to enter a section occupied by another, thus avoiding collisions; a broken rail or open drawbridge breaks the current; great speed is attainable; it is peculiarly well adapted for city railroads.

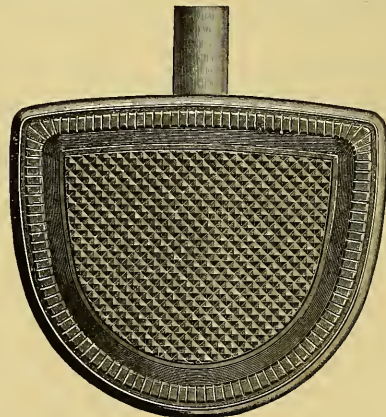

FIG. 7.

Car Driver: "You can't smoke that pipe in this car."  
Workman: "And why not?" Driver: "Because there are ladies in the car."  
Workman: "Sure, that's the very rason I want to take a whiff. I want to deaden the smell of the chape musk and patchouly."—*Texas Siftings*.

**New Crossing for Street Railroads.**

Doctor W. T. Shannon, of Brooklyn, N. Y., has invented and patented a new form of crossing for street railroad tracks, which has attracted considerable attention from parties interested. The crossing is designed to avoid the jar at the intersection of the rails at track crossings, which is so unpleasant to passengers, and so destructive to both track and rolling stock, and which is caused by the passage of the wheels across the gap necessarily left for the passage of the flanges of wheels of cars on the other track. In the new design, the cars travel over the crossings on the wheel flanges; but the car preserves the same level throughout. The principle is the raising of the bottom of the rail to engage with the flange of the wheel. An objection which has been urged has been against running the car on the wheel flanges; but, considering that cars get off the track, and are hauled over rough stone paving not infrequently, with scarcely ever any injury to the wheel flange, it is reasonable to presume that

rails, at which point, the bottom of the rail being inclined up to reach the wheel flange, both tread and flange of the wheel are supported by the rail; a further motion of the wheel causes the tread to leave the rail, which is beveled downward, and the wheel travels on its flange over the crossing, to beyond the intersection of the tracks, when the tread engages again with the rail, and the bottom of the rail is inclined down so as to be again clear of the flange. Thus the car passes the crossing without changing its level. Wear will not effect the operation; if the flange is worn, the wheel will continue to travel on the tread a little longer, and should the tread be worn, the flange will take a bearing on the bottom of the rail a little sooner. With the continuous groove form the head is not beveled down, but maintains its normal level; only the bottom of the groove is raised, the wheel running over the crossing with both tread and flange in contact with the rail. In the models the passage is made without perceptible shock at the point of transfer from tread to flange.

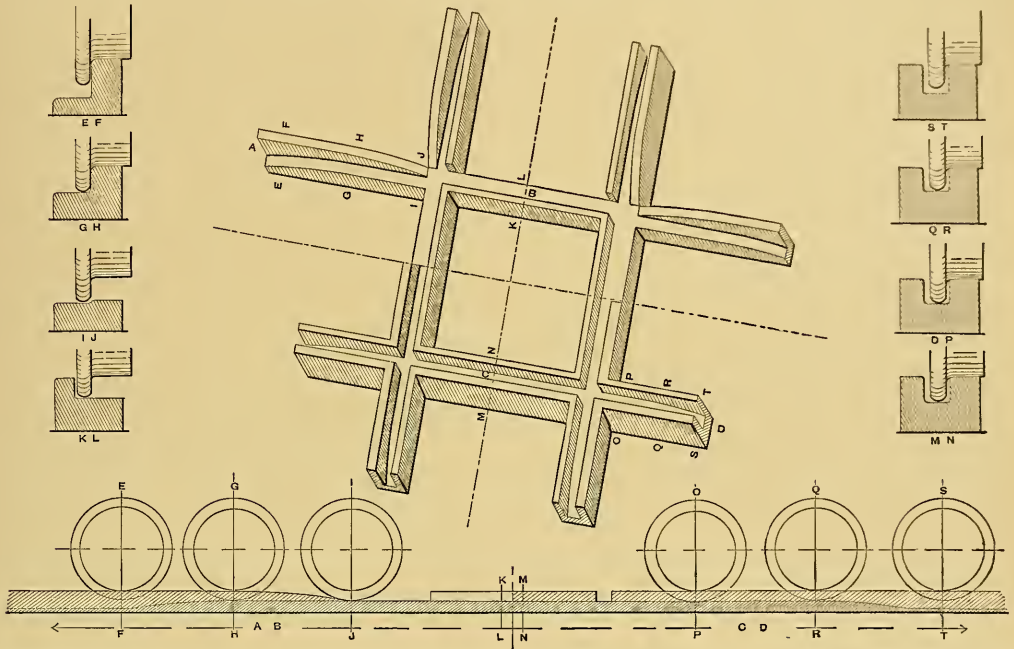

the flanges will not give trouble in running over a smooth iron track for a short distance, and as to wear, the tread would be worn out before the flange, while the absence of injury to the track and rolling stock by pounding the rail ends at each gap, and battering the wheels and shaking the frame-work of the car must be taken into account. It is applicable to any section of rail, and any angle of crossing; it may be of iron or steel, and cast in one or four pieces, and being about the ordinary weight, would be about the same cost as those of the present destructive type.

The construction is plainly shown in the illustration, which is drawn to a distorted scale in order to make the action clear. The upper half of the plan and the sections on the left hand (A B, E F, G H, I J, K L) represent the form of crossing suited to the ordinary style of track in this country, with side-bearing and channel rails; the lower section of the plan and the sections on the right (C D, M N, O P, Q R, S T) represent the form adapted to European tracks, where a continuous groove is required to accord with the grooved rail, and to which the paving sets are placed quite close, to form an even road surface. The operation of the device is as follows. The tread of the wheel travels on the head of the rail until it reaches a point near the intersection of the

It is estimated that the crossing will effect a saving in maintenance and repairs, and will act efficiently and without trouble; it will give a steady and even passage to the car, avoid jar to the track and wheels, and will prove an arrangement conducive to the comfort of passengers; and, besides this, it compares favorably in point of cost and economy with present crossings; and it has received flattering commendations, it is said, from engineers, superintendents, and practical street railroad men; and certainly such an arrangement deserves a trial. This "crossing" has been patented in this country and in Europe.

THE *Mexican Trade Journal* is the name of a new Chicago monthly, devoted, as its name indicates, to the interests of the traffic and commerce between the United States and our next door neighbor. It is a carefully edited and neatly printed quarto, the matter being duplicated in English and Spanish, and in our opinion a move in the right direction. The tendency and requirements of the age in journals of this sort being to narrow the lines, hence a journal devoted solely to the trade between two countries, and including only such chosen facts, cannot fail, if properly conducted, to become a valuable medium.



## History of Street Railways.

(Continued.)

No sooner had the street railway car become "a necessity" in New York, and adopted in Boston and Philadelphia, than the system was tried in other cities of the Union, and spread rapidly—but not without opposition, as already remarked. "Popular prejudice is the great enemy with which the advocates of innovation have had to combat," and "the more useful the measure advocated, the greater has been the amount of opposition brought to bear against it." So has it been with street railways.

### III.—THE OMNIBUS *vs.* STREET RAILWAYS.

The principal material stumbling block which the city horse roads of Philadelphia (as well as those of most other American cities) had to overcome, was the omnibus, and the purchase of the "omnibus interests" absorbed considerable capital from street railway promoters. The following correspondence, which was published in a Philadelphia newspaper, when the street cars appeared in the Quaker city, is given as an illustration of the spirit and the "arguments" which attacked them:

#### "THE OMNIBUS *vs.* THE CITY RAILROADS.

"Since the progressionists have made it fashionable to turn all our streets into railroads, and to cry down the omnibus, I wish to say a word in behalf of the latter. It will, I hope, be a long while before the citizens of Philadelphia will be contented to endure such a nuisance as the railroad is likely to be. Look at the Third street, the Market street, the Broad street, and the Willow street railroads. Are they not unmitigated nuisances? Everybody knows they are, and yet a set of speculators would make all the streets in the city just like these, to the inconvenience of the public, and to the damage of property. What is the use of experience, if we go directly counter to the lessons it teaches? Who would believe that any set of men could be found, so desperate, and so defiant of the sense of the public on this question, as to insist upon laying a railroad in two of the best streets in the city, viz.: Chestnut and Walnut streets? Yet it is so. A charter has actually been granted to a company to perpetrate this great outrage, and it is likely to be accomplished, unless the people speak out.

"I am an omnibus man, and am opposed to railroads; and while I am content to remedy any defects of the present omnibus system, I protest against their being driven out of the streets. Let us consider what are the objections to the omnibus, and suggest the remedy. It is said, and the charge, I confess, has some weight, that, in Chestnut street particularly, they occupy the entire street, lumbering about, careless of all other vehicles, first on one side, then on the other, so that it is dangerous to attempt to drive a private carriage through the street at all. Let us learn wisdom of our enemies. It would be certainly desirable, if practicable, to compel all the omnibus drivers—a very reliable and compliant set of men—to keep their unwieldy machines exactly in the middle of the street, imitating in this respect the railroad. If this were done, then everybody would know how to pass them. Fast young men and tigers could show their skill in driving their light wagons within an inch of the omnibus, on a full trot, without danger of being crushed, as now, by a lee-lurch of the great battering ram. To insure this end, I would pass an ordinance, and impose a fine upon every Jehu that did not comply with the rule. It may be objected that the drivers could not, if they would, keep the exact middle line of the street. I am ready to meet this objection. Take two metal bars, nearly flat, and lay them at a proper distance apart, so that the wheels could travel on them; the horses would naturally keep between them. This would have the effect, also, of diminishing the terrible noise the vehicle now makes over the rough stones. To prevent the wheels running off the metal bars or slabs, a slight projection might be made on each, say about seven-eighths of an inch high, and, if you please, let the wheels have a corresponding rim on their tires. This device, as any one may see, would effectually prevent the omnibus from waddling from curve to curve, and surging through holes and over loose stones. It is evident, too, that, ow-

ing to the ease with which great weights may be pulled over smooth surfaces, a desirable modification of the present bus may be made. The wheels can be much smaller, and the frame let down lower, so that feeble persons and children may be able to use this mode of conveyance, to which they have hitherto been almost debarred, owing to the difficulty of ascent to the back door. The omnibus could also be much enlarged, without increasing its weight—thus affording room for a greater number of passengers—a very important matter on a hot summer day, and when it is raining.

"I think I discover a smile on the lips of the scorner of my proposed improvement, inasmuch as I have provided for the omnibus keeping the exact centre of the street, but not for their passing each other in opposite directions. I anticipate the sneering criticism, and have the remedy at hand. I am not ashamed to avail myself of a good idea, although it comes from the enemy. Let all the omnibuses run up Chestnut street and down Walnut, or vice versa, completing the circuit by using the cross streets at either end. The system will then be complete; and with this improvement easily brought about, I defy the opponents of the omnibus to point out a single remaining objection. Why then insist upon having railroads, when it is well-known there are so many respectable people opposed to them, so that the very name is detestable. Witness the immense list of remonstrances against the Chestnut and Walnut street Company laying rails in those streets. The improved omnibus system will satisfy the entire community. Nine out of ten of these remonstrants will, if they have the opportunity, petition Councils to adopt my plan, in the place of the horrid railroad. No one will be silly enough to assert that this system will injure the property of those living on the streets where it is introduced; on the contrary, it will enhance the value of it. All complaints against the old rudderless monster—as I once heard a malicious railroad man call that highly respectable public vehicle, the omnibus—will be at an end; and it will hardly be recognized by its old admirers in its improved shape and parts.

"Again, the railroad in the hand of a company is a perfect monopoly; and although their advocates boast that they help the income of the city treasury, and diminish the taxes, by keeping the streets in good repair at their own expense, yet the people very properly object to monopolies. Now, there is no reason why a revenue of the same sort, and a stipulation to keep the streets in order, may not be equally well secured under my proposed new omnibus system. Charge twenty-five dollars per annum for the privilege of each omnibus, and compel the owners to keep the streets in order. This could not, perhaps, be done, without concert of action between the several owners; but to insure its being carried out, I would suggest that a number of individuals club together, and take certain streets, and that councils recognize the club, and hold them jointly responsible. This would be a very different concern from an incorporated company. The former consists of individual citizens; the latter is a monopoly and have the right, by an act of the legislature, to use a great seal.

"Of course, the railroad advocates will find, or try to invent, some objections to my plan; but I appeal to every reflecting man, if it does not possess all the merits claimed for the railroad, and at the same time preserve all the good characteristics of the omnibus, with none of its disadvantages. Gentlemen in their private carriages may then have some satisfaction in driving through Chestnut street. There will be no more noise, no blocking the street; people may converse and read newspapers in the omnibus; ladies' dresses will not be splashed with dirty water from the gutters; the streets will be inviting; shopping will be pleasant pastime, and everybody will be pleased with the change.

"Thus, I have proved that we can do without the railroad. Some one may say, 'a rose by any other name will smell as sweet;' but people will have their fancies, their notions, or, if you please, their prejudices. Let no one do unnecessary violence to them. If my improved omnibus system will answer, and satisfy both parties, why insist upon having a railroad? Let the streets be used for what they were intended for.

OMNIBUS."

Besides the opposition of "vested interests," prejudice against innovation combined to confront the adoption of street railways. The same elements are still at work; they are strikingly manifested in the strenuous opposition to the introduction of new street railways in Chicago—they prevented the running of the surface line on Adams street, until the law helped the Chicago Passenger Railway Co. out of their difficulty by ruling that the consent of property owners is unnecessary; they more recently essayed to bring the cable system of President Yerkes all to naught, and annihilated the new North Chicago City Railway Co.; and now they malignantly oppose the projected elevated railways in the Garden City.

This kind of opposition is not new; it was an element which conduced the murder of Abel. George Stephenson found far more difficulty in overcoming it than in constructing a railway over Chat Moss. It was amusing to notice how it was demonstrated when stage coaches were introduced. Like the omnibus, its predecessor, the stage coach, had its day between the sixteenth century and the age of railways. And as the stage coach is very nearly related to the city omnibus, both of which have been elbowed out by railways, it may not be uninteresting to give a brief account of its brilliant career; and a sketch of its battles with vested interests, combined with prejudice, may be as instructive as it is amusing, as given in Chambers' Information for the people:

The word *coach* is Hungarian, and the vehicle itself is supposed to have originated in Hungary. Germany certainly appears to have taken the precedence of the nations of Western Europe in using coaches. They were introduced thence into England some time in the sixteenth century, but were, after all, so little in vogue throughout the whole reign of Elizabeth, that there is no trace of her having ever used one. Lord Grey de Wilton, who died in 1593, introduced a coach into Ireland, the first ever used in that country. One was introduced into Scotland—we rather think from France—about the year 1571. It belonged to the famous Secretary Maitland of Lethington, who, during the horrid civil war between the adherents of Mary and those of her son James, made a journey in that vehicle from Edinburgh Castle, which he was holding out for the queen, to Niddry in West Lothian, for the purpose of holding a consultation with some others of her friends—the first time, it is believed, that a close carriage was ever used in Scotland. Fynes Morison, who wrote in the year 1617, speaks of coaches as recently introduced, and still rare in Scotland. For a long time, these conveniences were only used by old people, who could not well bear riding. The young and active despised them, as tending to effeminacy, and as not being so quick of movement as the horse. The Duke of Buckingham, in 1619, first used a coach with six horses—a piece of pomp which the Duke of Northumberland thought proper to ridicule by setting up one with eight. Charles I. was the first British sovereign who had a state carriage. Although Henri IV. was killed in a coach—the only one, by the way, he possessed—his ordinary way of appearing in the streets of Paris was on horseback, with a large cloak strapped on behind, to be used in case of rain. In Scotland, previous to the time of the civil war, coaches were only used by persons high in the state. It is very curious to find that the same sort of complaints now made by persons interested in coaching respecting the introduction of steam-locomotives, were made when coaches were introduced. Taylor, the water-poet, complains, in the reign of Charles I., that large retinues of men were now given up by the great, since they had begun to use coaches. Ten, twenty, thirty, fifty, yea a hundred proper serving men, were transformed, he says, into two or three animals. The old-wifical thinkers of that day were as much concerned about the fate of the discharged men-servants, as the twaddlers of the present are distressed about the needless horses. It is further very amusing to find Taylor, in his antipathy to coaches, complaining that their drivers were all of them hard drinkers.

In a pamphlet called the "Grand Concern of England Explained," published in 1673, the writer very gravely attempts to make out that the introduction of coaches was

ruining the trade of England. The following is an example of his mode of reasoning: "Before the coaches were set up, travelers rode on horseback, and men had boots, spurs, saddles, bridles, saddle-cloths, and good riding-suits, coats and cloaks, stockings and hats, whereby the wool and leather of the kingdom were consumed. Besides, most gentlemen when they traveled on horseback used to ride with swords, belts, pistols, holsters, portmanteaus, and hat-cases, which in these coaches they have little or no occasion for. For when they rode on horseback they rode in one suit, and carried another to wear when they came to their journey's end, or lay by the way; but in coaches they ride in a silk suit, with an Indian gown, with a sash, silk stockings, and the beaver hats men ride in, and carry no other with them. This is because they escape the wet and dirt which on horseback they can not avoid; whereas in two or three journeys on horseback, these clothes and hats were wont to be spoiled; which done, they were forced to have new very often, and that increased the consumption of manufacture. If they were women that traveled, they used to have safeguards and hoods, side-saddles and pillions, with strappings, saddle or pillion cloths, which, for the most part, were laced and embroidered; to the making of which there went many several trades, now ruined." But the writer has other reasons to urge against coach traveling. "Those who travel in this manner," he observes, "become weary and listless when they ride a few miles, unwilling to get on horseback, and unable to endure frost, snow, or rain, or to lodge in the fields."

These, however, do not exhaust the patriotic clamors of the writer against the odious innovation of stage-coaching. He says that the practice "discourages the breed of horses," an argument which, it is amusing to observe, has also been used in opposition to the introduction of railways in recent times. In certain very peculiar circumstances, he allows, stage-coaching might be tolerated, but in no other. "If some few stage-coaches were continued, to wit, one to every shire-town in England, to go once a-week backward and forward, and to go through with the same horses they set forth with, and not travel above thirty miles a-day in the summer, and twenty-five in the winter, and to shift inns every journey, that so trade might be diffused—these would be sufficient to carry the sick and the lame, that they pretend can not travel on horseback; and, being thus regulated, they would do little or no harm; especially if all be suppressed within fifty miles of London, where they are no way necessary, and yet so highly destructive."

We have thought fit to introduce these extracts here, not so much for the purpose of amusing our readers with their absurdity, as to afford a caution to the general opponents of improvement. Arguments of a similar illogical nature are now used in reference to almost every proposed melioration in our social condition, and will doubtless, in a century hence, be quoted for their shortsighted folly, though at present meeting with countenance from a large class in the community.—(To be continued.)

The iniquitous "small boy," always ubiquitous in the Empire City, has shown much ingenuity by "improving the time" of the popularity of the uniform 5 cent fares, on the Manhattan elevated railways, to earn an "honest living." Under the pressure of circumstances, the intelligent gamin has learned that many tired men and women are willing to "go" the same old dime for a comfortable ride, paying five cents to Messrs. Gould, Field and Sage for transportation and five for a reserved seat to any person who, having pre-empted a place to sit down, desires to release it at a profit. Acting upon this discovery, the "small boy" hastens into the car and proceeds to exercise the American privilege of squatter sovereignty over as many seats as his diminutive frame can control. When half way up town, or down town, business begins. Passengers are packed in the car "like herrings in a box." A still, small voice comes from the right, low down: "U'm tired an' got a long ways to ride, but anybody's got fi' cents kin have my seat. Ain't goin' t' ast nobody fur 't, but here 't is fur fi' cents." And that plaintive tone, like the legendary pole, seldom fails of fetching the "persimmon."



THE STREET RAILWAY GAZETTE

JANUARY, 1887.—MONTHLY, \$2.00 PER YEAR.

COPYRIGHTED JANUARY, 1887.

PUBLISHERS:

THE WRIGHT-MONROE COMPANY.

Augustine W. Wright, President.
E. V. Cavell, Secretary.
S. L. K. Monroe, Treasurer.

GENERAL OFFICES:

CHICAGO, NEW YORK, BOSTON.

CHICAGO:

9 LAKESIDE BUILDING.

P. G. Monroe, General Manager.
G. G. Minor, Editors.
William Hughes, Editors.

NEW YORK:

181 BROADWAY.

Henry C. Lockwood, Resident Editor and Manager.

BOSTON:

198 WASHINGTON STREET.

T. P. Pemberton, Resident Editor and Manager.

BRANCH OFFICES.

ATLANTA, Ga., Chamber of Commerce Bldg., Wm. Minnigerode, Manager.

SAN FRANCISCO, Cal., 1322 Pine St., G. W. Fairchild, Manager.

A HAPPY NEW YEAR to the Brooklyn street railway companies that have secured guaranties that there shall be no "tie-ups" during 1887—to Presidents Yerkes and Cregier, who steered clear of the breakers which threatened to rise on their various lines—to those of the Boston companies whose vouchers have been found genuine—to the Gloucester Street Ry. Co. whose trouble with the city government has been adjusted—to the "Napoleon of the cable system"—to the Manhattan Railway Co., whose uniform fare of five cents has popularized the "L" roads—to the American Street Railway Association, the "cut" of whose Secretary adorns our portrait page—and to the International Street Railway Association, who promise to publish comprehensive statistics, relating to street railways, during this year. A happy and prosperous '87 to the promoters, managers, and all workers in the great and widening field of intermural transit, wherever dispersed, is the hearty wish of the STREET RAILWAY GAZETTE.

THE sixth annual ball of the street railway conductors and drivers of the West Division Railway Company was recently held at Uhlich's hall, and was a great success—in more senses than one—and cannot but greatly strengthen the bond of union between this prosperous company and its employes. The hall and adjoining rooms were densely crowded, the number attending not being less than 1,000. The dancing continued to an early hour, being interrupted only by supper and a speech by Superintendent Cregier. Mr. Cregier, on being introduced by Fred Wilson, Chairman of the Committee of Arrangements, was received with cheers. He said he had not come to make a speech, but he had felt much honored in receiving an invitation. He congratulated the members on the success of their entertainments, and if there was anything he could do hereafter, to aid in their success, he would be only too happy to do it. He desired the association to grow as the great city wherein it was located increased in greatness. None did more for that city than the drivers and conductors who took its workers to and from their daily toil. Their patience was sorely tried at times, he knew. Some of the men and women who traveled with them were not the most amiable in the world. When Mr. Cregier had completed his remarks, Mr. Wilson proposed three cheers for their Superintendent, "that we will stand by him, come what may, as he has stood by us." The cheers were given with a will.

Laws, though not dead, are sometimes allowed to slumber in non-observance; and when they are again enforced they seem strange, and people wonder why such laws exist. The Sunday law of Massachusetts has been applied to defeat a suitor who claimed damages for injuries received while acting as conductor on a street car on Sunday; he was non-suited because the court found that, at the time, he was unlawfully running a street car on the Sabbath; and on the 1st of last month (December) the Supreme Court decided against the companies, when the case of Nellie W. Day vs. the Highland Street Railway Company, came up on exceptions. This case came before the Supreme Court on May 7, 1883, from the Superior Court, and the decision was that street cars were run on Sunday in violation of the General Statutes, chapter 84, sections 1 and 2. Judge Colburn, in presenting the court's view, said: "We are of opinion that the whole evidence in the case shows that this car was being run for substantially the same purposes and from the same motives that street cars usually run on secular days—for the purpose of accommodating the public generally, and earning money from any one who might see fit to travel upon it. And we are of opinion that a car so run is run in violation of the law, though some of its passengers may be lawfully traveling. It is not within our province to determine the wisdom or expediency of the law, or how far there has been a change in public sentiment in relation to the proper manner of observing the Lord's day. These considerations are for the legislature. We can only take the law as it is written, and apply it according to its obvious meaning and the intention of the legislature."

GONE to the Courts, where it may remain for years, is the doom of a curious dispute between the City Council of New Orleans and the Carrollton Railroad Company. And the Daily Picayune laments that, as usual in any public improvement in this city there is opposition to the paving of Baronne street with asphalt. The property holders are desirous of having the work done, and the municipal authorities are prepared to authorize it. But it seems that there is a dispute about the grade. The street as at present constructed has a high arch, in the center of which are the two tracks of the Carrollton Railroad. The slope from the crown to the gutter is too great for a smooth pavement. In other words the asphalt pavement would have to be lower in the center than the present grade, or higher on either side where it meets the curbing of the side-walk. The City Surveyor claims that the grade of the tracks should be lowered; the railroad company refuses to lower its tracks, and thus the matter stands. The right of the city to enforce a change of grade of the track is before the United States courts, and may not be decided for some years. Either then this desirable work is to be held in abeyance for an indefinite period, or perhaps abandoned altogether, or the street grade must be brought up to that of the track. We seriously doubt the correctness of the position taken by the City Surveyor. Engineers who have been consulted by us contend that the grade of Baronne street should be raised instead of lowered. At present there is no slope from either Carondelet or Baronne street blocks to the cross-drainage gutters. The water backs up from the gutters of the cross-streets, and if a new flat asphalt pavement were laid on Baronne street at the present side-walk grade it would be a lake during every heavy rain storm. If on the other hand the pavement be raised to the grade of the present railway tracks there would be good drainage. Let the City Surveyor, therefore, again examine this question thoroughly, and he may find good ground for reversing his former opinion and open the way for the prosecution of this work.

It would be somewhat curious if, after the talk about electricity on the elevated railways, it should be practically adopted first for the surface roads traversing the same routes. This is one of the possibilities of the future, and is talked of more seriously, perhaps, now than ever \* \* \*. Local transportation facilities must be increased, if possible, for they are not yet equal to the demand, and perhaps never will be.—The Electrician and Electrical Engineer.

"LIFE'S romantic side" has been demonstrated at Louisville, Ky., in the discovery of a street car driver dying in hospital, and rescued by his faithful sweetheart. Some months ago, a young man named William L. Halbert removed to Louisville, from Evansville, and found employment on the Walnut-street car line. While unhitching his team, one of the mules kicked him severely in the face and side. Halbert paid no attention to his injuries, which he thought to be of little consequence, and went on with his work for several days afterward. He complained of a pain in the side and a dizziness in his head, and so much worse did his condition become that he was compelled to take to his bed. He was without friends and money, and was taken to the city hospital. For two months he was lying in a cot in the male surgical ward, during all of which time he was conscious only of his name and residence. He could tell nothing of how he came by his injuries, or who and where were his friends. But one dull November morning Miss Dora Matling was a passenger up on a steamboat from Evansville. Upon arriving in Louisville she at first communicated with the chief of police and told him she was looking for William Halbert, whom she had last heard from in that city. She visited the coroner's office, examined the records, and those in the health office. She was unable to find the name of Halbert, and at last she went out to the city hospital. Thinking the young man might have changed his name, Miss Matling, accompanied by the clerk, walked through the wards and closely scrutinized each patient. When she saw Halbert on his cot she ran to the bedside and threw herself upon him. She spoke to him with the most endearing words, but could elicit from him in reply nothing but a vacant stare. After the patient's condition was explained to her by the nurse of the ward, Miss Matling said that she and Halbert were engaged to be married. He came to Louisville in search of employment, and wrote to her every other day. The wedding was to have occurred October 12, but before that time Halbert's letters to her ceased. She grew seriously alarmed at his silence and came to Louisville to search for him. Miss Matling took Halbert out of the hospital, ordered a carriage, and had him conveyed to the Henderson wharfboat, where he was put on a steamer, and the young couple left for home. The young woman is the daughter of a wealthy farmer living about twenty miles from Evansville.

THE New Orleans city council have reached an unpleasant middle in connection with the Canal and Claiborne Street Railway Co.'s franchise. In another column is mentioned the company's protest against the setting aside of the official valuation of their property, as published in a previous issue of the STREET RAILWAY GAZETTE, which "emphasizes the bungling manner in which the whole matter has been handled by the authorities," says the *Daily Picayune*. "When the specifications were first drawn up, months ago, the *Picayune* called attention to the fact that no clause was inserted to protect the interests of the city in relation to the obligation to purchase the railway property at the end of the term of the original franchise." Our contemporary complains that "no heed was paid to the warning. Instead of advertising the franchise so as to bind the bidder to take the railway property at its appraised valuation, an appraiser was appointed to value their assets. The company now claims that the enormous valuation put upon its rails, rolling stock and equipments, months in advance of the time when the obligation of the city accrued, is binding upon the city, and threatens litigation. While it is very true the city has not lost her rights in the premises by this hasty and inconsiderate action, yet it may have the effect of intimidating bidders and depreciating the franchise which was to be sold. The public, however, will insist that every dollar the franchise is worth shall be realized, and hold those accountable who are responsible for the sacrifice, if there is any such slaughter as in the case of the Orleans Railroad franchise recently given away for a song." THE STREET RAILWAY GAZETTE ventures to reply that the Canal and Claiborne Street Railway Company will fight for their rights.

THE new street railway cable at Brooklyn, described in our Pointers, is simply an application of the rag-wheel and chain principle, and many engineers are of the opinion that it is destined to become a strong rival to the regular grip in the operation of cable roads. That the Atlantic Avenue Railroad Company has confidence in the cable system is shown by the fact that it has recently put up an immense brick building, capable of storing a hundred cars, in Park avenue, between Grand avenue and Ryerson street. Thus President Richardson is carrying out the recommendation he and President Tom L. Johnson (Indianapolis) officially reported to the Chicago (1883) Convention of the American Street-Railway Association, stating that "the only practical means as yet presented to our view for dispensing with animal power is the cable system."

Most of the larger street railway companies hitherto using quadruped force are anxious to secure a satisfactory substitute. And those who still consider electric railways as only in the experimental stage, are inclined to adopt the cable system. The "signs of the times" warrant the expectation that great changes may take place in the street railways of America before the expiration of 1887.

### The B. C. Pole Street Car Motor.

This is the title of a new street car motor, manufactured in Philadelphia, which is said to have no formidable complications in its construction, and yet produces very important results. It is to be put in operation on the streets of the Quaker City shortly. The motor can be supplied with motive power from electricity, gas engine, compressed air or steam, the great feature of the motor being the system of traction, which is adopted to operate the motor on the surface of the ground. The automatic foot action in this motor is a perfect step action, made so that there is a perfect rise and fall accurately placed on the ground, there held down, and the motor forced forward. This action is entirely different from the indefinite swing of a prop or strut to push forward a vehicle; for, if the said prop or strut should not catch or hold against anything, it would simply beat air; in this foot action the step is that of the front legs of the horse. In connection with the motor, an apparatus is attached underneath the passenger car called the "Differential Car Starter." This is also of peculiar construction, being a wheel within a wheel. There are no springs or cog-wheels in it. The back axle of the car rests upon two small wheels, these wheels run upon and in the flanges of two larger wheels, and are elevated four inches above the pavement, out of the way of sand. The draft is applied to two small friction wheels, which bear upon the large wheels near their top periphery, and thus is obtained a twenty-eight inch leverage acting directly upon the small wheels upon which the axle of the car rests. This leverage comes into action whenever there is any resistance, such as starting a car loaded with passengers, going up grade, or running over a stone or other obstruction.

A NEW CAR HEATER.—A new warmer, for street cars and other vehicles, has been devised, which would seem to be simple, economical and unobjectionable. It consists of fixing a tank under the car, filled with compressed gas and of sufficient capacity to carry a day's supply. To this tank is attached two half-inch pipes running in two corners of the car and up inside an iron tube six to eight inches in diameter, under the car seat, and in which a couple of Bunsen burners are fixed, and the product of combustion is carried off at the other end of the car. This is found to warm the car and to be easily regulated.

"Well, Newburgh's Street Railroad is open to the public." And the *Daily Journal* and the *Daily Register*, of Newburgh, N. Y., have vied with each other in proclaiming the "red letter occasion" of its "grand opening," Dec. 23. The *Journal* says that the inauguration of the Newburgh Street Railway marked a great day in the history of Newburgh—the Queen City of the Hudson; and its glowing illustrated report thereof extends over five columns, including a history of the enterprise.



## Do They Want "Boodle"?

THE Chicago West Division Elevated Railway Co. has inspired much newspaper comment since our last issue. "That elevated railroad" has been so captioned, and also as "an elevated railway on paper," "a big scheme," "business or buncombe?" etc. "An alleged incorporator" and others have been interviewed. And the occasion for kicking up such newspaper dust came about in this way: On Dec. 22, the promoters reported to the secretary of state, at Springfield, that the capital of the new company, viz.: \$10,000,000, had been subscribed, as follows: W. Weston, \$8,000,000; Edward D. Coles, S. N. Warren, Charles E. Warren and James R. Walter, each \$500,000. The election of the following as a board of directors for the first year was also certified to: Anson H. Lawrence, Edward S. Dreyer and Jacob F. Rehm. A certificate of final incorporation was accordingly issued by the secretary of state. Thereupon our newspaper contemporaries rushed for "boodle," it seems, and finding none, they became desperate. A representative of one of the evening papers ran after Mr. E. S. Dreyer, a well-known banker and real-estate man, who pretended to know nothing about the matter. "I do not know anything about the scheme," said Mr. Dreyer, when shown the dispatch concerning the incorporation by a *Journal* reporter, "and can not tell how my name is used in connection with it. I have not subscribed one cent toward the enterprise, and have never spoken to anybody on the subject or even heard of it till this minute, nor do I know one of the other parties whose names are mentioned in connection with it except Jacob F. Rehm, who used to be a clerk in this office." And forthwith the *Journal* placed its extinguisher on the project, saying, "another elevated street railway company for Chicago has been incorporated. There are now a dozen or so of these mid-air schemes, but it is still a question whether Chicago wants any elevated railroads over any of its streets."

The *Daily News* failed to get any nearer the treasury of the new company, and declared, Dec. 23, that the director, Jacob F. Rehm, "is not the original Jake, but his son, a young man engaged in the real-estate business on Clark street. The elder Rehm was a stockholder in the north side railway until he and Volney Turner sold out to the backers of Mr. Yerkes, and it is current rumor that the same Philadelphia and New York capitalists who placed Mr. Yerkes at the head of the north side company have subscribed for the stock of this new enterprise." The interviewer "howled" in vain at this director, and Mr. Rehm only said, "all I know about the company is that a friend of mine came to me, through another friend, and asked me to subscribe for stock. I did so, and last week was notified that I had been elected a director. The men who are behind this have plenty of money—I don't know anyone who can beat them for that—and they intend to see the scheme through. I know only one of them personally. I can't tell you who they are, because if I did it would make more talk than that sale of the north side road."

Mr. E. S. Dreyer, whose answer to the *Journal* is given above, told the *News* a very different tale: "We have plenty of money," he said, "and we expect to start building next spring. We have not yet picked out the streets on which we shall ask to be allowed to run. We will do that later. I don't think we will have any trouble at all in getting the right of way. Already letters have come in from parties owning property on the west side offering their assistance. Two very wealthy gentlemen who own large tracts of land west of Western avenue, called on me this morning and made a voluntary offer of money, without consideration, to help us to get what we want. No, I won't tell you how much they offered, but it was a good many thousands. You see, all those prairies would be settled up in almost less than no time if an elevated road was started. Then all the land between the limits and Oak Park would be subdivided and sold. The value of property will increase 100 per cent. Of course the greatest opposition to the road will come from down-town business men, who always object to anything of the kind, and perhaps they may be able to interfere with us."

The other director, Attorney Anson H. Lawrence, was also promptly interviewed. He simply said that the stockholders of the Chicago West Division Elevated Railway Co. "are eastern gentlemen representing New York and Philadelphia capital. Some of them have been here and looked over the territory, but of course the feasibility of the project is yet largely to be determined. I know enough about them to say that the steps thus far have been taken, not for any buncombe, but with the intention of building the railroads. The great West Division contains the mass of people of the city. Unlike the south side it has no extensive system of suburban trains to help them out. They are the people who depend on public transportation almost entirely, and the elevated line of these gentlemen will meet their demands."

The *Tribune* is in harmony with its neighbors in barking at this promising scheme, which has boldly come forth without any "boodle," and our esteemed contemporary says, "It will be seen that as yet this is a mere paper road, like all its predecessors. When the projectors set to work to try to get the right of way on any particular street they will see where the shoe pinches."

## The Sprague Electric Railway Tests.

On Tuesday night, the 28th ult., was concluded the experiments which the Sprague Electric Railway and Motor Company have been carrying on, on the 34th Street Branch of the Elevated Railroad, preparatory to undertaking experiments on a much larger scale. Among those present were Mr. E. H. Johnson, President of the Edison Company; Chief Engineer Sloan of the Elevated Railroad; J. D. Campbell, Foreman of the Elevated Railroad Shops; H. A. Webster, Master Car-Builder; J. O. Morrow, Superintendent of the Sea View Railroad Company; Charles H. Foster of Drexel, Morgan & Co., and Col. Henry C. Lockwood, Resident Manager of the STREET RAILWAY GAZETTE at New York.

Before beginning the run, Mr. Sprague explained that in the early part of the experiments the car would be run over the road, making ordinary trips; then a variety of experiments would be performed, and, finally, the machines would be put to some very severe and exceptionable strains. The experiments were made on the sidings and on the north track. The stations at the ferry end of the line and at Second and Third Avenues were brilliantly illuminated with a large number of Edison lamps, the current for which was supplied from the same source as supplied power for operating the car, the station being located in Durant's old sugar refinery in East 24th Street. Connection was then made with the track, and immediately Car No. 293, which was standing in a pocket, became brilliantly lighted. The switches being thrown over, the car was rapidly run out to the main track. The first trips were uneventful. The car was smoothly and easily run between the Ferry and Third Avenue, sometimes stopping at the Second Avenue Station. At this latter point there is a ninety-five foot grade, which is the maximum grade that occurs at any station on the Elevated Railroad. After several trips had been made, Mr. Sprague began to show some of the exceptional possibilities of his method of handling a car, the first of these being the starting and stopping, without shock or jar, on the ninety-five foot grade at the Second Avenue Station, the car being controlled solely by the motors and without the use of any hand or shoe-brakes whatsoever. After some running of this character, the speed of the car was increased until, when it was running on the upper-grades, it was moving about ten miles an hour; and occasionally, when coming on the down-grade, Mr. Sprague would allow the car to run about eighteen or nineteen miles an hour.

The track on which the experiments were made presents difficulties, not only that the middle station is at a heavy grade, but that just above this station, between it and Third Avenue, there is a double curve on which the car leaves the straight track and runs into the Third Avenue Station. This curve is likewise on a grade. Notwithstanding this, the car ran smoothly and easily on every part of the trip, although not properly lined-up, and hence with a great deal of



friction on the side-bearings. On one trip, in coming down, Mr. Sprague stopped the car at the Second Avenue Station, and then allowed it to creep at variable speeds down to the lowest perceptible rate of motion—a movement so slow that it would have been quite feasible to have gotten off the car and cracked a nut under the wheels, removing it before the wheels passed over it.

Later in the evening the car was run rapidly past the Second Avenue Station on the down track, and between this station and the Ferry end was brought up to a speed of about twenty-one miles, and while on the maximum down-grade, the car was suddenly slowed down and brought to a sharp stop in a distance of about one hundred and twenty feet. In another experiment, the car was run rapidly up the grade, the current was shut off and the car allowed to run backwards, when it was immediately stopped and run forward again solely under the operation of the current.

Toward the close of the experiments, Mr. Sprague put the car to some very severe tests. Several times were taken from starting to stopping between the Ferry end and the Third Avenue Station, a distance of nearly a third of a mile, and taking in the ninety-five foot grade and the double curve. On the down grades, these times averaged a minute and fourteen seconds, and on the up-grades a minute and twenty-five seconds. The speed of the car was timed on the grade going up by counting the beats of the trucks on the rails, and it was found to be running at twelve miles an hour, which is the normal rate of speed on the Elevated Road on a like grade.

Just before the close of the experiments, some very sharp strains were put upon the motors. These consisted in braking the car to its full motor capacity, and was done in going down grade and at the Ferry end of the Station. With his regulating switch in one position, Mr. Sprague threw over the brake lever, and instantly the car was brought up sharply and suddenly, with such a rapid gradation that the wheels on the trucks "skidded" in rotation on the tracks, and the car stopped in a fraction of its own length. These experiments were repeatedly tried, Mr. Sprague feeling that, since this was the last of the present set of experiments, it mattered little if the machines were actually wrecked. He should at least, he said, find out what was in them. Similar experiments were tried in starting. The car, when standing at dead rest at the Ferry Station, had the current suddenly given to it. There was an instant continuous "skidding" of the wheels and the car actually jumped away from the station with such suddenness of acceleration as to nearly take a person off his feet.

The whole experiment proved conclusively the soundness of all the principles involved in Mr. Sprague's system, and was watched with great interest by the practical men who were present, and who are best capable of judging of work of this character. The electrical pressure used was about 600 volts. As Mr. Sprague explained, this was not the pressure that was necessary in order to handle a car, or train of cars, over this distance, but it is the electro-motive force which has ultimately to be used in handling trains on the Elevated Railroad system; and he holds that it is useless to experiment with lower electro-motive forces, when the difficulties of the high pressures have all got to be met and overcome before any extended application of electricity, to the Elevated Railroad system, can be made.

During the entire experiments no brakes of any kind except the motors were used, and the car invariably and always responded to every touch of the operator's hand, the same apparatus being used to control the speed and power of the car as was employed in controlling its braking capacity. Notwithstanding the viciousness of some of the experiments which were tried, and the sudden and great strains which were put upon the apparatus, there was not a hitch of any description, nor was there any investigation necessary of any part of the apparatus. The commutators of the machines at the close of the runs were bright and clear, the gears were in perfect condition, and the whole apparatus was in proper shape for another run; this notwithstanding the fact that there had been but one previous trip made in five weeks, and that the motors had been standing on the track all that time.

## Street Railway Patents.

The following list of recent Patents relating to Inter-mural traffic, is specially reported for THE STREET RAILWAY GAZETTE by Wm. G. Henderson, Solicitor of American and Foreign Patents, 925 F Street, Washington, D. C. A copy of any of the following will be furnished by him for 25 cents.

Issues of Nov. 30th, Dec. 7th, 14th, 21st, and 28th.

- 353,183 Cable railway—G. Warburton, Philadelphia Pa.
- 353,121. Marine railway—A. Catrari, Brooklyn, N. Y.
- 353,086. Elevated railway superstructure and car truck—E. S. Shaw, Cambridge, Mass.
- 353,028. Metal railway tie—E. N. Higley, Somersworth.
- 352,970. Railway turn table—J. F. Class, Pleasant Hill, O.
- 353,500. Concrete molds for subways for cable roads, ditches, etc.—E. L. Ransome, San Francisco, Cal.
- 353,361. Cable car grip—T. Kerr, New York, N. Y.
- 353,632. Car starter and brake—E. Hartmann, Philadelphia.
- 353,284. Sign and advertising board for street cars—G. M. Brill and J. Rawle, Philadelphia, Pa.
- 353,313. Cable railway—H. M. Lane, Cincinnati, Ohio.
- 353,321. Cable railway—T. J. Lovegrove, Philadelphia, Pa.
- 353,391. Wagon railway—T. Whalen, Rochester, N. Y.
- 353,809. Roller cable grip—G. A. Polhemus, Nyack, N. Y.
- 353,941. Cable gripping device—J. Hellings, Philadelphia.
- 353,759. Car starter—B. C. Pole, Camden, N. J.
- 353,878. Street car—W. H. Nelson, Alexandria, Va.
- Street railway car—J. C. Brown, San Francisco, Cal.
- 353,754. Railway appliance—J. E. Nathan, New York, N. Y.
- 353,713. Grip for cable railways—C. Scholz, Chicago, Ill.
- 354,479. Grip for traction cars—J. S. Lake, Pleasantville.
- 354,141. Cable railway—J. P. Hunt, Philadelphia, Pa.
- 354,401. Railway brake—E. D. Eames, Watertown, N. Y.
- Railway tie—F. G. Johnson, New York, N. Y.
- 354,433. Railway tie—R. Morrel, Summit, N. J.
- 354,350. Conduit for cable or electrical railways—E. Sam-uel, Philadelphia, Pa.
- 354,295. Switch for cable railways—S. A. Witherspoon, St. Louis, Mo.
- 254,250. Metallic cross tie for railways—R. S. Sea, Salvisa.
- 354,348. Water tight bulk-head for underground railways—J. E. Robinson, Baltimore, Md.
- 354,812. Car heater—R. Johnson and J. F. Buerkel, Boston, Mass.
- 354,873. Railway cable grip—C. T. Ryland, Jr., San Jose.
- 354,531. Cable railway construction—Z. P. Boyer, Philadelphia, Pa.
- 354,558. Elevated railway—H. I. Latimer, Cranford, N. J.

## PERSONALS.

MR. DANIEL D. CONOVER, of New York, has recently retired from the presidency of the Forty-second st., Manhattanville and St. Nicholas ave. Railroad.

MR. MELVILLE C. SMITH, of New York, is the promoter and general manager of the Arcade, as it is commonly called for short. His office is in the Boreel Building and is the scene of perpetual activity. Levi P. Morton, Russell Sage, Cornelius N. Bliss, John J. Davenport, Mayor Wickham, and prominent bankers and brokers may often be seen there. Mr. Smith has been "talking, eating, drinking and sleeping on Arcade for twenty years."

COL. ROWLAND R. HAZARD, is the most redoubtable opponent to the Arcade system of New York. His "perflax" scheme for shooting under Broadway has come into notice within a year. The Colonel is a slender wiry man, who wears eye-glasses and talks "perflax" under heavy pressure.

MR. O. B. POTTER, of New York, opposed the Arcade and has a plan of his own for widening Elm St., and running a road up that street through Lafayette place, and Fourth Avenue to the Grand Central Station. There are rumors connecting him with the revival of the Central Underground Railroad scheme.

MR. F. H. HAIN, general manager of the Manhattan Elevated Railway, has been offered, it is said, a similar position on the Philadelphia and Reading road.

## POINTERS.

## ALABAMA.

*Birmingham.* A company has been organized by A. B. Johnson and others to build a street railroad to Woodlawn.

The North Birmingham Street Railroad Co. has been incorporated by John W. Johnston, Charles E. Whitlock, H. B. Johnson, E. M. Entwiler, and John B. Brodie, to connect the city with the property of the North Birmingham Land Co. Capital stock, \$100,000.

*Florence.* The Florence Street Railroad Co. has been incorporated by W. B. Wood, Lee Howell, C. G. Smith, and others. Capital stock, \$50,000.

*Huntsville.* The North Alabama Improvement Co., of Huntsville, and Rushton, Reynolds & Co., Birmingham, applied for the franchise for a street railroad. The franchise was granted to the Improvement Co., and one mile of track will be built by May.

*Montgomery.* The electric cars were taken off the Court Street line during December, and two mule cars have been running instead. The company found it necessary to take the electric cars off until the new building is finished, and the new machinery is put up and in place. The work has been pushed on as rapidly as possible, and the electric system will be in full operation very shortly. "In Montgomery the electric street railway is a practical success."

*Selma.* Surveys are being made for the projected electric street railroad, "pointered" in our last issue.

*Sheffield.* The Tusculumbia & Sheffield Street Railroad Co. has been granted the privilege to lay tracks. All the stock has been taken.

## CALIFORNIA.

*Los Angeles.* A franchise was obtained, Dec. 9th, for a new cable road to run across Buena Vista-street bridge to East Los Angeles. The work of construction has been commenced.

*San Francisco.* Mayor Bartlett has vetoed orders 1889 and 1890, granting franchises to the Omnibus Railroad and Cable Company and to A. W. Rose Jr. to run railroads along certain streets.

The serious strike disturbances which have unfortunately occurred here are referred to in another column.

## COLORADO.

*Denver.* The Denver Street Railroad Construction Co. has received from the Brush Electric Co. a primary generating machine of 100 H. P., and five electric motors of 12 H. P. each; the system of conductors is on the plan invented by Professor Short.

## CONNECTICUT.

*New Britain.* The street railroad was opened November 30th with considerable ceremony. The citizens are highly pleased with the accommodation.

## DISTRICT OF COLUMBIA.

*Washington.* Two bills have been introduced in Congress for street railroads with electricity or cables as the motive power; the Capitol, North and South Washington Railroad Company, and the Washington and Georgetown Street Railroad Company, the latter will build a cable line.

## FLORIDA.

*Gainesville.* The Gainesville City and Suburban Railroad Company has been organized. President, W. H. Robertson; General Manager, R. L. Robb. Eight miles of road will be built at once.

*Pensacola.* The Pensacola Street Railroad has been purchased by J. F. Shaughnessy, of New York City. The line will be extended and improved, and it is proposed to operate the line by electricity. The *Picayune* says: "The recent sale of this property has placed it in the hands of men who will utilize all of its unimproved franchises, the first move contemplated in this connection being the laying of the track on Government street as far east as the bay shore and west to the corporation limits. Such other thoroughfares, the travel on which will warrant the expenditure, will be included in the extension. Mr. S. F. Chipley, a gentleman of superior executive ability, has been designated the manager of the whole system."

## GEORGIA.

*Atlanta.* The West End and East End Street Railroad Co. is to be incorporated,

*Savannah.* The Savannah Street Railroad Co. is to be incorporated; John H. Estill, Frank D. Bloodworth and T. W. Dasher, are interested.

A new street railroad is to be built from the Ocean Steamship Co.'s wharf to the Savannah, Florida and Western R. R. Co.'s wharf. The cars will be built by the Pullman Car Co.

*Thomasville.* The Thomasville Street Railroad Co. is to be incorporated.

## ILLINOIS.

*Chicago.* There have been three projects on foot to furnish Dearborn Street with street railway tracks; one is by President Holmes, of the Chicago City Railway Co., another is by President Yerkes, of the North Chicago City Railway Co., and the third was advocated by the Dearborn Street Union Railway Company, the organization gotten up by the property owners who proposed to construct a railway and lease it to the old companies. This latter "company" may never be heard of again. Commissioners were selected to incorporate the company, Mr. Lazarus Silverman prepared the application, and the necessary permission was obtained. It was discovered, however, that the document called for the construction of railways in all parts of the city. This was more than the property-owners contemplated when they signed the agreement for the right of way, and some who didn't want to go into the scheme got up another application, limiting the company to Dearborn street. The new application was handed to Mr. Silverman, with a request that he send it to Springfield with the old permit, which was canceled. He never did so, and hence the company was not organized. A petition is now in circulation with the view of turning over the street to the North Side company, which has promised to construct a bridge over the river. Joel Bigelow is pushing this scheme.

The City Passenger Railway Co. are running two sets of cars on the Adams street line, as stated in these columns last month. But they have abandoned the "loop" arrangement of running, as it caused considerable confusion. And they now run each set of cars back and forward on the same route. Twenty new cars have been added on the new Center avenue line. One-half the cars are yellow with blue lights, and run east on Harrison street to Franklin, thence north to Washington, and east to Michigan avenue, and return by the same route. The other half are white with colorless lights, and go by way of the Adams street route, returning the same way without using the loop. The Adams and Washington street cars run as they did before the loop system was inaugurated. Night cars are discontinued.

The Chicago West Division Railroad Co. propose to build a line on Ashland avenue, commencing at Clybourn avenue bridge and running south to Twenty-second street, there connecting with the Blue Island avenue line. Wood street will be used part of the way.

The City Council has passed the ordinance giving a twenty-years franchise to the North Chicago Street Railway Company to lay tracks on Division street from Clybourn avenue to Milwaukee avenue. The cars must be operated by animal power only, and the line must be in operation by July, 1887. The company is required to bear half the expense of building bridges and operating and maintaining them. A license of \$50 a car is provided for.

The Chicago City Railway Co. have supplied from two to three hundred of their cars with heating apparatus, with which the street car riders of the South Side are delighted.

*Cicero.* A condition of the ordinance granted the People's Horse-car Company for a track on Lake street from Fortieth street to Austin, on the 19th of June last, was that the road should be built and in running order by December 31, past. Mr. George E. Plumbe, on behalf of the company, petitions for an extension of time to July 1, next, offering to reimburse the town for the cost of improving that part of Lake street which the company had agreed to.

*Hyde Park.* At the board meeting of the village trustees, Dec. 13, a communication was received from the Sec-



retary of the South Park Board explaining that the board objected to the cable road on Fifty-seventh street because that is one of the principal entrances to the park. President Holmes presented a plot showing a new proposed route for the cable line to run from Lake avenue to Jefferson avenue across the block at a point about 300 feet north of Fifty-seventh street, about opposite the South Park Station on the Illinois Central. The citizens do not object to this, and the matter was referred to the Judiciary Committee and Attorney to report and prepare an ordinance.

On Dec. 20, Attorney Freeman presented an ordinance granting the Chicago City Railway Company the right to lay down and operate a cable "loop" line. The route begins at the corner of Fifty-fifth street and Jefferson avenue; thence to a point 287 feet north of Fifty-seventh street; thence to Lake avenue, to Fifty-fifth street, and to the place of beginning. Owing to objections by some of the property-owners along the line the ordinance was laid over.

*Lake.* An ordinance was presented, Dec. 22, to the Board of Trustees of Lake, allowing the Chicago City Railway Company to construct double tracks, with side tracks and switches, on Forty-seventh street from Halsted to State street, and on State street from Sixty-third to Vincennes avenue, and on Vincennes avenue to Eighty-first street; on Sixty-ninth street from State to Halsted; on Halsted from Sixty-third to Sixty-ninth; across the Sixty-first street viaduct from State street to Wentworth avenue, and on Ashland avenue from Thirteenth to Fifty-fifth street. The matter was referred.

#### INDIANA.

*New Albany.* The New Albany Cable Railway Co., of which Dr. Brockington is President and Fred Dieffenbach, Secretary, petitioned for a right of way on Market, Vincennes, West Ninth and Elen streets, and Ekin avenue. An ordinance embodying the above was presented and was referred to a committee of six members to report at the next regular meeting of the Council. A meeting of citizens opposed thereto was held Dec. 15, when addresses were made against the asked-for grant. Father John Kelley, the rector of Holy Trinity, is one of the most active in opposition to the grant, and has been industrious in procuring signatures to the remonstrance. The committee of the City Council held a meeting subsequently, but nothing definite was done in the matter. The majority of the committee were disposed to report favorably, but one member thought that the company, in case the ordinance was passed, should be required to file a bond in a sum of not less than \$50,000 to have the road completed within a certain specified time.

#### IOWA.

*Clinton and Lyons.* The City Councils of the two cities have granted J. W. Hartzell, of Moline, the right to construct eight or ten miles of street-car line in the two cities. Work will commence March 1.

*Des Moines.* The Des Moines Broad Gauge Street Railway Co. has a line  $4\frac{1}{2}$  miles long from the Court House to the State Fair grounds, over which they carried, with six cars, 25,000 passengers, to the fair grounds, during the fair week last September. The company have also constructed a line on Fourth Street North,  $2\frac{1}{2}$  miles long, making a total of seven miles since the company was incorporated five months ago. Their cars are roomy, and heated with stoves, and travel is rapidly increasing; and this company is coming boldly to the front. They have built a two-story barn 132x 50 feet (to accommodate 80 horses), of brick, in the most substantial and approved style. Their rails are of steel, 52 lbs. to the yard. And "the Broad Gauge has the best equipment in the State of Iowa."

#### KANSAS.

*Cottonwood Falls.* The Consolidated Street Railway Co. of Cottonwood Falls, has been incorporated. Capital stock \$10,000. E. A. Hildebrand, C. J. Lantry, W. Adare, Strong City; J. M. Tuttle, J. W. McWilliams, W. H. Holsinger and W. P. Martin, Cottonwood Falls, incorporators.

#### KENTUCKY.

*Louisville.* One of the cars of the Market and 18th Street line was run into by a coal cart, December 10th. As soon as the coal-cart driver saw the damage he had done he

jumped from his seat and ran down Preston street. Several drivers of cars, already become blockaded, pursued him several squares, and finally captured him. He was brought back to Market street and given in charge, and prosecuted.

*Owensboro.* The Owensboro City Railroad Company (composed of the city's own capitalists, including Attorney J. D. Powers, J. M. Fuqua, J. M. Alsop, etc.) have outstripped the Nashville speculators who sought right of way in Owensboro, and "home talent" keeps up the entertainment. About a mile and a half of the road is now finished, constructed of 20 lbs. T rail,  $4' 8\frac{1}{2}''$  gauge. The rails, fish bars, bolts, etc., have been supplied by the New Albany Rail Mill Co. It is proposed to have  $3\frac{1}{2}$  miles constructed by the 1st of July next.

#### LOUISIANA.

*New Orleans.* The franchise of the Canal and Claiborne Street Railroad was offered at public auction again last month. Mr. Joseph Hernandez bid \$25,000; Judge Ogden made an informal proposition to give \$26,000, or  $\frac{1}{2}\%$  of a cent to the city per passenger, at the option of the authorities. A protest was made against the sale by T. Wharton Collins, who claimed the franchise on the plea of having offered the highest bid at the September letting. President E. J. Hart also protested; the company holding the city its debtor; the appraisement already made being considered valid and final; that the contract is clear and free from ambiguity, etc. That the appraisement was made and agreed to; that the appraisers filed their report, and that it is *per se* binding and final, neither requiring the approval or disapproval of the parties. The city and the company are therefore claimed to be estopped and can make no objections; the report having force and effect of *res adjudicata*; therefore the Canal and Claiborne Street Railroad Company hold the city bound by it.

The Commissioner of Public Works has notified the President of the St. Charles Street Railroad Company to commence the planking of Triton Walk. In response to a communication from the attorney of the company asking for further delay, the commissioner states that he gave notice to the company as far back as July, 1885.

The New Orleans City Railroad Company has been requested to clean out the bridge corner of Decatur and St. Peter streets.

#### MARYLAND.

*Baltimore.* Mr. O. L. Richardson, the engineer in charge of the Daft Electric Street Railroad, reports that the road is in satisfactory operation; the motors run 192 miles per day, and there is no hitch in the arrangements.

#### MASSACHUSETTS.

*Arlington.* There has been no little agitation and display of interest here in reference to the horse railroad question. Says a local paper: The Cambridge Company wanted to get possession of the Arlington road—or to build the track from the Center to the Heights—themselves. The gentleman, whose name appeared in a warrant, asking to have the track removed, was not an abutter, and at a hearing before the selectmen on the removal, there was not an abutter present. President Cummings remarked at that hearing that if the track belonged to the Cambridge Company they would have removed it before then. As the selectmen have not ordered the track removed, but have signed the petition in the interest of the Cambridge Company, the president and selectmen are both in an awkward position. The Arlington Street R. R. Company is willing to extend the track to the upper part of the town, and desires to do what will be for the best good to the greatest number. Where there is one person who wants the track removed, there are 50 who would be glad to have it extended.

*Boston.* The plan for the consolidation of the Metropolitan and South Boston Horse Railroad Companies has been under consideration for a long time. Action on the matter was delayed by the defalcation of Reed; but it has now been taken up again. The proposition comes from the Metropolitan road, and is about as follows: The South Boston Horse Railroad stockholders are to receive share for share—that is, they exchange their certificates in the South

Boston for an equal number of shares in the Metropolitan, which is paying 10 per cent. It is also probable that the South Boston road will pay its usual dividend in January. "Those who are most familiar with our system of horse railroads are of the opinion that the consolidation of these two roads is a good arrangement for all parties in interest," says the *Boston Post*.

The selectmen of Brookline gave a public hearing Dec. 14, on the petition of the Metropolitan Railroad Company, for authority to extend its tracks. President C. A. Richards presented a petition containing 693 names for the proposed new line for Brookline. He had also a second petition for extending the Longwood Avenue branch. The right is asked to operate the cars by cables or electricity, if the location is granted to the Metropolitan. Mr. Henry M. Whitney represented the West End Street Railway Company, and claimed the right of way in preference to the Metropolitan. The selectmen "took the matter under advisement."

Upon the motion of Alderman Hart, based on the report of the select committee appointed to consider the matter, the Boston Board of Aldermen passed an order, Dec. 27th, granting permission to the West End Street Railway Company to lay down tracks of the railway of the said proposed company, in the streets of the city of Boston, with the right to construct, use and maintain a double track and suitable curves, turnouts, switches and connections on certain streets. The right to lay down the tracks located by this order is upon condition that the whole work of laying the same, the form of rail to be used, and the kind and quality of material used in paving said tracks, shall be under the direction and to the satisfaction of the superintendent of streets, and shall be approved by him. Also upon condition that said directors of said West End Street Railway Company shall accept this order of location, and shall agree, in writing, to comply with the conditions herein contained, and shall file said acceptance and agreement with the city clerk within 30 days from the passage of this order; otherwise it shall be null and void.

President Richards of the Metropolitan railroad states that the expert accountant who has just gone through the stock ledger of that road found that every certificate ever issued by that company—40,000 shares in all—is properly accounted for, and all powers of attorney connected therewith were also found all right.

The annual meeting of the Cambridge Horse Railroad Company, which will occur on the afternoon of Jan. 10, promises to be an exceedingly interesting occasion. There are two factions among the stockholders, one of which, it is claimed, is anxious for a union with the Consolidated road, while the other desires to join the road with the Metropolitan. When the contest occurred which gave the control of the road to the present management the capital stock of the company aggregated 16,000 shares, and now there are 19,500 shares. Both sides claim to have a majority of this amount, either actually secured or so placed that it can be secured before the date of the meeting.

The Boston Consolidated Street Railway Company have declared a dividend of four per cent. payable Jan. 1, 1887.

The same company has just placed fourteen new cars on its roads. The cars were built by J. M. Jones' Sons, of West Troy, N. Y.

*Gloucester.* President Fitch, of the Gloucester Street Ry. Co., has succeeded in adjusting the obstructions threatened by the city officials "by concessions on the part of the city." They hope to work more harmoniously with the new City Council just elected, etc. The Company operates four miles of track, have eleven cars, and ninety horses, and "are doing a fine business." Before the close of their annual dinner last month, at the Quincy House, Boston, the company's stock advanced 100 per cent.

*Haverhill.* The railroad commissioners have given it as their decision that the requisites of public convenience and necessity require the construction of the Haverhill & Lawrence railroad.

*Lawrence.* The Merrimac Valley Horse Railroad Co. has been refused permission by the city to lay tracks on certain streets as petitioned for.

*Lowell.* The Lowell & Dracut Street Railroad Co. has been granted permission to lay tracks.

*Pittsfield.* The selectmen, in company with Lawyer Pingree, went over the route of the proposed new Dalton road Dec. 13. The matter comes up at the January meeting of the county commissioners.

*Springfield.* Mr. Olmsted, the president of the Springfield Street Railroad Co., proposes to adopt conductors for the cars next spring, and to employ them permanently. The matter of an extension to West Springfield has not been put before the stockholders, but will probably be built ultimately; it is intended to extend the line 100 or 150 feet to accommodate the Casino.

*Westfield.* A local subscription has been started to raise money for a street railroad. \$6,000 have been raised toward the necessary total of \$20,000. There will be a single track, and the fare will be 5 cents. Outside capitalists were negotiating to put in the line, but "the knowledge that out-of-town capitalists are ready and waiting to step in and give Westfield a street railway has aroused local pride to the pitch of starting a subscription paper." The proposed route is from the depot through Elm, Broad and Silver streets, Day avenue, Court and Elm streets, single track, with turnouts on Elm, Broad and Silver streets and Day avenue.

*Worcester.* The Worcester Electric Power Co. will operate the Worcester & Shrewsbury R. R. on the Daft system.

#### MICHIGAN.

*Detroit.* The electric railway operates satisfactorily, it is reported. The current is conveyed by a center rail to the motors which are suspended between the wheels of the cars. The station has a 100-horse power boiler, and a 10 by 12 automatic engine. Two cars are now run, and the estimated coal consumption is not over 1,000 pounds per 10 hours' work.

#### MISSOURI.

*Chillicothe.* A street railroad will be built shortly. Dr. R. Barney, D. Stewart, and others, are interested.

*Kansas City.* The city officials are fighting the cable railroad company over the ordinance requiring the company to station watchmen at the intersections with the mule lines. The company has filed a petition for a restraining order.

*St. Louis.* The engine house and car shed of the cable railroad were destroyed a few weeks ago by fire. The engine, which cost \$70,000, was badly damaged and 42 cars were burned.

The council committee on railroads has had several deliberations on the Central Electric Elevated Railroad ordinance, authorizing F. A. Mann, G. F. Branham and others to construct a road from Broadway to Berlin avenue and the King's Highway; also an ordinance for another, but similar road; it is claimed that as the cars would not exceed six feet in width they would cause little inconvenience in the 15-foot alleys.

A council bill has been introduced to authorize the St. Louis Bridge, Fair Grounds and Forest Park Elevated Railroad Co., to construct a line from Washington avenue at Third street to Lindell avenue and the King's Highway; cables, steam or electricity to be used; the franchise to run for 50 years and the company to pay the city \$1,000 per annum for the first five years, \$2,000 per annum for the next five, and \$5,000 per annum for the remaining years of the franchise.

The Iron Mountain Elevated Railroad bill has been dropped.

The St. Louis Railroad Co. has had the ordinance passed authorizing the use of any power but steam; electric storage batteries will be used on the cars.

#### NEBRASKA.

*Wymore.* The Wymore & Blue Springs Street Railroad Co. has been incorporated at Lincoln; the company may also run carriages and stages. Capital stock, \$50,000.

#### NEW JERSEY.

*Orange.* The Orange Cross Town & Orange Valley Street Railroad Co. has been authorized to erect poles and wires for experimenting with electric motors. The poles to



be 75 feet apart and to have not more than six wires strung upon them. A similar resolution was killed some time ago.

#### NEW MEXICO TERRITORY.

*Socorro.* The Committee on Public Grounds and Buildings of the City of Socorro advertise for bids for a street railway franchise. The line is to be about two miles long—more or less. It is for the bidders to state length of time for which they wish franchise to run, etc.

#### NEW YORK.

*Albany.* It is probable that the cable system will be adjusted before very long for the State street line. The company will increase its capital stock from \$275,000 to \$500,000 for this purpose. The cost for track, machinery, equipment, etc., complete, is \$325,000.

*Brooklyn.* The Union Elevated Railroad Co. will apply to the Department of City Works for a permit to open the streets and begin work, the Supreme Court having confirmed the report of the Commission, whose consent stands in place of the property owners. The rumors of the consolidation of this company with the Kings County Elevated Railroad Co. are entirely unfounded.

A tie-up took place on all the roads on December 22d, there was some rioting and smashing of cars, but the lines were kept in more or less operation by old non-union drivers and conductors and new men.

The following are interesting items, taken from the annual reports of the several roads, beside those comprised in our last issue:—Atlantic Avenue R. R.: Cost of road and equipment, \$31,691.68; total assets, \$34,024.40. Brooklyn Elevated R. R.: Cost of road and equipment, \$9,689,194.54; gross earnings from operation, \$518,480.54; operating expenses, \$379,372.36. Total length of track, including sidings and turnouts, 13.10 miles; passenger cars, 90; flat cars, 2; locomotives, 30; passengers carried, 10,158,665. Coney Island Elevated R. R.: Gross earnings, \$510; operating expenses, \$916. Total deficit, \$82,418. Grand Street, Prospect Park and Flatbush R. R.: Cost of road and equipment, \$714,530.76; gross earnings, \$123,580.26; operating expenses, \$104,950.52. Total length of single track 4.25 miles; closed cars, 35; open cars 40; passengers carried 2,562,687; employes, 110. Prospect Park and Coney Island R. R. (Operated by Atlantic Avenue R. R.): Cost of road and equipment, \$31,691.68; gross earnings, \$83,835.68; operating expenses, \$69,311.45; closed cars, 30; open cars 40; horses 219; passengers carried (nine months) 1,788,475. South Brooklyn Central R. R.: Cost of road and equipment, \$408,195.93; gross earnings, \$26,680.82; operating expenses, \$19,123.82; length of single track, 8½ miles; closed cars, 21; open cars 21; horses and mules, 193; employes, 70; passengers carried, 2,039,647. Van Brunt Street and Eric Basin R. R.: Cost of road and equipment, \$98,027.27; gross earnings, \$6,437.42; operating expenses, \$4,486.15.

A fifth cable line, that of the Atlantic Avenue Railroad Company in Park avenue, Brooklyn, is well under way and a portion of it, from Broadway to Washington avenue, may possibly be in operation this month. If it proves satisfactory the line will be extended to Fulton Ferry as soon as the frost is out of the ground next spring. The cable to be used on this road is different from that employed on the Bridge and the other lines. It consists of two spring steel ropes each three-quarters of an inch in diameter. These are placed parallel to each other at a distance of about five inches and are riveted by metallic lugs, thus forming, as it were, the links of a chain. The machinery attached to the bottoms of the car consists of a toothed wheel, with a lever apparatus and the ordinary brake, operated by a man on the front platform. The teeth of the wheel are long and narrow enough at the end to pass readily through the slot in the conduit, and being bent at a small angle catch the crossbars, or lugs, between the two ropes, thus communicating the momentum of the cable to the car and driving it forward.

*Coeymans.* A street railroad is projected from the village to the junction.

*Coney Island.* The Coney Island Elevated Railroad is to be extended from West Brighton Beach to the Marine Railroad at Manhattan Beach.

*New York.* The Daft Electric Motor Company have constructed a motor double the horse-power of the one experimented with last spring, on the Ninth avenue elevated road. In view of further trials some changes have been made in the circuit, that conveys the current to the motor; and Mr. Daft has transferred the rail to the outer side of the track, whereby better results are anticipated.

The New York Cable Railway Company obtained from the General Term of the Supreme Court, Dec. 28, an order against their opponents to show cause why the Commissioners report should not be remanded to them for further hearing. The order was obtained in pursuance of the announcements made by the company's counsel immediately after the decision of the Court of Appeals was handed down. The company alleges that by that decision the validity of its charter was confirmed and that all that is necessary for it now to do is to reconvene its original commission—which adjourned without day and is alleged to be still alive—to have that body pass once more on details of plans in accordance with the suggestions made by the Court of Appeals, and to get a report in accordance therewith approved by the General Term. This company proposes to construct a network of cable railways, extending to a total length of seven miles, throughout the city.

The Manhattan (Elevated) Railway Co.'s report for November shows that 13,214,573 passengers were carried again 8,955,976 during November, 1885. The gross receipts for last November amount to \$667,482, while those of November a year ago were \$590,892.72. The increase is 4,258,597 passengers and \$76,589.28, an average increase per day of 147,953 passengers and \$2,552.97 in gross receipts.

The first cable road in this city, viz., the One Hundred and Twenty-fifth Street Cable Railway has been in successful operation over a month. President Lyons, Vice-President Hart, Superintendent Robertson, and other officials of the Third Avenue Railway Co., are so delighted therewith, that they (and the directors) have resolved to have the cable system adopted on Third Ave., at a cost of \$1,500,000; work of construction to be commenced in the spring. The new cable road now opened runs across town to Harlem. The Tenth ave., cars are switched on to the One-hundred-and-twenty-fifth-st. cable at the junction of the street and avenue, and go to the eastern terminus below First ave., but the two lines are entirely independent of each other. No transfer tickets from one to the other are given. Passengers wishing to go up to Carmansville, Fort Washington, or any other point reached by the Tenth Avenue line are directed to take the large cars, while those going to Fort Lee or any other point across town take the smaller cars. The fare on both lines is five cents.

*Troy.* A cable railroad is proposed between Troy and Lansingburg.

#### OHIO.

*Akron.* Street railroads are projected from the Sixth Ward to the business center and the western portion of the city, with a probable extension up West Hill. D. E. Hill, sewer pipe manufacturer, is interested.

*Carryville.* It is reported that the Cincinnati Railway Company, Cincinnati, will build a cable route to Carryville.

*Cleveland.* The Broadway and Newburg Street Railroad Company has at last been granted the right of way on Orange Street, on condition the company would not work its employees more than 12 hours per day.

#### PENNSYLVANIA.

*Allegheny.* A cable line is to be built on Federal Street.

*Meadville.* Samuel Y. Love, 125 S. 11th St., Philadelphia, will build a street car in Meadville.

*Norristown.* A street railroad is projected to the Montgomery Cemetery and the Insane Asylum. Henry C. Wentz is interested.

*Philadelphia.* The case to decide the right of the Traction Company to charge a fare of 6 cents is postponed till January 7.

*Pittsburgh.* The Pittsburgh, Oakland & East Liberty Street Railroad has been sold to the Central Transit Company, a Pittsburgh and Philadelphia syndicate headed by Wm. L. Elkins, and P. A. B. Widener, Haverford, cor. N.

41st, Philadelphia. It will be converted into a cable road as soon as work can be commenced, and the machinery will be contracted for shortly. The construction will take six months.

A steam or electric railroad is projected on Squirrel Hill, to connect with the cable line. J. R. Murdoch, John Scott, and others are interested.

#### RHODE ISLAND.

*Woonsocket.* The street railroad has been formally opened; there are two routes, one to Central Falls, and one on Cottage and Dexter streets.

#### TENNESSEE.

*Cleveland.* The Cleveland Street Railroad Co. has been incorporated, and has contracted for rails and ties.

*Memphis.* The Memphis City R. R. Co. (the old company) fell into "hot water." It failed to fulfill the terms of its franchise. And, anticipating that the chancery court would cancel its charter, the new company, the Citizens' Street Railway Co., filed a petition for right to use the old tracks. But "after weeks of labor, disappointment, broken pledges, and all the routine work necessary to bring discordant interests to harmonize, a consolidation of the two street railway companies has been consummated." Bonds to the amount of \$1,000,000, to be known as consolidated bonds, will be issued. Of this amount \$500,000 of the bonds will go to the stock of the old company, and \$500,000 of bonds will be held in trust for the redemption of a like sum of bonds issued some time ago by the old company and now outstanding. The proceeds of the sale of \$100,000 of bonds which are at par, will be expended in purchasing new cars and relaying the tracks and otherwise improving the property of the old company. The remaining \$300,000 of bonds goes to the stockholders of the Citizens' Street Railway, or new company, who will at once retire the \$200,000 of bonds now held by them. In all probability, Messrs. Napoleon Hill, George Arnold, J. C. Neely and R. B. Snowden, of the Citizens' Street Railway; R. D. Frayser, Thomas Barrett and J. T. Frost, of the Memphis City Railway, will be the Board of Directors. One of the first four named will be president, and Thomas Barrett will be superintendent.

*Nashville.* The McGavoch and Mt. Vernon Street Railroad Co. is building two new branches. Mr. Deaderick is superintendent.

#### TEXAS.

*Cleburne.* The Cleburne Street Railroad Co. has been incorporated by E. M. Heath, O. S. Heath, C. W. Metz, J. A. Eastwood and M. M. Crane. Capital stock, \$25,000.

*Corsicana.* The Corsicana Street Railroad Co. has been incorporated by L. L. Lester, J. E. Whitesells and W. J. McKee. Capital stock, \$50,000.

*Terrell.* The Terrell Street Railroad Co. has been incorporated by Wm. A. Disborough, of Dallas, and Franklin Priest. Capital stock, \$7,500. The line will be a belt, two miles long.

#### VIRGINIA.

*Richmond.* The Richmond Union Passenger Railroad Co. has been incorporated by V. Heckler, Jr., John F. Barry and others.

An extensive street railroad system is projected by J. B. Pace, E. D. Christian and others. It will encircle the city, will have a connection with Manchester by a new bridge, and will be operated by dummy engines until the plans for working by electricity are perfected.

### Foreign Street Railways.

*England.* The street railway cable system is being adopted in the "center of England," as Birmingham (the headquarters of the Liberal Caucus) is sometimes called. And our esteemed trans-Atlantic contemporary, the *Pall Mall Gazette*, speaks of it thus: "The wire cable system of tramway propulsion, which has been extensively adopted in America—in San Francisco and Chicago—and which has largely occupied the attention of practical tramway men in England for some years, is about to be adopted in Birmingham. The Central, which is the largest of three Birmingham tramway companies—its steam and horse, tram

and omnibus routes now extending almost sixty miles—is now proceeding with the work of substituting the cable system for the hilly horse-tram route which runs through a principal part of the town. The length of the line will be a little over two and a half miles. If, however, the workings of the new system prove satisfactory a considerable extension will take place. The driving machinery building and car sheds are in course of erection at one of the termini. It is anticipated that the line, the gauge of which is to be three feet six inches, will be opened for traffic in the spring, probably not later than May. The new route will be worked in connection with the steam cars running in the company's other districts. The rails will therefore be of similar construction—girder rails with groove rolled in—about 100 pounds to the yard. It is stated that the corporation will be the constructors and proprietors of the line, of which the company will be only the lessees. Two thousand five hundred pounds per mile has been deposited with the municipal body to pay for removing the cable rails, if the system does not prove satisfactory, but such a contingency is not apprehended. The expenses of constructing the line is estimated at £9,500 per mile."

*France.* Next year railways will have been introduced fifty years in France. The event will be celebrated next summer, at Paris, with all the honors due to the birthyear of such a great economic revolution. There are four proposals, which will probably all be carried out. They are: An international exhibition of railways and all the accessories connected with their development; an international railway congress to study the question of rates, security, comfort, and other kindred topics; an official ceremony at the opening of the new line from Paris to Saint Germain; and the erection of a statue to Marc Seguin. It is rather strange, however, that street railways are ignored, although this system of intra-mural travel is in great favor in Paris. Probably this element of modern civilization may find more prominence in the Paris Exhibition of 1889. The guarantee fund for that has already been "more than subscribed," viz., over three-and-a-half million dollars. The committee hope to make it a splendid success. The projected Paris metropolitan railway, however, does not seem so promising; and it will be a great disadvantage to visitors if that will not then be in operation.

*China.* Recently the news arrived of the opening of a general railroad in the Celestial Empire. We are now informed that a cable tramway is being constructed from Hong Kong to Peak, which, from the description received, has similar surroundings, etc., to those of the Mt. Adams and Eden Park Inclined Railway, at Cincinnati. Peak is the residential suburb of Hong Kong.

### Business Notes.

THE Lane & Bodley Co., of Cincinnati, Ohio, have just closed the contract for all the machinery for the engine room of the Mt. Auburn Cable Road, of that city; two 24x60 engines, with boilers; the driving and tension machinery; leading sheaves, etc., are included in the contract. This is the second heavy cable contract awarded this well-known concern within a few months, the other being for the Mt. Adams & Eden Park line.

THE Metropolitan Street Railway Co., of Boston, has bought the right for putting on all its cars, the improved and patented sand box now being manufactured by the Car Track Friction Appliance Co., whose announcement appears in our regular advertising columns. Sand boxes of this description have been sent for practical use to the following street railways: The Cambridge Consolidated street railway; the Gloucester City street railway; the Haverhill & Groveland street railway; the Natick & Cohituate street railway; the Hannibal street railway, Missouri; the Rochester City & Brighton street railway; Fitchburg, Oakland & E. Liberty street railway; Mount Adams & Eden Park Incline railway, and the Des Moines Broad Gauge street railway. The Feigel Car Co., of New Utrecht, L. I., are using "The Reliable sand box" for their new Connolly motors.



# The Street Railway Gazette.

VOL. II.

CHICAGO

FEBRUARY, 1887.

NEW YORK

No. 2

## Lewis Lyon.

Lewis Lyon, president of the Third Avenue Railroad Company, was born in Birmingham, England, fifty-four years ago; and he comes from old English stock. After attending school (in Birmingham) for a few years, he came to this country, and completed his studies at the University of the City of New York. After engaging in various financial pursuits, Mr. Lyon turned his attention to railroading; and in December, 1876, he was elected treasurer of the Third Avenue Railroad Company, which position he resigned, in February 1879, to assume the duties of president of that corporation. Just at that time the Third Avenue branch of the New York elevated railroads had been completed; and, contemporaneously with the assumption of his duties as president of the surface road, the first elevated trains were run.

Many were the predictions, made by people who were supposed to be competent judges, as to disastrous effects which the operation of the elevated roads would have upon surface street car companies, and no corporation was to be injured worse than the Third Avenue company. Notwithstanding their ominous prediction, the ridicule of the press, the realization of timid holders of the company's stock, which caused the price to fall in the market one hundred per cent., Mr. Lyon went at his work with a tireless and irresistible will; and his prediction that the operation of the elevated road would in the end prove beneficial to his corporation subsequently proved to be correct.

The large number of people who, by the new means of transportation, availed themselves of the means of securing cheap and comfortable homes in Harlem, instead of in Jersey City and Brooklyn, favored the Third Avenue surface road; and the patronage of this new element more than counter-balanced the amount lost by the company upon its "long travel." When these results became known, the stock of the Third Avenue company advanced rapidly, and, in the early part of 1886, sold at 330—the highest point reached in its history.

Two events in the course of Mr. Lyon's administration of the affairs of this corporation have a wide-spread interest;

namely, the introduction of the cable traction system of street railways into the State of New York, and his management of the great strike of the employees of the Third Avenue company in February, 1886—the latter event and its proceedings being watched by the populations of this continent and of Europe.

Cable railways had been in successful operation in California for some years prior to the introduction of the system here, by the Third Avenue Railroad Company; and the chief objection, lodged against successful operation here, was the difference in climate and its effect upon the "slot"

rail, or rail through which the steel connection rod runs between the car and the cable—many believing that the comparative severity of New York winters would cause the slot to contract, and also that ice and snow would render passage along the road difficult, if not impossible. Mr. Lyon, however, induced his Board of Directors to build the Tenth Avenue cable road, the construction of which is marvelous. The central depot, from which the propelling power emanates, is probably the finest structure of its kind in the world. The road-bed is laid with solid blocks of concrete, and every accessory is of the latest and most improved design.

This road, together with the property upon which the depot stands, cost the company \$1,500,000. And when it is considered that the line runs through that portion of the island which is very sparsely populated, from 125th to 196th street, and that anything approaching a return to the holders of the company's stock upon this branch, could not reasonably be expected for many years,

it will be readily seen in what high esteem the directors and stockholders of the company held their president, and that they had the greatest confidence in Mr. Lyon's judgment as to the practical operation of this new mechanical power. It has now been in operation nearly two years; and so complete has been its success, that a new branch has been built through 125th street, from river to river, superseding the horse power formerly employed thereon, and that, too, is working as perfectly as could be desired.

Gratified by the success of its two new roads, the company now proposes to run the cable traction over its entire





route along Third Avenue; and in a short while we will no doubt see the largest and most famous horse railroad in the world in the van of improvement, and readily sacrificing its horse-power plant and equipment, for the sake of supplying the public with the latest and most modern invention, which science has perfected for the transportation of our great city populations.

The great strike which occurred on the part of employees of this company, beginning in February 1886, will long be remembered, because, even to those indifferent souls who care not for others as long as they are not scorched, it had a deep and all absorbing interest. And upon the issues of that contest hinged important results. It was a question of whether an employer had the right to engage and retain in his service one who, in all respects, fulfilled the requirements of his position, without regard to his being acceptable to his co-employee.

The local organization of the Knights of Labor, to which the great majority of the employees of this company belonged, demanded and insisted that some eight other men should be dismissed from the employ of the company solely for the alleged reason that they were not fit to be associated with those who belonged to the Knights of Labor. A peremptory demand was made upon President Lyon for the dismissal of these men. Mr. Lyon just as peremptorily declined to accede to such a demand; and, in consequence, the great strike was developed. For eight weeks travel was suspended over a road which operated three hundred cars a day. Its depots were watched by the old employees, to prevent recruits being brought into the company's service. Its officers were shadowed; messengers were stopped in the street on their way to the company's offices, and their letters opened. Libelous reports with reference to the mortality list of the company's horses were circulated through the press. Opposition free stages were run along the company's whole line by the rebellious employees; its cars were broken; new employees were stoned, and every conceivable pressure was brought to bear upon the company to force the company to accept the employees' terms; but all to no purpose.

It was for a principle that Mr. Lyon contended—the principle which, from time immemorial, has been handed down, that “every man shall do with that which is his as he pleases, so long as his neighbors are not injured”—and, keeping that principle in mind, the firm president of the Third Avenue horse-railroad was at length triumphant. The strike failed miserably—as it should have done. Right triumphed, and anarchy and socialism were thoroughly beaten. That was a heroic battle, fought and won, not for the Third Avenue company alone, but in the interest of every property holder throughout the country. And that strike carried with it lasting lessons, the results of which cannot be over-estimated.

While thus holding the fort firmly in the battle of life, and contending with innumerable difficulties on every side, Mr. Lyon is always in good humor, and easy of access (which is not often the case with those occupying similar positions). And his very affable disposition, and fondness of a good story, secure for him a large circle of admiring friends.

And strikes are not the only difficulties that Mr. Lyon has successfully contended against. In an interview with a New York *Times* reporter, who asked his experience as a railroad president in connection with personal damage suits, Mr. Lyon said, as reported in the issue of that paper for September 24th, 1882, as follows:

“Few people have an idea,” said President Lewis Lyon, of the Third Avenue Railroad Company, a few days since, “of the evil energy displayed by a certain class of so-called lawyers in hunting up and investigating claims for damages against corporations, especially railroads. The instant that mention of an accident, however trivial, appears in the newspapers, they rush to the person injured, to secure the case. About eighteen months ago a little boy, playing “tag” in the street, ran in front of one of our cars and was killed. His mother lived in Lafayette Place, and was an authoress, I believe. Before noon on the day succeeding the accident,

according to the statement of the unhappy mother's landlord to our agent, there were seventeen letters received from lawyers offering to prosecute a claim against the company; five more lawyers called in person, and one fellow who said he was a private detective was so persistent in his demands to see the lady—who had fled to Jersey City to escape the mob—that he had to be thrown out of the house by force. No suit has ever yet been begun in that case, from which fact it would appear that the lady has had the advice of an intelligent and honest lawyer, to the effect that the company was not liable. I only mention the case to show how those lawyers swarm, like the Egyptian locusts, wherever they scent a fee. Why, not long since there was one limb of the law who had in his pay, regularly, an attendant in Bellevue Hospital. We were puzzled to know how it was that one chap got so many cases of this class. He must have had a dozen against us at one time, and more against other horse railroad companies. We found that the instant an accident case was brought into the hospital, that attendant would send for him, and he would either wheedle or bully a patient into consenting to his prosecuting the claim for damages, even before the accident was reported to the police. Of course we made complaint to Commissioner Hess against that enterprising attendant, and he was removed. Good doctors do not hunt patients, nor do good lawyers hunt clients. The fellows who practice getting business in this way are not good lawyers, nor even honest ones. They instigate litigation, regardless of whether there is any justice in the claims they set up; take cases “on speculation”—as the famous suit of Bardell against Pickwick was taken—but always manage to chisel a few dollars out of their deluded clients for “expenses”; and if they ever succeed in worrying the company into a compromise or settlement, they will take the lion's share of the money paid, or perhaps all of it.

“We have had several cases in which men have come to us wishing to settle claims which had been in lawyers' hands for months without any progress, so far as they could learn, and upon reference to our books we have been enabled to show them that we had settled, and that the lawyers had fobbed the money long before.”

### Street Railways In Mexico.

On or about the 23rd December last, Mr. Alas, the Consul for Mexico in Chicago, mailed us a report of street railway operations in the city of Mexico, which he had been good enough to obtain from his government specially for the *GAZETTE*. We regret that the document did not reach us; and we wondered why the report was so long coming.

Several of the regular letter carriers had left for their Christmas holidays, when the papers for the *STREET RAILWAY GAZETTE* were dispatched from the Mexican Consulate, and the probability is that a substitute carrier dropped the miscarried communication into the wrong box.

We have received copy of said report (to hand just as we are going to press), and observe that it comprises street railway returns for 1885, for the city of Mexico only. Mr. Alas informs us that the Mexican Minister of Public Works has promised to get the 1886 report of street railways, throughout the Republic of Mexico, issued without delay, and the Mexican Consul declares that a copy of the same shall be handed us by special messenger. We return Mr. Alas sincere thanks for taking so much trouble to furnish us with such valuable information, that cannot fail to be of great interest to our readers—at home and abroad.

A MONTHLY CALENDAR, of surpassing neatness, and with excellent white paper for its monthly tablets, whereon special memoranda may be conveniently written, has been issued by the well known manufacturer of street car wheels, springs, etc., namely Frank H. Andrews, of 545 West 33rd street, New York. The card is of a lovely cream color, in the centre of the upper part of which is a handsome quadruple illustration of the Globe Iron and Steel Works, a street car, a track sweeper, and a track laying operation. This is the most admirable street railway calendar we have yet seen.

### The Sprocket Wheel Cable System for Street Railways.

There is no longer a question as to the practicability of substituting the running of wire rope for horses, in operating a street railway in any climate; the only important points for further discussion and demonstration being: (a) First cost of construction, and (b) cost of operation and maintenance. It is the interest account, plus wear and tear of rope and machinery, that has deterred many street railway companies from adopting a cable system ere this, in preference to horse-power.

It is not forgotten that there are various claims in favor of different forms of "traction motors"; but, so far, none of these devices have thoroughly overcome the most formidable difficulties presented in the operation of surface street railways; and the decided weight of preference is for some form of power that is positive—such as propulsion by a cable.

It may be conceded that the best way to operate a line would be with a cable running open—above ground—in case a street could be used exclusively for running street cars, the rope to run on friction rollers, as is done in mining operations. But since a city street must be used for general traffic, the rope when used must be under the surface. It follows, however, that with such a construction, the following arbitrary points must be allowed:

- (1.) No grip of any kind can be used.
- (2.) The tube must be cleaned out by brushes, or other devices, attached to the cable.
- (3.) A sprocket wheel of some form must be used to transfer the motion from the cable to the car.
- (4.) To regulate the speed of the car, without varying the speed of the cable, the motion of the sprocket wheel must be controlled by friction.

Having regard to the foregoing conditions, Mr. R. E. Graves, of Dubuque, Iowa, and Mr. H. W. McNeill, of Oskaloosa, Iowa, undertook the construction of a trial line of 3,000 feet long, on the track of the Chicago West Division Railway Co. on Lake, beyond 40th street, through the Iowa Iron Works Co., of Dubuque, Iowa.

The patents covering the system include one issued to Lafayette Parker, of Davenport, Iowa, in 1880, together with a series of patents issued, between that year and 1885, to C. W. Rasmussen, of Chicago; and another series, covering particular designs used in this construction, issued to H. W. McNeill, under whose personal supervision the line in question was built.

It is only claimed for the trial line, which is now in successful

operation, that it is a crude model; but it fully demonstrates the entire practicability of the system; and this is the verdict of the practical men who have examined it, among whom may be named Mr. Dewitt C. Cregier, Superintendent of the Chicago West Division Railway Company.

The plates accompanying this article are from drawings made for a new construction at Sioux City, Iowa, where this system has been contracted for by Messrs Pierce and Hedges of that city.

#### THE TUBE.—(See Fig. 2.)

The tube is 7½ inches deep, by 6 inches in width, and will consist of three pieces, namely, the bottom plate, of boiler iron twelve inches wide by one-fourth thick. The other two pieces are each a Z bar of proper size, with one-inch lugs rolled in the lower corners, to carry the cable trucks. When in place the upper flanges of these bars are of unequal width and do not meet, leaving a slot or opening in the top of the tube of five-eighths of an inch at one side of the center. The larger Z bar is riveted to the base plate, while the smaller one is bolted from above down, so that it may be removed.

It is aimed in this construction to have strength enough in the Z bar to carry a six ton load on the edge of the slot without deflection, and to so fasten the rails of the track and the tube to the same substructure that their parallelism must be maintained; if one moves, all must move.

The tube is built in sections of thirty feet, and the ends of the base-plate will be fitted together in cast chair plates; to the sides, at the joints, are riveted V-shaped plates, thus allowing for contraction and expansion.

At intervals of about three hundred feet, varying with the circumstances, a section three feet long is cut out of the bottom of the tube inside the rails, and a pipe attached running to a catch-basin sunk between the inside rails of the two railroad tracks.

From the basin, connection is made with the sewers. A steel brush attached to the under side of each traveling truck sweeps all accumulations into these basins; the liquids run into the sewers, the solid matter is lifted from the basins in sheet-iron buckets placed there for this purpose.

In changing an established line from horse power to cable, the tube can be laid down in sections, working between midnight and six o'clock A. M., so that there need be no interference with the regular operation of the road, and hence no suspension of revenue.

It will now be seen that the construction of the tunnel is entirely avoided, and herein lies the principal economic feature of this system. To tunnel a street in a city, taking

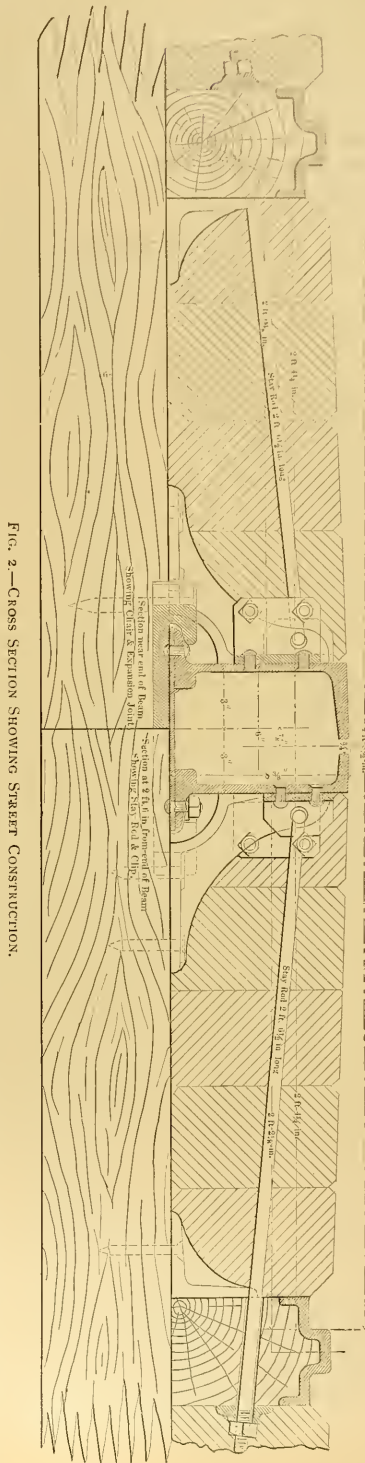

FIG. 2.—CROSS SECTION SHOWING STREET CONSTRUCTION.



Broadway, New York, for instance, is a formidable undertaking. Aside from the iron yoke work, concrete foundations and masonry essentially necessary, the engineer must meet the sewerage, gas, water, steam, electrical and pneumatic tube systems. All these interests must be subjected to serious annoyance and loss, and the city railway making the improvement must, during construction, suffer a direct loss of revenue amounting, alone, to many times the gross cost of the Rasmussen plant.

It is apparent, too, that all reasonable grounds for opposition to granting a railway company a charter for a cable road disappeared with the tunnel.

THE ROPE.—(See Fig. 3.)

For all ordinary traffic the patentees advise the use of a steel cable, wire centered, one inch in diameter. On this is fastened by compression, 8 inches apart, cast steel buttons  $3\frac{1}{2}$  inches in diameter, one inch face. Every 6 feet one of these buttons is widened from its center, downwards, to form a journal and oil box, through which passes the axle that carries the wheels of the truck. This fastens the rolling two-wheel truck to the cable. At the engine house a horizontal wheel of diameter equal to the distance between the centres of the railroad tracks, with its face or edge slotted to receive both the buttons and trucks, is driven by a friction drum attachment to the engines. The rope is thus moved by a positive pull and can not slip. Here again the friction is taken from the cable and put upon the driving drums.

Horizontal curvatures are made easy by the use of sprocketed or arm wheels, of small diameter, projecting through the side of the tube and reaching over to, and against, the rope, so forcing the maintenance of alignment between the slot in the tube and the running rope below.

Vertical curvatures are taken care of by having upper and lower tracks in the tube, the little trucks riding either lower or upper track as the case requires.

At the outgoing side of the driving drum, in the engine house, the ordinary form of traveling drum, slotted, with compensating weight attached, is used to take up the slack of the cable.

It will be noticed that the friction driving drum arrangement is an important step ahead.

By setting these friction wheels at, say, one-half the breaking strain of the cable, which would be two and one-half times its working load, such a thing as breaking the cable becomes impossible.

The rope runs one-fourth inch clear inside of the edge of the slot in the tube, and the arms of the sprocket wheel projecting into the

tube, and catching the buttons on the cable, do not wear upon the cable at all.

The patentees make the claim that there is no friction

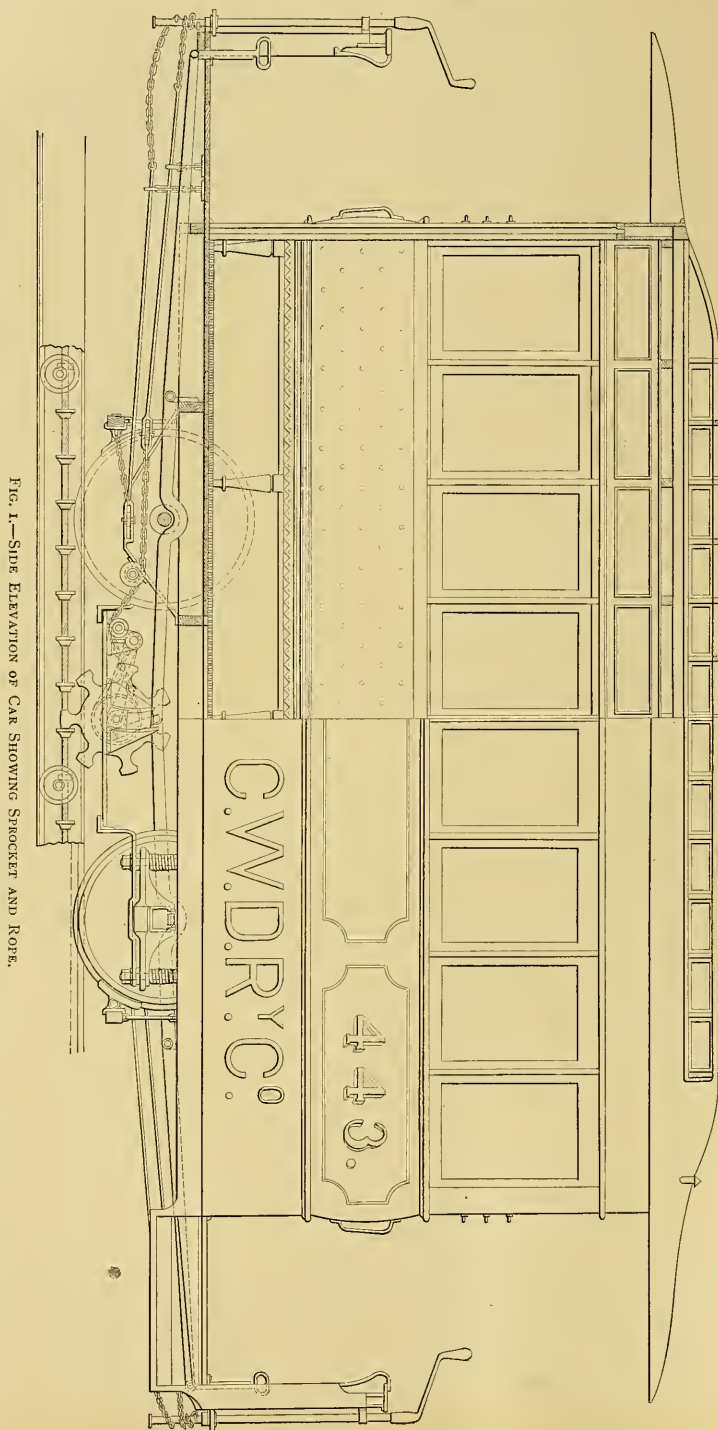

FIG. 1.—SIDE ELEVATION OF CAR SHOWING SPROCKET AND ROPE.

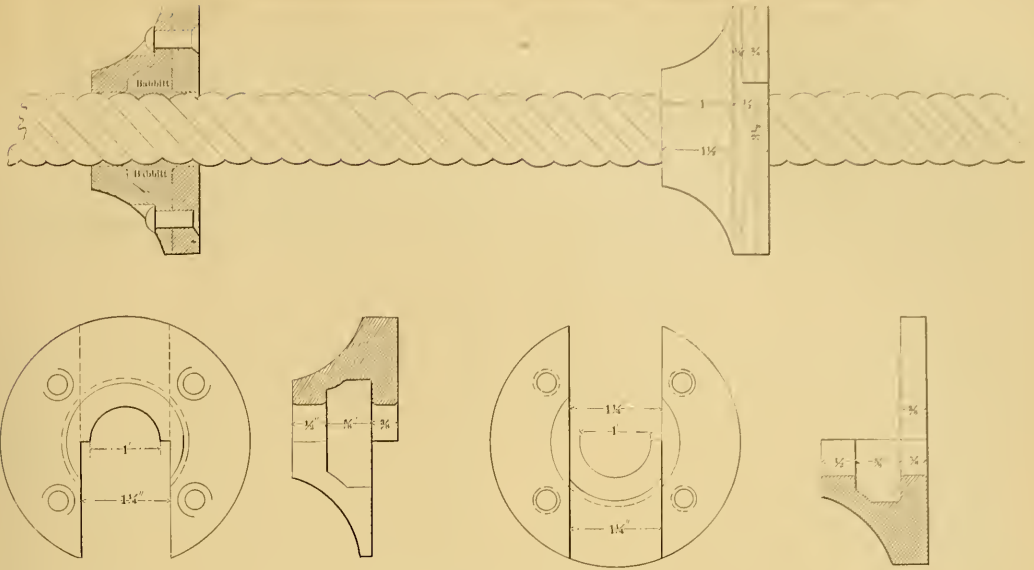

FIG. 3.—DETAIL OF BUTTON, ETC.

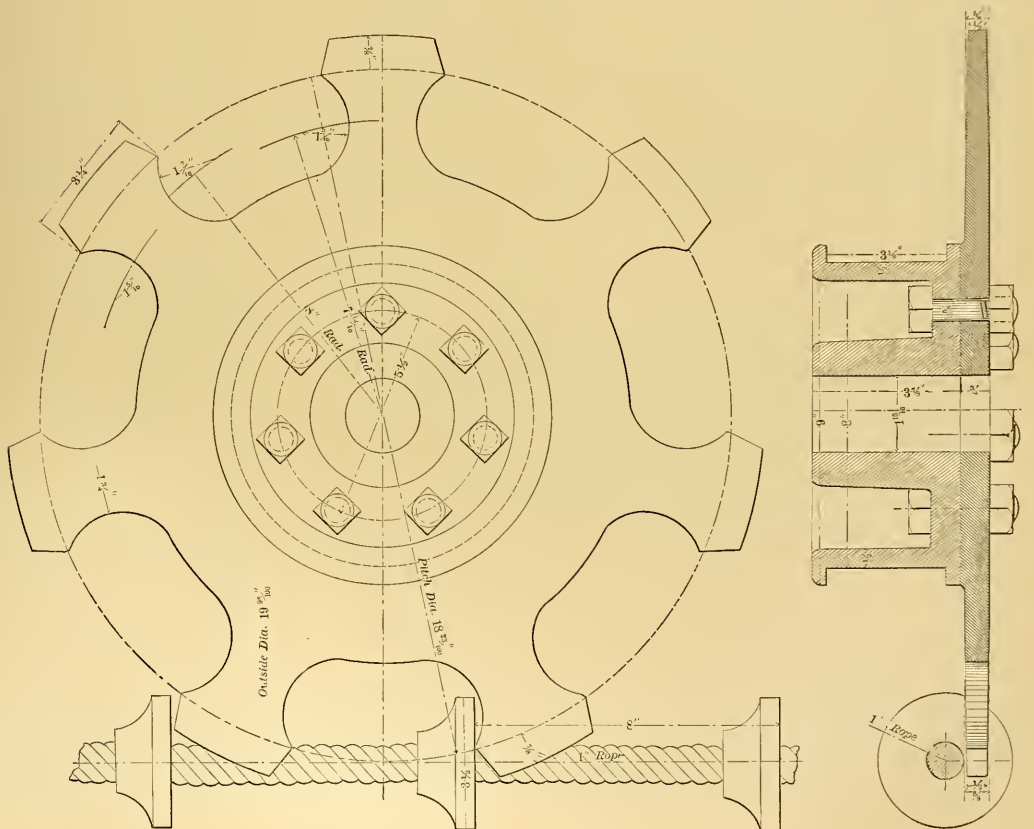

FIG. 4.—SPROCKET WHEEL.

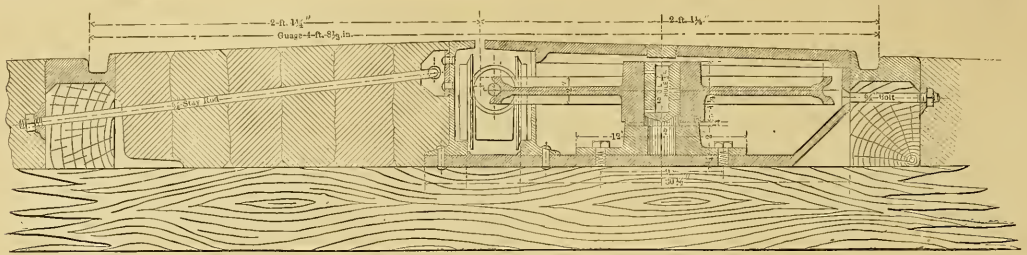

FIG. 5 (b).—CROSS SECTION CURVE CONSTRUCTION.

wearing point upon the cable at any place in the system, and its life can safely be guaranteed to be ten years.

Haswell gives the extreme stretch of  $1$  and  $\frac{1}{8}$  inch wire rope hemp centered at  $\frac{3}{4}$  inch in six feet. This is less than  $\frac{1}{8}$  inch between the buttons, and is allowed for in the slots cut in the face of the drums; the buttons acting as clamps reduce this possible stretch over one-half.

#### SPROCKET WHEEL.—(See Fig. 4.)

To transmit the motion without jar, from the moving cable as described, to a passenger car resting on track above it, an eight-armed sprocket wheel of cast steel is constructed.

The web and hub of the wheel are cast in one piece, with a flange projection from the side to carry a strap brake. Upon this are riveted the eight arms named, at such distances that the *pitch line* is exactly eight inches, to mesh into the running ratchet or buttons below on the cable, which are eight inches apart, and these arms project down and into the box five inches below its surface.

Now to the boxes or journals that carry the railway car axles, and from the inside of the wheels, two two-inch by one-half inch bars are attached, bent down in the centre to within three inches of the track, and towards each other until, at the centre of the car longitudinally, they are, say, twelve inches apart.

This then constitutes a frame on which rests boxing, through which runs the axles, that carry the sprocket wheel revolving between the two bars. Its boxing also slides up

and down in guides seven inches, and this hoist of seven inches can be made and still clear the bottom of the car.

Now it is clear that if this sprocket wheel be left loose, and in connection with the running rope below, it will simply revolve and the car will stand still.

But one end of the strap brake about it is attached to the frame, and the other to a bar lever from which a chain runs to a winding post on each end of the car. Now let the driver tighten up his hand wheel, and as he arrests the motion of the sprocket wheel the car must move until, when entirely arrested, the car goes as fast as the cable.

It again the chain from the sprocket wheel brake is wound about the winding post from right to left, and the chain from the car brake goes about the same post from left to right, one motion of the wheel in the hands of the driver puts on the car brake and lets off the sprocket brake, and *vice versa*, thus putting the car absolutely under the control of any man who knows enough to turn a wheel.

The sprocket wheel has a lateral motion of two inches, to take up unevenness in the track gauge, but always centres when out of gear by strap springs resting against the ends of the sprocket axle, fastened to the outside of the boxing.

The sprocket wheel may be put upon every car in the service, which is then, indifferently, a grip car or a horse car, with less than two hundred pounds added weight, at the will of the driver. So it follows, any one part of a system may be cable, and yet any car in the service will run on any part of the railway company's system.

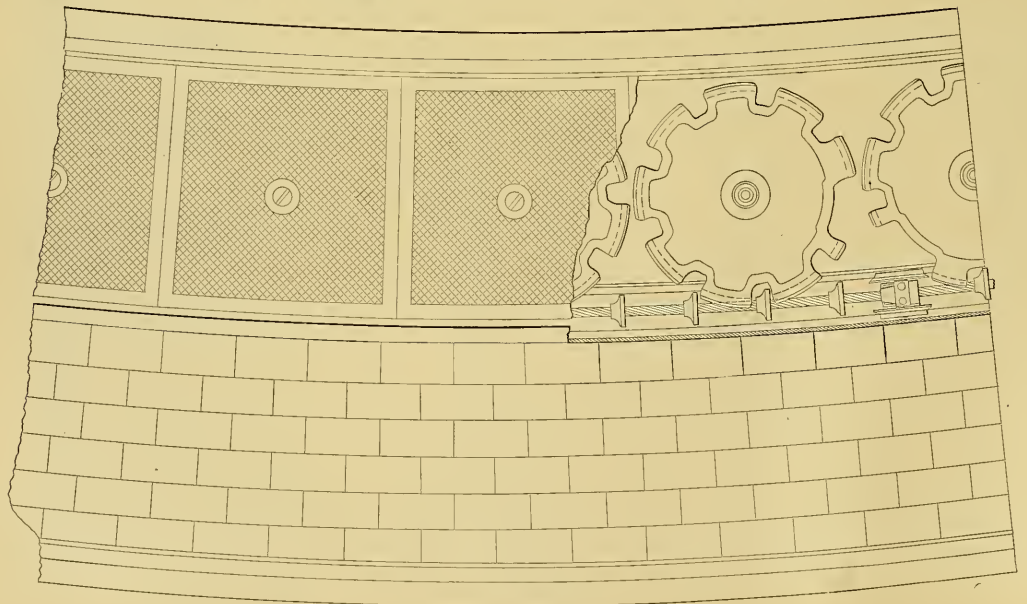

FIG. 5 (a).—PLAN VIEW CURVE CONSTRUCTION.



TRUCKS.—See Fig. 6.)

The wheels are six inches in diameter, made of cast steel, and bored for one inch axle. The axle is of soft steel with ends riveted tip into a countersunk face of the wheel so making all fast. The tread of the wheel is made concave, and babbitt metal rings are run into place, so deadening any noise in operation. The journal that surrounds the axle is open for one-third of its circumference below the centre, and goes on down forming an oil box to hold oil and waste, thus adopting the exact principle of the railway journal and oil box. This truck is held rigid, fore and aft, by buttons, but is allowed free motion around the rope, so permitting the rope to twist freely in running.

ratchet to its place when the bridge is closed. The result is a positive pull up, on to, across, and off the bridge.

CROSSINGS. This system will cross itself at any angle. Here again is used a supplemental link belt operated by the moving cable, taking up the pull on a sprocket arm, whether in motion or at rest, where the buttons leave it, and so pulling the car positively over the crossing either way. Of course the tubes running in one direction are depressed, and pass under the tubes running the other way.

The trial line, now running in Chicago, demonstrates beyond criticism the following facts :

1st. No exclusive grip car is needed. Each car is its own motor, and the machinery (one wheel) is below the

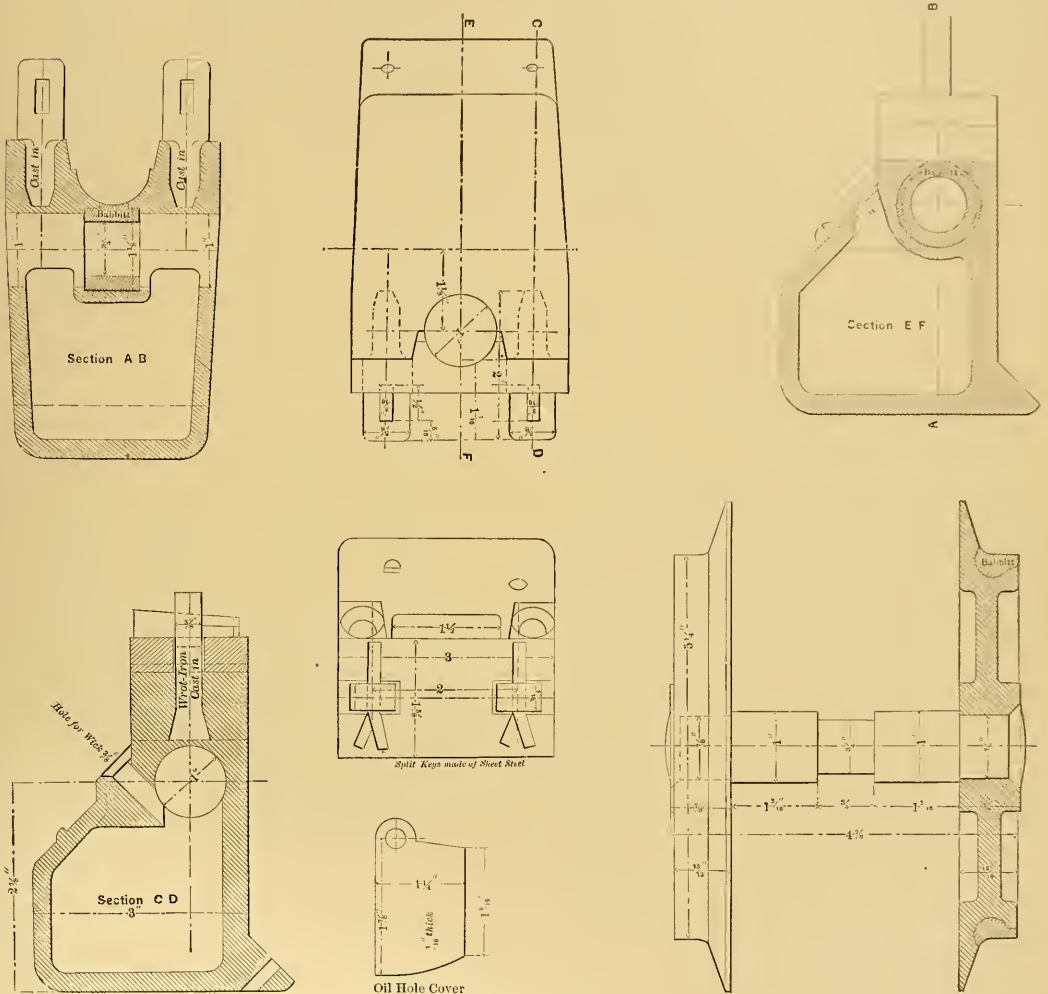

FIG. 6.—DETAIL OF TRUCK.

BRIDGES. To cross a draw bridge that swings either way, a supplemental tube rope and end drums rest on the bridge. Opposite these end drums, on the banks, run end drums of the system turning or terminating there. Then a supplemental or connecting link belt is run positively, from the bank drum to a friction connection with the bridge drum. This connecting link belt revolves on two sprockets, two feet in diameter, resting in a frame of their own, which frame is movable longitudinally into a pocket in the bank when the bridge is to be opened, and run back by a spur wheel and

floor of the car, out of the way and noiseless.  
 2nd. The driver stands on the platform where he belongs, and has only the same winding post to handle he always had. No experts are needed. It takes less skill to manage the car than to drive a team.  
 3rd. The tube is a perfect self cleaner, under all circumstances, in all kinds of weather.  
 4th. There is no friction wear on the cable, and it is not possible for the driver to strand or break the cable, by carelessness or ignorance.

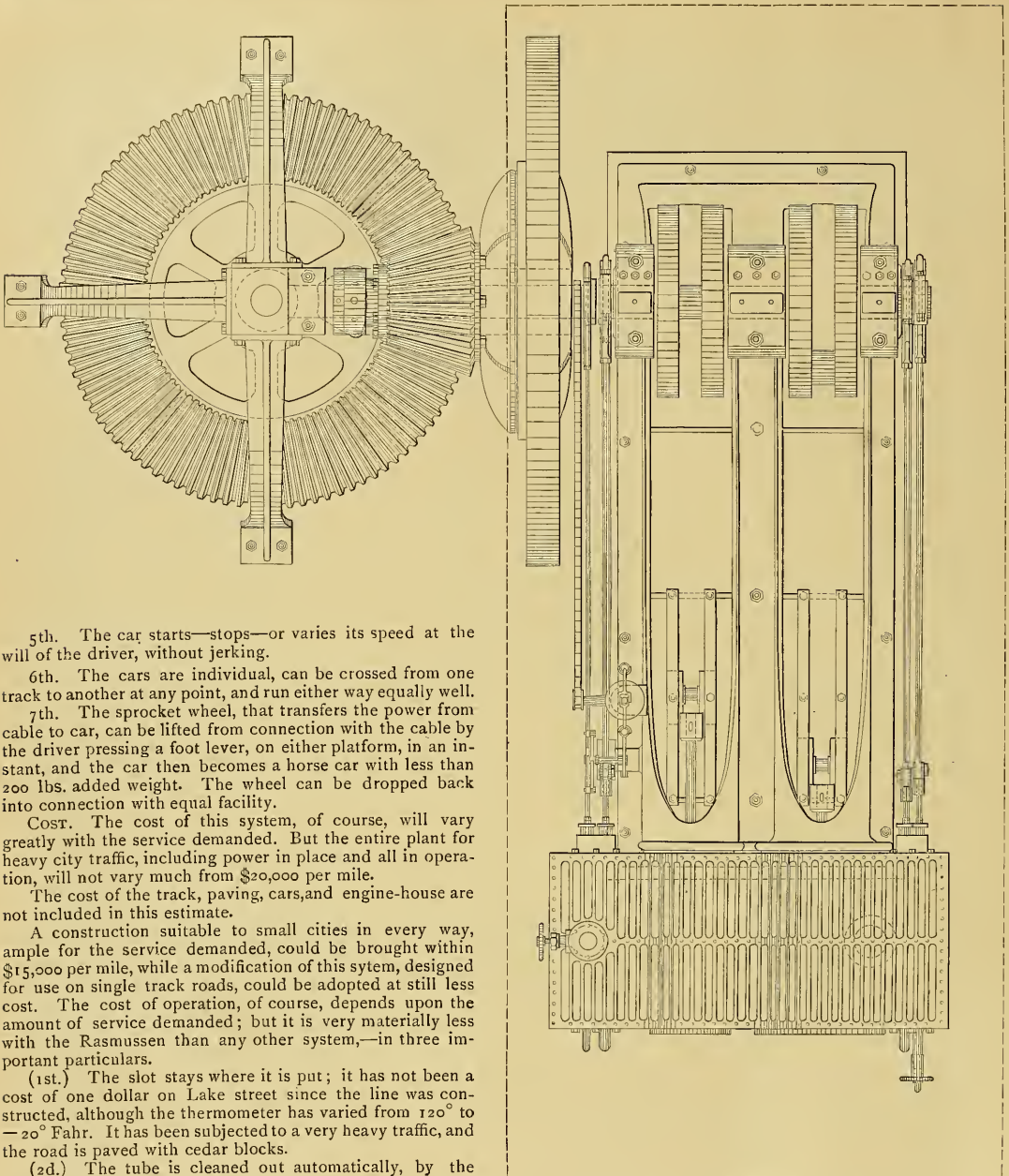

FIG. 7.—PLAN ENGINE DRIVING DRUM.

5th. The car starts—stops—or varies its speed at the will of the driver, without jerking.

6th. The cars are individual, can be crossed from one track to another at any point, and run either way equally well.

7th. The sprocket wheel, that transfers the power from cable to car, can be lifted from connection with the cable by the driver pressing a foot lever, on either platform, in an instant, and the car then becomes a horse car with less than 200 lbs. added weight. The wheel can be dropped back into connection with equal facility.

**COST.** The cost of this system, of course, will vary greatly with the service demanded. But the entire plant for heavy city traffic, including power in place and all in operation, will not vary much from \$20,000 per mile.

The cost of the track, paving, cars, and engine-house are not included in this estimate.

A construction suitable to small cities in every way, ample for the service demanded, could be brought within \$15,000 per mile, while a modification of this system, designed for use on single track roads, could be adopted at still less cost. The cost of operation, of course, depends upon the amount of service demanded; but it is very materially less with the Rasmussen than any other system,—in three important particulars.

(1st.) The slot stays where it is put; it has not been a cost of one dollar on Lake street since the line was constructed, although the thermometer has varied from 120° to -20° Fahr. It has been subjected to a very heavy traffic, and the road is paved with cedar blocks.

(2d.) The tube is cleaned out automatically, by the brushes, instead of by hand with scrapers.

(3d.) There is no wear on the rope, except that due to its running around a nine foot drum in the engine house; to these points must be added what appears to be one of the most important results demonstrated by the experiment, namely that the loss of power due to moving the plant is less than 25%, instead of the 75% which is generally conceded to be the actual loss in other cable systems. This is directly due to two causes: (1st.) Instead of using friction drums, in the engine house, around which the rope must be wrapped repeatedly to prevent it slipping, the power from the engine is delivered to the rope by a positive pull of one slotted drum against the buttons. (2d.) Instead of conveying the

cable through the tube over small friction wheels, each of which in turn throws a small segment into the rope. In this construction the rope is carried on supporting trucks that move with it.

So far from overstating this saving, the actual test is that less than three horse-power will move the engine, engine-house machinery, and 3,000 feet of cable which passes around one curve of 45 deg. and one of 50 deg. besides the return drum. The most careful investigation of this claim is invited. The Rasmussen Cable Co., of 59 State Street, Chicago, Ill., are the owners of this system.



## Construction, Equipment and Maintenance of American Street Railways.

BY AUGUSTINE W. WRIGHT.

*Continued from page 5.*

### OPEN CARS.

A style of car denominated "open car" and designed for warm weather has come into quite general use.

I am of the opinion that the increased revenue due to the superior comfort offered by this type of car during hot weather, thereby inducing patronage that would not have sought transportation in a "close car," does not warrant the increased cost incurred. About 75% more capital is invested in cars, when the open-car is provided in addition to the "close-car." The amount of room required in the car house is doubled, taxes and insurance are increased, and an expense is incurred if a rain or other storm requires a change during the day to the close cars, affording passengers better protection. The custom having once been inaugurated in a town must continue, and it would be useless to argue further as to the advantages or disadvantages.

The "open car" is usually entered from the side, a step being provided the entire length of the car and platforms, on each side for ingress and egress.

The liability to accidents is largely increased by this construction. With a "close car" the company cautions its patrons to enter and leave via the rear platform. In this event if he or she should slip or fall, it occurs *behind* the car wheels, whereas upon an open car the danger of getting under the wheel is largely increased. The records will bear me out in the statement that a larger percentage of accidents occur upon "open cars" than upon "close-cars."

his force in producing horizontal motion, and none in lifting. Clearly, his line of draught, in this event, should be nearly horizontal.

Suppose, for illustration, that he was so attached to the car that his pull would be entirely vertical. All his strength in this event would be exerted in lifting the car up off the track. No horizontal force could exist, and the car would not move forward.

Cars measured by me were found as follows: Box Car had the drawbar  $25\frac{1}{2}$  inches above the track. Open Car 30 inches. I measured half a dozen horses of average height and found the distance from track to tug attachment upon hames to be 52 inches, and the distance along the tugs from hames to draw bar to be with circular evener 97 inches, with straight evener 90 inches.

In the accompanying diagram (Fig. 41) let A represent the draw bar to which the horse is attached. Let B represent the point at which the tugs are fastened to the hames and E F the grade or level of the track on which the horse travels.

If we figure for a "Box Car," with straight evener, the length along the line A B is 90 inches. The height B F is 52 inches. The height A E or C F is  $25\frac{1}{2}$  inches. This subtracted from 52 leaves 26 $\frac{1}{2}$  inches, the height B D. This divided by the length gives  $\frac{26.5}{90} = .294$ , which is the sine of the angle B A C, about  $17^{\circ} 7'$ . The cosine is .95566 which subtracted from 1.00000 leaves .04434 the versed sine, or C D.

Now if a horse is pulling 200 lbs. 4.34% is exerted in lifting the car, (8.68 lbs.); not in producing motion. Upon entering a grade rising 6 inches in the above distance, 6.747% of his total force exerted would be lost.

The most advantageous height at which to attach the horse to the car, therefore, *considering the line of draught*, is level with the point upon the hames, to which the tugs are attached. In a hard pull the horse throws himself forward against his collar, and this height is lowered probably 4 to 6 inches. It is evident that the heights of the horses vary, and an average height must be adopted.

Should the point at which the horse is attached to the car be *higher* than the tugs at the hames he will exert his power at a greater disadvantage, than when it is the same distance too low, for on the last assumption he is lifting up a portion of his load, but in the first case actually adding to the load by the downward pressure.

Mr. Pugh, of the John Stephenson Co., happening to be in Chicago, the above was submitted to him and he requested permission to show it to Mr. John Stephenson. The latter wrote as follows:

"Our Mr. Pugh has put in our hands your dissertation on the height of draw bars for street cars.

"It is a subject of great importance—is not well understood, and errors expose to serious practical evils. In fact it is a case where 'science' without practical experience will mislead.

"I have read carefully your article, and hope it will not be given to the public in that form, for it may do you harm professionally, while leading some astray.

### "HORSE SERVICE

"The most severe part of the horse car service is in the frequent starting of the car, in doing which he wrings himself, slips, and falls. He falls because he slips, he slips because his feet do not hold their grip to the pavement. The angle of the trace adds to, or diminishes the grip, and, with the low point of draft, lifts the load while increasing the foot grip; doing what (or more) an experienced teamster does when his horse is on a strain, i. e., mount on his back to give him more weight, and therefore, better footing. An old and expert teamster, if he is going to haul a log, will bring his horses close up and get his chain at the underside of the log—or if a stone boat is to be moved, the horses will be brought close up to the work; in all these cases securing the footing while lifting the load.

"Again. The horse is made with his shoulder at an angle, so that the trace must be low at its back end, and even at a lower point than a right angle with the shoulder, in order that the collar may incline rather downward than upward, in

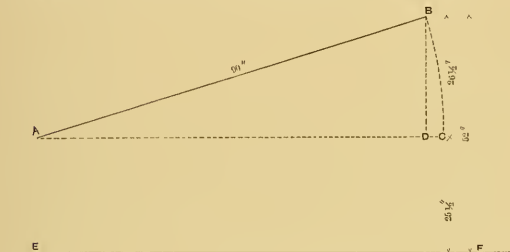

FIG. 41.

Open-cars are made with stationary and also with reversible seats. My experience causes me to prefer the former.

Some people endure discomfort in riding backwards, and as a rule the seats facing forward are the first occupied, but the space that can be afforded between the seats, being limited by the length of the car, passengers can get out from the center of a seat with less inconvenience, when they face each other, having more room, than with reversible seats, and the car has less carrying capacity.

Ladies object having to crowd past men, or the reverse, in the limited space afforded with reversible seats.

### HEIGHT OF DRAWBAR.

The height above grade at which the horse is attached to the car, affects the amount of force he must exert in producing motion, moving the car forward. The point at which a horse is attached to a car, should be higher than upon a wagon or other vehicle. The reason is obvious. In pulling a load upon any surface other than a railroad, the wheels encounter obstructions of greater or less height. The horse must therefore be hitched to the load at such an angle, with traces inclining *upwards*, that a portion of his force is exerted, not in producing motion, but to the best advantage in *lifting* the load over obstructions. Now these obstructions are not assumed to exist upon a street railway, for the tracks are supposed to be laid to a uniform line. If this be true, the horse, having no obstructions over which to lift the car and its load, should be so attached to the car, as to exert all

which latter case the collar will press on the horse's gullet or wind-pipe, and he may be choked, as sometimes occurs.

"But, it is to be observed that the point of draft is influenced by other considerations, viz: While it is true that a horse will *start* the greater load with point of draft near his heels, yet this is not the best for a horse whose load is light and his gait fast, as in a trotting wagon. A horse with a hard mouth will pull the wagon by his bit and bridle; hence such vehicles have the shafts crooked up, the front wheels comparatively high, and the point of draft well up.

"It is found more congenial to the horse who travels quickly, and of course, with lighter load, to have his point of draft above his heels sufficient to allow him to lean against his collar, while he throws his body forward as he steps. Another consideration is the desire to get the horse near to his work, and in cities to bring the horse as near to the car as possible. We have found, as in our Broadway omnibuses, the drivers preferred to shorten their traces and bring the horses close to the whistle tree bar, so that the horses' heels were under the front carriage.

"The result of close observation of this subject for a lifetime makes us satisfied with the present method on cars, of having the drawhead 24 to 26 inches above grade, which is now, and has long been our rule when unobstructed."

To this I replied:

"I concede all you say about starting. My article on 'Horse Power' gave tests showing this strain to be 4 to 7 times greater than the force required to maintain motion. In an article on 'Paving' I advocate the use of selected cobble-stone. *This* gives the horse a firm foothold. Now what is the use of making him *lift* a portion of his load of car and passengers to give him a *firmer* foothold?"

"As explained in my paper, which you have done me the honor to read, the requirements for a vehicle running upon a smooth iron way are quite at variance from a wagon or other vehicle traveling upon earth or pavement. For the latter a *lifting* pull is essential (as in the case of your log and stone boat). Regarding the horse's neck. With a tug of our length and height of drawbar, i. e. 25½ inches, the lifting strain is so great that the collar is pulled *down* on the top of his neck; and the fact that most of our horses having sores from the collar have them *on top of the neck*, indicates that it is due to this cause.

"Now, as to your own *practice!* You will concede that the heaviest loads are carried upon 'open cars'; yet on our open cars, as built by you, the height of drawbar is 30 inches!"

"Observation alone will convince an experienced eye that the horses propel the open car with greater ease!"

"In Baltimore, with heavy grades, the horses are attached nearly 30 inches above grade, and the comparative ease with which they pull was so pronounced that it at once attracted the attention of Mr. Goodrich, general manager of the St. Paul and Minneapolis street railways. He spoke to me about it. I said there was an advantage in pulling upwards; that it tended to hold the horse down; that frequently when a horse had been unable to pull a loaded wagon, I had seen him succeed with the added weight of a man upon his back, etc.

"Careful consideration convinced me of the difference between the wagon and the car.

"The added *weight of the man* would be equally advantageous in either event, for the horse pulls chiefly by throwing his weight upon the collar. In a *hard* pull, the heavier the strain upon the horse, the lighter is the burden upon his front legs, because in pressing against his collar the latter supports the front portion of his body, and the weight is transferred to the hind legs, which are consequently more firmly pressed upon the ground.

"I submit the foregoing with diffidence, for I appreciate the extent and profundity of your knowledge, gathered during so many years' experience; but I must say that 30 inches seems the best height of drawbar!"

To the above Mr. Stephenson replied:

"Yours of the 4th inst. is at hand, regarding horse car draw head. The importance of the subject, together with my desire that you should stand right, before the public, induces this reply to your rejoinder:

"1st. A lifted load, while securing footing for the horse, also diminishes his service by the lesser journal friction and the greater ease with which the wheels surmount the bad joints and unclean surface of the rails.

"2nd. Horses keep in better condition when in work with 'high points of draft in open cars.' Our knowledge is adverse to this: *i. e.*, we understand that during the open car season, the horses become so worked out that they take till the next spring to recuperate.

"The high draft of open cars is an accident in their construction, and not because it is beneficial.

"3rd. Baltimore cars, as we understand, are not more successfully operated by a 'high draft.' The street railways of Baltimore are less profitable than in any other of our large cities in the 'temperate zone,' and there is less average efficiency in their horse power, and their cars average smaller per horse.

"Galled necks of horses is not the result of the point of draft on our cars. Poles will do this. The weight of the collar and traces, and chafing of harness, are common causes; for in the trotting wagon, with the traces horizontal, the necks of horses chafe, and the 'Dutch collar' is substituted to relieve the horse's neck.

"Spring drawheads are of vital importance in operating horse cars, and are a great relief in starting, as also at each stop of the horse. A pair of horses, of a ton or more weight, put in motion, will give an impulse in starting the car, though the muscular energy of the animal should be for the moment passive; but when the two co-operate, the car is started with less strain to the animal, and furthermore, a spirited horse, finding his load coming, takes courage to continue his effort, which he would not do if the load was unyielding. Therefore the elevated drawhead is to be deprecated, because it prevents the use of a spring drawhead.

"VARIOUS NOTIONS.

"To humor our customers, we have made between 50 and 60 different styles of drawheads, of which we now have patterns. Which is

BEST

"We have solved by deductions from scientific study and practical experience of 55 years, and, when left unembarrassed, we give to our customers this 'BEST:'

"No one can be more interested than ourselves in having the BEST, as that is our motto.

"We are careful students of advanced science, and the developments of experience, in both of which we have aggregated as no other has had the opportunity, and our interest is manifest by this correspondence."

Considering this letter in detail:

"1st. Every 15.6 pounds *lifted* by the horse suffices to keep 2000 lbs. in motion!" As to bad joints; I went out on our track at random upon the receipt of this letter, and examined forty points where our cars stop. In Chicago, to make better time and save horse flesh, the street cars stop only at street intersections, or in the middle of blocks over 500 feet in length. The stopping place in the latter case is marked by a sign "Cars Stop Here."

I found if the car was stopped, as it should be, with the rear platform opposite the cross-walk in the street, that *thirty-six* out of the forty stops would occur *not* at a joint. 90% of these stops, therefore, derive no benefit from a low drawbar.

2nd. I never stated that "horses keep in better condition when in work with high points of draft on open cars." Quite the reverse is true. This is due, however, not to the high drawbar, but to the fact that the loads are greater on the open car, and the latter is used in *hot weather!* It is from heavier work and the heat that horses require a winter to recover. I am sorry to know that the height of drawbar upon the car designed to carry the heaviest loads, in the most unfavorable weather, has been the result of an accident in Mr. Stephenson's construction; although in my opinion this has been a fortunate accident, and resulted in benefit to the horse railways.

The unprofitable character of the Baltimore street railways is due, not to the high drawbar, but to the steep grades, and well nigh unlimited taxation. Their condition would be worse with the *low* drawbar.—*To be continued.*



## History of Street Railways.

(Continued.)

Singularly enough, cab proprietors were not so much troubled about the adoption of street railways. It was not supposed that the street car would affect the cab—at all events not so much as the omnibus. But it is a remarkable fact that, as soon as street cars obtained a clear course in New York, they were so much liked that (to quote from a record of the period) “cabs are almost disused in the streets through which tramways are laid. At Providence, in Rhode Island, there are about fifteen miles of street thus provided, which (among a population of 65,000) carried three millions and a half of passengers in the year 1868.” Before that time, street railways had not only come to general use in New York, Philadelphia, Baltimore, New Orleans, etc., “in the land of tramways,” as well as in other countries, but they had gained “the unquestioned sanction of the public.”

### IV.—STREET RAILWAYS OPPOSED IN ENGLAND.

It is a remarkable coincidence that just as the first street railway was being constructed in the United States (the New York and Harlem line), Goldsworthy Gurney's “steam coach” was running along the roads surrounding Regent's Park, London, England, experimentally. “It was a strange-looking machine, on four wheels, with a pair of supplementary wheels in front, to serve as a steering apparatus.” W. Bridges Adams “watched all the subsequent doings of Maceron, Ogle and Sumner, Scott, Russell, Hancock and others, and came to the conclusion that the whole scheme was a practical fallacy.” Steam locomotives on common roads would not work satisfactorily on country highways, much less on populous streets.

But some improved means of transit was becoming more imperatively necessary as the population of London, and the large towns of England increased. McCulloch endorses the dictum that “next to the introduction of money, and weights, and measures, the formation of good roads gives greatest facilities to commerce, and contributes more powerfully perhaps than anything else to the progress of improvement. They have been denominated national veins and arteries; and the latter are not more indispensable to the existence of individuals, than improved communications are to a healthy state of the public economy.” In other words, as the free circulation of the blood is essential to health in human beings, similarly proper means of transit should be provided to meet the requirements of increased population. And after some years practice in the States, a Frenchman carried the street-railway scheme to Paris, “with all its imperfections,” says Mr. Bridges Adams. “But to inculcate England with it required a genuine American, and he appeared in the person of Mr. Train, who showed energetically the good folks of Birkenhead the paying chance of the scheme.” That was in 1860. But he encountered a flood of opposition. “He was beset with difficulties from first to last; vested interests combined to baffle him; parish and county authorities, omnibus companies, cab owners and drivers, carriers and carters, all joined in the opposition; and the public were not sufficiently familiar with the conveniences of the system to espouse the cause of the projector.” For one thing, George Francis Train was too energetic, too wise, too self-reliant—“too clever by half”—and too eccentric. He laid his street railway in London (after obtaining partial success in Birkenhead) in 1861; and in some parts the scheme broke down utterly. In writing thereon, in 1869, Chambers state “that people tell us there is a chance now of obtaining tramways [this term was becoming generally used for street railways in Great Britain by this time] on some of our roads; and the question is, whether such tramways would be a wholesome check on saucy cabbies, grasping bus-owners, and monopolizing railway companies. Our past failure in this matter ought not to discourage us. Mr. Train laid down a tramway, a few years ago, from Westminster bridge to Kensington; the adventure broke down; but it is now known that the shape and arrangement of the rails were not what they should have been. Moreover, certain eccentricities in the promoter of the scheme tended to bring it into ridicule; and we all

know how powerful a weapon ridicule may become in discouraging an adventure. We must look to foreign countries, and to English cities and towns beyond the limits of the metropolis, to see the real working of the tramway system when fair-play is given to it by the proprietors, by the road-engineer, and by the public.”

The tramways then laid down by Mr. Train consisted of two wrought-iron plates, each 5 in. wide, weighing 50 lbs. to the yard, and bent at near the center to a depth of  $\frac{3}{4}$  in. below the general level of the road. These plates were fixed to longitudinal timbers, embedded on concrete, and the gauge of the line was that of ordinary railways—4 ft. 8½ in. And, as Mr. Thomas Measam observes, these trams proved dangerous and obstructive.

Mr. Train, moreover, thought to clear his course considerably by giving the scheme such a name as “omnibus railway.” It seems that the letter of “Omnibus,” inserted in the preceding chapter, had great effect on him; and by erroneously presuming that the omnibus stood as high in public estimation in England as in America, he essayed to anticipate the omnibus argument by adopting a name that would nullify its force. But “omnibus railway” was not at all euphonious to Englishmen, for the omnibus system over there was in a sad plight—especially in London, where, one public censor, “more irate than the rest,” stated that the omnibusses “are dirty, frouzy, ramshackle packing-cases on wheels, which would disgrace the capital of a third-rate power. There is nothing to recommend them. They are neither swift nor orderly, nor well appointed nor clean. Passengers at alighting are observed to have quite a *chevaux de frise* of dirty yellow straw attached to trousers or dress. Some of them have no doors; so that the rain and snow and biting winds pelt in among the passengers as freely as if they were unsheltered. The inside seats are curiosities of hardness, the frouzy plush being apparently stretched over macadam of great knobby power; windows have stuck until they have become fixtures; while the knife-board is reached by bits of iron which bark our shins.” Thus the omnibus interest was not the most formidable obstacle to street railways in England. And besides the obnoxiousness of the term omnibus, the name “railway” was also very prejudicial, inasmuch as the term conveyed an idea of danger in the minds of ordinary English people. “One argument against the system,” says W. Bridges Adams (writing in 1860), “has been founded on the supposition of danger to the public by reason of a street railway. This arises simply from the term ‘railway,’ and the supposed speed involved. But the risk of a railway-omnibus is really far less than that of an ordinary omnibus, from the fact that it runs on a fixed track, and that passengers know what part of the road to avoid, and the brakes applied to the rail-omnibus afford the means of stopping much more rapidly.”

The objections most strongly urged against Mr. Train's “omnibus railway” consisted in the monopoly it was alleged would be afforded to certain “omnibus” (*i. e.*, street car) proprietors against all others; in a difficulty in stopping the vehicles when once in motion; in the obstacles anticipated to gas and water companies on streets where the rails would be laid down; “and in the interference with traffic which must inevitably take place whilst the tram-road itself is in process of construction.” And Chambers wisely observe (when Mr. Train was running his railway omnibuses in Birkenhead), “with reference to the last and most tenable argument against tram-roads, that it is impossible to suppose leading thoroughfares can be handed over to private companies for the purpose of having ‘omnibus railways’ constructed, it is natural to suppose that the experiment will first be made in the widest approaches, and that it will not be tried among the narrower channels until the merits of the plan have been thoroughly tested. The great danger against which it is requisite to guard, is the possibility that the efforts of interested parties, or the official ‘cold shoulder,’ may defeat an effort which at least promises to achieve so desirable an end as the acceleration of street traffic.”

The “omnibus railways,” however, did not succeed.

(To be continued.)

## Mechanical Traction on Street Railroads.

NOTES ON EXPERIMENTS IN EUROPE, 1870 TO 1880.

BY E. E. RUSSELL TRATMAN, JR. AM. SOC. C. E.

During the last decade great advances have been made in the construction of street railroads, and as the roads have improved, and the call for rapid transit has increased, more attention has been given to the various modes of mechanical traction designed to replace animal power. In Europe the improvement of the track has made much greater advancement than in this country, and the question of mechanical tractive power has also received more attention. There have been many difficulties to overcome, and many more still remain to be overcome, before a reasonably perfect system can be established; and the writer has gathered from various sources the following notes of what has been done in Europe between 1870 and 1880, which notes he thinks will be of general interest. He begs to express his obligations here to those gentlemen who have supplied valuable information, especially Mr. H. G. Calcraft, Secretary of the Board of Trade, England.

In view of the long suburban routes of surface railroads now being worked by horses, in many American cities, it seems reasonable to conclude that there is a large field for the adoption of mechanical traction, even though, at present, public opinion is generally opposed to the introduction of such traction on city streets; and the writer has a strong opinion in favor of steam engines for such lines of street railroads. It should be mentioned that the Hughes and Merryweather engines are entirely distinct from the car, as are those of other makers herein mentioned, except where especially alluded to as "steam cars" or "combined cars," which cars contain their own motive power.

### GREAT BRITAIN.

In 1870 (previous to which year several street railroads had been authorized) the "Tramways Act of 1870" was passed, its purpose being to facilitate the construction of such roads, and to place under official supervision the construction and operation of the lines, as well to provide a certain control over their promotion. The Act contained power to authorize steam traction, but this power was not called into use until 1876, when the Wantage Tramway Company asked the Board of Trade to confer upon it—by a provisional order—the right to work their already authorized road by steam; after careful consideration by the Board the order was granted, and in the same year similar powers were granted to the Vale of Clyde Tramway Company in Scotland. In 1878, eighteen applications were made to the Board for provisional orders, aggregating ninety-seven miles of track and over \$2,500,000 capital, most of them asking for power to operate by steam. In the session of 1878-79 thirty-three street railroad bills and thirty-two provisional orders were brought forward, aggregating respectively 209 and 147 miles of new lines, and \$13,760,000 and \$4,505,000 capital; thirteen of the orders included power to use steam traction; but before granting this the Board of Trade sent an inspecting officer to examine and report upon the various localities, and as a result of such report, and in consequence of the narrow, steep grades and sharp curves on several of the routes, only four companies obtained the desired power. It may be interesting to consider those places where experiments have been made.

*Batley.* Early in 1878, an engine from Leeds, drawing one car, was worked experimentally on the line running on one continuous street through the towns of Batley, Birstal and Dewsbury; the street being in some places only 24 feet wide, and having some heavy grades. The engine worked satisfactorily, as regards traction, and the exhaust steam was fairly condensed by passing through a series of pipes arranged on the top of the engine.

*Bristol.* An engine built by Fox and Walker, of Bristol, was, in 1878, worked on a line containing a grade of 1 in 18; the engine, with loaded car, weighing 11,200 pounds, could stop and start on this grade and was well under control; it was subsequently sent to Rouen. Another line,

about 1.75 miles in length, was worked by steam power, from November, 1880, to November, 1881. The line was of standard gauge, single track with sidings, and was constructed on Kincaid's original system of channel rails (3.5 inches wide with a 1.25 inch groove) resting on iron chairs on a concrete foundation; but the track required considerable repair while the line was worked by locomotives. There were five engines, built by the Hughes Engine Company, which company contracted for hauling at a mileage rate of 14 cents per car mile; only one car, with a capacity for forty passengers, being attached. As a witness of the working of these engines the writer can state that their performance was not satisfactory; they broke down several times, the coupling was of an awkward design, there was considerable noise and jar from the machinery, and many complaints were made as to the escape of steam and noxious gases, which rendered the outside seats of the car very unpleasant, while several accidents occurred, owing to the frightening of horses. It should be stated that there was strong and absurd antagonism to the locomotive on the part of tradesmen and frontagers; the road included some very sharp turns and steep grades, and since that time many improvements have been made in the engines constructed by this company. An official of the tramway company recently stated to the writer that while he had no doubt that the permanent expense of working with locomotives would be considerably less than with horses, yet the streets on the route were so narrow and crooked, and there was such difficulty and objection, that after a twelve months' trial the engines were replaced by horses.

*Edinburgh.* In 1877 as much as 20 cents per mile was paid for horsing the cars by contract, owing to the heavy grades. Several engines were tried, Scott-Moncrieff's pneumatic car was too heavy, Grantham's steam car and Merryweather's engine were not sufficiently powerful, and the Hughes engine was not powerful enough for the 1 in 22 grade (1.5 miles long), though it worked on other sections. In 1878 a combined engine and car, by Robertson and Henderson, Glasgow, worked with considerable success, taking a grade of 1 in 13, containing two sharp curves, with ease. There were three cylinders, the third being only used on the steep grades. The boiler was on the right-hand side of the entrance, occupying the space of two passengers; an automatic governor was fitted to regulate the speed. The line was of standard gauge, double track, costing from \$7,000 to \$8,000 per mile. The routes were very hard for horses, and though four were used at many points there were constant complaints of cruelty.

*Leicester.* In 1876 one of Hughes' engines was worked for two months on a section of track about 4 miles long, there being then 7 miles of street railroad. The line was standard gauge and single track, with sidings at intervals of from 200 to 300 yards; the profile was fairly level, with the exception of a grade of 4.5 per cent. for about .75 mile just outside the town, on which the engine frequently stopped and started; the streets averaged 24 feet in width. The engine ran through the populous part of the city, the speed being 6 miles per hour; outside the city it varied, on one occasion reaching as high as 20 miles per hour. No fuel was carried, the firing being done at one end of the trip, and the condensed exhaust steam was thrown on the rails; on occasion it could haul two of the cars, which were small, accommodating only 16 or 18 passengers.

*Mumbles.* A horse tramway had existed since 1804 along the side of the road from Swansea (Wales) to what is now the watering place of The Mumbles; and in 1864 it was used for a passenger line. In August, 1878, the Swansea Tramway Co. leased this line for \$8,000 per year, and put a locomotive on, against which, as a nuisance, an injunction was soon obtained. The line was then purchased by a private party and worked with locomotives, which emitted very little steam or smoke, but the appearance of the train at night was very startling, in consequence of the fire showing beneath the engine. The speed was nominally limited to 10 miles per hour, but frequently reached 17 miles per hour. The length of the line was 4.5 miles, and the track was laid very similarly to that of a railroad, with steel



rails on cross ties (originally on stone blocks). It may be mentioned, as an interesting fact, that horses were not frightened as much by ordinary locomotives as by those that were boxed in.

*Portsmouth.* Engines built for Bilbao, Spain, were worked experimentally, in 1878, with satisfactory results. The act of putting on steam closed a valve in the smoke-stack, and the gases from combustion were discharged under the engine, instead of passing upward, so that scarcely any noxious gases escaped from the stack during the trip. The condensation of the steam was nearly perfect.

*Sheffield.* In January, 1877, a Hughes engine was experimented with. It worked without trouble on a grade of about 5 per cent., and its speed averaged 6 or 7 miles per hour.

*Stoke-upon-Trent.* A provisional order was granted, in 1879, to the North Staffordshire Tramway Co. for a line on which steam or other mechanical power might be used.

*Vale of Clyde.* This line, a little over four miles in length—comprising two sections, one from Glasgow to Govan, the other from Greenock to Gourrock—was authorized in 1871, and in 1876 power was obtained to work the line by steam. The Glasgow section, however (about 1.5 mile long), was the only one upon which steam traction was employed. The street upon which the line was laid varied from 29 feet to 34 feet between curbs, was practically level, and had stores and dwellings on each side. The line was standard gauge, double track, and laid nearly in the middle of the road. The track consisted of grooved steel rails of the ordinary English pattern. The act required that all loaded coal cars should be transferred over the line from the Govan railroad depot to the several shipbuilding yards along the route, and the only way in which this could be done, owing to the size of the flanges of the wheels, was to have a shallow groove and let the railroad cars run on the wheel flanges, which method proved satisfactory. There was considerable traffic over the line, both of the usual light character, and heavy freight, such as boiler plates, machinery, etc. Steam traction was first employed in the early part of 1877, when seven Hughes engines were put on the road. Their performance was satisfactory, and they were well under control. In 1878 the inspecting officer of the Board of Trade reported that they behaved fairly, but that there was a greater emission of smoke and steam than there should have been, while the average speed—8 to 9.5 miles per hour—was in excess of that permitted by the by-laws, which was 8 miles per hour, and 4 miles per hour on passing through movable facing points. There was a speed register on the engines to show the engineer at what rate he was running, and an automatic brake mechanism shut off the steam when a speed of 10 miles per hour was obtained. The engine tank reached to within 3 inches of the surface of the road. The cars, with inside and outside seats, had a capacity for 40 passengers. The Hughes Engine Company contracted for haulage at 11 cents per mile for 40 passengers, and 15 cents per mile for over that number. In 1878 the price was 10 cents per mile; the 11 cents rate included the engineer, and no fireman was carried. These rates were very low, and it was estimated that on lines having steeper grades they would range as high as 14 cents per mile for the steam power alone. Trains were run with a headway of 7.5 minutes and on Saturdays of 5 minutes.

*Wantage.* The Wantage Tramway Co. was authorized by a provisional order, in 1874, to construct a line 2.5 miles in length from Wantage (Berkshire) to the Wantage-road station on the Great Western Railway. In 1876 application was made for a further order permitting the working of the line by steam power; there was no opposition, but as this was the first application of its kind very careful consideration was given to it, and an inspecting officer was sent down to examine the road. Upon his report the order was granted, but stringent regulations were imposed, providing for the authority of the Board of Trade to order certain appliances and to exercise a general control of the operation. The order required that the train should be stopped should a horse be frightened at it, but the House of Commons subsequently struck out this clause as unnecessary. The line was opened

in October, 1875, with horse traction, and steam power was first employed in August, 1876. The line was laid along the side of a country road which averaged rather over 35 feet in width, of which the track took up about six feet, leaving nearly 30 feet of roadway, and being out of the way of road traffic. For a distance of about 300 feet the road was only 25 feet in width. The steepest grades were 1 in 44 for 100 yards, and 1 in 47 for 600 yards. The line was single track, with three turnouts, and the track—standard gauge—was laid with bridge rails of the same section as those in use on the G. W. Ry. The passenger line had a terminus at the depot, but there were two junctions with the freight-yard tracks; there was one iron bridge, which was built by the tramway company. There were few houses along the route, and no complaints were made by residents on the side nearest the line, nor from farmers, etc., at gateways. The consent of the road authorities had to be obtained by the promoters, and as they included the whole width of the road within their "limits of deviation," they were at liberty to place their tracks either at the side or in the middle. The former was chosen, as the passage of a traction engine over the road would have damaged the track. The top of the rail was level with the surface of the road, and the lateral play of .5 inch obtained by the form of rail adopted caused a saving in wear and tear as compared with grooved rails. The cost for construction was \$10,000 per mile. In the winter of 1878-79 the line prevented a coal famine in Wantage, as the canal being frozen over, it was the only means by which coal could be obtained, owing to the condition of the roads.

Several engines were tried, including Grantham's steam car, Hughes' and Merryweather's separate engines, and a tank freight engine (boxed in) from the London & Northwestern Railway. Hughes' 8-ton engine satisfactorily hauled two loaded cars under unfavorable circumstances; but Merryweather's engine, weighing 6 tons loaded, was considered the best. A bell or whistle was used to warn vehicles, and the locomotives were boxed in; automatic brakes, acting at a speed of 10 miles per hour, were fitted to the engines; the maximum working speed was 8 miles per hour; the emission of smoke and steam was very slight, and all coaling and watering was done at Wantage. From one to three cars were hauled, one passenger car being ordinarily used, never more than three coal cars (about 18,000 pounds, exclusive of cars) were hauled up the steepest grade at one time. There was a considerable amount of traffic hauled over the road in main line freight cars. Seven trips were made on ordinary days, and 8 trips on market days, the cars connecting with every train on the G. W. Ry.; the trips averaged from 16 to 20 minutes, stops being made where necessary to take up or set down passengers. A car could be pulled up in 20 or 30 feet. The chief engineer, Mr. Stevenson, stated before a parliamentary committee, in 1877, that he thought it a great advantage for a tramway to be able to carry main line freight cars. The horses originally used were hired, it being found to cost 72 cents per journey if they were kept by the company; the hire, including all expenses, was 16 cents per mile, while the steam car cost only 11 cents per mile. On one occasion when horses had to be used temporarily, owing to an accident to the engine, the hire was 60 cents per journey (\$4.20 per day). Fuel, etc., cost only \$2.28 per day. The maintenance of the engines cost about \$500 per year, and the road committee was paid \$100 per year for keeping the road in repair for 18 inches outside the rails. The following notes on the traffic may be *ad rem*: the passenger traffic averaged 2.5 times what it had been with the old stage line, the stage averaging 3 and the cars 7 passengers per journey; in 1878 over 32,000 passengers traveled over the line; during February, 1879, the freight traffic consisted of 1,344,000 pounds heavy, and 297,920 pounds light freight (the heavy freight consisted of stone, coal, lumber, grain, etc.); on the occasion of a Royal visit this line carried 1,500 passengers in a few hours, while it was estimated that a horse car line could not have carried 500; the average number of main line freight cars hauled over the line per day was fourteen.

(To be continued.)

# The Street Railway Gazette.

## PUBLISHERS:

THE WRIGHT-MONROE COMPANY.

Augustine W. Wright,	President.
E. V. Cavell,	Secretary.
S. L. K. Monroe,	Treasurer.

## GENERAL OFFICES:

CHICAGO, - - - NEW YORK, - - - BOSTON.

## C-ICAGO:

9 LAKESIDE BUILDING.

P. G. Monroe,	General Manager.
G. G. Minor,	} Editors.
William Hughes,	

## NEW YORK:

181 BROADWAY.

Henry C. Lockwood, - - Resident Editor and Manager.

## BOSTON:

198 WASHINGTON STREET.

T. P. Pemberton, - - Resident Editor and Manager.

## BRANCH OFFICES.

ATLANTA, Ga.; Chamber of Commerce Bldg., Wm. Minnigerode, Mgr.  
SAN FRANCISCO, Cal; 1222 Bush St., G. W. Fairchild, Manager.

"AMERICAN CABLE RAILWAY CONSTRUCTION" is the title of a work in preparation by Mr. Augustine W. Wright, C. E. of Chicago, the well-known and expert engineer who has written the series of papers on "Construction, Equipment and Maintenance of American Street Railways." The new work will be as complete as possible, and profusely illustrated, giving all attainable information concerning cable railways as built. It will be published in THE STREET RAILWAY GAZETTE forthwith.

STRIKES have now become so familiar that our daily contemporaries can indicate when and where they will occur as accurately as weather prognostics are given. "A street railway tie-up likely" was wired from Boston, Feb. 6; next day "the employees of the South Boston horse railroad, at a meeting which lasted until 3 o'clock this morning, voted unanimously to 'tie-up' the road." So they struck against the superintendent, and for ten hours for a day, instead of twelve. This disease is contagious. So the tracklayers and car repairers joined the strikers. Feb. 9th, the employees of the Cambridge street railway decided to tie-up their road. That makes the number of strikers 90. The companies intend to run their cars, and have them protected by militia, if necessary. And, like the weather prophets, the published probabilities of strikes are not always right. Recently the Chicago papers pointed out strong indications of strikes on the West Division and North Chicago; but Presidents Cregier and Yerkes avoided the storm, and the men listened to the counsels of wisdom. And in no year of the Chicago City Railway Company's history has "the uniform fidelity and earnestness of the heads of the various departments, their subordinates and forces of workmen been more pronounced and manly—holding firmly to the right, in the midst of riotous disorder"—than during the past year. As the management declared at the company's annual meeting, just held, "this forms an essential element, the very basis of all real prosperity for the company, whose delicate relations with all portions of the community are affected by the spirit of its men." A strike was promised on the New York elevated roads, Sunday, Jan. 30th, which did not come off. And probably strikes will soon get out of fashion.

KANKAKEE has been an important steam railway center for some time. It is now to have a new street railway. The City and Suburban Street Railway company was incor-

porated Feb. 10th. Capital stock, \$10,000. Incorporators, Daniel H. Paddock, Amassa Holcomb and Andrew Kerr. The purpose is to construct and operate a street railroad or dummy line in Kankakee, and also to connect that city with the village of Bourbonnais.

"PROGRESSIVE LOS ANGELES" is the caption of newspaper articles and reports on the street railways of that prosperous city—out West. "Los Angeles is the first city west of the Rockies to show the enterprise required to start an electric railroad." The advent of 1887 was signalized by the running of electric trains on Pico street. But the official trial trip was made January 4th, by a party of city officials and others invited by Col. Howland, "the originator and builder of the road;" and he and Gen. Bouton were loaded with congratulations on the marked success of the new venture. The train—which consisted of a dummy and one car—ran a distance of 2½ miles (including a steep grade) in 15½ minutes—"a handsome rate of speed for a street railway." The positive current is transmitted by an overhead wire. The iron, etc., for extending the line to its full length has now arrived, and the whole electric street railway (12 miles) there will be completed by Lady Day, it is expected. The cars are from J. G. Brill & Co., the well-known builders of railway and tramway cars, Philadelphia.

THE horse railroads in Los Angeles are "all to be operated by cables," to which the public "have taken kindly."

## Advantages of the Cable System.

In all the discussions, appearing from time to time, concerning new methods of street passenger propulsion, there is much to interest the street railroad manager and the engineer, and but little that is of interest to, or is even comprehended by the public. Looking at the matter in a lighter and more popular vein, we see much to add to the advantages with which the new methods are credited. The first of those, in the following hasty glance at the subject, have been so often repeated that they will admit of nothing but mere mention:

The filth avoided by discontinuing the use of the thousands of horses necessary to operate great passenger lines by the old method may be measured by the tons of manure removed daily by the gardeners from the street railways stables. An amount equal to a very large proportion of the quantity thus removed being scattered upon the street to be dried by the sun, blown by the winds, and inhaled by pedestrians. The substitution of the neat and airy driving station for the foul smelling stable; and the coal pile for the dung heap, with the possibility of the elimination of the evils resulting from the use of coal by the substitution of natural gas for fuel, are advantages which should alone exert an influence in favor of change.

The silent steam replaces the ringing clatter of the horse-shoe on the hard pavement, and the ears of the nervous and infirm are relieved from ceaseless annoyance during their waking hours. The relief offered by the modern systems to the overworked and helpless brutes has been considered, by leaders in the cause of prevention of cruelty to animals, as sufficient justification for their introduction, even though unaccompanied by other advantages.

A higher object in the same direction is achieved by rendering it possible to provide clean, airy and healthy homes for mothers and children beyond the sights, sounds, smells and vices of overcrowded tenement house districts of the city. The increased speed of the cable, which as yet leads all competitors in the race for popular favor, renders it possible for the father whose time is limited to reach his roomy and consequently distant home, in time to keep up acquaintance with his family. Even this increased speed over the old methods would be of no avail were it not for the remarkable capacity of the cable system for handling a fluctuating traffic; the only requirement for handling this increase being an increase in the number of cars and operators. The most casual observer will of course have noticed that the passenger lines connecting the business and residence portion of a great city are, during the morning and evening



hours, overcrowded, as a result of the incapacity of old methods for handling fluctuating traffic.

The fact that the steepest grades are as easily operated as levels is important, for the reason that it renders hill property, which is the most desirable for residence purposes, and which would otherwise be inaccessible, fully available. To the municipal statesman a matter of interest in this connection is the enormous increase in property values, resulting from even the projection of an enterprise of this nature in any direction, and which experience has proven always comes to stay, and is therefore followed by an increase in the tax duplicate of from 200 to 400 per cent.

The immense expense—from \$60,000 to \$210,000 per mile of double track—involved in the successful consummation of a cable railway enterprise lends tone to the undertaking which reveals itself in the improved character and cleanliness of the cars; and the substantial character of the work required results in an improvement in tracks—which altogether increases the comfort and pleasure of the passenger.

This method also removes the heretofore existing annoyance to those who are dependent upon horse propulsion for reaching their distant homes of being prevented from doing so by snow blockades; and is the only method of land travel in existence to-day that is entirely free from such exasperating occurrences.

It would be interesting to trace the benefits derived by various interests in the production of materials necessary for completing one of these great cable roads. It would take us to the lumber and mining camps, along the lines of railroads and canals to the iron furnaces, rolling mills and saw mills; from these again over other lines of transportation to the foundry, planing mill, machine shop, car shop, wire works; again, over other converging lines of travel to the city and final point of assembly, where employment is given to hundreds of laborers and skilled mechanics. The study of these hitherto undiscussed benefits, incident to the introduction of new methods, would show that immense benefits are derived by widely separated interests before the advantages with which the system is popularly credited are brought to light.

### British Tramways.

According to the House of Commons return, "of street and road tramways," authorized by Parliament, up to June 30th, 1886, there are 865 miles of street railways open "for the public conveyance of passengers" in the United Kingdom, comprising England and Wales, Scotland and Ireland. Some 221 miles thereof belong to "local authorities," that is, municipal or town councils, local boards of health, etc. The remainder (644 miles) belong "to other than local authorities," that is, stock companies. The total capital expended on account thereof is £12,573,041, or \$60,853,518. That includes "legal and parliamentary costs," \$2,718,885; cost of cars, \$2,808,454; horses, \$3,454,647; and locomotive engines, \$1,251,392. The number of horses "belonging to the companies" is 24,535; cars, 3,440; and locomotive engines, 452. The gross receipts for the year were (equivalent to) \$12,730,836; total working expenses amounted to \$9,784,331, leaving net receipts equal to \$2,946,505. The total "number of passengers conveyed, including season or composition ticket holders," during the year, was 384,157,524.

These totals are divided for the three parts of the United Kingdom as follows:

England and Wales has 706 miles of street railways open. Capital expended, £10,345,879 (\$50,074,054). The number of horses "belonging to the companies" is 19,388; cars, 2,772; and locomotive engines, 422. The gross receipts during the year were £2,110,918 (\$10,216,843); total working expenses, £1,639,390 (\$7,934,648); net receipts, £471,528 (\$2,282,196). Total number of passengers carried, 302,790,839.

Scotland has only 73 miles of street railways in operation. Capital expended, £1,157,559 (\$5,602,585). Number of horses, 349; cars, 384; locomotive engines, 17. Gross receipts, during the year, £335,900 (\$1,625,756); working expenses £243,693 (\$1,179,474); net receipts, £92,207 (\$446,282). Passengers carried, 59,528,415.

The statistics of street railways in Ireland are significant. The Green Isle has 86 miles open. Capital expended, £1,069,603 (\$5,176,879). Number of horses, 1,648; cars, 284; locomotive engines, 13. Gross receipts during the year, £183,520 (\$888,237); working expenses, £138,473; (\$670,209); net receipts, £45,047 (\$218,027). Passengers carried, 21,838,270.

The principal street railway operated by electricity is the Giant's Causeway, Portrush, and Bush Valley line, County Antrim, Ireland, which is fully six miles long. The capital expended thereon is £31,193; gross receipts, during the year, £2,086; working expenditure £1,970. The net receipts, therefore, only reached £116 (\$561). They only carried 49,645 passengers. Hitherto the expenses of this line, which belongs to the Premier Electric Tramway of the United Kingdom, have been "abnormally high, owing to the cost of coaching from Bushmills to the Causeway." The extension of the tramway to the Causeway is now completed. They have 5 electric cars, 9 carriages, 14 "good wagons," and 2 steam engines, according to Duncan's Tramway Manual. Where they use steam motors the cost per mile run has been equal to 29 cents (the receipts per mile run being 1s. 3¾d., or 33 cents), while the working expenses per mile run by electricity has not exceeded 3¾d.—barely 8 cents.

The only other line appearing to be run by electricity is the Blackpool Tramway (England), which is only two miles long. The capital expended thereon has been £12,370 by the town council (for construction and legal costs), and £18,141 by the lessees (for electrical machinery, cars, etc.), total £30,511, or \$147,673. Gross receipts for the nine or ten months it was in operation were £2,002; working expenditure, £1,647; leaving net receipts £355, or \$1,620. The estimated number of passengers carried is 240,000; they have ten cars. The line was worked by horses from September to December, 1885, and by electricity from December, 1885, to June, 1886.

It appears that the only cable tramway in operation in the United Kingdom is that on Highgate Hill, on the north side of London, belonging to the Steep Grade Tramways and Works Company, limited. The line is only 57 chains long, the gauge being 3 ft. 6 ins. The capital expended on this short cable line (barely three-fourths of a mile long) is £59,277 (\$286,901). They have ten cars, and carried 642,083 passengers during the year. Total receipts only amounted to £3,908 (\$18,915), while the year's expenditure reached £4,414 (\$21,364), thus involving a loss of £506 (\$2,449). The line was opened 30th May, 1884. For the year ending 30th June, 1885, they made a profit of £96 (\$465). It is now worked for the debenture holders.

Cable traction may become more popular in England in the near future, inasmuch as a line over 2½ miles long is to be constructed in Birmingham. "If, however, the workings of the new system prove satisfactory, a considerable extension will take place," says the *Pall Mall Gazette*. Two engineers, connected with the Central Tramways Company, visited the United States last summer, and gathered so much information that they now undertake to construct the Birmingham Cable Tramway so that it "will be a marked improvement upon the cable tramway on Highgate Hill, London." The latter, however, was built from designs prepared in San Francisco. The cost of construction of the cable road in Birmingham is to be £9,500, or \$45,980 per mile, which is half as much again as the construction cost per mile of the Mt. Adams and Eden Park Inclined (Cable) Railway, Cincinnati; that cost \$30,000 per mile. And the Birmingham cable line—from Colmore Row to Hockley, where there are no steep grades—is to cost \$46,000 per mile! The contract expensiveness thereof is enormous and unaccountable. It is as mysterious as the Birmingham *Daily Post* statements that "the financial conditions under which the work is to be undertaken have been the subject of prolonged negotiations between the directors of the Central Tramways Company and the municipal authorities," and that "the corporation will provide the stone-work, which will be supplied at cost price to the company."

*To be continued.*

## The Bentley - Knight Electric Railway System.

From the time that its first experiments in the transmission of electric power were made at Cleveland, in 1884, the Bentley-Knight Company's system has steadily grown in efficiency. For the past year its engineers have had the able assistance of the Rhode Island Locomotive Works, of Providence, R. I., in the perfection of mechanical details, and the fully equipped plant now running in Providence, exhibits a system in every way thoroughly complete.

In this and the following pages, we present the full detailed drawings of the city street railway system of the Bentley-Knight Electric Railway Company. The grant of a franchise to the North and East River Railway Company by the municipal authorities of New York City, to run a line of railway, built under these plans, across Fulton Street, and between Wall and Pavonia ferries, makes these drawings of great present interest.

It has always been the aim of Messrs. Bentley & Knight to perfect a street railway system absolutely adapted in every respect for use in paved and sewered streets, and in cities where the traffic requirements are heavy, and where the municipal authorities will not tolerate the use of overhead or surface conductors—the first by reason of its disfigurement of the streets, and the second on account of its danger and uncertainty of service.

The Bentley-Knight Electric Tramway plant consists of a stationary source of power, engines, boilers, and dynamo-electric machines, which may be located at an extreme end of the line, at tide-water, or at a railway station, wherever property or fuel is cheapest: a conduit running from the source of power to and along the whole length of the line, containing stationary and permanent conductors, which receive and distribute the electric current to the motors placed under the cars and geared to the axles; and a depending conductor which, passing through a slot in the conduit, and sliding in contact with the stationary conductors, maintains unbroken connection with the source of power. All the parts are of the most substantial and enduring character.

The direction and speed of the car are controlled at will by the driver from either end, the power consumed being always proportionate to the speed. Movement from rest to a speed of fifteen miles an hour in either direction is accomplished by the movement of a single lever. The driver can therefore proceed slowly, almost imperceptibly when required, and take any desired speed to recover lost time.

The conduit which contains and protects the electric conductors is kept perfectly clean by brooms attached to some of the cars. Snow and dust are swept into catchpits, located suitably with reference to street sewers. The facility and perfection with which the small conduit is kept clean commends the system to the approval of sanitary boards.

Each car is entirely independent of any other, and any car, generator, or engine may break down without interrupting the traffic. A car disabled through accident would be pushed to the depot by the succeeding one. An engine or dynamo may be cut out for any reason and at any time, by increasing the speed of others. The independence of the

motors and expansibility of the motor power renders the system wholly independent of horses or other reserve.

Cars may be stopped as quickly as desired, may reverse to avoid a block, and be replaced on the track (if derailed) by the motor without injury.

Powerful sweepers and snow-ploughs, driven by motors supplied from the same conductors, serve to keep the road in good condition during the heaviest winter storms. The same cars which run in city streets at from six to eight miles an hour, may be speeded to fifteen or twenty miles on suburban extensions, thus saving change of cars, and accomplishing rapid average time on long lines, or lines uniting villages or neighboring towns.

In applying the Bentley-Knight Electric System to a horse-road in operation, it is not required to suspend the traffic. A line may be extended at any time without difficulty.

The machinery on the car has no reciprocating parts; there is therefore no lateral hammering, the motion is smooth, and the wear and tear greatly reduced. The absence of machinery along the line requiring attention and oiling, and the automatic brushing of the track and conduit, contribute to diminish the cost of labor.

A fully equipped car, such as will be used on the North and East River Railway, is shown in side elevation and section in Figs. 1 and 2.

As will be seen by reference to Figs. 3 and 4, which show the truck in detail, side elevation and plan, the truck-frame is built on the regular locomotive pattern, of steel, forming a rigid connection throughout between the wheels. The motor, situated next to one pair of driving wheels, has a pair of pinions keyed to the ends of the armature shaft, which mesh with gears mounted on a crank-shaft in the center of the truck. Connecting rods on each side transmit the motion from the crank-shaft to the driving wheels. These, as shown, are set at a quadrant with each other so as to insure even running. The truck is built to a standard gauge of 4 feet 8½ inches, and has a wheel base of 6 feet, so that it can be used on curves with as small a radius as 45 feet.

In operation, the machinery is absolutely silent. All the electrical and mechanical details have been reduced to the utmost simplicity, so that the handling of cars can be entrusted to the most inexperienced. The motor on the car is of a modified Gramme type and wound in series, the regulation being effected by interposing resistances which are under easy control of the driver. It is proposed to carry a potential of 500 volts on the conductors, and according to grade and load, the current required will vary from 3 to 30 ampères. An ingenious device brought to the aid of the driver, is the arrangement by which, when the hand brakes are applied, the motor is automatically cut out of the circuit, and when they are released the motor is automatically thrown in, so that only a single operation is required to stop or start the car.

All parts have been built of exceptional strength; the motors especially being of a new and improved form, giving great durability and efficiency.

The conduit in which the conductors are carried forms a most important and interesting part of the system. In construction, the iron yokes are first set up and lined, being placed from 3 to 4 feet apart and between the ties which

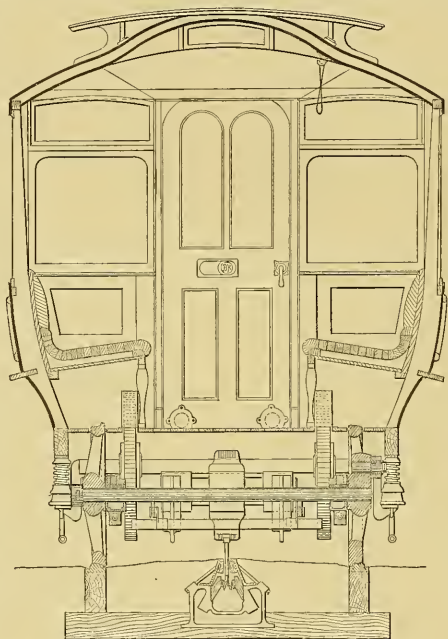

FIG. 1.—END VIEW OF CAR, SHOWING MOTOR, GEARING, CONNECTIONS, CONDUIT, CONDUCTORS, AND TRACK CONSTRUCTION.



support the rails. The continuous concrete gutter is then formed, the material being rammed around and between the yokes with the aid of wooden forms fitting the yokes. The insulating pins are then placed in the sockets cast in the yokes, and the conductors, in lengths of 30 feet, are set

current with but small loss of energy. These conductors are fastened to the side walls of the conduit on insulators of vulcanized wood dipped in white lead. The insulators are strongly set in sockets in the cast iron supporting yokes. Neither the traffic rails nor the conduit structure, form any

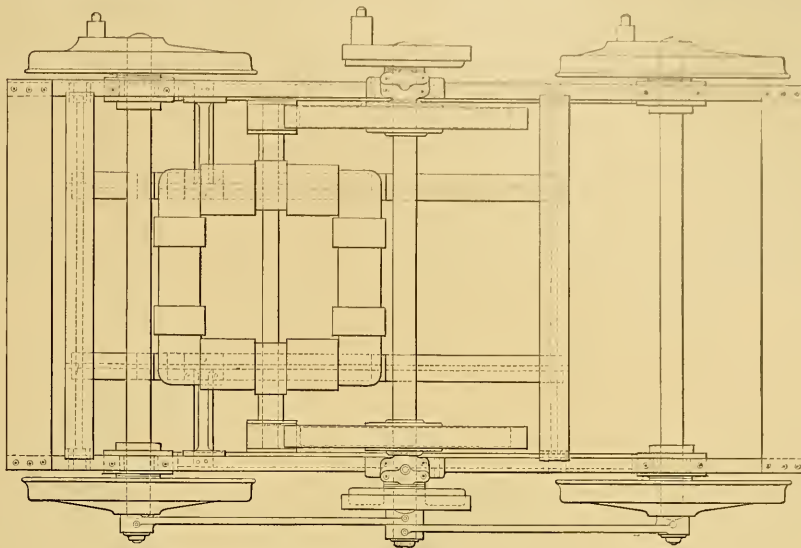

FIG. 3.—PLAN VIEW OF FULLY EQUIPPED MOTOR TRUCK. (*To be used with any variety of car body.*)

against the pins and firmly keyed to them. The electrical connections between the lengths of conductor are then made, and the slot irons set on the yokes, their stay bolts dropped into the exterior lugs of the yoke, and the slot irons

part of the electrical circuit. To provide for switching, a movable tongue is pivoted at the point of branching, so as to rest on the top of the conduit and to be readily set to close either of the branch slots and direct the contact plow

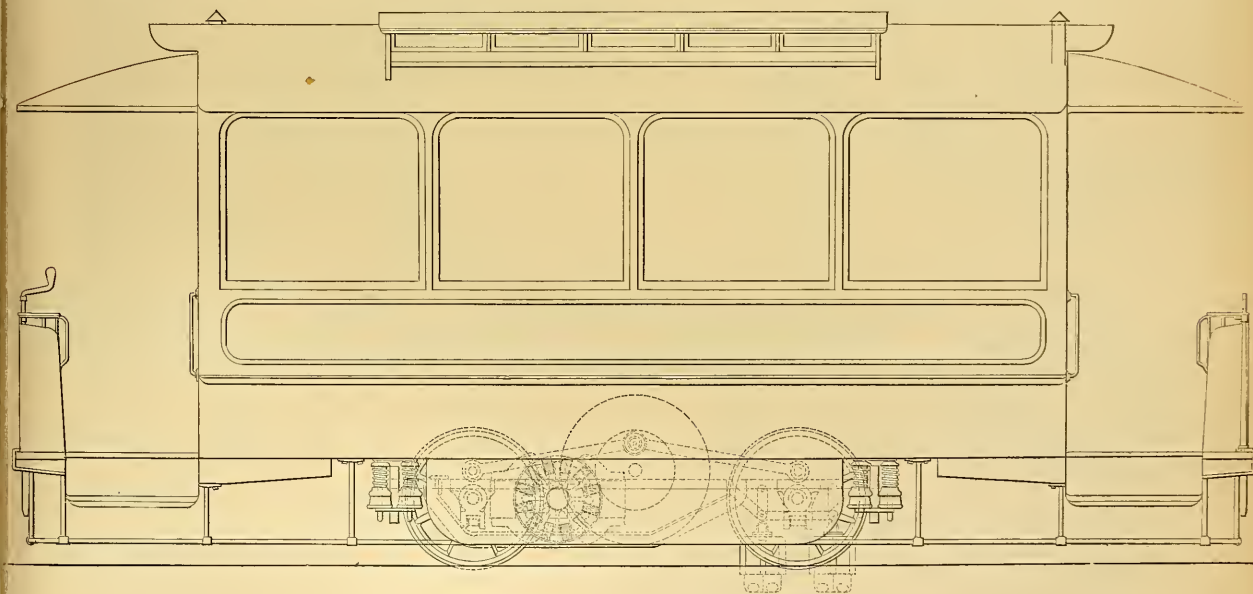

FIG. 2.—SIDE VIEW OF FULLY EQUIPPED CAR.

and yokes firmly bolted together, leaving a surface opening of only  $\frac{5}{8}$  of an inch. The two main conductors consist of channel-iron connected by expansion joints and lined with a continuous strip of copper of sufficient size to carry the

into the other. A corresponding conductor tongue within the conduit is moved at the same time. The bottom of the yoke extends only 1 foot 4 inches below the level of the pavement.

The method of making electrical connection between the motor and the conductors in the conduit—an important point—has been well worked out, and is clearly shown in Figs. 1, 2 and 5. For this purpose a contact-plow is employed which consists of a flat frame, I, hung from the car by transverse guides, on which it is free to slide the whole width of the car, and extending thence down through the slot of the conduit. It is provided with a swivel joint, Q, so as to adjust itself to all inequalities of road or conduit. This frame carries two flat steel insulated conductor cores,

readily renewed. Two plows are used on each contact for the sake of absolute reliability, and to prevent flashing at the contact.

Such are the main features of the system. Of its eminent practicability there should be no doubt. The question again is one of expense, and we therefore give transcripts of actual estimates submitted quite recently and now under consideration. The first is for the equipment of existing street railways in the city of New York, 3 miles, 1,440 feet, double track, minimum headway  $1\frac{1}{2}$  minutes,

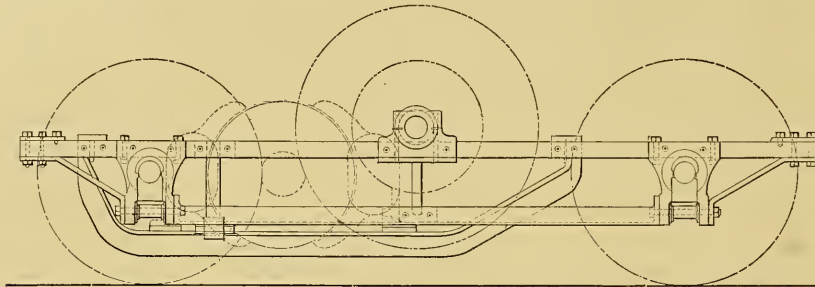

FIG. 4.—SIDE VIEW OF FULLY EQUIPPED MOTOR TRUCK. (To be used with any variety of car body.)

K, to the lower ends of which are attached by a spring hinge small contact shoes, H, of chilled cast iron, that slide along in contact with the two main conductors C. At the upper ends are attached flexible connections leading to the motor. This plow can be inserted or withdrawn through the slot at will, the spring hinge allowing the contact shoes to straighten out into line with the conductor cores when the plow is pulled upward and the shoes strike the insulating lining with which the slot irons are provided. By no accident, therefore, can anything be left behind in the con-

duit, to the lower ends of which are attached by a spring hinge small contact shoes, H, of chilled cast iron, that slide along in contact with the two main conductors C. At the upper ends are attached flexible connections leading to the motor. This plow can be inserted or withdrawn through the slot at will, the spring hinge allowing the contact shoes to straighten out into line with the conductor cores when the plow is pulled upward and the shoes strike the insulating lining with which the slot irons are provided. By no accident, therefore, can anything be left behind in the con-

average speed 7 miles per hour, running 24 hours per day, very heavy traffic, maximum grade 3 in 100.  
CONSTRUCTION AND EQUIPMENT.  
Conduit and conductors, 34,560 feet, at \$3, \$103,680; motor trucks, 37 at \$1,200, \$44,400; 50 h. p. dynamos, 12 at \$2,500, \$30,000; steam power plant complete, \$27,750; foundation, \$5,000; engineering, \$3,000; total, \$213,830.

ANNUAL EXPENSE.

Coal, 14 tons per day, at \$3, \$15,330; engineer and assistant, at \$2.50 and \$2 per day, \$1,642.50; firemen, 3 at

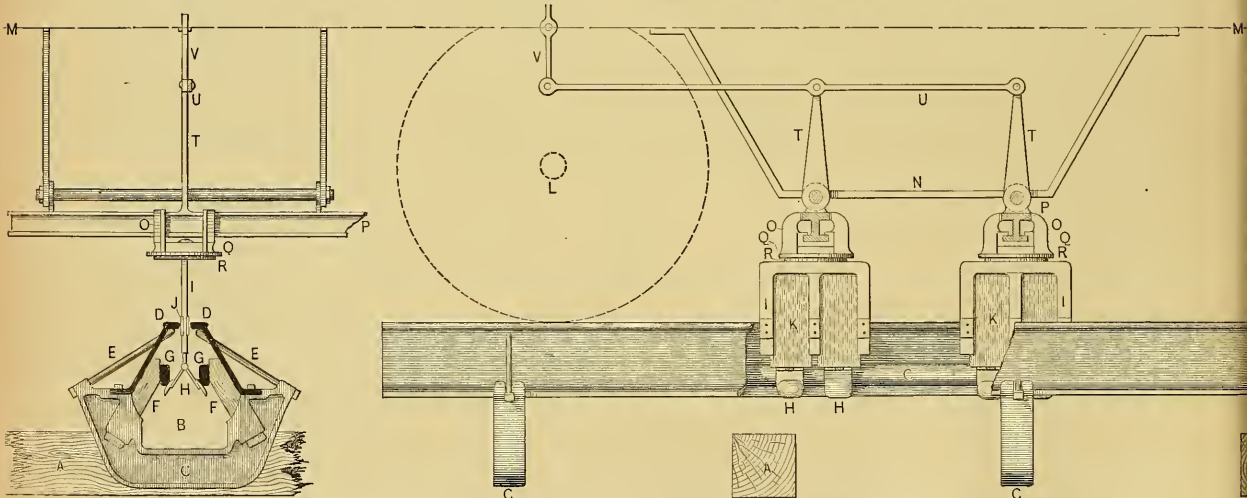

FIG. 5.—END AND SIDE VIEWS OF CONDUIT, ELECTRIC CONDUCTORS, AND CONNECTING PLOWS.  
(The continuous concrete bottom of the conduit is not shown in these plans.)

duit to obstruct succeeding cars. The plow guides are hung on transverse axes, and are held in a vertical position by a spring-catch that gives way when the plow meets an irresistible obstruction, and hence the plow is automatically thrown completely out of the conduit without injury, being also immediately replaceable. The contact shoes will stand weeks of wear, and cost next to nothing. The frame of the plow has wearing guards, I, of hardened steel wherever it can touch the edge of the conduit slot, and these are also

\$1.50 per day, \$1,642.50; machinists, 2 at \$2 per day, \$1,460; total running expenses, \$20,075. To which should be added interest on construction cost (\$213,830) at 6 per cent., \$12,829.80; and also depreciation of plant at 3 per cent., \$6,414.90; total expense and charges, \$39,319.70.

The second is for a down-town cross-town road in the city of New York, greatest grade 1 in 12, double track: 12,660 feet conduit (extra heavy), at \$4, \$50,640; 20 motor trucks complete, at \$1,200, \$24,000; six 50 h. p. dynamos,



at \$2,500, \$15,000; steam plant complete, \$20,000; foundation, \$2,000; engineering, \$2,500; total, \$114,140.

These actual estimates afford the best means for those interested to count the cost, and compare the expense of this admirable system with horse railways, cable roads, or locomotive lines in large cities—above ground. When we consider the advantages of the system for a street railway below the surface, its merits are greatly enhanced.

For suburban roads, or for lines in towns or villages, where the authorities will tolerate the use of exposed conductors, the Bentley-Knight Company will estimate to supply inexpensive elevated or surface conductors, and to furnish electric motors capable of running singly and of towing trains of two, three or more cars, as the traffic may require.

Full information, estimates, and drawings can always be obtained at the company's offices, No. 115 Broadway, New York City.

### The San Francisco Riots.

Our Special Correspondent says that on Sunday evening, Jan. 30, "the cowards" had the pleasure of seeing a Sutter street horse car running over a dynamite cartridge on Market street, when a terrific explosion took place, lifting the car two or three feet. That occurred about six o'clock. Shortly before eight, the same evening, another dynamite cartridge was run over. Fortunately none of the passengers were hurt. Our correspondent gives a sketch of the commencement of the "trouble," as follows: On the evening of Dec. 7, 1886, the employees of the Sutter Street Cable Railroad made an imperative demand that their pay should be increased, and their hours of labor shortened; and not receiving a favorable answer, the next morning they all refused to work, and for the next two days the company ran no cars, but on the 10th, they ran four cars with new men, and they soon increased the number. About a week after the Sutter Street men struck, the employees of the Geary

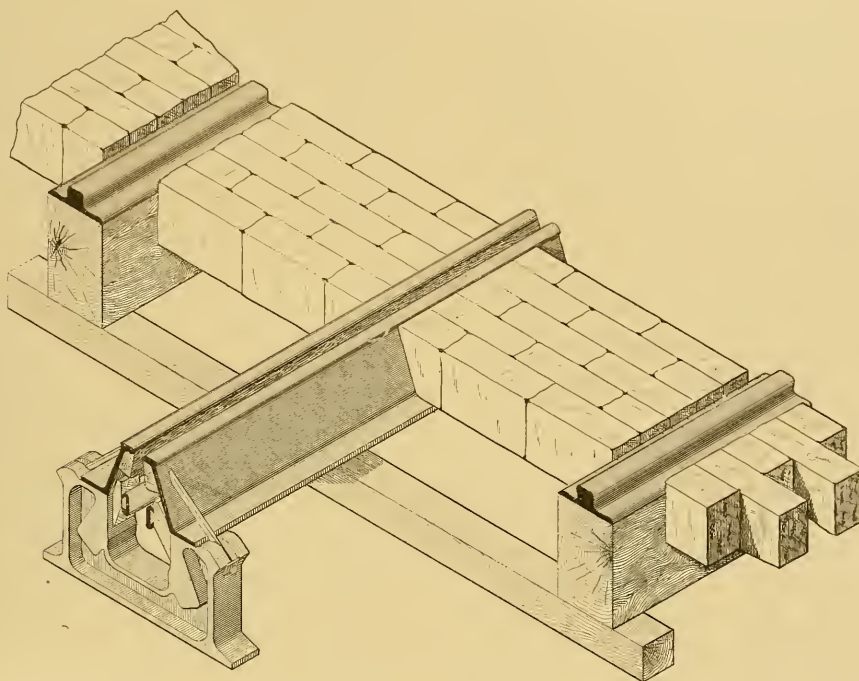

FIG. 6.—METHOD OF LAYING EXTRA HEAVY CONDUIT. STONE PAVEMENT.  
Opening at street surface only  $\frac{3}{8}$  inch. Extreme depth 16 inches; extreme width 20 inches.

### "A New Power."

Wonders never cease. We noticed recently that two inventors, hailing from Houston, Tex., Messrs. Barrett and Nelms—"the inventors of the new telephone lately tested between Galveston and New Orleans with marked success"—had proceeded to Washington, to procure patents for their telephone. More wonderful still was the statement that they had also "invented a new motor that will successfully operate and move street cars without the use of horse-power, water, fuel, or electricity; in fact, a new power." Six or seven weeks have elapsed since we read the glowing account thereof in the *Daily Picayune*, New Orleans. Ye wonderful inventors, let us hear from you; otherwise we may be tempted to ask, "Is it the Keely motor in disguise?"

A working man of Minerville, Pa., has patented a wonderful car brake; and it is reported that he has been offered \$75,000 for his invention.

Street Cable Road struck also—not on account of wages, or hours of labor, but out of sympathy for the Sutter Street men, and because they were ordered out by (as they told their superintendent) a higher power.

For a few days the strikers amused themselves by parading the streets over which the cars run on which they were formerly employed; they carried banners, etc., and were preceded by a fife and drum; and when they met a car, they commenced howling and yelling; and going from bad to worse, they took to throwing stones, beating and driving off the gripman and conductor, and causing the frightened passengers to leave the cars. Then they smashed fifteen or twenty cars. Early one very foggy morning they attacked a train on the hill, at Gough and Sutter streets, and, after beating and driving off the gripman and conductor, they smashed the headlight of the dummy, and, detaching the car, sent it down the hill. They also sent the dummy, without any headlight, down the hill in another direction, and it ran five blocks with tremendous velocity.

CHIPPEWA FALLS, Wis., obtained a franchise for a street railway, Feb. 9th.

JAMES M. McLAUGHLIN has purchased the Second street cable road, Los Angeles, Cal., everything, for about \$130,000.

THE JOHN STEPHENSON COMPANY, Ltd., New York, supplied the cars for the New Britain (Conn.) street railway.

THE WASHINGTON CABLE RAILWAY bill passed the House, and was sent to the Senate District Committee, Jan. 29. The company to undertake the work are to have authority to construct and lay down a single or double track railway, "with the necessary switches, turnouts and other mechanical devices, and sewer connections, necessary to operate the same by cable or electric power, in the District of Columbia," along certain avenues and streets, with the privilege of entering the Capitol grounds—under prescribed restrictions.

KANSAS CITY had its name up pretty high on telegraphic dispatches recently, through the issue of a warrant to apprehend Mr. W. J. Smith, president of the Ninth street cable line "for violating the ordinance requiring fenders to be placed on all cable cars." They were not put on, at first, because they were considered impracticable. The city officials, however, insisted upon having fenders on the cars. Attorney W. H. Lucas, interceded on behalf of President Smith, and whispered, rather loudly, that no Dutchman ought to hold office." He told Mayor Kumpf that the fenders could not be put on before they were made. The warrant was cancelled, and the fenders have since been attached to the cable cars.

STATE STREET, Chicago, is "a bone of contention," between promoters of elevated railways and property owners and the public. The Chicago Rapid Transit and Elevated Railroad Company have caused much amusement by informing a newspaper interviewer that they have the "L" road already on "a map in colors, showing an engine and three coaches as they will appear on the track, each coach having on its side the letters C. R. T. & E. R. R. Co."

FLOODS have recently turned some street railways into Venetian water-ways. The street cars running between Covington and Newport, Ky., were pulled through several inches of water, Feb. 4. The street cars were running through water between Dayton and Newport. At Cincinnati the street railways were inundated. The Third and Fourth street car lines were abandoned west of Carr street, and some of the passenger depots were cut off altogether. The Ohio river rose up to 56 ft. 11 inches.

FOG, if taken as a sign of civilization, places London, England, in the foremost rank. New York has been visited by a dense fog. On Feb. 8th, "street car drivers and elevated railroad engineers found themselves in one of the densest fogs that New York has had for years. The annoyance to river navigation could only be appreciated by those on the boats or along the river fronts. The shrieks of steam whistles, the tolling of bells, the groaning of fog horns were everywhere heard, and the irregular trips of ferry boats caused long lines of teams from the ferry gates up to the streets, excepting within close reach of the Brooklyn bridge."

A PATENT was issued, Jan. 25th, to Wm. C. Carrick, Philadelphia, for a tram-car motor—consisting of a gas engine, mounted on a suitable truck or dummy, with two friction drums, both journaled in fixed bearings; and a third friction drum to be thrown into, or out of, contact with either of the other drums, whereby motion is transmitted to the axle of the truck-wheels, in opposite directions.

THE new crossing for street railways, illustrated last month, is highly spoken of by those who have tried it; the foreign department is in charge of Mr. E. E. Russell Tratman, C. E., 144 Remsen street, Brooklyn, N. Y. Particulars may be obtained of Mr. Tratman, or of the inventor, Dr. W. T. Shannon, 94 Greene avenue, Brooklyn, N. Y.

## A Gas Motor for Street Railways.

A locomotive using gas for fuel has been in operation for several months on one of the street railways at Melbourne, Victoria (Australia), and has given great satisfaction. The gas is carried in four copper reservoirs, 6 feet long and 16 inches in diameter; they hold 280 cubic feet, the gas being compressed to about 15 atmospheres; this is sufficient for a run of 15 miles. The reservoirs are made for a pressure of 150 pounds per square inch, but the gas is usually compressed to about 100 pounds, as that gives ample power for one round trip of the engine and car. The reservoirs are recharged at the depot. The average daily consumption of gas for eight trips, or 40 miles, is 702 cubic feet. The locomotive weighs 10,080 pounds and the car 3,920 pounds. An "Otto" gas engine constitutes the motor.

## Obituary.

MR. JOHN D. HAINES is dead, and Newburgh (N. Y.) has had her street cars draped in black. The deceased gentleman was only 37 years of age. A short time ago, his son, aged 8, died. He leaves a widow and two sons, aged 11 and 5 years respectively. The deceased was a director of the Newburgh street railway, which was opened Dec. 23, as mentioned in January GAZETTE. He was also interested in several street railways constructed by the well-known firm of Haines Brothers, promoters of steam and street railways, 55 Broadway, New York, and his headquarters were alternately at New York and Sandy Hill. He was manager of the financial department of the Haines Brothers' firm. He also superintended road construction often, and could show the workmen how to handle a pick and shovel when necessary. He caught a severe cold while standing on the Newburgh street railway on an inclement December day, and a fatal attack of pleuro-pneumonia set in. When that line was opened, he sat up on his deathbed, which was by a window in the United States Hotel, whence he for a moment looked at the first street car that ran down town. Every effort was made to save his life, but he expired on the morning of January 25th, surrounded by several members of his family. He was buried at Cossackie Cemetery, the funeral services having been conducted by Rev. Arthur Jones, pastor of the First Baptist Church, Newburgh.

Mr. John D. Haines was a gentleman in the truest sense of the word. He was a man of integrity, natural ability, and good education. While filling the requirements of an active business life, he found time to be courteous, genial and kind-hearted. He has left a host of friends who deplore his early death. The surviving brothers are Messrs. Elmer T., David S., Charles D., and Andrew G. Haines. There is one sister.

## PERSONALS.

COL. J. W. HARTZELL, to whom the valuable franchise of a new street railway at Streator, Ill., was granted recently, has had great experience in building street car lines north and south, and is the man for the place.

MR. HENRY THOMPSON, who succeeded James W. Forshay as president of the Broadway and Seventh avenue Railroad Company of New York, is looked upon among surface railroad officers as the accredited representative in this city of William C. Whitney.

HANS S. BEATTIE, late Deputy County Clerk of New York was asked by a news gatherer what his name meant among the corporators of the Chambers Street Railroad. "I know nothing about it," was his answer. "I have too much to do in my official capacity to bother about railroads." The next day Mr. Beattie's nomination as Surveyor of the Port was announced. Not long afterward he sent an official communication as secretary of the Wall Street enterprise.

EX-SENATOR ALFRED WAGSTAFF, is the tallest railroad man living. He is the president of the Titan Society, New York. He made a dead set to get a railroad of his own device on Wall st., but it is said that the Philadelphians and politicians "took the wind out of his scheme."

MR. G. W. CARPENTER, superintendent of the Atchison (Kansas) street car lines, has resigned. He will be succeeded by Mr. Baldwin.



## POINTERS.

## ALABAMA.

*Anniston.* A street railway, to be operated by steam motors, has been decided upon.

*Birmingham.* Surveys are being made for a street railway, to be worked by electricity, to run from the city beyond North Birmingham (a distance of about three miles), where the promoters, Messrs. Smith and Eastman, have extensive property.

A declaration of incorporation of the Birmingham and Bessemer Railway Company was filed, Feb. 1st, with the Secretary of State, at Montgomery. The company, when organized, proposes to construct and operate a street railroad through the streets and suburbs of Birmingham. The capital stock will be \$100,000. The incorporators are Messrs. T. S. Smith, R. H. Haygood, William A. Walker, Jr., W. J. Miles and C. B. Powell.

The Birmingham & Jones Valley Street Railroad Company has been incorporated, and bids were received by Messrs. Heflin & Knox, up to January 31st, for the construction and equipment of a line six miles long; the line will probably be extended, ultimately, to Bessemer City, 12 miles distant; a bridge 700 feet long will cross the tracks of the Kansas City R. R., and the line will be laid with 45-pound steel rails and will be operated by steam engines.

The North Birmingham Street Railroad Company opened its subscription books on January 11th and the entire capital stock of \$65,000 was taken at once.

The Western Valley Street Railroad Company has been organized and will build a line  $2\frac{1}{2}$  or 3 miles long; it will be operated by horses. Capital, \$12,000. President, J. C. Westbrook; Secretary, W. H. Naff.

The city has now the following street railroads in operation: Birmingham & Pratt Mines, 7 miles; capital, \$35,000; Birmingham Street, 6 miles, \$27,000; Belt, 12 miles, \$200,000; Highland Avenue, 2 miles, \$10,000; total, 27 miles; capital, \$272,000.

*Huntsville.* The rails for the Huntsville Street Railroad have been delivered and work has commenced.

*Selma.* The Central City Street Railroad Company, capital stock \$40,000, has been incorporated to build the electric street railroad already mentioned. The incorporators are Sherrod H. Smith, Charles H. Lavender, Louis B. Joseph, John F. Brown and P. T. Vaughan.

The Selma Land Improvement & Furnace Company, which was incorporated January 21st to build a railroad, rolling-mill, etc., will construct an electric street railway among its various enterprises. Capital stock, \$3,000,000. R. M. Nelson, William Ullman, V. T. Vaughan, and others, incorporators.

*Sheffield.* The Sheffield & Tusculumbia Street Railroad Company has been organized with President, F. D. McMillan; Secretary, A. B. Almon; Treasurer, John H. Nathan.

## ARKANSAS.

*Texarkana.* The Texarkana Street Railway Company has been organized with president, N. W. Bechtel; secretary and treasurer, Thomas Orr; capital stock, \$10,000. The directors are Messrs. C. E. Mitchel, Thomas Orr, E. N. Maxwell, N. W. Bechtel and B. M. Foreman. President Bechtel called upon us end of January and said that work of construction will commence April 1st, and  $1\frac{1}{2}$  miles is to be finished by 1st of July—half thereof in Texas, and the other moiety in the State of Arkansas. Extensions to follow. The line is to be operated with mules. Fare 5 cents.

## CALIFORNIA.

*Anaheim.* Several lines of street railways are to be built by Anaheim and Los Angeles capitalists. The rails have been ordered and work will be commenced at once.

*San Diego.* The Henry Electric Railway Company, of Kansas City, have entered into a contract to equip a suburban railway, twenty miles in length. The dynamos are to be run by water power.

*San Jose.* A Daft electric railroad is talked of.

## FLORIDA.

*Pensacola.* The engineer of the new proprietors of the Pensacola Street Railway has been at work since middle of

January laying track from Palafox, on Government street, to Jaffray Bay. A further extension, making the navy yard one of its termini, is also contemplated.

## GEORGIA.

*Brunswick.* A street railroad company has been organized by C. P. Goodyear, W. E. Kay, and others; the general manager is W. Dart.

## ILLINOIS.

*Belleville.* The Belleville City Railroad Company, incorporated in 1867, proposes to build a line to East St. Louis, the road to be worked by steam motors, and every other train (hourly service) to run through between the two places without stopping. The distance is 14 miles. The road will be built soon.

*Chicago.* The Chicago Remunerating Elevated Railway Company have applied to the City Council for an ordinance authorizing them to construct elevated railways on about thirty streets. It is similar to the J. J. Richards ordinance, which was filed once before, and provides for six lines—distributed north, south, and west. The company offer to pay four per cent. of the gross receipts, if the sum is not more than \$350,000 a year, or \$6,000 annually for every mile of track used. The fare is to be five cents, or twenty-five rides for a dollar. The ordinance has been referred to the Law Department for an opinion as to the power of the Council to grant such a franchise.

The Chicago City Railway Company held their annual meeting, January 10th, when the following were elected directors for the ensuing year: S. B. Cobb, S. W. Allerton, D. K. Pearsons, C. L. Hutchinson, E. M. Phelps, D. G. Hamilton and C. B. Holmes. The Superintendent's report states that the number of passengers carried in 1886 exceeded those of 1885 by 4,750,000. The number of miles operated by cable cars was 6,074,500, and by horses 2,681,083. A simple arrangement for warming the cars has been devised whereby fresh air is introduced and sufficiently heated to make the cars comfortable and improve the ventilation. The air by this means is changed every two minutes and the temperature relieved of intense chilliness without being too warm. The expenditure for repairs has been \$69,351.97. The cost of handling snow was \$40,796. The track repairs expense has been \$31,942. Three miles of double-track cable railway from Thirty-ninth to Sixty-third street have been built. The company has also acquired the right to build a track on Fifty-first street from State street to Indiana avenue, making thereby an important connection with the Washington Park. There has recently been granted to the company a franchise for a cable railway on Cottage Grove avenue from Thirty-ninth street to Sixty-seventh street, and on Fifty-fifth street from Cottage Grove avenue to Jackson Park.

The Chicago City Railway Company have paid to the City Collector \$3,332, being the quarterly license fee due the city Feb. 1. The company certifies that during that period 318,835 trips were made, which average thirteen trips a day for 266.58 cars.

The North Chicago Street Railway Company have made considerable progress with their new cable road: Three miles of single track have been laid; and the material for two-thirds of the balance is already accumulated. The cable station, at Elm and Clark Streets, is about finished, and the engines are being placed in position. Work will be commenced on the tunnel about the first of April. It is expected that the road will be running sometime in the fall.

The Chicago West Division Railway Company elected the following directors, January 11th: B. H. Campbell, S. B. Cobb, W. H. Bradley, Jerome Beecher, W. H. Ryder, Henry Field and J. R. Jones.

There is a strong desire for the C. W. D. Ry. Co. to extend their Ogden avenue line beyond Douglas Park. Their charter authorizes them to run cars to Lawndale.

*Hyde Park.* The Hyde Park and Town of Lake Horse Railway Company seek the right to occupy Sixty-third street from State street to Stony Island avenue.

The Union Railway Company's ordinance was presented to Hyde Park Board of Trustees, January 10th, and referred to the Judiciary Committee. It gives the company the

right to lay down and operate two tracks on Forty-third street from the Illinois Central Railroad's right of way to the western limit of Hyde Park—State street—with the necessary turnouts and switches. The company agrees to begin work within two years from the date of the passage of the ordinance and will run its tracks over such viaducts as may be constructed. In the morning and evening the cars are to be run fifteen minutes apart and during the remainder of the day every half hour. The fare is to be five cents and the life of the charter twenty years.

*Lake View.* The Chicago Remunerating Elevated Railway Company are busy locating the line of the proposed "L" road through Lake View. Their preference is for Clark street, but in case they encounter too much opposition they will move farther west, run up Clybourn to Western avenue, then north on that street to Bowmansville, and thence to Evanston.

*Sreator.* Col. J. W. Hartzell, of Moline, has been granted the right to build and operate a street car line by the City Council of Sreator, Ill., the work to be commenced on or before August 1, 1887, and three miles laid by January 1, 1888. The franchise extends for twenty years, and is valuable.

#### INDIANA.

*Indianapolis.* The Mayor has appointed a committee to aid the project for a street railway to Crown Hill.

The Citizens Street Railroad Company has been authorized to build a line on South Meridian street.

*New Albany.* The project of building an inclined railway up the knobs from the foot of Spring street, and the instituting of a mammoth pleasure garden on the heights west of the city, is meeting with considerable favor among the capitalists of the city.

"A Chicago man has purchased the street railway of Richmond, Ind., thereby shutting out the Philadelphia capitalists. The absorption of the hitherto conceded rights of the Eastern men is becoming a favorite pastime of the residents of the breezy West."

#### IOWA.

*Fort Madison.* A company has been incorporated to build a cable railroad about three miles long.

#### KANSAS.

*Arkansas City.* "She needs a street railway for one and one-half miles on Summit street, and from the A. T. & S. F. depot to the Frisco," and we understand that all arrangements are made to secure it in the early spring.

*Atchison.* Mr. J. H. Beeson has been offered \$65,000 for the Atchison street railway.

*Clay Centre.* "Is resolved," says a correspondent "that when she makes arrangements for street transportation it will be in the nature of an elevated road, and there is a body of men now thinking seriously of undertaking the scheme. One end will be 'elevated' to the top of Quality Hill, the other 'lowered' to the warehouses, shops, factories, mills and wholesale houses in the third ward."

*Cottonwood Falls.* The board of the directors of the Consolidated Street Railway Company, met in the County Treasurer's office, Jan. 17. E. A. Hildebrand was elected President; W. P. Martin, Secretary; and J. M. Tuttle, Treasurer. W. P. Martin, J. W. McWilliams and W. H. Holsinger, were appointed a committee to prepare by-laws for the government of the company. C. J. Langtry and W. H. Holsinger were directed to have a preliminary survey made. The books are now open for subscriptions of stock.

*Detroit.* The Detroit City Railway Company has agreed to pay to the city as follows: For six years, from 1882 to 1887, inclusive, 1½ per cent of the company's gross receipts amounts to \$26,073. To this the company proposes to add \$3,133 back taxes on real estate, making a total of \$29,205. On this the railway company claims a credit of \$17,382 already paid in as percentage on receipts and \$10,340 paid as personal taxes under protest during the years 1882, '83 and '84, a total of \$27,722. This leaves the company still a balance of \$1,483 to pay to the city.

*Garden City.* The Garden City Street Railway has gone into the hands of a receiver. The trouble is over a claim

against the company for \$3,800 which they think is not just.

*McPherson.* The National Street Railway Company has been incorporated; the directors are, D. L. Whitzell, Theodore Boggs, T. J. Darrah, A. C. Wilcox, T. E. Barber, J. B. Darrah and O. E. Hudicker; capital stock \$40,000. Contracts have been made for three miles of road.

*Newton.* The Newton Street Railway ordinance was accepted Jan. 22d, and the work of constructing the line is progressing.

*Russell.* "A street car line is among the probabilities of the not distant future."

*Stafford.* The Stafford Horse Car Company has been incorporated, composed of John Clyne, Frank Cox and John Cothran, to whom right of way has been granted.

*Topeka.* The Junction City and Fort Riley Street Railway Company has been incorporated here.

The Topeka Rapid Transit Street Railway Company has received its ordinance from the city council to construct a street railway in the city. Said railway shall be operated on the route set forth either by cable, compressed air, electricity, soda motor, or such other motive power as will enable the company to run its cars with the same speed and safety as can be obtained by cable, subject to the approval of the city council. The company is also granted the right of way for the construction of branch lines for the period of twenty years, to be operated by horses or mules for the first three years. The tracks are to be laid on the established grade of the streets and avenues over which it passes. The cars shall be operated on routes set forth so that a car shall pass any given point every ten minutes during that part of the day which the road shall be operated, and the speed shall be at the rate of not more than eight nor less than six miles per hour. Cars shall be run not less than sixteen hours each day. The fare on said railway is not to exceed 5 cents from any point for a continuous passage to any other point. For children under 10 years, 3 cents, and children under 5 years, accompanied by parent or guardian, free. The company is allowed to charge double fare between the hours 10 p.m. and 6 a.m. Mr. J. B. Bartholomew, one of the incorporators, telephoned that nearly all of the material had been bargained for, that a portion of it has arrived, and active operations commenced. He said also that within twenty months the company would complete from six to ten miles of the road.

As soon as a new bridge is built across the river the line will be extended to Gordon street.

*Salina.* The city authorities have demanded \$25 a year per car, from the Salina Street Railway Company. They refused to pay, and the car drivers were arrested, but soon gave bail. Messrs. Ober, Teague and Seitz became "mule drivers" *ad interim*.

Andy Anderson has contracted to do the propelling of the street cars for the ensuing year. The price paid is \$1,080 per car per year. A third car will be put on the line soon, and in June it is the intention to put on a fourth car. The road will be extended to the Wesleyan University the coming season.

#### KENTUCKY.

*Lexington.* The Lexington City R.R. Co.'s car shed and stable, on Vine street, has been destroyed by fire, together with six cars which were in the shed. The fire originated in one of the cars, which had been run into the building, and it is supposed to have been caused by a lighted cigar stump being thrown into the straw in the bottom of the car by a passenger. Two barrels of coal oil in the room soon caught fire, and the entire building was almost instantly enveloped in flames. The loss is estimated at \$4,000, and is fully covered by insurance; \$1,200 being in the Continental of New York. We are informed that the company has now got clear of all its troubles (including a short strike), and the new cars are running prosperously.

#### LOUISIANA.

*New Orleans.* The New Orleans Telephone Company, John T. Hardie, I. E. Lyons and others, recently incorporated, are authorized to build electric railroads; capital stock \$200,000.



The New Orleans and Carrollton Railroad Co., held their annual meeting, January 10, and elected the following as directors for the current year: Messrs. J. Hernandez (President), H. Laroussini, A. M. Solari, B. T. Walshe, J. H. Menge, W. J. Behan, Chas. E. Black, P. Sala, and J. N. Avegno. Walter V. Crouch is Secretary.

The St. Charles Street Railroad Company (V. Riviere, Secretary) have declared a dividend of one and half per cent.

MAINE.

*Portland.* The Rico Electric Railroad Manufacturing Company, has been incorporated; capital stock, \$100,000; President, R. F. Straine, of Boston.

MASSACHUSETTS.

*Boston.* The Metropolitan R. R. Co. (President, C. A. Richards) held their annual meeting January 12th. During the year ending November 30th they received \$1,945,195 from passengers. Their net income was \$351,156. They paid a dividend of 8 per cent., leaving a surplus for the year of \$148,700. They have 85 miles of track, 687 cars, 3,543 horses, and carried (during the year) 39,582,061 passengers.

The Boston Consolidated Street Railway Company (being the Highland and Middlesex roads amalgamated) received (altogether) from passengers, during their past fiscal year, \$996,092. Their combined net income was \$188,977. The Consolidated has 41 miles of track, 349 cars, 1,747 horses, and carried 20,436,019 passengers during the whole year.

The South Boston Street Railway Company received from passengers, \$534,517. They have 13 miles of track, 199 cars, 903 horses, and carried 10,998,508 passengers.

The Lynn and Boston R. R. Co. received \$414,322 from passengers. Net income, \$45,887. Dividend, 8 per cent. Surplus for the year, \$2,350. This company operates 42 miles of track, have 175 cars, 748 horses, and carried 7,756,115 passengers.

The Cambridge Street Railway Co. received \$682,369 from passengers. Net income, \$115,013. Dividend, 5 per cent. Surplus for the year, \$5,845. They operate 41 miles of track, have 269 cars, 1,354 horses, and carried 12,631,641 passengers.

The Charles River Street R. R. Co. received \$133,234 from passengers. Deficit, \$3,876. The company has 12 miles of track, 58 cars, 325 horses, and carried 2,598,551 passengers.

Totals of the above companies :

	1886.	1885.
Capital stock	\$6,700,000	\$5,050,000
Gross debt	4,398,672	4,491,779
Earnings from passengers	4,795,720	4,303,809
Total income	4,858,655	4,408,509
Net income	815,163	714,967
Miles of track	236	229
Cars	1,737	1,716
Horses	8,620	8,374
Passengers carried	94,002,895	87,111,269

The Metropolitan R. R. Co.'s stables at Brooklyne, Boston, were burned Jan. 31st.

*Melrose.* The town has granted permission to the Stoneham Street Railroad Company to lay tracks through the town. The same company will also extend its tracks to Wakefield and Reading.

*Milton.* An elevated railroad to Boston, *via* Dorchester, is projected. Plans and estimates are being prepared.

*New Bedford.* The Supreme Court has dismissed the bill of the New Bedford and Fairhaven Street Railroad Company asking for an injunction to restrain the Acushnet Street Railroad Company from using the plaintiff company's tracks on William street, under authority from the Board of Aldermen. The judge decided that the aldermen had the power to authorize the defendant to use the plaintiff's tracks.

*Quincy.* A street railroad is to be built to several of the villages; five miles will be built at once, at a cost of about \$50,000. Mechanical traction is proposed. For particulars address Dr. W. L. Faxon, Superintendent of the National Sailors' Home; or John C. Randall.

*Springfield.* The directors of the Springfield Street Railroad Company have authorized the building of the Worthington street line. Extensions to Forest Park, Chicopee, Chicopee Falls, and other places, are in contemplation. John Olmsted has been re-elected president. The West Springfield line is not yet decided upon.

MICHIGAN.

*Ann Arbor.* The common council has not yet decided upon the scheme for an electric street railroad.

MINNESOTA.

*Minneapolis.* The Minneapolis street railway systems were sold, Feb. 1st, by President Thomas Lowry to a syndicate of eastern capitalists, represented by Lee, Higginson & Co., of Boston. The consideration was \$3,000,000. Five and one-half miles of track was added last year—making a total of 61 miles of street railway throughout the city. And among the improvements of last year were 314 horses, costing \$43,977.58; 40 Pullman cars, \$50,000.00; construction, \$69,613.15; new buildings, \$32,067.16. The number of men employed is 350. The number of horses (bought by the new company) is 773, with 226 mules. To feed these last year it took 2,209,600 lbs. oats; 2,200,000 lbs. ground feed; 258,000 lbs. bran; 333,200 lbs. corn; and 3,885,916 lbs. hay.

The council committee on railroads recently had a petition presented to it asking for a franchise for a new street railway company to run through the Seventh and Eighth wards. The question upon which the granting or refusal of the charter turns is, whether or no the Minneapolis Street Railroad Company's charter covers all districts added to the city after the charter was granted. No decision has as yet been reached.

MISSISSIPPI.

*Greenville.* The Greenville Street Railroad Company has organized as follows: T. L. Bates, President; R. B. Campbell, Vice-President; Geo. F. Archer, Treasurer; R. S. Toombs, Secretary; J. M. Jayne, Attorney; John Gunn, known as builder of the Compress, General Superintendent and Manager. \$20,000 has been subscribed; the iron has been purchased and work of construction is progressing. It is expected that cars will be running the beginning of May.

MISSOURI.

*Bangor.* A street railway is to be built here by F. M. Loughton and F. H. Clerque.

*Kansas City.* At the annual meeting of the Metropolitan Street Railway Co., the following directors were elected for the ensuing year: Col. C. F. Morse, A. W. Armour, Wallace Pratt, George H. Nettleton and Walton H. Holmes, of Kansas City; N. H. Emmons and C. E. Cotting, of Boston. This enterprising company is extending its cable lines as rapidly as possible. Twelfth Street is very narrow—only 30 feet—on which they have a right to lay a cable, and property owners are anxious for it to be widened.

The Inter-State elevated R. R. Co. contemplate a three miles extension to Quindaro. And a franchise has been granted for a cable extension of the elevated road from Riverview west to Powder Mills, a distance of a mile and a half.

The capital stock of the Grand Avenue Cable Company was recently increased from \$650,000 to \$1,500,000. The officers are Col. C. F. Morse, president; Walton Holmes, vice-president; J. T. Thornton, treasurer; Knight and Bon-tecuc, engineers. Much progress has already been made, and it is expected that the whole line will be completed by the end of 1887. There will be three cables running north, south and east. The Root grip is to be used, and the car (32 feet long) will consist of passenger coach and grip car combined, mounted on two trucks.

The Kansas City Cable Company now operate 3½ miles of double track—running 36,000 feet, or over seven miles of continuous cable—with two power horses. The company

has also two miles of double track (cable) reaching outside the city limits, almost completed—the contract calling for cars to be running by June 1st.

The Waldo Park Railway Company is incorporated by Eugene F. Hill, John A. McDonald, William M. Sloan, Hunter M. Meriwether and James Hayes—all of Kansas City. The road is to be in operation by June 1st. It will run through the eastern portion of the city, thence south to Waldo Park race track—total length ten miles. It will be used as a dummy line. This enterprise is entirely independent of the James A. Blair dummy line (which is to be in operation by June 15), and runs a mile east thereof.

The Henry Electric Railway Company, whose car house, etc., was burned by the explosion of a gasoline lamp, are reconstructing their premises, machinery and road, and repainting their cars.

A franchise for the Tenth Street cable line (which was before the Council a whole year) has at last been granted to B. F. Jones, Henry N. Smith, jr., and Henry B. Pain. The line is to run along Tenth St., to Brooklyn Ave., thence south.

A franchise has also been granted to T. J. Green, and others, for a horse car line on Prospect Ave., from Ninth Street to the southern limits of the city.

*Rosedale.* The Rosedale Street Railway Company has been incorporated. They seek a right of way from the state line to the western limits of Kansas City—so as to have a direct line from the city to this important suburb.

*St. Louis.* The mayor signed the bill on January 15th, authorizing the Missouri Street Railroad Company to change its motive power to cable or electric power.

The following lines have been authorized to change their motive power: Cass Avenue and Fair Grounds, Forest Park, Laclede Avenue and Fourth Street, Union, Southern, Citizen's, and the St. Louis and Lindell.

The St. Louis Bridge, Fair Ground and Forest Park Elevated Railroad Company state that their line will be of great advantage in opening up suburban real estate, and that, if the franchise is granted without delay, they will have trains running by October next. Mr. S. Cupples is interested.

A large model, 200 feet long, of the Terry system of cable railroad, including curves, automatic switches, and crossings, has been exhibited by the inventor. The work has been done under the supervision of a syndicate appointed to investigate the matter, and the system will probably be laid down on one of the city lines.

The Union Street Railroad Company is experimenting with a new heater.

#### NEW JERSEY.

*Orange.* The Daft Electric Company has been awarded the contract for the electric railroad.

*Passaic.* A street railroad is to be built the ensuing spring; it will be operated by horses.

#### NEW YORK.

*Brooklyn.* The Long Island Elevated Railroad Company was incorporated several months ago, its stock being equally divided between the Long Island and Atlantic Avenue Railroad companies; and their petition for a franchise to construct an elevated road on Atlantic avenue has been in the hands of the Brooklyn aldermen a considerable time—and in our issue for August it was pointed out that "It is not expected that the aldermen will act on the application until after their summer vacation." A petition with about a thousand signatures (including that of ex-Judge Jasper W. Gilbert and many other prominent citizens) was presented to the aldermen January 24, asking that permission be granted to construct the said elevated road, "so that the steam railroad can be removed from the surface." This was referred to the Railroad Committee, who have also had the company's application under consideration a long time.

The Union Elevated Railroad Company, since our last issue, have obtained their permit from the Department of City Works, and the work of construction is progressing rapidly—commenced, January 8, at the junction of Hudson and Flatbush avenues and Fulton street.

The Atlantic Avenue Railroad Company proposes to build a cable road on Fifth avenue. The Hicks Street line is to be built this spring. The cable road on Park avenue is nearly completed, and will be opened shortly. The company has increased its capital stock from \$700,000 to \$1,000,000.

*Lockport.* The street railroad was opened on January 1st, and is considered a great improvement to the city. It was constructed last year under the supervision of Mr. T. W. Harris.

*New York.* The 17 surface street railways of this city carried 210,032,484 passengers during their last fiscal year, being 18,712,961 more than in 1885. The elevated railways carried 115,109,591 passengers last year, being an increase of 11,396,862 over 1885. On the Third avenue surface road, which was most severely attacked by the strikers, there was a falling off of 4,250,000. On its next neighbor—Fourth avenue line—there was an increase of 3,134,466. The greatest gain was 10,746,370 passengers on the Broadway and Seventh avenue line. The total expenses (including taxes) of the Third avenue surface road, which carried 27,750,000 during the year, was \$1,092,106.58; that is, 3.93 cents (nearly 4 cents) for each passenger carried. The cost per passenger on the other principal lines was: Broadway and Seventh avenue, 3.52 cents; Second avenue, 3.44 cents; Sixth avenue, 3.54 cents; and on Eighth avenue, 3.75 cents.

The New York Underground Railway Company, it is announced, has signed a contract with the United States Subway Company to build an underground railway from the City Hall to Harlem, partly under Broadway and partly under Madison avenue and other streets. Col. Hazard, president of the Subway company, says the company has \$3,000,000 to back it, and will go right along. Edward Lawterbach is president of the underground company.

The Port Chester and Rye Beach Street Railway Company, of New York City, has been incorporated. Capital stock, \$50,000. Charles D. Haines, 8 East Twenty-fourth street; George W. Blanchard, George W. Stetson, Andrew G. Haines, Frank W. Stanley, New York City; Maurice Dillon, Port Chester, and Frank H. Skeele, Brooklyn, incorporators.

*Saratoga.* The Saratoga Street Railway Company has been incorporated. Capital stock, \$50,000. Malcom Peters, Myron L. Derick, Brockton, Mass.; Geo. S. Batcheller, Henry Smith and others, Saratoga Springs, incorporators.

*Saratoga Springs.* A street railroad, to be operated by horses, is projected, south from Excelsior Springs, with branches eastward, and connecting by Nelson street, forming a belt line.

*Schenectady.* The street railroad company has been refused permission to lay its tracks over the State street bridge, owing to the unsafe condition of the structure.

*Syracuse.* The Burnet Street Car Company, which is to run a line to East Syracuse, must, according to the terms of the franchise, have its tracks laid this month. It is understood that the directors will accept the terms of the old Fourth Ward Railroad Company to run over their tracks from Catherine street to the terminus in the central part of the city. The terms are \$1,200 a year. This was thought to be exorbitant at first, but the new company will probably submit, with a view of eventually buying up the old company's tracks in the Fourth ward, which have been offered at a reasonable figure.

*Utica.* The Oneida Street Railroad Company, of Utica, has been incorporated. Capital stock, \$40,000. Wm. C. Wilcox, Henry Ney, Thomas J. Griffith, Henry M. Ney, Frank J. Cronk, Utica; Daniel L. Jones, Jr., and Isaac D. Reynolds, Brooklyn, incorporators.

*Yonkers.* A street railroad is projected through Port Chester to Rye, and Rye Beach, in Westchester county. It only remains to get the consent of the town authorities at Rye.

#### NORTH CAROLINA.

*Durham.* A street railroad company has been organized with a capital stock of \$10,000. President, W. F. Blackwell; Vice-President, J. S. Carr; Secretary, J. R. Blackwell.



*Henderson.* The Henderson Street Railroad Company is to be incorporated.

## OHIO.

*Cincinnati.* The Mount Auburn Cable Railroad Company has awarded the contract for the cable to Broderick & Bascom of St. Louis. It will be a wire cable  $1\frac{1}{2}$  inch thick, eight miles long, and weighing about 52 tons.

A cable railroad is to be built at once from this city to Hamilton; it will be in operation next summer. Address S. Miner, Chairman of the Fairmount Improvement Association, Cincinnati.

The Cincinnati, Norwood and Pleasant Ridge Passenger Railroad Company has been incorporated by Louis Kennedy and others; capital stock, \$100,000.

The Board of Public Affairs walled over the route of the proposed cable railroad on Vine street to Corrysville, on January 12, considerable excavation and grading will be needed.

The Mt. Adams and Eden Park Inclined Cable Railway Company, which has four miles of double track, has the following estimate of cost: Eight miles of track, with wheel vaults, \$309,964; machinery, \$27,764; engine-house, \$22,432; equipment, 20 new cars and cables, \$45,217; carhouse and lot, \$17,795; engine to be added, \$5,500; total, \$428,626. President Kerper estimates 5,000,000 passengers for the current year, yielding a net income over all fixed charges of over six per cent on the capital stock.

*Steubenville.* Andrew G. Haines, of Haines Brothers, New York City, has applied to the city council for a franchise and right of way for a street railway. The road would extend from Mingo street, along the county road, Third, Market and Fourth streets, and Franklin avenue to Riverside blast furnace, over three miles. Work to be commenced this season.

*Zanesville.* The Main Street and West Side Street Railway Company has been incorporated, with a capital stock of \$25,000; Francis M. Townsend, Thomas W. Lewis, William C. Townsend, Rufus C. Burton and H. B. Parsons, incorporators.

## PENNSYLVANIA.

*Allegheny.* The Allegheny Rapid Transit Passenger Railway Company has been incorporated, capital stock, \$50,000. President, J. W. Benn; Directors, E. A. Knox, A. L. Clark, Max Scheider, Lewis Brandt and J. M. Sweanger. The road will be two and a half miles long. Horses to be used. The council reserves the power to purchase the road at the expiration of 20 years. The company agrees to build the road to Jackson street in six months, and to have it completed in two years.

*Carbondale.* A project is on foot to build an electric street railway. For further information address J. W. Aitken.

*Philadelphia.* The Commonwealth will back the application of the Twelfth and Sixteenth Streets Passenger Railroad Company for the right to lay its tracks across those of the Philadelphia, Wilmington and Baltimore R. R., at Washington avenue and Sixteenth street. The original application was made in 1885. The railroad company claims that this is a very dangerous point for crossing.

There are  $85\frac{1}{2}$  miles of surface street railways, and  $2\frac{1}{2}$  miles of elevated railways, within the city limits; some of the lines extend considerable distances beyond. The total license fees for street cars, for the current year is \$46,550. For each two-horse car a fee of \$50 has to be paid the city yearly. 928 cars are licensed, double fees being paid for those using the bridges.

The Frankfort & Southwark R.R. Co.'s annual report shows: Receipts, \$620,509.02; expenditures, \$408,562.10; passengers carried during the year, 11,014,359, an increase over 1885 of 824,158. Included in the expenses were \$25,812.72, paid for repairs to streets, and \$32,881.98 taxes paid to the city and state. President, John Noblit; directors, Alfred Smith, Edward S. Handy, Daniel Haddock, Jr., Thomas McClary, Charles S. Lincoln, Jeremiah J. Sullivan, Edgar Fries, James H. Gay, M. W. Lipper, John L. Lawson, David Fleming, Horace Geiger.

The Ridge Ave. R.R. Co., have elected for president

E. B. Edwards; vice-president, John Lambert; secretary and treasurer, William S. Blight; directors, Charles Thompson Jones, Henry Morris, William T. Carter, W. S. Grant, R. A. F. Penrose. Total receipts, \$350,176.15; spent on repairs to roads, \$7,319.71; taxes, \$24,630.60.

Presidents and directors of other lines are: *Citizens'*—President, John McCarthy; directors, Charles E. Ellis, John H. McIlwain, Charles T. Colladay, Richard M. Hartley. *Continental.*—President, W. L. Elkins; directors, P. A. B. Widener, Clay Kemble, G. W. Elkins, William J. Elliott, George D. Widener. *Empire.*—James McManes, Frank H. Ellis, Collins W. Walton, John H. McCarthy, William H. Kemble, P. A. B. Widener. *Hestonville, Mantua and Fairmount.*—President, Charles H. Lafferty; directors, John Keller, Levi N. Wagner, John R. Griffith Harry Donohue, Daniel Glacken. *Philadelphia and Darby.*—President, Beauveau Borie; directors, M. Hall Stanton, Collins W. Walton, William W. Colket, Thomas W. Walker, C. W. Kunkle, Charles J. Walton. *Philadelphia.*—President, William W. Colket; directors, W. S. Wilson, William Cochran, John M. Chestnut, John Markoe, Collins W. Walton, John A. Brown, Jr. *Second and Third Streets.*—President Alexander M. Fox; directors, William Anspach, Andrew J. Holman, William Eisenbrey, M. Hall Stanton, E. T. Eisenbrey, A. L. Crawford, J. R. Whittaker, James A. Freeman, Horace T. Potts, George Hoff, William Dulles, James McManes. *Thirteenth and Fifteenth.*—Pres. Thomas W. Ackley; directors, Thos. Cresswell, B. S. Kunkle, George W. Hall, William R. Warner, John C. Bingham. The annual report stated gross receipts \$372,411. The sum of \$100,000 was declared in dividends.

*Union.*—President, William H. Kemble; vice-president, P. A. B. Widener; directors, James McManes, William L. Elkins, Henry Bumm, William S. Stokley, Matthew S. Quay.

The Philadelphia Locomotive Vehicle and Stationary Motor Company has been incorporated; capital stock, \$1,250,000.

The Philadelphia Traction Company will substitute passes in book form, with coupons attached, for the annual pass tickets. This is owing to the abuse of the slip system.

*Scranton.* The Nay Ang Cross-Town Street Railroad Co., has been incorporated. It will run from Scranton to Dunmore, and will be an electric railroad. President, G. Clark; Treasurer, B. E. Leonard; Secretary, T. C. Snover. Capital stock, \$50,000.

The Van Depece electric railways are giving great satisfaction. Other similar lines are projected. The mayor specially alluded to the success of the Scranton Suburban Electric Railroad in his annual address.

A company, of which E. B. Sturgis is president, will build an electric railway in Scranton, it is announced.

## TENNESSEE.

*Bristol.* A street railroad company has been organized by W. A. Sparger, N. M. Taylor, A. D. Reynolds, and others.

*Columbia.* The survey is being made for the Columbia Street Railroad.

*Memphis.* The Union Street Railroad Company is the title of the company formed by the consolidation of the Memphis City Street Railroad Company and the Citizens' Street Railroad Company. The capital stock is \$1,000,000. President, Napoleon Hill; Vice-President, and General Manager, Thomas Barret. The street railroad system will be extended and the old tracks relaid.

The Memphis, Greenwood and Prospect Park Railroad Company has been incorporated by T. J. Latham, R. W. McLester, John D. Adams, Avery Lamb, S. H. Lamb and others. The line will be operated by steam motors, and the maximum fare is set at 10 cents.

*Nashville.* The Nashville Cable Railway Company has been incorporated to build a road three miles long; capital stock, \$300,000; E. T. Noel, George K. Whitworth, George Davison, T. B. Fite and Henry B. Morrow, incorporators.

The Nashville, Vanderbilt and Belmont Avenue Street Railway Company has been incorporated by Duncan Eve, S. Hill, R. M. Samuel, H. G. Gwyn, G. W. Thompson and W. L. Horn. Horse, cable or any other power may be

used. Horses will be used, and possibly steam motors on the Cedar street grade.

The Sumner Street Cable Railroad Company has been incorporated by E. T. Noel, George K. Whitworth, George Davison, T. B. Fite and Henry Morrow.

*Rockwood.* A street railroad is to be built.

#### WASHINGTON TERRITORY.

*Spokane Falls.* The Spokane Street Railway Company has been incorporated. W. J. Brown, president; A. J. Ross, vice-president and general manager; H. C. Marshall, secretary and treasurer. Two and one-half miles of track is to be laid, with 30-lbs. rail. Five cars are contracted for; and work will begin as soon as the frost is out of the ground.

#### WEST VIRGINIA.

*Charleston.* A street railway is projected.

#### WISCONSIN.

*Hurley.* The Gogebic Street Railroad Company has been incorporated by C. F. Dunbar and others. Capital stock, \$25,000.

### New Books, Pamphlets, etc.

*The Electric Motor and its Applications.* We return thanks to Mr. W. A. Kreidler, 44 Lakeside Building, Chicago—Western Manager of *The Electrical World*—for copies of Messrs. Martin and Wetzler's valuable book. "No department of applied electricity has undergone greater development during the last two years than that which concerns the use of electricity as a motive power." After explaining the generation of the electric current and its conversion into a power of propulsion, an interesting history is given (with illustrated descriptions) of early motors and experiments in Europe and America. Dr. Antonio Pacinotti was the first to describe (in 1864) the now "well-known principle of the reversibility of the dynamo-electric machine, the practical utilization of which implies the development of a new electrical industry—the electrical transmission of mechanical energy." The Sprague, Bentley-Knight, Van Depoele, Daft, Julien, Edison, Henry, and other street railway motors are described and illustrated. History, description and illustrations are given of electric railways at Baltimore, Chicago, Cleveland, Coney Island, Menlo Park, Minneapolis, Montgomery (Ala.), New Orleans, New York, and Philadelphia; Toronto and Windsor, Canada; Antwerp, Berlin, Besspool, Blackpool, Breuil-en-Auge, Brighton, Brussels, Charlottenburg, Drybrook Mine, Dusseldorf, Frankfort, Hamburg, Lartigue, Lichtenfelde, London, Paris, Portrush (Ireland), Vienna, and Zankeroda Mines (Saxony). Some of these were only exhibition railways—constructed for exhibition purposes. In a word *The Electric Motor and its Applications* comprises all the information that has yet seen the light of publicity regarding the application of electricity to run passenger cars, etc., and it is a book that should be closely studied by all interested in electric railways—practically or historically, or simply for amusement—if they would keep abreast of the times. New York. W. J. Johnston, publisher, 168-177 Potter Building.

*Duncan's Tramway Manual.* We are indebted to Mr. J. H. Duncan, F. C. A., Secretary of the Tramway Institute of Great Britain and Ireland, for a copy of Mr. Wm. Wallace Duncan's Manual (for 1886) which contains statistics showing the growth of tramway (*i. e.* street railway) enterprise during the past year, which, however, "has not been so important as in previous years. The reason for this is probably due to the investing public having been discouraged by the notorious manner in which some of the more recent steam tramways have been overburdened with capital by their promoters." In his preface to this 9th edition (April, 1886), Mr. Duncan says, "Experiments of various electric and compressed air motors continue to be made, but so far have failed to prove that they can in practice compete with horse and steam power." The Manual gives "Abstracts of accounts and traffic returns" of all the British and Irish street railways, as well as several foreign tramways—on the eastern side of the Atlantic ocean. The street railways of the United States are left out altogether. The tramway tables, at the end of the book, comprise much in-

formation in small compass. And the directory gives names, addresses, and descriptions of street railway officials.

*Street Railway Association of the State of New York.* We have received copies of the first three reports of this association from the Secretary, Mr. Wm. J. Richardson. The association of the Empire State was organized December 20th, 1883. And these reports are valuable contributions to street railway literature, and of much interest beyond New York State.

*Taxation of Street-Railroad Property.* This pamphlet was duly received. We can not do justice to the argument by extracts, and would recommend those interested in the question to procure a copy. It is an interesting and edifying "argument" on "State taxation of corporate property," delivered before state convention last September, by the Hon. G. Hilton Scribner, president of the Central Park, North and East River R. R. Co. New York City.

*Van Depoele Electric Railways.* A history of the Van Depoele system has been issued in a 40 page pamphlet, with numerous illustrations. "Street railways and tramways \* \* \* have now become a necessity in all cities. \* \* \* Various modes of propulsion of cars have been tried. \* \* \* The propulsion of cars by electricity has come to us at the right time." It occurred to Mr. Charles J. Van Depoele as far back as 1874, while engaged in Detroit, experimenting with electric generators, motors, etc., that trains of cars, and even ordinary street cars could be run by electricity. And the new pamphlet before us states what this diligent inventor has done since, and where the Van Depoele electric railways are to be seen in practical operation. Chicago: Van Depoele Electric Mfg. Co., 15-21 N. Clinton St.

The Chicago, Burlington & Quincy R. R. Co. has published a Pronouncing Dictionary containing 320 pages, 32,000 words, and 670 engravings. It teaches everybody how to pronounce correctly. Send sixteen cents in stamps to PAUL MORTON, G. P. and T. A., C. B. & Q. R. R., Chicago, Ill., and get a copy of the Dictionary—the cheapest book issued.

*Grosse Berliner Pferde-Eisenbahn Actien-Gesellschaft.* We have received a copy of the last report hitherto issued (that for 1885) of the Grand Berlin Horse Railway Company, from which it appears that 77,350,000 passengers were carried in 1885, being an increase of 6,550,000 (or 9.25 per cent.) over the previous year. The earnings for 1885 amounted to 9,391,774.76 marks (\$2,254,026), being an increase of 680,788.88 marks, or \$163,389 (that is 7.8 per cent.) over 1884, and a dividend of eleven per cent. was paid. The track (single and double) extends to 172,780.77 kilometers (107,357½ miles). The company has 2,160 employees, 3,111 horses, and 612 cars. Capital stock, 27,100,000 marks (\$6,504,000). These lines were opened for business July 8, 1873.

*Kalender für Eisenbahn-Techniker.* The Calendar for Railway Technicians (1886), for which we return thanks to the directors of the Grand Berlin Horse Railway Co., contains tables of statistics of street railways (Strassenbahnen) "in Deutschland, Oesterreich, in den Niederlanden und der Schweiz," giving the name, length of track, chief manager, date when opened, and amount of capital of each company. There are fifty street railway companies in Germany, twelve in Austria, fourteen in the Netherlands, and four in Switzerland.

THE "Pioneer" Catalogue. The Lewis and Fowle Manufacturing Co. (of 27 to 35 Walworth, and 32 to 40 Sandford Sts., Brooklyn, N. Y.) preface their "first complete catalogue" of street railway supplies by saying, "We manufacture and supply every article required in the construction, equipment, and maintenance of a street railway." The book comprises 128 pages, 13½x10, full of illustrations—from cars and tools, down to conductors' caps and buttons.

### Business Notes.

THE JOHN STEPHENSON COMPANY, Limited, 47 East 27 street New York, who have been diligently manufacturing street cars and omnibuses since 1831,—and who (in 1859) built the first street car run on a London tram-



# The Street Railway Gazette.

VOL. II.

CHICAGO

MARCH, 1887.

NEW YORK

No. 3

## Construction, Equipment and Maintenance of American Street Railways.

BY AUGUSTINE W. WRIGHT.

*Continued from page 23.*

Mr. Charles Frick, of the North Baltimore Passenger Railway Company, wrote to me :

very little, as we have used the present arrangement as far back as I can remember.

"Galled necks. We use no *poles* winter or summer, so this will not apply to our horses.

"*Springs* are of vital importance, but it is immaterial whether they are put *in the drawhead*, or in the *tugs*. The horse derives the same advantage in either case, with an equal compression of spring.

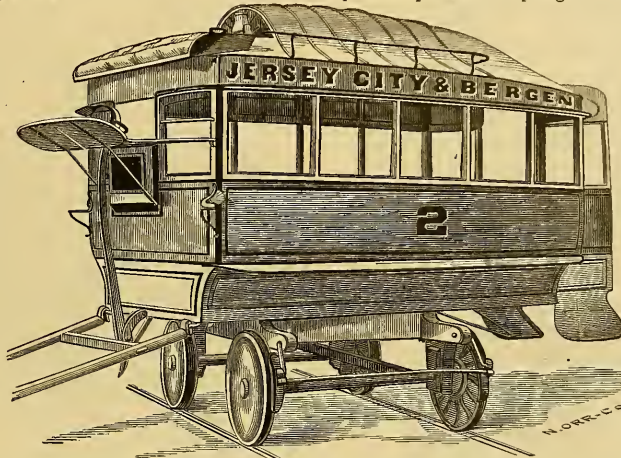

FIG. 44.

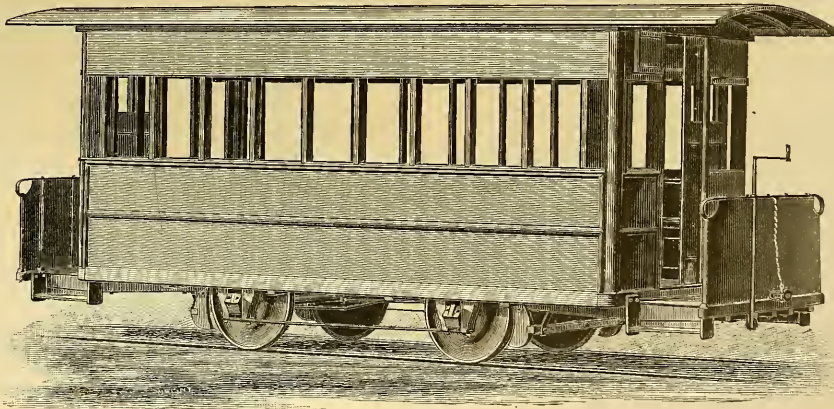

FIG. 42.

"I have often noticed in other cities how low the horses are attached to the cars, and have wondered why they were not elevated, as with us. We find our arrangement works very satisfactorily, but as to saving in horse flesh, I can say

"I therefore see no reason to change my opinion that 30 inches is a better height than 25 or 26 at which to attach the animal to the car.

"Should any difficulty be experienced from the collar







It was then first class, and is introduced to show the advance in construction from that date to the present, as evinced in Fig. 43, which shows North Chicago City Ry. car No. 250. This car was exhibited at the exposition of railway appliances in Chicago, and is in regular service upon the North Chicago City Railway.

Fig. 44 shows a car built in 1853, for the Jersey City & Bergen Ry. Co. It was operated with one horse and turned upon its truck, thus doing away with turn-table or switch at either terminus. The driver was elevated, as upon an omnibus.

Fig. 45 shows a car built in 1860, for New Orleans, with an enclosed front platform, this end always being the front.

Fig. 46 shows a small open car built in 1874 with enclosed front platform, and passengers seated to face each other, on the sides, as in box cars.

Fig. 47 shows an open car built in 1876, with reversible seats, and sash at each end, life guards before the wheels, trussed body, etc.

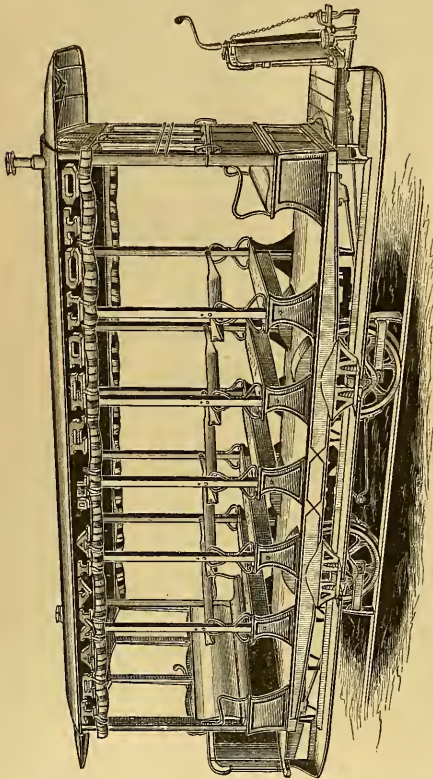

FIG. 47.

Fig. 48 shows an open car with reversible stick back seats (thirty-five passengers), ventilators in roof, etc., built in 1881.

Fig. 49 shows an open car built in 1882, containing a central passage way, the passengers entering and leaving the car via the platforms. It has sashes at either end.

Fig. 50 shows a car built in 1884, which also has side steps, so that passengers can enter or leave the car at either side or either end.

In answer to my question "What do you claim as peculiar excellences in your car?" Mr. Stephenson replied:

- "1st, elegance, including ornamentation.
- "2nd, lightness in weight and movements.
- "3rd, strength and durability.
- "4th, comfort for passengers.
- "5th, sash windows of metal.
- "6th, telephone for passengers.

- "7th, ventilation at ceiling.
- "8th, case for horses.
- "9th, car axle box with oiling pad.

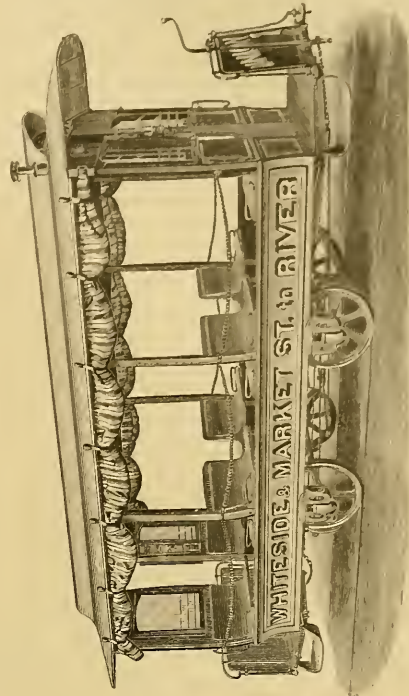

FIG. 49.

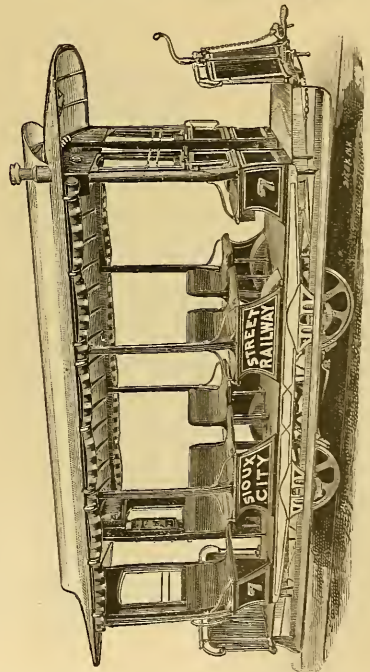

FIG. 50.

- "10th, drawhead with spring and safe hook.
- "11th, brake, central lever.
- "12th, safety, life guards and horse guards.

"13th, car running gear, super spring system."

The foregoing claims were made for the car exhibited at the World's Industrial and Cotton Centennial Exposition at New Orleans. Mr. Stephenson received his first order from the North Chicago City Ry. in June, 1859, for four (4) one-horse cars. He has made for that company 245 cars, of which number eighty (80) were open cars.

The life guard shown in Fig. 47 is in use upon more than 600 cars, and is a valuable idea.

The horse guard has saved the life of many a horse. Without it, when one horse fell, the car ran up onto his rump. The projecting end of the brake rod, frequently tore an ugly hole as he struggled and tried to get up. From this injury I never knew a horse recover, for mortification ensued, and death came to end his sufferings. The horse guard also affords a hold to a human being who might have fallen in front of the moving car.

From the experience gained during my street railway service, I have no hesitation in affirming that the Stephenson cars are thoroughly and honestly constructed in every detail, and very durable.

Messrs. J. G. Brill & Co., of Philadelphia, favor me with the following figures of open cars. They are extensive manufacturers of steam and tramway cars of every description.

Figure 51 shows an open car, seating fifty persons. The seats are arranged *vis-a-vis*, with sash, and at each end there are curtains for the sides arranged in sections and reaching to the sills. The roof is of the class known as "monitor," with movable ventilators. The route is lettered upon the sides and ends. Ceilings are of veneer, decorated. The car is finished throughout with bronze trimmings, and has all of the maker's latest improvements.

The length of car, in all, is 25 ft. 4 inches; width over seats 7 ft. 6 inches; weight, 4,700 lbs.

Fig. 52 shows a one-horse open car, having a length of body of 13 feet 6 inches, width 7 feet 6 inches. Seats are arranged *vis-a-vis*, and accommodate twenty-four persons. An aisle runs through the center, from platform to platform, with enclosed ends, sash and doors as in an ordinary close

horse guards. Trimmings are of bronze. Bell pulls, within easy reach of the passengers, are upon the sides. This car can be operated with two fare boxes, or one movable fare box.

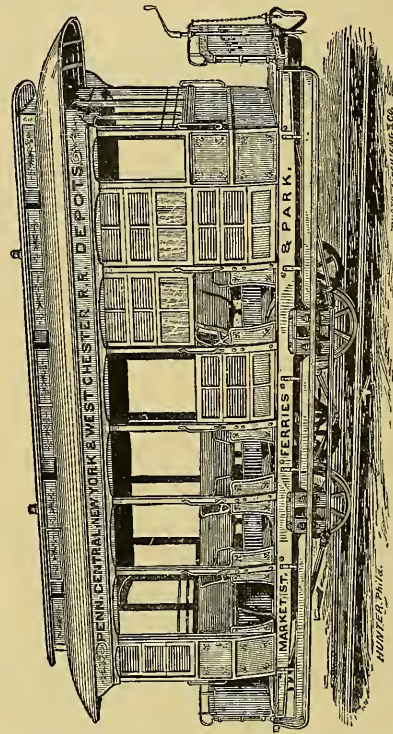

FIG. 55.

The same pattern of car is furnished with enclosed front platform and step, or open platform in the rear, with stationary seats facing to the front. Cars of the same pattern are built for operation with two horses, seating thirty-two persons. In this event the length of car body is 18 feet.

Fig. 53 is a one-horse open car with a seating capacity for twenty persons. It is arranged with patent panels, foot rests, rounded levers for the backs of the seats, which are reversible, and driver boxes. It has curtains, sides and ends, and headlights on the roof. Weight 2750 pounds.

Fig. 54 is an open car, with open ends, having a total length over platforms of 24 feet, and a width across seats of 7 feet 3 inches. The backs are high and reversible and the seats wide, with rounded seat back levers, arranged so as to prevent accidents in turning them over. Gum cushions are provided on the edge of the backs to prevent their being bruised or broken. There are grab-handles on the seat ends. They are fitted with a newly patented metal panel. In the ordinary cars these panels are made of  $\frac{3}{8}$  inch poplar, bent to shape, concave and convex, and fastened to a frame work, which is boxed into the post by gaining out from  $\frac{7}{8}$  to  $\frac{3}{4}$  of an inch, and fastened also to the sills. This gaining of the post necessarily weakens it, to overcome which the posts are made larger, thereby increasing the width of the car, and providing a place for the collection of water, which rots the wood. They are the most vulnerable part of the car, being easily broken, and checking. They are hard to repair without good shop facilities and are expensive. The metal panel overcomes these objections, never wearing out. It also lightens the car. Foot rests are provided on either side of the seat, and driver boxes under the front end of rear seats.

The signs are patented, and are made so that when they are pushed up they will reverse, and can be made to show two, three, or four sides.

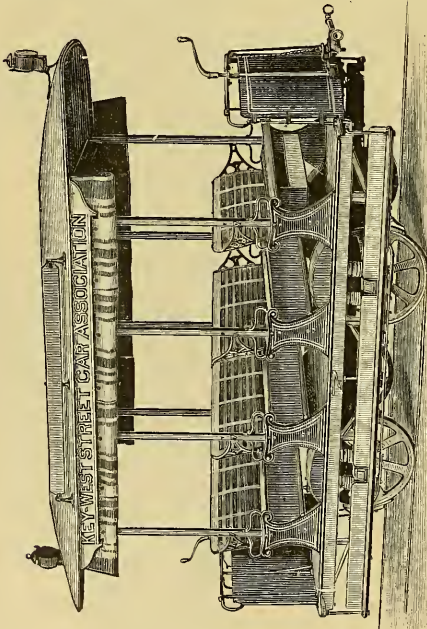

FIG. 53.

car. Sides are paneled to the waist-rail. The side curtains draw up on rollers.

The car has patent "equalizing gear," patented brake-shoes, patent brake, corner irons, braces, and stays, and



The curtains on the sides and ends reach to the sills, and there are lambrequins on the insides. Two end lamps and one center lamp are provided. Rubber balls are fitted to the lower end of brake shaft to prevent injury to horses. They have a seating capacity for forty persons, weight 4400 lbs. These cars are also made to seat 35, 30, 25, 20, and 15 persons each.

Fig. 55 is designed for use in tropical countries, and is intended for operation during the whole year. It has the "monitor roof," with ventilators in sides and ends, extending the entire length of the car body. It has enclosed ends with blinds, and blinds also on sides arranged so that when not in use they can be slid up into the roof. The seats are reversible, and the car has a seating capacity for 35 persons. Extreme length 24 feet; width at seat 7 feet 6 inches; weight 4500 lbs.

Other well-known manufacturers of cars are the Pullman Co., of Chicago, Brownell & Wight Co., of St. Louis, and the Laclade Car Co., of St. Louis.

**The Cregier Rail for Street Tramways.**

Practical street railroad people recognize the following important defects in rails now used:—

The strap rail, which from its low cost is most generally used, is fastened to the stringer on which it rests by spikes

tively, and to repair or take up a girder rail means to take up the pavements, and the chairs that support the rails as well.

The strap rail, designed by Mr. Dewitt C. Cregier, Superintendent of the Chicago West Division Railway Co., Chicago, (see figs. 1 and 2,) shows a longitudinal slot rolled in the rail, between the trams, not wide enough to admit the smallest wagon or buggy tire, but large enough to receive

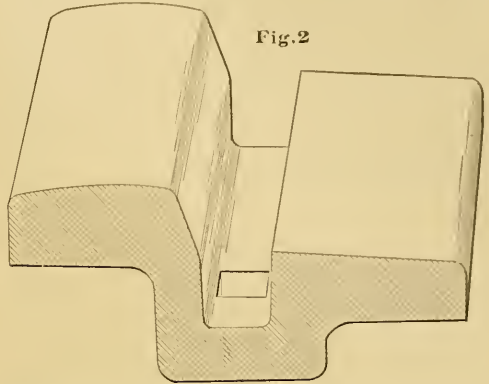

Fig. 2

the head of the spike which is driven through holes in this slotted part of the rail into stringers beneath. It is apparent, from this construction, that the wagon tram can be worn through without effecting the fastening, while the design does not materially add to the expense.

Mr. Cregier's girder rail construction (see figs. 3, 4 and 5) shows a web running down from each tram, so making a *double girder*, the cross section is designed to resist as heavy

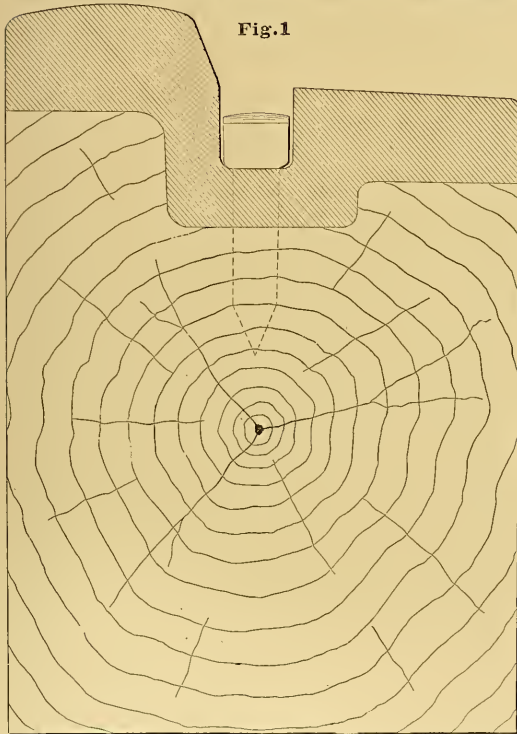

Fig. 1

driven down through the wagon tram, the heads of the spikes fitting into the countersunk prepared for this purpose. As this part of the rail is worn down by travel, the head of the bolt is worn off until, long before the life of the rail is exhausted, it becomes impossible to hold it in place on the stringer it rests upon.

The girder rail in use, is open to the objection that the web can not be placed so as to make both the car and wagon tram center bearing; and as in placing this web on a line between the two, is to throw a transverse strain upon this web, there is a constant tendency to move in or out from its alignment, a fault always present and aggravated by use; while the form of the chair offered, holds the rail posi-

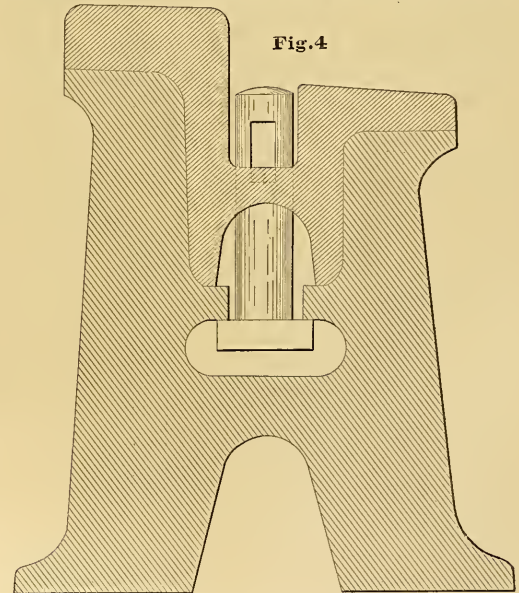

Fig. 4

strains as the single web in other rails, and yet, while forming a true center-bearing rail in every sense of the word, does not call for more weight per foot than accepted standards.

The chair proposed, is of cast iron, spiked fast to the tie, and receiving the rail on two supporting flanges which run up to, and carry the rail through its entire cross section. The fastening is a bolt run up from below through a hole in

the slotted portion of the rail, when a key is driven through an eye in the end of it.

The result is a rail which will keep its alignment, has no tendency to spread since it is not subject to any transverse or tilting strain by either cars or wagons, and which is so fastened to its supports that it may be removed, or the fastenings may be attended to without in any way interfering with the pavements or supports.

The narrow slot in these rails will be filled up at once with dirt, etc., from the street, and present, in use, the appearance of a solid tram.

The Rasmussen Cable Co., at 59 State Street, Chicago, controls the above described form of rail.

Fig.5



### What Is The Coming Power To Move Street Cars?

That this is a subject of intense interest to owners of street railway property no one can doubt who looks over the pages of the magazines devoted to these interests. In treating upon this subject I shall avoid all technicalities, as far as at all practicable, addressing myself rather to the owners of street railroads, the men who have the money invested, than to the engineers.

In the first place, let it be remembered that street railroad tracks in large cities, of a necessity, are built so that the rails are about on a level with the paving blocks, and the inside part of the rail for vehicles a little lower so as to form two gutters into which the dirt of the streets is always washed by rains, and that the ordinary condition of these rails is, that they are dirty.

Again, the rule is at least, that these tracks have been built with reference only to the weight of the cars, and the loads now in use. In the winter time in northern climates, for weeks at a time, these rails are overlaid with snow, or slush, or ice, in fact they are anything but clean.

Again, it is the exception if somewhere in the system a

Fig.3

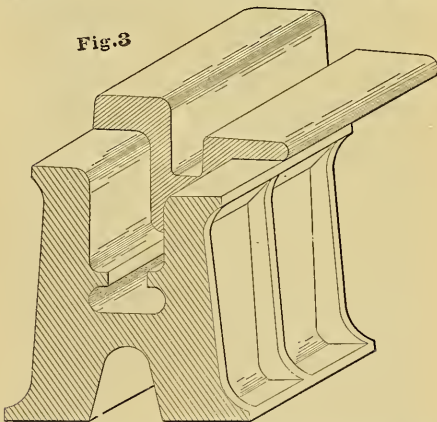

heavy grade is not to be met with; even in Chicago these are present at the approaches to all the bridges. Having regard to these conditions, it is plain why horse power answers the purpose so well. The horse can pull the car at some rate of speed, and at some cost, to a certainty, over any kind of track, and so maintain a uniform and reliable travel of the cars, without which, street railway property is valueless; but as cities grow, the distance between business centers and residence parts becomes greater, passenger travel becomes heavier, and the expense of moving the people increases, to say nothing of the increasing importance

of the time lost in getting from the one place to the other.

Rapid transit is the outgrowth of this condition of things; and while the horse can move a load slowly to advantage, the cost of operation increases so fast with increased speed, that very soon a point is reached where it becomes economical to substitute other power.

Successful ventures in one city in the line of rapid transit leads to their being duplicated in other cities, and these new lines with their superior facilities effect the revenue of the older roads, and in turn these are being forced to change their power. This movement is now full of life everywhere and is irresistible, hence it may be fairly stated as a business proposition that horse power "must go" from all important metropolitan lines.

Assuming a disposition to change the power, it must be said that it is no easy matter, by the closest consideration of the subject, to determine what is best to do. Not only cable lines, electrical, steam, air, and gas apparatus are urged with great fervor, by their respective friends, but a multiplicity of each form of power is offered. I think it will rob the subject of many of its complications by dividing these different forms of new power into two classes. The cable, or positive pull, is the first, and all forms of traction motors, the second. By traction motor I mean any proposed machine or device which depends for its propulsion purely upon the principles used in locomotive engines—the traction or friction of the car wheel on the rail. Without prejudice for or against any of these devices, I submit the following points as they occur to me, which have not been met:

1st. The locomotive engine, we will say of ordinary type, weighs 40 tons; its weight being almost entirely on the drive wheels. It pulls its train on a clean rail standing up three and one half inches above any obstruction liable to make the wheels slip; when the rail is clean, I need not say that this is a perfectly successful machine; the load it will pull, or the grade it will mount, depends only upon the size of its cylinders and the weight on its drivers. But mark, as the power of the engine is increased in the size of its cylinders, a corresponding weight must be added upon its drive wheels; and still the power of the machine depends upon the rail it runs on being clean. The engine that pulls 30 loaded cars 30 miles an hour, on a clean rail, will stand still in a snowdrift and be powerless to move itself alone, the wheels revolving and the engine standing still. The story of the Irish woman who, dissatisfied with the price paid for a pig killed by the company, suspended traffic on the railroad by soaping the rails, is an old one.

Mr. Augustine W. Wright, a leading authority on street railway matters, and President of the Society of Western Engineers, working down this problem reached the conclusion that a traction motor on a street railroad in Chicago, to meet the worse conditions successfully, would require ten times the weight necessary to perform the same service on a well built steam railroad track. It then follows that the motor must be so heavy that the entire track construction must be overhauled and put in shape to carry this heavy load, and the expense of construction and necessary cost of maintenance, in his judgment, over-balanced the economical value of this form of power. It will require a long and successful operation of any motor of this form to demonstrate the incorrectness of this position if it is possible to do so all, which I doubt.

2nd. Assuming the first objection to have been met successfully, and taking it for granted that a steam engine on each car, or a steam engine to pull a train of street cars can not be permitted, then it remains only to look at the matter of first cost, and cost of operation, and the question of the character, simple or otherwise, of the device offered. Passing the gas and air engines, as not yet sufficiently developed to be criticised, it can be assumed that some form of electrical motor is the most prominent traction device. There is but little use in discussing the claims made by the various inventors of the different forms of electrical railways; it will be enough to glance at the actual performance of such as have actually made at least an experimental test.

The Bentley-Knight system has many strong points, and



for street work in large cities seems to have been worked down into detail closer than any other one which proposes to use a conductor located in the street. Its claims are fully set out in THE STREET RAILWAY GAZETTE for February, and the cost of construction given, without including tracks, cars, etc., at \$214,000 for 35,000 feet (contracted for in the city of New York) or about \$30,000 per single track mile. The report made thereon to President Lyon of the Third Avenue Surface Road of New York, by a committee of experts detailed by his company, states:

"The committee found that the motor's work was perfect. \* \* \* More power will be required to operate cars with electric motors than where the power is applied directly, as by cable or horses; furthermore, the electrical system lacks the advantage of counterbalancing cars on grades of cable roads; consequently a third more power will be required for reserve force, whether it is in constant use or not. The expense of electricity would be at least 25 per cent. greater than that of the cable. At least 25 H.P. would be required for each car for the electric motor on Third avenue. It would require at least 3,000 H.P. to work the electrical apparatus on the Third avenue line, while not over 1,000 H.P. would be necessary to operate the cable system."

This result was obtained from an examination of a road at Providence, built with the view to exhibit its workings under all difficulties. It had one sharp grade of five feet in the hundred, with an abrupt curve of 45 feet radius near one end of the line, the road being 800 feet long in all. On this road is one car carrying a 25 H.P. motor weighing 1,500 pounds.

It suggests itself to my mind, that if this loss of power is found in this trial line, there would be still a greater loss when the conductor was lengthened to, say, 2 or 3 miles.

Another system of electrical railway is known as the storage battery class where accumulators, as they are called, are placed in the car and charged with electricity at some central station. This plan just now is attracting a great deal of attention, having the hopeful endorsement of quite a number of people prominent in street railway matters. It is only fair to say, however, that no performance of any motor of this class, in this country, in actual service, can be cited as making a practical success; though this is promised quite freely.

It is difficult to see just how a storage battery traction engine is going to get over the first objection named in this article, simply by virtue of applying its power indirectly through a battery, instead of directly through a motor; if it does all this, it is still more difficult to understand why generating the power in an engine house, transferring it to a storage battery, and from thence into a dynamo on the car, will be accomplished with less loss of power than in the case of the conduit, or conductor system, where the storage battery is not used at all.

In a recent paper on "Electrical Railroads," read before the Electrical Department of the American Institute, Mr. George W. Mansfield gives in great detail the relative loss of power. He says that directly applied by a conductor, 64 per cent. on the engine power can be obtained to drive the car with, while with the accumulator, or storage battery, only 50 per cent. can be obtained.

Assuming his deductions to be correct, it will cost more to run a storage battery motor than the direct electric motor.

3rd. It is not possible, in the present early stage of electrical street railway powers, to get any data upon which to base an intelligent opinion of how long the apparatus will last, and consequently, what would be a fair statement of the cost of repairs. But among practical people it is conceded that it requires special expert work to maintain a dynamo at a high rate of efficiency, and very much more care and attention than any form of steam power; while storage batteries are classed as the most abstruse of electrical appliances, so far, and the least understood by any very large number of men.

If it is true, however, as claimed for the Julien accumulator, that a perfectly indestructible storage battery has been discovered, this element disappears so far as the battery is concerned, and we have reached a point where it is at last

practicable to have a battery located in every house to be charged with a circuit wire from which to draw the current necessary to maintain incandescent lights, and give off the force necessary to drive the small powers in general use; and, of course, it will be adopted for this purpose at once.

For street car use it has the advantage, in one direction, of adding one and one half tons weight to each car fitted, since, to this extent, the necessary traction is provided for; but, as has been stated, as the weight increases so does the necessity for first-class track construction, wear and tear, cost of maintenance, etc., etc. For instance, if on the 500 cars in daily operation on the lines of the C. W. D. Ry. Co. in Chicago, this storage battery system was in use, there would be in excess of the present wear on the tracks, that wear due to moving over the lines 750 tons of nonpaying load, or what would amount to pretty nearly double the present tonnage represented by the passengers carried in one day. It can not be true, from this fact, that no change or alteration of track is necessary in the introduction of this system.

These are a few facts from a practical standpoint that induce me to believe that the coming power for moving street cars will not be traction machines of any character, and more certainly that they will not be driven by electricity. I think, as the change is made, it will be to some form of power that will positively take hold of and operate a street car independent of any power on the car itself; and that the device must be of so simple a character, and constructed upon such well-known principles, as will place its operation and maintenance within the range of ordinary intelligence.

It is a long step ahead for people who have been in the habit for years of moving their cars with horses, to substitute steam power, even when it meets the requirements I have named. A complete reorganization of the managing staff is a first necessity. To get out beyond this, at one jump, into a class of machinery complex and delicate in its character, but little understood at best, and then only by a few experts, is too much to expect of the average street railroad owner. To all this, of course, the answer is, the world moves; we have not reached the limit by a great deal, and out of the difficulties and objections now surrounding the problem it is not at all certain, but someone will work successfully and offer a better, and plainer and cheaper motive power than the cable has proven to be.

But this result when reached, so as to commend itself to conservative people, will have to pass through the common ordeal of well-sustained operation. Nothing is yet offered that does this even theoretically. If the first cost of a cable system actually demonstrated to be reliable, could be brought down to, say, \$25,000 per mile, then the cost of installing it would be but little, if any, more than the cost of equipping a street railroad with horse power and the necessary buildings, etc., etc. Then, if the cost of maintenance could be reduced to the ordinary and usual depreciation in machinery due to wear and tear without special destruction to any one of its parts more than to another, it is doubtful whether there would be anything left to be desired.

Mechanically the power of a steam engine, when delivered in the line of a direct pull on the body to be moved, is the most economical force now known anything about for practical use; and every time the application of this power is removed one degree by indirection, it is manifestly done subject to a direct loss of energy to that extent that will show itself in the coal bill. At the risk of being thought old-fashioned, I state it as my conclusion that for traffic on streets in a city with or without heavy gradients, the cable in some form is destined to do the work; for suburban places where clean rails above the level of the road are tolerated, some one of the many forms of steam motors will go in.

The Baldwin Locomotive Works, for instance, can build a street motor that is noiseless, and recognizing the common laws of gravity and traction, they know just what weight must be put on the car to make its wheels hold the rail; and I think they will agree with me, as the result of their construction of thousands of first-class locomotives, that driving an engine by steam, or gas, or electricity, or wind even, will not make its drivers stick to the rail *per se*.

## The Meigs Elevated Railway.

During a recent visit to Cambridge, Mass., we took the opportunity of examining the temporary plant and equipment of the Meigs Elevated Railway, which has been receiving of late so much attention from the Boston city government, and eminent railway engineers. From Mr. Joe V. Meigs we received every possible attention. Steam was ordered to be "got up" immediately, for an exhibition, and, in the meantime, we ascertained the following facts and information:

At 225 Bridge street, East Cambridge, are the offices, machine shop, and temporary tracks of the Meigs Elevated Railway Construction Company, which was formed and organized under the general corporation laws of Massachusetts, for the purpose of building and constructing elevated railways and equipments, according to the plans, specifications and patents of Joe V. Meigs, of Lowell, Mass.

The present exhibit has required an outlay of \$75,000. A magnificently equipped passenger car was recently destroyed by fire (supposed to be the work of an incendiary). This was a loss of \$10,000, as the car, about 51 feet long, had been built and equipped and upholstered in an elegant manner, to show, of course, the capabilities, capacity and

The following condensed description will show that the Meigs car is of an ingenious and novel construction:—The cars have rounded ends, because that form will push a fallen person back upon, not from, the platforms; their frames are of iron, because stronger, and won't burn; the platform is a continuation of the floor, because that is the strongest form; the gates slide up and down out of the way, and ladies' dresses are not caught; the floors are double, and iron lined, because they don't burn; the walls are upholstered, because if one is thrown against them, they do not cut or bruise; the separate seats are fastened down, are of malleable iron, are capable of being turned up out of the way, have no legs occupying the space for foot or bundle, and are upholstered upon all salient points, so that in case of accident passengers can not be cut by them; the doors are double, permitting easy ingress and egress; the roofs of platforms will interlock and cover space between cars, keeping out weather and dust; the windows open in the opposite direction to movement of train, and permit plenty of fresh air, without draft, in all weather, letting in no dust. Ventilation is secured by outsock, from top and floor of car, occasioned by movement of train. The couplings permit of operation from engine so that train can be broken up and brakes put on from that point. When cars are uncoupled

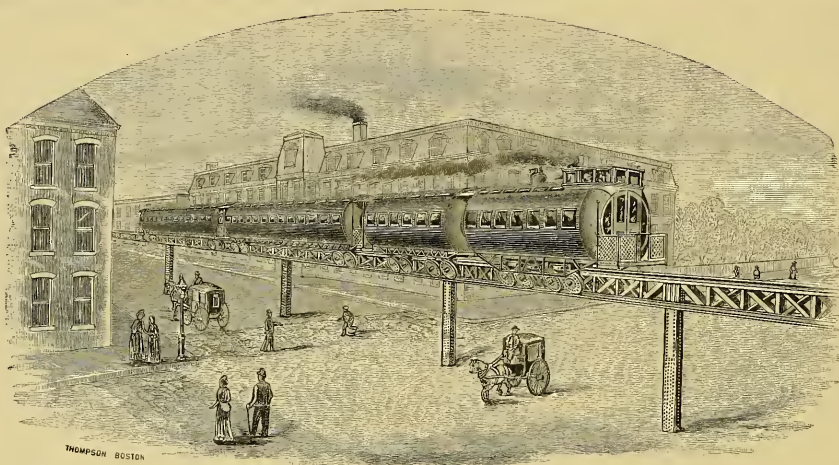

comfort that were possible in the form and style of a Meigs passenger car. The car that was destroyed weighed 34,000 pounds with its trucks complete. It was from 8000 to 14,000 pounds lighter than ordinary cars of its length, while its strength was much increased. It could seat 33 per cent. more passengers; 84 passengers could be seated.

The body and frame of the car now in course of reconstruction, with plainer fittings, allows of experimental or exhibition trips; the general contour and arrangement are seen and easily understood. The departure from the usual forms and combinations of railway cars is very marked, and the inventor can certainly be credited with originality of ideas. The housings of the engine, tender and car are all of them cylindrical, because it is claimed, as a scientific and well-known fact, that this form gives the least wind strain; it also requires the least covering material, and affords a greater seating space. The annexed table gives a comparison between the Meigs passenger and other standard cars.

Kind of Car.	Seatings.		Weight of Empty Train.	Wt. of Train per Passenger.
	Each Car.	In Train.		
Pennsylvania Standard Cars.	52	156 (3 cars)	126,000 lbs.	807 lbs.
Metropolitan N. Y. Elevated Standard Cars.	48	192 (4 cars)	95,400 lbs.	497 lbs.
Meigs' Elevated Standard Cars.	72	216 (3 cars)	102,000 lbs.	472 lbs.
Meigs' Elevated Standard Cars.	84	252 (3 cars)	102,000 lbs.	404 lbs.

their brakes go on. The cabs all ride on Vose springs, unexcelled for strength and easy riding. The wheels are of large size, because they roll fewer times in traveling a given distance. The wheels roll over continuous stringers, resulting in easy riding and little repair. The wheels are turned to size, because such wheels roll smoothly, producing the least strain upon track or car, and eliminate the evils caused by wheels out of round. The wheels have increased treads, because surface adds to durability of wheel and rail. Each wheel runs in its own time, its cap cavity containing a bath of oil in which the wheel runs, thus reducing friction, and removing all cause for hot boxes.

The trucks are astride of the tracks for 3 ft. 6½ in., and do not depend upon their wheels for security against derailment—nor yet upon the integrity of the rail—but upon that of the whole track. Derailment could only occur when the whole way is destroyed or the trucks of the whole train are swept from under it. Impossible.

A new feature in trucks has been introduced, by which all centrifugal strains are absorbed by side springs.

The engine is an anthracite burner; is slotted yoke connected; has fire box, 54½ x 54 x 55 in., 5 ft. shell, having 208 2-inch tubes, 84 inches long. Made by Russell & Sons, of the best Benzol steel, to stand a working pressure of 150 lbs. per square inch. It has two cylinders 16" x 32", coupled to two 45 in. drivers, 6½ in. face, applied by controllable squeeze, to 5 in. faced rails. This squeeze can be used for brake power, and thus the engineman has complete control



over his train. The exhaust is without contraction and is quite noiseless. The ordinary link valve motion is used. It is covered with a cylindrical cab, which serves to keep heat in and bad weather out. It looks like the tender and car. The engineman commands the train—its motive power, couplings and brakes, from a pilot house high up at the front of engine, simply, and without complication, governing every part of the engine by hydraulic power, through the instrumentality of valve levers arranged upon a table in front of him. He is in easy communication with the fireman at the rear end of the engine. The tender of the engine carries two cylindrical water tanks, capable of holding 1800 gallons of water, and has ample coal bins; a boiler to make steam for heating the train (unless it be drawn from the engine), and coils of pipe to heat air brought from the front of the train, and led into the cars through self-coupling pipes. Electric communication from engine to cars, and vice versa, is provided for through the draw bars; the integrity of the train will thus be indicated to the engineer. If a car should by accident be detached, its brakes go on automatically, and the engineer will be notified of his loss. They can also be put on and off by hand from the car.

When the engine, tender and passenger car were brought out for exhibition of running, we took our stand on the platform, and found the motion easy and without jerks or oscillations. Sharp curves and steep grades were of no account whatever, and derailment seemed impossible. The train was started and stopped with ease. After running some distance, on a level, it was stopped at the bottom of a steep curved ascent, and then started again, the cars going up and round the curve without any difficulty. The ease of transfer about the short curves, and up the great grades, and the holding of the engine at will upon those grades, is a wonderful feat in engineering.

The Meigs patents cover very fully all post supported railways and railway tracks, having the combination of lower rails which carry the load, bearing wheels which roll upon said lower rail, upper vertical rails for the application of draft power and braking power and to receive side thrusts, horizontal wheels to bear against said upper rails, and a truck which straddles the frame girder and carries such wheels, and also supports the body of the carriage upon its upper platform.

The Massachusetts Legislature, by Chapter 87, Acts of 1884, provided that "No location [of the Meigs Elevated Railway] for tracks shall be petitioned for in the city of Boston until at least one mile of the road has been built and operated, nor until the safety and strength of the structure and the rolling stock and motive power shall have been examined and approved by the Board of Railroad Commissioners or by a competent engineer to be appointed by them, and to be paid by said corporation a price fixed by said Board."

After examining the structure, rolling stock and motive power of the Meigs Elevated Railway as they existed Oct.

27, 1886, the Board appointed General George Stark of New Hampshire, a competent and independent civil engineer, to act upon the approval of the structure, rolling stock and motive power. And his report thereon, dated Dec. 23, 1886, has been approved by the Commissioners, who "will in due time take formal action upon the points submitted to the Board." In summing up his investigations the examining engineer says:

"The experimental section of the Meigs Elevated Railway now in use at East Cambridge is, in my opinion, abundantly strong for its intended use as an elevated railway track, and is safe for the passage of its equipment. The rolling stock and motive power used thereon is also strong and safe for its intended use, no breakage having occurred, or being likely to occur, that could imperil personal safety either in or out of the cars. A line of railway properly constructed on this principle for passenger or freight traffic, and equipped with such rolling stock and motive power, on this principle, as the Meigs Company is now prepared to perfect and build, would, in my opinion, be at least as strong and safe for any kind of traffic as the ordinary surface or elevated steam railways now in common use. In view, however, of the imperative necessity for the best class of design and construction in everything appertaining to an elevated railway, I think it would be wise for the State of Massachusetts, through its Board of Railroad Commissioners, or otherwise, to regulate the strength and design of all materials used in construction, and the weight and design of equipment to be run, etc., as is done by New York through its 'Rapid Transit Commission' for elevated railroads in that State."

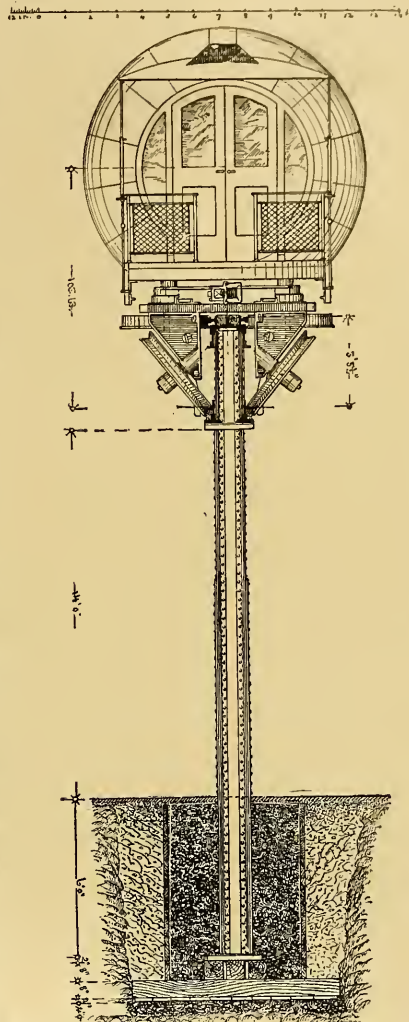

The above cut is an end representation of the car upon the track—its trucks, the post, and its setting; showing the trucks astride of the track 48 inches.

### Strikers Defeated.

The street railway strike, in San Francisco, which had lasted about four months, practically ended March 5, in the defeat of the men. The dynamite explosions, which occurred along the line of the cable roads, and which were attributed to the strikers, lost them public sympathy, and they have been obliged to abandon their line of opposition stages.

The little band of street railway strikers at Lexington, Kentucky, have also incurred public displeasure by their violence. About seven o'clock on the night of March 4th, three street cars were attacked, "it is supposed," by strikers. Rocks were thrown into a car on East Main Street, and on North Broadway and North Limestone. Each car was similarly attacked. Glass was broken out and other considerable damage done. The driver of one of the cars fired four shots at the attacking party, with what effect is not known. The strikers became exasperated when they saw their places occupied by fresh men.

The "progress" of the Boston street railway strike is tersely described in another column. But it is interesting to observe, further, how public sympathy with the men subsided as violence was resorted to.

# The Street Railway Gazette.

PUBLISHERS:

THE WRIGHT-MONROE COMPANY.

Augustine W. Wright,	President.
E. V. Cavell,	Secretary.
S. L. K. Monroe,	Treasurer.

### GENERAL OFFICES:

CHICAGO, NEW YORK, BOSTON.

CHICAGO:

9 LAKESIDE BUILDING.

P. G. Monroe,	} General Manager.
G. C. Minor,	
William Hughes,	

NEW YORK:

181 BROADWAY.

Henry C. Lockwood, Resident Editor and Manager.

BOSTON:

198 WASHINGTON STREET.

T. P. Pemberton, Resident Editor and Manager.

### BRANCH OFFICES.

ATLANTA, Ga.: Chamber of Commerce Bldg., Wm. Minnigerode, Mgr.  
SAN FRANCISCO, Cal; 1222 Bush St., G. W. Fairchild, Manager.

"So far as New York city is concerned," says Mr. George Bliss, in an article on "Constitutional Reform in New York," "I think it would be a good thing to make it possible to place in the Commissioners of the Sinking Fund the powers now possessed by the Aldermen with reference to grants for street railways." \* \* \* \* "I predicted to Governor Cleveland that the result of the bill as it stood would be to make an auction room of the Aldermanic Chamber." \* \* \* \* "The consent of the Commissioners of the Sinking Fund is now required to the leasing of any land to or by the city, and there would be consistency in letting them fix the term of any grant to occupy the streets with railroad tracks. If the subject of street railroads is touched in the convention, I think provision should be made by which only a single track can be placed in our ordinary cross-streets, so that cars may run on one street going one way, and on a parallel one going the other. This would go far to minimize objections to tracks in streets."

THE House Committee on Railroads, at Springfield, Ill., March 4, discussed McElligott's bill providing that the law requiring elevated railroads to obtain consent of a majority of the property-owners on each mile shall be amended so as to only require the consent of a majority on the entire line. The measure was referred to a sub-committee composed of Messrs. Farrell, Messick, and Hunt.

TRANSFER tickets, as practiced on some of the New York street car lines, are much desired in other cities. President Yerkes was recently asked if the plan could be adopted in Chicago; and he expressed himself willing to make an arrangement with the other companies to that end. Boston and New Orleans cry aloud for the same privilege.

CABLE RAILWAYS, as far as construction is concerned, have made but little progress during the past two or three months; but, as a correspondent at Kansas City observes, large numbers of draughtsmen have been busy completing plans and getting everything in readiness to preclude any delay as soon as the weather opens sufficiently to allow excavating and outside work. "The busiest offices have doubtless been those of the Metropolitan street railway and those of the Grand avenue cable line. These two places have been beehives of industry."

MR. THOS. ALVA EDISON, was one of the first electric roadbuilders. The United States patent office has awarded priority of invention in electric railways in America to Mr. Stephen D. Field, a member of the distinguished Field family, whose papers were filed in Washington, March 10, 1880 (a caveat having been filed May 21, 1879); those of Dr. Werner Siemens—whose electric railway experiments were tried at Berlin, as far back as 1867, and there carried to a successful issue in 1879—were filed (at Washington) on May 12, 1880; while those of Mr. Edison were filed June 5, 1880. The "early" Edison electric locomotive has been abandoned; but an improvement has been followed up. And a telegram from Jacksonville, Florida, March 3rd (inst.) says, "Edison has improved considerably in health since arriving at Fort Myers. He is not spending his time idly, but experiments constantly with various inventions, chiefly in the line of applying electricity as a railroad motor."

"HOWARD'S GOSSIP" emphasizes the fact—repeatedly pointed out in THE STREET RAILWAY GAZETTE—that the Long Island Elevated Railroad Company's franchise, for an elevated railway on Atlantic avenue, has been "under consideration" a long time. Joseph Howard, Jr., says that "the Brooklyn Board of Aldermen acts as though it was looking for 'boodle' in the matter of rapid transit. There are 800,000 people in that city who are interested in rapid transit. One of the propositions is for a road on Atlantic avenue. As the greater part of that avenue is now given over to a steam surface road, an elevated road would be a change for the better. So the people living on the road thought. They favor such a road. A commission reported in favor of it. Not half a dozen persons opposed it; but the consent of the Board of Aldermen is necessary, and there the matter has stuck for months. Mayor Whitney has sent two messages to the board urging action, and 1,000 property owners have sent a petition to the same end. But still the aldermen refuse to act one way or the other. This looks suspicious, to say the least. Lower Atlantic avenue is dying for want of rapid transit. The law is now well defined. Under the decision of the Court of Appeals a property owner has simply to show his measure of damages and he will get them. There is an imperative necessity for the work, and no satisfactory excuse can be given for the refusal of the Brooklyn aldermen to act on the question."

AT Springfield Ill., March 1st, in the Senate Committee on Municipalities, Senator Eckard's bill, which corresponds to Mr. Meyer's bill in the House, forbidding the granting of street-car franchises except by consent of a majority of the property-holders on each mile, was read and ordered back with the recommendation that it pass. The gentlemen who went down from Chicago to address the committee on this bill were tendered a vote of thanks for not doing so. Truly it may yet be said that "silence is golden."

ELECTRIC RAILWAYS naturally attracted special attention at the fifth meeting of the National Electric Light Association, held in Philadelphia, February 15th, and succeeding days. A letter from Mr. Van Depoele was read, wherein it was stated that hardly a year had elapsed since the propulsion of street cars by electricity was but a mere experiment. He maintained that the electric motor was sure to introduce itself even more rapidly than had been the case with electric light, on account of its economical and practical features. Undoubtedly, he said, the heaviest work ever done by electricity anywhere has been in the city of Minneapolis, Minn., where an electric locomotive of 8 tons weight was used for over a period of about ten months, bringing ordinary railroad trains in the city, the steam engine only being allowed to come within a certain distance of the town. The cars used on this road are 11 tons in weight empty, and the train consisted generally of from 2 to 4 of these cars, and in the summer time were always crowded to the utmost capacity. This work of bringing in and out the trains began at 6 o'clock in the morning and stopped at half-past 11 at night.



## Street Railways of Massachusetts.

The eighteenth annual report of the Board of Railroad Commissioners for the Commonwealth of Massachusetts, being that for the year ending Sept. 30, 1886, contains information furnished by 43 street railway companies in the "Old Bay State." During the year nine new companies were incorporated, which are included in the list; whereas, only one new street railway company was formed in 1885, and four in 1884. The Boston Consolidated Street Railway Company was incorporated under a special act, being a consolidation (or amalgamation) of the Highland and Middlesex companies, and should not really be regarded as an additional corporation. The property and franchise of the Salem Street Railway Co. were sold to the Naunkeag Street Railway Co., June 1, 1886; and those companies have been consolidated. The Albany street railway is used for freight only. The Hoosac Valley and the Lowell and Dracut lines are not completed, and are not in operation.

The aggregate capital stock of all the street railways of the State, *i. e.*, the 43 companies (as they stand in the Commissioners' report), is \$9,125,645.00, being an increase of \$1,048,545.00; their gross debt has also increased \$519,341.60, and now amounts to \$5,464,729.61. The aggregate of stock and gross debt is now \$14,590,374.61.

One corporation made a dividend of 22 per cent., one of 12, one of 10, five of 8, one of 7.03, one of 6½, seven of 6, two of 5, one of 4, one of 2, one a regular dividend of 8 and also an extra dividend of 30 per cent. from the surplus of previous years; while twenty-one (including the nine new corporations) declared no dividends. And the Albany street freight line made a deficit of \$338.34; while the Charles River company made a deficit of \$3,876.32.

The average rate of dividend on the total amount of capital stock was 5.41 per cent.; and the net earnings (interest deducted) amount to 5.42 per cent. on the aggregate of capital stock and gross debt.

The whole length of track, including branches, sidings, and double track, amounts to 440.135 miles, being an increase of 64.227 miles. The average cost was \$17,272.11 per mile for permanent way, \$8,663.31 for equipment, and \$9,169.82 for land and buildings; making a total cost of \$35,110.24 for each mile of road owned. The number of round trips was 2,878,005, an increase of 179,667 over the previous year; with a mileage of 19,661,675, an increase of 1,494,056. Passengers were carried to the number of 112,087,384, being an increase of 11,340,598 over the number carried during the preceding year. The number of passengers carried on street railways exceeded the number on steam roads by 36,244,803.

The gross income was \$5,878,583.05, an increase of \$684,145.05. There was an increase of net income of \$149,987.08; with a decrease of dividends paid amounting to \$12,973.75.

The average amount received for the conveyance of each passenger was 5.25 cents (nearly 2½ English pennies), and the average cost of carrying each person amounted to 4.33; the net profits to the companies being 0.92 cent, against 0.87 cent as compared with last year. The average cost of a round trip was \$1.69, with a profit of 35 cents, being an increase of 2 cents from last year.

The whole number of horses was 10,789, being an increase of 1,004; the number of cars was 2,289, showing an increase of 175, and the number of other vehicles was 150. The number of persons employed on street railways was 4,615, being an increase of 512 over last year. The number of accidents reported was 86, of which nine were fatal. The number injured the previous year was 96; fifteen of whom were killed.

By recent legislation (Chapter 140 of the Acts of 1886), street railways are made subject to actions of tort in cases of loss of life by negligence. This was intended to cure a defect in former legislation relating to fatal cases of accident on railroads. Street railways are also authorized to use the cable system as a motive power (Chap. 337). By Chapter 229 each of the street railways authorized to run cars in or into Boston may consolidate with any other such

railway, and may, with the consent of the Railroad Commissioners and of the aldermen of the city, maintain the cable system of motive power. Two consolidations have taken place under this Act, but there has been no change of motive power.

Boston, the capital and metropolis, now with a population of about 400,000, has about 136 miles of street railways within the city limits; and these continue, beyond the municipal boundaries, in various directions, to the extent of about 112 miles.

With regard to "other motive power" than horses, Mr. Calvin A. Richards, president of the Metropolitan Railroad Co., gave an explanation thereof, which goes far to explain why there has been no change of motive power in "cultured Boston." President Richards, in his annual report, said:

"The subject of other power for propelling our cars has received much attention, and been the cause for discussion at most all of our meetings during the year. The two methods claiming most attention being the cable and the electric power. In case of cable power, it has seemed to be a subject requiring the most careful investigation. The one obstacle presenting itself is the peculiar topography of our city, and the extreme narrowness and crowded condition of our streets. Engineers and experts with cable experience have pronounced the use of cable power in Boston of very doubtful expediency, and, at the most favorable view, an experiment of great cost, with the majority of chances against its success. It would cost hundreds of thousands of dollars to prepare our road-bed and to put in the conduits for cable purposes, which would all be lost if the experiment failed. Power houses, with costly engines and machinery, would have to be acquired; and your directors, while fully alive to the importance of a change in our motive power, have hesitated before embarking upon this kind of enterprise. The President has visited the most of the cities of this country, where cable power is used, and carefully examined into the cost and practical working of the whole system, and he has reported that he can not recommend his company to make such an enormous expenditure upon such an uncertain basis.

"The other and most important subject is electricity as a motive power. Attractive at once, as it demands in one way but a small outlay upon our road-bed, and in another none whatever. There are now a number of electric roads in operation in this country, and they are working with a very fair degree of success. The one obstacle towards their adoption in our streets being the source from which the electric motors take their supply. This is done on these roads in different ways, either from a wire stretched by the roadside overhead on poles, or by the substitution of a third rail laid between the others, and the electric current passed over the overhead wire, or through the rail. Both systems being entirely impracticable for us. The third and coming method needs no alteration or expenditure upon our tracks or road-bed whatever, it being the accumulator or storage battery system. This a plan by which the force or power is placed in boxes or accumulators, and then placed in our cars, or in a separate motor. But one power house with large engines and dynamos would be required. Positive success has been proven in Europe and in this country with this plan, and experiments are now being made as to the best kind of motors, by parties who will soon be able to equip ours or an other road, with separate motors, or fit our cars with motors. The whole plan certainly looks very well, and if successful, of which there seems to be scarcely a doubt, a new and very promising career of prosperity for our road will open at once."

President Charles E. Powers (Boston Consolidated) expressed himself as hopeful with regard to the cable system as concerning electricity, saying: "The time has nearly arrived when 'the cable' or 'electricity' will be substituted to a considerable extent for the horses as a motive power. Should either or both be adopted, our road is peculiarly well adapted for it. Our real estate and buildings could be utilized for cable or electric purposes without any great expense."

New England Office, THE STREET RAILWAY GAZETTE.  
198 Washington, Boston, Mass., March 1, 1887.

The street railway strikes, which have agitated public sentiment in Boston, and adjacent towns, the past month—which have been dilated upon under displayed captions in the local press, until the subject has been written up *ad nauseum*—would occupy a whole number of THE STREET RAILWAY GAZETTE; and then the half would not be told.

The outcome and side issues are what claim special attention. And a synopsis of "the trouble" may be given in a few words.

The employees struck for ten hours work within twelve hours, and because certain changes, and alterations and modifications, dictated by them, were not granted. The presidents and road officials have exhibited their firmness and determination in two things; first, in withstanding all overtures for a relaxation of the present system, as presented by the malcontents; secondly, in securing every available opportunity and chance to accommodate the public, by employing and training new hands, and calling for protection from the mayor and police authorities. There has been great financial loss on both sides; the citizens have been put to inconvenience, and subjected to extortion and extra expense; the loss of time to the road employees has been something enormous; the moral tone gradually sunk into impudent defiance, and respect for public and individual rights has been almost ignored. Public sentiment has of course been divided, as to the cause of complaint—one party siding with the road officials, and another with the employees, whilst all parties condemn acts of violence, and breaches of the peace. Assaults and depredations have been frequent, and when arrests were made, the punishment meted out to the offenders has been severe. The unemployed and discharged men are surprised and disappointed in finding that "there is as good fish in the sea as was ever taken out," and that their former positions are being rapidly filled.

Without any consideration or discussion as to who is in the right or in the wrong, one fact is unmistakably evident: That the city street railway companies are tired of being bored by labor committees every few days, and, desiring to do justice to both stockholders and the public, will conduct their business as they think best. The employees say they are well treated and paid regularly. Their grievance of too many hours, if removed, would be, probably, followed by further demands; and it is about time that railroad companies and the public should be no longer subjected, as they have been so constantly of late, to high-handed action of workmen and employees, to inconvenience and expense, to assault, riot, and the destruction of property.

The first fruits of these miserable strikes are:—That both the South Boston and Cambridge street railways have gradually overcome their difficulties—have employed many new men; that a permanent co-operative coach or omnibus company is talked of, as additional accommodation in South Boston; that a new railway is also contemplated, and that, before the summer arrives, there will be more conveyances and railway cars for the convenience of the public. That there are thousands of men—honest, temperate, industrious, and willing to work—who can be placed in positions of conductors, drivers, and stablemen is evident, if railroad officials will arrange judiciously, and without detriment to public safety, for their proper training, etc. And it is gratifying to know that "every line of the South Boston Railroad Company is now in full operation."

Colonel Bancroft, of the East Cambridge street railroad, acted with much coolness, foresight, and determination in the midst of great disturbance. He said: "The company has its rights, and so have the strikers, and so have the great people who may walk or ride, in whichever manner they please; but the rights of all require that all violence shall be suppressed, and the guilty ones punished."

The strikers, be it observed, disclaim all responsibility for the recent rioting and disturbance; and they have published statements to that effect in the daily press. This is satisfactory, so far as it indicates that the men are ashamed to own (publicly, at least) that the assaults and injuries committed are countenanced by them.

## Patents.

The following list of recent Patents relating to Inter-mural traffic is specially reported for THE STREET RAILWAY GAZETTE by Wm. G. Henderson, Solicitor of American and Foreign Patents, 935 F Street, Washington, D. C. A copy of any of the following will be furnished by him for 25 cents.

- 356,906. Railway car wheel—N. Washburn, Allston, Mass.
- 357,162. Cable railway—C. Wise, Kansas City, Mo.
- 356,987. Elevated railway—W. R. Cole & J. E. Wyman, Detroit, Mich.
- 356,799. Railway joint protector or brace—D. C. Snyder & C. J. Hoteling, Nevada, Iowa.
- 357,263. Car starter and brake—R. B. Avery, New York.
- 357,516. Electro magnetic attraction device for car—J. B. Atwater, Chicago, Ill.
- 357,532. Cast iron brace chair for street railway rails—O. W. Meysenburg, St. Louis, Mo.
- 357,301. Construction of railways—J. J. Anderson, Chicago.
- 357,759. Car starter—T. Butler & A. Ligibel, Jersey City.
- 357,827. Derailing and replacing attachment for street cars—A. F. B. Hennig & A. Rettig, Denver, Colo.
- 357,800. Safety guard for railway cars—E. A. Wescott, Minneapolis, Minn.
- 357,811. Running gear for railway cars—G. M. Brill, Philadelphia, Pa.
- 357,723. Cable railway apparatus—H. W. McNeill, Oskaloosa, Iowa.
- 357,704. Railway crossing—W. S. East, Lima, Ohio.
- 357,649. Single track railway—G. W. Wright & R. Roach, Leavenworth, Ind.
- 357,592. Soda motor—A. J. Grafenstatt & W. Tweedie, Minneapolis, Minn.
- 358,160. Covering for traction cables—T. E. McCann, Philadelphia, Pa.
- 358,337. Slack adjuster for car brakes—E. Corson & O. C. Crane, Brooklyn and New York, N. Y.
- 358,382. Car heating and cooling device—A. R. Chisolm, St. Louis, Mo.
- 358,366. Life guard for street cars—A. Rapp, Pullman, Ill.
- 358,129. Operating bells and indicators in street cars, etc.—T. P. Swin & J. L. Carr, Brooklyn, N. Y.
- 358,126. Cable railway structure—C. H. Platt, New York.
- 358,331. Subway structure for city streets—F. N. Blanc, New York, N. Y.
- 358,547. Automatic car brake—W. F. Cummings, Bradford.
- 358,685. Cable railway car—H. W. McNeill, Oskaloosa.
- 358,484. Street car signal—C. F. Rogers, Boston, Mass.
- 358,642. Car starter—B. B. Brady & A. B. McCanna, Chicago, Ill.
- 358,690. Bundle rack for railway cars—D. S. Page, Malden.
- 358,703. Cable grip for cars—D. W. Smith, St. Louis, Mo.
- 358,467. Street indicator for cars—C. H. Miller, Minneapolis, Minn.
- 358,619. Street railway frog—A. J. Moxham, Johnstown, Pa.
- 358,810. Automatic mechanism for straightening railway rails, etc.—A. J. Gustin, Boston, Mass.
- 358,781. Cable railway system—W. I. Ludlow, Cleveland.
- 358,584. Subway for cable railways—C. Vogel & F. Whelan, San Francisco, Cal.
- 358,512. Suspended conductor for electric railways—C. J. Van Depoele, Chicago, Ill.

The Butler and Ligibel car starter (pat. 357,759) is a combination, with an axle for car-wheels, of a drum or cylinder rigidly secured thereon, a friction-clutch adapted to engage said drum or cylinder, a brake-windlass, a connection between the brake-windlass and the friction clutch, a draw-bar, and a connection between the draw-bar and the friction-clutch.

Platt's cable railway structure (pat. 358,126) is a combination, with the rails and transverse yokes or stands therefor, of a tunnel or channel for the cable, constructed of previously-formed slabs or sections arranged end to end lengthwise of the tunnel or channel and at their adjacent ends lapping over the inner sides of the yokes or stands, whereby said slabs or sections are sustained against outward displacement. Various other methods of securing the slabs are specified.



**Improvement in Sand Boxes, for Horse, Cable, and Electric Railways.**

We recently gave an illustrated description of a new sand box, manufactured by the Car Track Friction Appliance Company, of Boston, Mass. The improvement has met with such success—attained through tests and trials on many roads—and is so highly spoken of by the presidents and superintendents of those roads, that we give another new representation thereof, which shows the form of the box more clearly than the former illustration.

The Car Track Friction Appliance Company have been awarded letters patent, bearing dates Jan. 1, 1884, March 2, 1886, May 25, 1886, and Oct. 12, 1886, for improvements in sand boxes, the object of these improvements being to deposit or sprinkle sand, gravel, or salt upon a railway track. The means for accomplishing this are under the control of the driver; the movement and operation of the mechanical appliance are effected by the pressure of the foot. The whole arrangement is one of great simplicity; the device is strong, reliable, and positive in its action.

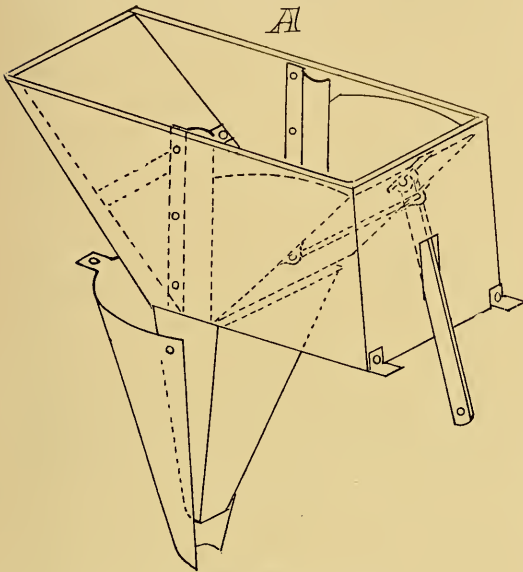

“THE RELIABLE” SAND] BOX.

The appliance consists of a wooden hopper of rectangular shape, with a capacity of from three to four what are termed “stable bucketfuls” of sand. One side of the hopper is oscillating, forming a gate which is made of sheet steel. The other side of the hopper is made of wood, with a steel jaw 6 inches in depth.

The mechanism consists of a short lever from the top of the gate, extending through a hole in the floor about 5 inches, connected with a long rocker lever, hung in the center of the lever by a hanger screwed to the bottom of the floor; on the end of the rocker lever is a rocker pin on which an adjustable socket is placed for the foot of the driver. This socket is capable of being so adjusted that on lengthening it, a wider opening in the box for the discharge of the sand is obtained. By shortening the socket the amount of opening is decreased; this is readily done by the driver merely turning a screw.

The dimensions of the hopper are: Height, 13½ inches; width, 10 inches; length at top, 30 inches; length at bottom, 15 inches. The upper end extends over the wheel box. The gate is kept closed by a strong spring of Bessemer steel.

Reference being made to the cut A, which shows a perspective view of the sand box complete, it will be seen that there is a concave guard on right and left side of the hopper,

a fixed incline, and oscillating incline, a sand shoot, a sand guard, and a vertical lever, connected with a rocker lever, operated by pressure of the foot on an adjustable pin, the amount of opening of the shoot being regulated by the screw upon the adjusting pin. The rocker lever and adjustable pin are not shown in the cut. Wet sand, dry sand, salt, gravel—any of these—can be put into the hopper, and sprinkled upon the track rail just when required by a pressure from the driver's foot.

There is no need of pointing out the advantages obtained from this arrangement; but one of its excellent features is its capability of distributing wet sand or common gravel, or rock salt with as much readiness as common dry sand. For cable and electric railways such a device is singularly appropriate and valuable, as it helps to both stop and start a car, which is not always readily done when the rails are slippery and greasy.

The trouble hitherto experienced in using sand boxes that are made with a tunnel of a circular form has been that only dry sand could be used; and even with this ingredient the choking of the tube or tunnel is of frequent occurrence. Again, the device explained here obviates the crude custom of carrying a pail of sand and a shovel on the front platform.

**Height of Draw Bar.**

The following letter from Mr. Wm. White, the well known president of the Dry Dock, East Broadway & Battery R. R. Co. will be read with interest.

Mr. White's great experience and close observation render his opinion most valuable regarding all street railway matters; and we can not refrain from expressing our gratification that he should approve of Mr. Wright's views regarding the “height of draw bar.”

DRY DOCK, EAST BROADWAY & BATTERY R. R. CO. }  
No. 605 Grand St., NEW YORK, Feb. 23, 1887. }

AUGUSTINE W. WRIGHT, ESQ.:

Dear Sir—I have read your article in the February number of THE STREET RAILWAY GAZETTE on “Height of drawbar” with much interest. Pillsbury's “Best” makes superlative bread. Stephenson's “Best” hardly requires eulogy; at all events no other than it merits.

Theoretical operation of street railways is not of so obvious advantage as the practical application of observed facts to the needs growing out therefrom. It may be that a drawbar, on the line of the car bottom, needs a spring to cure its defects or modify them, so far as a spring may so do. The draft from such a line is certainly defective. On a slight up grade I have seen the front of a car lifted by the team from the rails.

A better, if not the best, line of draft is obtained from a line from the car body floor at the front door to the horses' shoulders, bringing it very nearly to your views, and would be universally adopted if the bracing of the bar to the front platform were not so much in the way. After many years' use, I think the elevated drawbar without a spring preferable to the “Best” at the floor with a spring.

We have about as severe grades as are anywhere surmounted by cars with horses, to-wit: 24 ft. 7 in. in 2200 ft. =1 ft. in 90 feet; 37 ft. 1 in. in 1494 ft. =1 ft. in 40 feet; 31 ft. 9 in. in 2239 ft. =1 ft. in 70 feet. Our one-horse bars are 28 inches from rails. Our two-horse bars are 30 inches from rails, when the elevated bars are used. On one line only we use the bar from bottom of platform 22 inches high. On open cars, 24 inches and 26 inches; length of traces about as in your article.

We only operate 15 open cars in summer. While these each seat 40 persons, I can not admit that the horses doing this work fare worse than those on box cars for the same period. And looking over our horse account I find we average, for past seven years, 1,067 horses; and the renewal of the same to average 18.87 per cent. per annum. This I think will compare favorably with any similar table of work from drawbar at floor level of cars.

I notice, of late, Stephenson places his on top of the bumper, which accounts for the three inch rise.

Yours respectfully, W. WHITE.

### Personal.

MR. CHARLES D. HAINES, of the firm of Haines Bros., New York, was stopping at the Windsor Hotel, Bellaire, Ohio, February 12th, and the Bellaire street railway was knocked off to him that day—it was sold to satisfy the claims of bondholders. The Bellaire *Daily Independent* says: "From what we have seen and learned of the gentlemen (Haines Bros.) they are of that gentlemanly, enterprising class who will benefit a town by their presence and put vigorous blood into anything they undertake. They are engaged in projecting, building, buying and selling street railways, and in securing and dealing in franchises. They now manage and control not less than eighteen or twenty lines in New York, Pennsylvania, Wisconsin and other States, and have just begun to operate in Ohio, having franchises at Steubenville, Portsmouth, Mansfield and maybe other places. Some of these are steam and electricity lines. Mr. Charles Haines informs us that it is their idea to make the road here an entirely new one from one end of the town to the other, and the matter of extending the line up along the river to embrace Martin's Ferry and Bridgeport is contemplated. The gentlemen seem to have unlimited means at their command, and we are heartily glad to welcome them here, if they only give us such a line of street railway as we need."

MR. ALLEN MOORE "is the right man" at the head of the Newton City (Kansas) street railway enterprise, and is much praised: "No better could be found, and he will make it a success."

### Obituary.

JAMES W. FOSHAY, ex-president of the Broadway and Seventh Avenue Railroad Company, died, February 17, at his home, 50 West Fiftieth Street, New York, in which city he was born in 1824. As a youth he was in the employ of Smith & Howe, wholesale grocers; later he became interested in the old Broadway line of omnibuses running from South Ferry to Forty-second street. This interest he sold and subsequently bought into the R. Sands American Circus Company. In 1870 he became president of the Broadway and Seventh Avenue Railroad Company, and held this position until the change of management due to the purchase of stock by the Philadelphia syndicate last year. Since then he has been out of business. His death was due to rheumatism, from which, together with bronchitis, he had suffered for two months. Mr. Foshay was a man of fine presence and appearance. He was tall, erect, and this, with his well-trimmed side whiskers, made him a man of mark upon the street. He was of even temper, always affable, and won the high regard of his associates in business both for his personal qualities and his business methods. He was a man of unusual sensitiveness, and there is little doubt that he suffered keenly in consequence of the action of the District Attorney's office in its course concerning him in the Broadway matter. His wife and his sister survive him. He had no children.

### POINTERS.

#### ALABAMA.

*Birmingham.* The length of the Highland Avenue R.R. is six and a half miles—not two miles, as inadvertently stated in the February Gazette—and the total cost \$65,000 (not \$10,000). This increases the total length of street railways, in operation in the city, to 31½ miles; with a total capital stock of \$327,000.

The Elyton Land Company are proprietors of the Birmingham Water Works, as well as of the Highland Avenue Railroad. H. M. Caldwell is President; and W. J. Milner, Secretary and Treasurer.

The Birmingham Street Railroad Co., and the Birmingham & Pratt Mines Street Railroad Co. have been consolidated. They are laying double tracks in the city and propose to adopt electricity.

A company, with a capital stock of \$20,000, has been organized to manufacture street cars.

*Decatur.* The Decatur Land, Improvement & Furnace Company will build a street railroad 1½ miles long.

*Evansville.* A street railroad company has been organized by Eli Shorter, S. H. Dent and others.

*Gadsden.* The Gadsden Land & Improvement Co., will build a street railroad.

*Selma.* The Selma street railroad has been sold to H. L. McKee and others. The capital stock will be increased and the road extended; dummies will probably be employed. Four miles of 20-pound steel rails and two dummy engines will be required.

#### CALIFORNIA.

*Los Angeles.* The electric street railroad, the opening of which was recorded in our last issue, gives great satisfaction. The Daft motor is used.

The Supervisors will not grant a franchise for the new street railroad, unless bonds are given to ensure its construction.

*San Diego.* The average daily traffic is reported at 2,000 passengers.

*San Francisco.* The Mission st. railroad has been sold. On February 6, the side of a grip car on the Geary street cable line was blown out by a dynamite cartridge placed on the track. No one was injured.

It is probable that the City Railroad Co. will change their line to the cable system, and consolidate with the Market street line.

Col. C. F. Crocker, one of the principal shareholders of the Pacific Improvement company states positively that that company has purchased the City Railroad, and has also secured controlling interests in the Geary street cable line and Central Railroad, which operates the Turk street line.

*San Jose.* The San Jose & Santa Clara Cable Railroad Company has been incorporated to build and operate a cable street railroad from Santa Clara to Alum Rock, 10 miles. Capital stock, \$250,000. Secretary, T. S. Montgomery, of San Jose; Directors, J. M. Thompson, San Francisco; H. M. Leonard, Santa Clara; W. P. Dougherty, L. R. Mills and T. S. Montgomery, all of San Jose.

#### COLORADO.

*Denver.* The Denver Electric Railroad Company has completed and opened the extension between Capitol Hill and the Highlands.

The Colfax Avenue Railroad Company has been incorporated, with a capital of \$25,000, by H. B. Chamberlin, Thomas S. Hayden, Milo B. Smith and others.

#### DELAWARE.

*Wilmington.* The Wilmington City Passenger Railroad Company has agreed to build the line from Tenth and Market streets to Riverview cemetery, for the construction of which line the Wilmington & Brandywine Passenger Railroad Company was recently organized. The new company will abandon its project.

#### FLORIDA.

*Jacksonville.* The Pine Street Railroad Co. proposes to adopt an electric system. H. S. Ely, manager.

*Pensacola.* The formal transfer of the Pensacola Street Railway property was made March 1st, when the balance of \$16,000 was paid.

*Tampa.* A street railroad is proposed. J. B. Wall, H. A. Fuller, Solon A. Turman and others are organizing a company.

#### GEORGIA.

*Atlanta.* The Metropolitan Street Railroad Co. proposes to operate its cars by electricity.

The Van Depoele electric system is contemplated for the Metropolitan Street Railroad, J. W. Rankin, President.

*Augusta.* The Augusta & Summerfield Street Railroad Co. will considerably extend its lines.

*Macon.* The improvements which have put the street railroads into uniform good condition, are due to Mr. John T. Voss, Superintendent of the City & Suburban Street Railroad Company.

*Rome.* The Rome City Street Railroad Company has been granted a franchise. Strap rails to be used on bridges, and the company to take up and relay its tracks for repairs



to water mains, sewers, etc. The road to be completed within one year from May. Messrs. Hill and Dayton own the franchise, and the line was laid out by Mr. Samuel McElroy, C. E., of Brooklyn, N. Y.

## ILLINOIS.

*Chicago.* President C. T. Yerkes, North Chicago Street Railroad Co., has kept his opponents active, the past month—in the city, in the county, in the state, and at the Capitol—and the newspapers have devoted much space discussing his projects, pro and con. The City Council had his application under consideration, Feb. 14th, for a right of way on certain South Side streets, in connection with the North Side cable system, the progress of which was reported in our last number. An ordinance was also presented, at the same time, for new double tracks on the North Side, extending to Milwaukee Avenue, on the West Side. The consent of a majority of the property owners had already been obtained. In fact the project to unite the North and West sides together is a welcomed step towards supplying a much-felt want. But determined opposition has arisen in connection with the much-coveted Dearborn street. The ordinance for the South Side loop extension was formally presented to the Council, Feb. 21st; and was ultimately referred to the Committee on Railroads.

In his petition accompanying the ordinance President Yerkes says, although he was advised it might not be necessary under the law as now construed that the company should have secured the consent of a majority of the property-owners on the several streets, yet the ordinance was accompanied with the petition of property-owners on the respective streets. It was not the intention of the company to ask for the right to lay its tracks on any street where the majority of frontage did not petition the Council to grant such right, and wherever such majority was not obtained, the passage of that portion of the ordinance relating to said street would not be asked. It was the desire of the property-owners on Dearborn street that the company would either construct the bridge which was contemplated to be built at Wells street at Dearborn street, or remove the present bridge from Wells street and place it in position at Dearborn street when the new Wells street bridge should be built. The company had agreed to comply with this request, provided the Council would pass the ordinance, two ordinances being presented covering each of the two plans. The company was prepared to accept either alteration, but the decision was with the Council. He directed attention to the fact that the main feature of the ordinance had in view the establishment of a system of loops which should free the centre of the city from the nuisance of standing cars. The ordinance provides for the use of either animal power or cables; in the case of the latter, the slot not to exceed five-eighths of an inch. Where cable cars are run not exceeding two cars and a grappling car are to be attached together. The cars are to be constructed "with all the latest improvements for the comfort and convenience of the passengers." The tracks must be completed before July 1, 1888, except Dearborn street, between Michigan and Lake, which must be put down within six months after the bridge is built. The La Salle street cable cars are to run east on Jackson or Monroe street to Dearborn, and west from Dearborn on Monroe or Randolph. The Dearborn street line is to be operated by animal or cable power. The ordinance contains the usual provisions about keeping in repair the space between the rails—eight feet for a single track and ten for two tracks. A license of \$50 a car is to be paid. A bond of \$50,000. is required for faithful performance of the conditions.

Certain property-owners, and several members of the Board of Trade, object to the proposed loop system. And certain legislators at Springfield are anxious to enact restrictive measures against the advancement of this and other street railway projects. And President Yerkes' "latest objector" is Collector Stone, who, as custodian of the government building, "has laid the matter before the proper authorities" at Washington. The objection urged from this quarter is "that street-cars on Jackson street would seriously interfere with the transferring of the mails. The street is

narrow, and at that point is almost constantly crowded with mail wagons loading and unloading. If Mr. Yerkes' plan should be carried out, there would be car lines on all four sides of the government building."

President Yerkes was present at the meeting of the Committee on Railroads March 2nd, and in explaining what his company wanted Mr. Yerkes said it was almost absolutely necessary that the company be allowed to construct a loop on the South Side, either by running single tracks along LaSalle, Jackson, Dearborn, and Randolph streets, or by substituting Monroe for Jackson. Unless this loop could be had, traffic on La Salle street would be greatly impeded by switching the 125 cars the company proposed running in front of the Board of Trade and Grand Pacific Hotel. It had been suggested that a loop be formed by running up Fourth avenue, but he was opposed to carrying North Side people into that unsavory locality, and he was very sure that the North Side people themselves would resent any such arrangement. Concerning Randolph street, Mr. Yerkes, in reply to a question put by Ald. Gile, said it would be impossible to make any arrangements by which the North Side cars could run over the West Side tracks, as the attorney for the West Side company had decided that the company's charter expressly prohibited any other corporation from using its tracks. However, the North Side tracks could be laid alongside of the West Side tracks in such a way as not to further encroach upon the pavement.

Mr. Yerkes said, also, that his company would commence track-laying in a couple of weeks if the weather permitted. The principal station at Elm and Clark streets was nearly finished and the machinery was going in. The station for running the cable through the tunnel had been commenced at La Salle and Illinois streets. They hoped to complete all the work laid out this summer. The Wells street bridge would be started as soon as the road was running through the tunnel, but work on the Clark street bridge was delayed because they could not get the consent of all the property-owners at the bridge, as is required by law, before work was begun. The Council will have to amend the ordinance, Mr. Yerkes said, or the bridge will not be built, unless those property-owners refusing their assent come around.

The mayor was also informed that the North Chicago Street Railroad Company had ordered the manufacture of the groove rails for tracks in the tunnel, as suggested by the mayor. The rails are flat, flush with the ground, and hold the flange of the car-wheels in a groove too small to catch the wheels of any vehicles. The rails are in general use in the streets of London and Paris, where the mayor obtained his inspiration.

President Yerkes gained "his point," March 4th, as far as the Board of Trade is concerned; that body then adopted the following resolution: Whereas, The North Chicago Street Railroad Company proposes to lay a track on Jackson street, to connect their track on La Salle street with a track on Dearborn street; and whereas, It is necessary for said company to present to the common council the petition of the majority of abutting property-owners on said Jackson street, requesting said council to grant an ordinance authorizing said company to lay said track. Therefore, resolved, that the proper officers of this association be directed to sign the said petition.

The Chicago City Railway Co. obtained an ordinance, Feb. 25th, authorizing the extension of street railways in the South Division. Ald. Kerr asked if the owners of a majority of the frontage on the streets to be occupied had given their consent. Ald. Drew replied that there was no doubt about it. Ald. Kerr was afraid if the company was given the right to lay tracks on Twenty-second street from State to the river, it would play the dog in the manger and there would never be a line on that street to Douglas Park—a line which was needed.

Ald. Gile made an unsuccessful effort to have stricken out a clause allowing the company to use granite in paving between its tracks. Ald. Manierre wanted a provision put in requiring the company to pay half the cost of a bridge over the river at Twenty-second street. When the West Side company asked for a franchise on West Twenty-second

street it could be required to pay the other half. Ald. Colvin and others laughed at the proposition, since the company was not authorized to cross the bridge. When it was, they said, provision could be made about payment for a new bridge when one was demanded. Ald. Kerr tried to get in an amendment so that passengers could get free transfers to the connecting lines of the companies. He intended, he said, at every opportunity to insist that wherever the lines of any company met, transfer tickets should be given in order to accommodate the public.

The ordinance was passed—yeas 31, nays 2—and it provides, *inter alia*, "that the cars of said railway shall be operated only by animal power, except that it shall be lawful for the Chicago City Railway Company at any time, within the term of this ordinance, to adopt its so-called 'cable system' on any or all of the lines herein named." Also (Sec. 5) that "the rate of fare shall not exceed five (5) cents for any distance between Madison street and the terminus of each of said lines, and passengers on the Twenty-second street, Twenty-sixth street, and Thirty-fifth street direct lines shall be transferred either way, to or from any of the north or south lines of said company which they cross, without additional fare." The grant is for twenty years.

The Arcade Rapid Transit Railway Co's. ordinance was taken up by the Committee on Railroads, Feb. 25th. Chairman Clarke inquired of Ald. Kerr, sponsor for the ordinance, how the arcade was to be laid when there were already an eight-inch water pipe, a three-foot sewer, and seven large gas mains in the street, to say nothing of an intersecting system on cross streets. Mr. Kerr said he was not an engineer, but that the engineer who drew the plans had told him that all the engineering problems had been solved. He therefore proceeded to read opinions by Wagner, Hering, and other experts to show that the foundations of large buildings would not be affected if the work was well done.

This underground project came before the Committee again March 2nd. The ordinance provides for a right of way, along Monroe street, from Michigan avenue west to the city limits. City-Engineer Artingstall said the scheme was perfectly practicable, but would involve big expense in reorganizing the sewage system, Monroe street being the summit of the sewer pipes now laid. Duplicate pipes would have to be laid on both sides of the street or the drainage of that section between Monroe street and Kinzie street would be entirely cut off. C. H. Crawford, representing the company, said that all would be done without any expense to the city. Chairman Clarke thought a sufficient bond should be given to indemnify the city against all loss. Another serious objection, Mr. Artingstall pointed out, was that the ordinance enabled the company to interfere with navigation while tunneling under the river. The tunneling, he said, could be bored without in any way hindering the movement of vessels, and he recommended that the clause in the ordinance relating to the river be changed. Ald. Simons, who was there in the interest of property-owners, said it was the prevailing opinion that the arcade could not be constructed without endangering the foundations of costly buildings, but he would interpose no serious objections until he had investigated the matter more fully.

On motion of Ald. Gile, the ordinance was referred to the Commissioner of Public Works, with instructions to prepare an opinion as to whether or not the project can be carried out without loss to the city.

The Chicago Passenger Railway Co. held their annual meeting March 2nd, 9,065 of the 10,000 shares being represented. H. T. Weeks, E. R. Bliss, Francis Adams, D. L. Hough, and H. P. Peabody were elected directors. Up to January, the earnings of the Adams and Harrison street lines increased 60 per cent. Statements relating to the new Washington street and Centre avenue lines were satisfactory. The total net earnings were sufficient to pay the interest on \$400,000 bonds, purchase between 200 and 300 horses and thirty-five cars, and build the new line, a small surplus being left. The winter traffic was good. A dividend of 10 per cent. was declared. The company owns 120 cars and 600 horses, and the net earnings are about \$350 a day.

The Chicago West Division Railway Company is getting ready to come to the council for an ordinance allowing it to lay tracks on a north and south street, west of Ashland avenue—possibly Wood or Paulina street. The necessary petitions have been signed, it is said, and if the council acts promptly in the matter, the promise is that the added line will be in operation the coming fall. The plan of running the new line contemplates the giving of transfers from and to all connecting lines, which can not fail to be of great advantage to a large class of the company's patrons.

**Decatur.** The Decatur & North Park Street Railway Company was incorporated Feb. 21st; capital stock, \$25,000; incorporators, Milton Johnson, John R. Miller, Michael Elson, Thomas A. Pritchett, and W. H. Acuff.

**Jefferson.** The Board of Trustees have granted the Chicago West Division Railway Company permission to experiment with electricity, as a motor, on California and Armitage avenues.

**Olney.** The Olney City Street Railway Company was incorporated Feb. 25th; capital stock, \$10,000; incorporators, H. M. Hall, William Bowen, E. S. Wilson, Charles Ferriman, Aden Knopf, Thomas Tippit and W. F. Beck.

#### INDIANA.

**Fort Wayne.** Chas. E. Bond filed an application in the Circuit Court, March 7th, for the appointment of a receiver for the property and franchise of the Citizens' Street Railroad Company, making a formal demand for \$30,000. The document cites the company is now insolvent, and urges that the facilities of the company are not sufficient to give the property an earning capacity, and recites the necessity for needed improvements, for which it has no funds or means of creating any.

#### IOWA.

**Council Bluffs.** The Lake Manawa Railway Company, composed of local capitalists, which is financially very strong, will soon advertise for bids for the construction of a new street railway (from 3 to 5 miles long) from the dummy line depot to Lake Manawa (the city's pleasure resort). The charter has been granted, and articles of incorporation have been filed. The line is to be constructed at once. The T rail is to be used, and part of the line is to be operated by horses, and the remainder by a motor. Several other "street tramways" are projected; and one hundred dump tramway cars for horse motive power will be required during this month.

#### KANSAS.

**Coolidge.** A street railroad is to be built to Trail City, Col. **El Dorado.** The El Dorado City Railroad Co. has been incorporated with a capital stock of \$60,000.

**Greensburg.** The Greensburg Street Railroad Co. has been incorporated by G. W. Melville, J. P. Rice, C. J. Neal and others; the capital stock is \$100,000.

**Hartland.** A street railroad is to be built.

**Hutchinson.** Work on the laying of track for the new street railroad was commenced Feb. 15.

**Junction City.** The Junction City & Fort Riley Street Railway Co. has been incorporated.

**Newton.** The Newton City Street Railroad Company has a capital stock of \$60,000. Ninety days is the limit allowed for the laying of the street railway lines to extend throughout Main, Broadway and West Twelfth.

#### KENTUCKY.

**Covington.** A street car tie-up was accomplished in this city, Feb. 23d, thusly: President Abbott received the following document early in the morning:

"To the President of the South Covington and Cincinnati Street Railway Co.:

"We, employees of said company, do hereby demand that we receive a more satisfactory answer to our request by 10 o'clock Wednesday, February 23, 1887, or we will run our cars in the barn." This was signed by nearly all the drivers. No reply was given to this within the specified time, and at 10 o'clock the men, seeing that the communication had been without effect, and that the company intended to refuse their demand, began abandoning their cars in the vicinity of the ticket office. In a short time all the cars stood in proces-



sion at the rendezvous, whence they were run into the stables by some of the clerks at the office. The demand of the drivers was that twelve hours shall constitute a day's work instead of fifteen, as at present, and that they be paid \$2 per day, with payment pro rata for all extra hours. The men have been getting \$2.25 and \$2.40 under the fifteen hour system. This strike ended happily, through the mediation of Mayor Athey; and it is mutually agreed that (1) twelve hours shall be a day's work, and (2) that the wages of drivers of all divisions shall be \$1.80 per day with 15 cents, for each extra hour and a proportionate part for each additional quarter of an hour.

*Lexington.* The drivers on Lexington street cars struck, March 1st, for \$1.50 a day (of sixteen hours) instead of \$1.15.

#### MAINE.

*Bangor.* An electric street railroad is to be built by F. M. Loughton and F. H. Clergue; the Sprague system is proposed.

*Biddeford.* The Biddeford & Saco Horse Railroad Co. has been incorporated by Stephen F. Shaw, Charles H. Prescott, Charles A. Moody, and others. Capital stock, \$50,000.

*Calais.* A street railway is projected by E. F. DeCamp (New York) and others.

#### MASSACHUSETTS.

*Arlington.* A street railroad is projected from the Center to the heights. J. T. White and F. H. Holmes are interested.

*Boston.* The South Boston Street Railway Company have petitioned for location of tracks in South Boston.

The Metropolitan Railroad Company have also petitioned for locations in certain streets in the city proper, and in South Boston. Orders of notice were made returnable on March 14th.

The petition of the Metropolitan Railroad Company for tracks on West Lenox street, Park and Beacon streets, east of Arlington street, has been opposed by a number of influential citizens and business men who consider these streets too narrow for such location, and a railroad track thereon, would, in their judgment, be a public inconvenience.

The South Boston Street Railway Company presented a petition last year for leave to extend its tracks from Harrison avenue to Washington street, and there connect with tracks of the Metropolitan Company. Alderman Bromwich is bringing this matter to a *pro* or *con*.

A "Co-operative Coach Company" is talked of in South Boston, with a view of competing with the South Boston street railroads. The style of coaches would be similar to those now running on Washington street. It is estimated that new coaches of this description can be obtained for about \$800 each, and twenty-five of these would cost \$20,000. Then 150 horses would be necessary, which could be obtained at \$150 for first-class animals, making them cost about \$22,500. Money has been offered to start this enterprise to over \$14,000. If the par value of the stock was fixed at \$1, this would give every one, no matter how poor, an opportunity to subscribe.

The South Boston Citizens' Association held meetings during the month of February in order to protest against the Metropolitan railroad being granted a location in South Boston.

A petition from the Meigs Elevated Railway Company, asking for permission to locate tracks so as to connect with a proposed line to Cambridge, will probably be favorably received by the Boston city government. A committee consisting of some members of the board of aldermen have inspected the system which is to be seen in practical operation at Cambridge.

February 12th was a gala day for horse railroad shares. Cambridge rose to 130, a net gain of twenty-three points for the week. Metropolitan sold two points lower, to 118.

It is claimed that the plans for consolidation of the Cambridge and Metropolitan roads, mentioned in the January GAZETTE, are practically agreed upon. Metropolitan is willing. The terms of consolidation provide for a capital

of \$4,000,000 for the consolidated company. Cambridge stockholders will receive \$1,500,000, and the present Metropolitan stockholders \$2,500,000. In other words, every four shares of Cambridge (par value \$400) will receive three new consolidated shares (par value \$300). Every eight shares of present Metropolitan (par value \$400) will be exchanged for \$500 of the new or consolidated stock.

*Chicopee.* The Chicopee Street Railroad Co. has been incorporated by Haines Bros., of New York, and J. B. Wood, George S. Taylor, J. W. Cunnock, Frank H. Morton, of Chicopee, and George W. Stetson, of New York. Capital stock, \$25,000. The line has been surveyed by R. S. Brown, of New York. Connection will be made with the Springfield street railroad.

*Framingham.* The Framingham Street Railway Company has been organized, with \$35,000 capital. This stock is subscribed principally by Messrs. Charles D. Haines, R. S. Brown, G. W. Stetson, Andrew G. Haines, and F. W. Stanley—all of New York City—who hold 335 shares; while the principal Framingham stockholders—Messrs. S. B. Bird, L. F. Childs, C. Folger, and C. H. Emerson—represent 9 shares. The length of this line is to be about four miles; its gauge will be 4 feet 8½ inches.

The Framingham Center Street Railway Company has also been incorporated, with \$20,000 capital stock; Messrs. Wm. H. Hastings, Wm. C. Wight, Sydney A. Phillips, Charles C. Stevens, Willis M. Ranney, G. H. Waterman, and G. E. Cutler—all of Framingham—forming the preliminary Board of Directors. This line is to be about two and one-fourth miles long; gauge 4 feet 8½ inches.

*Lowell.* The Lowell & Dracut Street Railroad Company will begin work as soon as the weather permits on the line from River street to Roger's Fort Hill, and the Pawtucketville extension will then be built. Five open cars, three closed cars and 165 tons of rails are to be contracted for.

*Malden.* The Stoneham Horse Railroad Co. has petitioned for authority to extend its tracks through certain streets to the Everett line.

*Medford.* The Boston Consolidated Street Railroad Co. will build a line to West Medford.

*Springfield.* The aldermen have granted a location to the West line of the Springfield Street Railroad Co.

*Taunton.* The Scadding Street Railroad Co. have been granted a franchise for a line 3½ miles long to the proposed summer resort at Scadding's Pond. The Taunton Street Railroad Company opposed the application.

#### MICHIGAN.

*Grand Rapids.* The Street Railway Construction Co. has petitioned for power to build on certain streets, having made arrangements with the street railroad company.

*Muskegon.* There are now six cars in operation on the street railway.

*Pontiac.* An electric railway will probably be constructed between this city and the asylum.

#### MINNESOTA.

*Minneapolis.* The city has refused to grant a franchise to the Minneapolis Street Railway Co. for a line from Thirty-first street to the city line. It is recommended that a line be built on Franklin avenue, and the Washington avenue line extended.

*St. Paul.* The contracts will soon be let for the construction of the new cable road. The St. Anthony Hill line is to be in operation this year.

#### MISSISSIPPI.

*Columbus.* The Columbus Street Railway company was permanently organized March 4th, all the capital stock having been previously subscribed, and the project is very popular. Capt. R. W. Banks was elected president and Hon. E. T. Sykes secretary and treasurer. The directors are R. W. Banks, E. T. Skyes and G. W. Cox. The charter and right of way through the streets have been secured and the officers say the road will be built at once.

*Greenville.* The Greenville Street Railway Co. held a meeting, Feb. 14th, for permanent organization, and the following officers were elected: Directors, F. L. Bates, John Gunn, James Burke, G. F. Archer, J. S. Negus; Pres-

ident, F. L. Bates; General Manager, John Gunn; Secretary, J. S. Negus Attorney, J. L. Jayne. Work commenced in earnest, Feb. 14th; the cars are bought, the mules have arrived, and the company expect to have a mile and a half in operation by April 1st. Greenville, says a correspondent, "is expecting a big boom this season, as there are other enterprises to start soon."

*Vicksburg.* The Vicksburg Street Railroad Co., who have now about one and a half miles of road in operation, have issued bonds to the amount of \$75,000, and will this season extend the line about five miles. The track has been laid through the tunnel of the Louisville, New Orleans and Texas Railroad, and it is thought that all trains will be run through it very soon. The rapid caving of the bank near the roadbed, in the vicinity of the Refuge Mill, may possibly make it necessary for the company to use the tunnel.

#### MISSOURI.

*Independence.* A street-car line is proposed for this rising city—elevated by "the arm of geographical destiny." Col. L. P. Muir is one of the promoters.

*Jefferson City.* A company with a capital stock of \$100,000 has been organized to build street railways.

*Kansas City.* The Vine Street Railroad Co. has received its franchise. The road is to be begun in six months, and nonetheless steam or electric motors are to be used. Wm. Anderson, Thomas S. Bugby and Richard Gentry.

The Kansas City Electric Street Railway Co. has been encouraged by the recent successful trials of the cars to attempt regular runs of the cars. The line of the road is from the corner of Fifth street and Grand avenue, directly east to Lydia avenue. One train will be run at first, but the company expects to put on four trains as soon as possible. Each train will consist of the motor car and a passenger car. The motor car will carry thirty-six passengers, and the passenger car about the same number. Each car will be in charge of a conductor and "motorneer." The speed will be about seven miles an hour. The cars can be stopped within a distance of six feet if necessary. Brakes will be used on the wheel, and the motor itself can be made to act as a brake by reversing its motion.

The electricity used by the company is generated at the engine-house on Fifth street near Forest avenue. It is conveyed to the motor in the car by a wire running along the street directly over the road. It is supported by means of steel wires, connecting poles on the opposite sides of the street. From this overhead wire the electricity is carried to the motor by a wire with an arrangement of wheels at the end in contact with the overhead wire that allows it to run along the wire as the car runs along the road. The electricity passes from the short conductor to the fields and armature of the motor, causing the armature to revolve in obedience to the principle of like poles of a magnet repelling and unlike poles attracting. The contact is made by means of copper brushes, which, when touching the armature from one direction of a tangent line, cause the armature to revolve from right to left; from the opposite direction, from left to right. This direction of the brushes is changed by a small lever, which is also used to cut the connection and stop. Another lever is used to tighten or loosen the friction band, which conveys the motion from the revolving armature to the wheel shaft of the car. When the band is the tightest the speed is the highest, and vice versa.

Since the burning of the car shed the cars have had to be repainted and new wire wound on the motors. Two-car trains are to be run. The electric line on E. Fifth street will, however, soon be in operation, and extensions are already projected.

*St. Joseph.* The Union Street Railroad Co. has applied for power to use electricity. A syndicate proposes to buy the other two horse railroads and convert them to the cable system.

*St. Louis.* Of the two bills for street railroads on Grand avenue, only the Walsh bill has been reported to the House.

The Central Elevated Railroad Co. has been granted a franchise. The incorporators are Wm. D. Griswold, J. M. Thomson, Fred A. Wann and others. Capital stock,

\$1,500,000. The line will be  $4\frac{1}{2}$  miles long, double track, with depots every five blocks; uniform fare of 5 cents; 5 minute headway for trains. Electricity or cable traction will be adopted.

Mr. Maffitt, of the Missouri Street Railway Co., states that the company is about ready to begin work putting down a cable on the Olive street line. In all probability, the work will commence in May. The system will be the same as that used on Tenth avenue, New York City.

It is reported that the Boston syndicate that recently purchased the Minneapolis street railroad system proposed to purchase lines in St. Louis.

*Wellington.* The stockholders of the Wellington Street Railway Co. have elected the following board of directors for the year: D. A. Espy, J. W. Davis, D. P. Alexander, J. W. Haughey, D. Brunswick, A. H. Smith and John G. Woods. The board subsequently organized by electing D. A. Espy, president, and J. W. Davis, secretary. It was also resolved that the street railway be bonded.

#### NEBRASKA.

*Hastings.* The vote for street railroads resulted in a majority of 449 in favor. Two miles will be built this season by the Hastings Improvement Co.

*Omaha.* The county commissioners have granted a right of way for a street railroad from Hanscom Place, along Park street to the West Side, to Harrison, Woolly and Ambler. The Omaha Horse Railroad Co. are to work the line, and they guarantee that it shall be built by September 1.

The Omaha Cable Co. has applied for a franchise to build cable street railroads. It is headed by Mr. Fred Gross, of Kansas City, Mo., and is a later company than the Cable Tramway Co., of which Mr. S. R. Johnson is president.

The new street railroad bridge between Omaha and Council Bluffs, to cost \$500,000, will be open for traffic this year.

#### NEW JERSEY.

*Asbury Park.* A syndicate headed by Joseph H. Reall, President of the American Agricultural and Dairy Association, proposes to establish a street railroad. The founder, James A. Bradley, raises strong objections, but the residents favor the scheme.

*Garfield.* A street railroad is projected to connect with Paterson.

#### NEW YORK.

*Brooklyn.* The Union Elevated Railroad Company, which has already given an earnest of its intentions by erecting a little of its structure at Fulton Street and Flatbush Ave., and at Flatbush and Atlantic aves., where its routes cross those of other companies, proposes to push its work in all parts of the city as soon as spring opens. The sum of \$1,000,000 has been raised, and the company proposes to pay upon a cash basis for the work. It will be pushed simultaneously, says General Wingate, counsel of the company, in Broadway, Myrtle Ave., Flatbush and Fifth aves., and Fulton St., if the company gets the right to build in that thoroughfare.

*Huntington.* The Huntington Street Railroad Company has been incorporated by Douglas Conklin, of Huntington, L. I., Richard G. Phelps, of Brooklyn, and others; capital stock, \$30,000. The line will be three miles long, from Huntington station on the Long Island R. R., to the east side of the harbor.

*Kinderhook.* A street railroad is projected from Kinderhook to Niverville, through Valatic; Haines Brothers are interested.

*New York.* Handsome new Pullman horse cars of the Broadway and Seventh Ave. line pattern, with high windows and of orange color, have appeared in Fourteenth St., running west from Union Square. They are a great improvement on the old car, even though bob-tailed and run by one horse.

A preliminary test of the cable which is to propel street cars in Park Ave., from Washington Ave. to Broadway, was made March 2nd. The power was supplied by a 250 horse-power engine at Grand and Park aves., and the cable was



run at eight and one half miles an hour. The cars will not be attached to it for a week or ten days.

The Safety Electric Light and Power Company has been incorporated, with a capital stock of \$250,000. The trustees are George W. Jones, of this city; Henry H. Kerr and Walter C. Kerr, of Brooklyn, and Caleb H. Jackson and Herman H. Westinghouse, of Pittsburgh.

The Sixth Avenue Surface Railroad Company asked the Aldermen for permission to extend its tracks. One branch is to go from Varick St., through Clarkson St. to the Hudson River at West St., with double tracks; the other branch, from Varick St., through Watt St. to the Hudson River, at West St., also with double tracks. This was referred to the Committee on Railroads.

The Sixth Avenue Railroad Company, at their annual meeting, have re-elected all the old board of directors, as follows: Samuel Thorne, T. P. Olcott, Frank Curtiss, A. R. VanNest, Henry Demarest, William Bryce, William Y. Mortimer, Albert W. Green, Theodore E. Macy, Abijah Curtiss, Charles G. Landon, Henry S. Moore, and Edward Weston.

The Julien Electric Motor that has been making a series of experiments on the Eighth Avenue Street Car Line for several months, had a public test March 4th. The motor ran from the stables at Forty-ninth St. and Eighth Ave. to One hundred and tenth St. and back, a distance of about five miles, in forty-five minutes. Fully twenty persons were in the car, among them President Lyon, of the Third Avenue road, Francis Pares Osborne, W. A. Harper, William A. Bracken, president of the Julien Company, George E. Montgomery, and Dr. Brooks H. Wells. The car was under the management of Engineer Kohl, who was connected with Julien's factory in Paris. It moved smoothly from the depot, crossing the switches without difficulty, and ran along the track at a speed about equal to the highest rate of surface cars. President Lyon watched its progress with interest and expressed himself well satisfied with the trial. The engineer showed that he could easily stop the cars within an extremely short distance. In running down grades the motor was checked and the car glided along on its own momentum. In answer to inquiries President Bracken said that the greatest difficulty experienced had been the rough road and uneven gauge of the Eighth Ave. track. A machine car to work entirely satisfactorily needs a perfect track. As it is, he said, the motor could be used at a cost of less than \$4 a day, while surface cars in the city cost more than \$7 a day. The officers of the Arcade road made a trip on this motor, last week in February, and were well pleased with it.

#### NORTH CAROLINA.

*Raleigh.* The Raleigh Street Railroad Company will extend its road.

#### OHIO.

*Cincinnati.* A bill has been drafted by J. J. Miller, for the organization of elevated railroad companies. Minimum incorporators, five; duplicate sets of maps, plans and specifications to be filed with the Secretary of State; the Railroad Commission to inspect the route and examine the filed plans and specifications; no steam or smoke to be emitted by the engines; uniform fare of five cents within five miles, one cent per additional half mile; Mr. Joseph Earnshaw, C. E., is interested.

The Cincinnati Street Railroad Company has increased its capital stock from \$4,500,000 to \$5,000,000.

The Mount Adams and Eden Park Inclined Railway Company, will make the Oak street line an electric road as an experiment.

*Cleveland.* The Brooklyn Street Railroad Company has been directed to run its cars to Woodland avenue.

The street railroad companies are to be required to heat their cars.

*Mansfield.* The franchise for an electric street railroad has been granted to I. T. Durham.

*Youngstown.* On Feb. 11, a switch engine of the N. Y., P. & O. R.R., ran into a street car at West Lake crossing, hurling it to a distance. The driver sustained concussion of the brain, and of the three passengers, two were fatally injured, and one escaped with a few bruises. It is reported

that the driver thought he could clear the track in time and the engineer stated that owing to the smoke he did not see the car.

#### PENNSYLVANIA.

*Norristown.* The Citizens' Passenger Railroad Company is a new corporation. It will build its line in the spring.

*Philadelphia.* A horse drawing a coupe got its shoe caught in the slot of the Tractor Company's conduit, and injured its leg so badly that the horse had to be shot. The company claimed that it was not responsible as the slot was necessary for the operation of the cars. The jury gave the owner of the horse a verdict for \$211.

The underground railway ordinance is now to be considered by the general committee of City Council and a strong effort will be made to have the bill passed. The motive power will be electricity, and each car in the train will seat thirty-eight persons, the doors being on the side. The rate of speed is to be thirty miles an hour, stations to be three to the mile in resident portions of the city, and four to the mile in business portions. This rate will enable trains to accomplish twenty miles an hour, allowing the difference for stops, which is almost double the speed of the elevated roads in New York. The tracks will be double, and there will be no switching between stations, which are to be inclosed. The building in each case is entered from the street, and a decent is made to the platform immediately beneath the pavement. Ventilation is fully provided for, and, in addition to the moving of trains, the subway is designed for the housing of all classes of pipes and wires.

*Pittsburgh.* A bill has been introduced to combine all the street railroads in Pittsburgh and Allegheny under one management. There is vigorous opposition. It is proposed to alter them all to the cable system. The Pittsburgh, Allegheny & Manchester Street Railroad Co. has refused to lease its line to the syndicate who are pushing the bill, but will operate by cable independently.

The new cable railroad will be in operation by November, work is to be commenced at once at Oakland.

#### TENNESSEE.

*Chattanooga.* The Chattanooga Street Railroad Co. will extend the line to Blowing Springs.

*Dayton.* A street railroad company, capital \$150,000, has been organized by W. G. Allen, S. B. Northup and others. The road will be built in the summer.

*Murfreesboro.* A company has been organized to build a street railroad.

*Nashville.* The Chancellor has overruled the motion of the Mayor and Council to dissolve the injunction, he says: "The city can not now by violence take away from the Fatherland Street Railroad Co., that which it deliberately granted to it, or rather that which the State granted by the express concurrence of the city." The bridge suit is therefore decided against the corporation, and the Fatherland Street Railroad Co. and the Nashville and Edgefield Railroad Co., which own the bridge tracks jointly, are successful.

The Main Street and Lischey Street Railroad Co. has filed an amendment to its charter for an extension of the franchise.

#### TEXAS.

*Dallas.* The Belt Street Railroad Company and the Commerce & Ervay Street Railroad Company have been consolidated and will probably extend their lines.

The North Dallas Railway Co., organized Feb. 15; Capital stock \$50,000; will commence building in 15 days, and will run with dummy or steam street cars 4 miles of road. Incorporators: Franklin Priest, of Ill.; John H. Cole, Dallas; Wm. Hunstable, Dallas; W. A. Disborough, of the Union line, Philadelphia, late of Penn. R. R. N. Y. Officers: F. Priest, president; John H. Cole, vice-president; Wm. Hunstable, secretary; O. P. Bowser (of Bowser & Lennon), treasurer; and W. A. Disborough, general manager. Office of president and manager, 818 Wood street.

*Weatherford.* The Weatherford Street Railroad Company, capital stock \$50,000, has been incorporated by G. J. M. Borril, J. L. Simmons and O. H. Milliken.

## VIRGINIA.

*Richmond.* The Richmond City Railroad Co. will soon begin work on the extension.

## WEST VIRGINIA.

*Wheeling.* The Citizens' Street Railroad Co. will extend the line to Benwood.

## WISCONSIN.

*Appleton.* The Appleton Electric Street Railroad Company, will purchase two or three open cars for the summer, and will considerably extend the line. Its operation is very satisfactory.

*Eau Claire.* The abandoned street railroad tract from the south part of the city, half a mile long, is to be re-opened and extended. This is on the east side of the Chippewa river, the track on the west side will be extended a mile north.

## FOREIGN.

*Canada.* Montreal wants an electric street railroad.

*Glasgow (Scotland).* The Glasgow Tramways and Omnibus Company has completed the reconstruction of the car shed and stables at Crownpoint, which were destroyed by fire; five tenements for the company's workmen have also been erected. Total cost of buildings, \$50,000. The company has applied to Parliament for power to operate its lines by electricity.

THE NEW ALBANY ROLLING MILL COMPANY has more orders for rails, for cable roads, than they can execute. "They received an order from the Cable Railroad Company of Philadelphia for 5,000 steel yokes, which order had to be declined for the present on account of the large orders ahead of it. The rail-mill company are now turning out a large order for steel yokes for the North Chicago Cable Company, as well as a large lot of the new-style T steel cable rails. These rails are something new and very superior for cable roads, and the yokes being made for the North Chicago are much heavier than those made by the rail-mill company for the St. Louis cable road. Seven new furnaces are nearly ready for firing at the rail-mill."

## Business Notes.

*Chicago, Milwaukee & St. Paul Railway.*—(General Passenger Department.) MILWAUKEE, Wis., March 1st, 1887.

*Circular.*—Mr. John O'Laughlin is this date appointed Traveling Passenger Agent of this company, with headquarters at No. 98 North High Street, Columbus, Ohio, to succeed Mr. Joseph A. Webb, who has resigned to go into other business at Columbus, Ohio. Mr. O'Laughlin's district includes the States of Ohio (except on the lines of the Lake Shore & Michigan Southern and New York, Chicago & St. Louis R'ys), West Virginia and Virginia, and the cities of Washington, D. C., and Baltimore, Md.

A. V. H. Carpenter, Gen'l Pass. and Ticket Agent;  
Geo. H. Heafford, Asst. Gen'l Pass. and Ticket Agent.

MR. GEORGE F. KEEP, superintendent of the Natick & Cochituate Street Railway Company, writes the Car Track Friction Appliance Company, Boston, Mass.: "I have used your Reliable Sand Boxes five weeks; they are working well. I would not be without them for twice what they cost."

PULLMAN'S PALACE CAR COMPANY have the following among their recent orders: Eight grip cars, together with ten closed and twelve cars, for the St. Louis Cable & Western Railway Company; four cars for electric railway, Lima, Ohio; five cars for Milwaukee City Railway Co.; ten cars for Rochester City & Brighton R. R. Co., Rochester; and ten cars for the Metropolitan Cable Railway Co., Kansas City. The foregoing being built at Pullman. Also, at Detroit shops, electric passenger and motor cars for the Highland Park Railway Co., Detroit.

THE BALTIMORE CAR WHEEL CO. are preparing gear for forty-five street cars built by the Brownell & Wight Car Co., St. Louis, twenty being for the Jefferson Avenue Railway and twenty-five for the Mound City line, St. Louis; also, for twenty-four cars built by the John Stephenson Company (Limited) New York, twelve of them being for the Metropolitan Railway, Washington, D. C., and twelve for the Essex Passenger Railway, New Jersey.

## J. G. BRILL &amp; CO.,

PHILADELPHIA,

Builders of

## Railway and Tramway Cars.

GOLD MEDAL  
For Best Closed Car  
AT  
CHICAGO EXHIBITION  
OF 1883.



GOLD MEDAL  
For Best Open Car  
AT  
NEW ORLEANS EXHIBITION  
OF 1885.

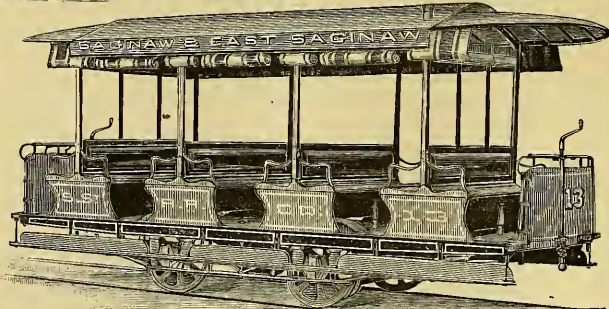
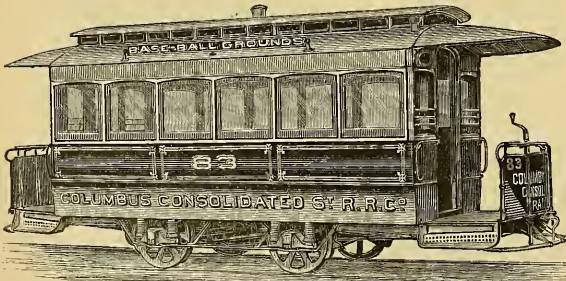



# The Street Railway Gazette.

VOL. II.

CHICAGO

APRIL, 1887.

NEW YORK

No. 4

## Robert Hutchison, Esq.

PRESIDENT OF THE TRAMWAY INSTITUTE, LONDON.

America is indebted to England for many things. Our trans-Atlantic "cousins," on the other hand, owe not a little to the United States, and may take profitable lessons from "Brother Jonathan." This is the case especially with regard to street railways, or tramways. It was shown forcibly by the late Charles Dickens that England should have followed the lead of America, when street railways were "in Train" over there in 1861. But Mr. Train's "omnibus-railways" were refused; and nearly a decade passed before the street railway movement was revived in Great Britain—then under the name of tramways. When the American Street-Railway Association was organized, in 1882, they officially adopted the name "street-railway" for what they call "tramway" across the water. And in 1885 the Tramways Institute of Great Britain and Ireland was organized, the objects of which are stated in another part of this number.

Tramways are now gone "to stay" in England and Wales, Scotland and Ireland.

There is also the Isle of Man Tramways (limited), which are not included in the parliamentary returns of the United Kingdom. And, altogether, there are close upon a thousand miles of street railways in operation, using some 25,000 horses, nearly four thousand cars, and over four hundred and fifty locomotive engines; and they carry about four hundred million passengers in a year. All this has come into existence since the passage of the General Tramways Act in 1870.

Nothing encourages the success of new enterprises in one country so much as their prosperous adoption by a friendly nation. And no doubt we express the sentiment of all cis-Atlantic street railway leaders when we congratulate the successful promoters of British tramways. And the American Street-Railway Association will naturally feel strengthened in their own efforts, when they see the success of the more recently organized Tramway Institute in England.

We have much pleasure in presenting our readers with a portrait and brief biographical sketch of the first President of the Tramway Institute—Mr. Robert Hutchison, of

Caerlowrie, Scotland. Mr. Hutchison was born in Leith, in 1834; of which seaport of Edinburgh his father was provost for six years. He was educated at Edinburgh High School, under Dr. Leonard Schmitz, and at the University of Edinburgh. He is a Justice of the Peace, and a Commissioner of Supply, for the county of Linlithgow, where the family property is situated. He was a director of the National Bank of Scotland for seventeen years, and of the Scottish Union and National Insurance Company.

But what fits Mr. Hutchison specially for the Presidency of the Tramway Institute is his experience as chairman of the Bathgate Railway Co.; and he was the first chairman of the first tramway company in Scotland, having been chosen chairman of the Edinburgh Street Tramways Company, on the passing of their first Act of Incorporation in 1871. He retired from the Board in 1873; but in 1881 he was solicited by a number of large and influential shareholders to rejoin the Board, and he was then re-elected as chairman of the company, to which position he was again unanimously re-elected, on the expiry of his term of office, in January last. The Edinburgh Street is the largest tramway company in Scotland, having a paid-up capital of £360,000 (\$1,753,200), operating over 18 miles of track with 73 cars, 747 horses, and 2 locomotive engines; and during the years 1885-86 they ran 1,234,815 miles, and conveyed 11,234,560 passengers; their net receipts for the year being £24,796 (\$120,757).

Mr. Robert Hutchison is thus highly qualified by experienced personal merits, as well as being connected with the chief Scotch families—he is a cousin of the distinguished

Lord Roseberry—to fill the presidential chair of the Tramway Institute. The proceedings of its first meeting, in London (July 17, 1885), were opened with an address by the subject of this sketch; and, speaking of the progress of the tramway system, Mr. Hutchison said: "I have watched with interest the development of the enterprise north of the Tweed, and was convinced from the very onset that it was probably one of the greatest and most economical social reformations of the age. Like many of the most valuable inventions, its simplicity surprises one that it had not been long ago adopted by our forefathers."



*Yrs faithfully*  
*Robt. Hutchison*

## Construction, Equipment and Maintenance of American Street Railways.

BY AUGUSTINE W. WRIGHT.

(Continued from page 49)

### CHAPTER V.

#### BUILDINGS FOR STREET RAILWAYS.

This subject will be considered under the following heads: Stables and Car houses.

##### STABLES.

The horse railroad companies in the United States employ nearly a hundred thousand horses and mules. No other line of business aggregate such large numbers under the supervision of so few men. Anything affecting the health of these horses is a matter of prime importance to the various owners, and the construction of the stables in which the car horse passes so many hours should receive the careful consideration its importance, measured in dollars, demands. Permit me to quote from a report that I made to the American Street-Railway Association on "Buildings":

"We appeal to you in behalf of the horse, to give him suitable stable quarters; but this we urge upon the score of economy, rather than humanity. No other line of business employs as many horses in the cities and towns of this country, under one management, as the one we represent, namely, horse railroads. About 30% (to 40%) of our operating expenses is expended in the horse department, amounting in the aggregate to a vast sum of money. Anything that will reduce this expenditure, by prolonging the life of the horse, which is now about four years, more or less, is worthy of investigation. Badly constructed stables are responsible for many, very many, of the diseases among horses. The paramount importance of abundant sunlight, perfect sewerage and good ventilation is now, fortunately, recognized almost universally in building human habitations, but how often ignored in providing quarters for the horse, the number sick and unfit for duty, most eloquently testifies. John Stewart wrote, 'Stables have been in use for several hundred years. It might be expected that the experience of so many generations would have made them perfect. They are better than they were some years since. \* \* \* A damp stable produces more evil than a damp house. \* \* \* Since 1788, when James Clarke's work was published, protesting against close stables, there has been a constant outcry against hot, foul stables. Every veterinary writer, who has had to treat of diseases, has blamed the hot stables for producing at least one half of them.'

"Jennings wrote: 'The most desirable thing in a stable is ventilation. A horse requires air equally with his master, and as the latter requires a chimney to his sleeping apartment, so does the former.'

"Henry W. Herbert, better known as Frank Forester, wrote: 'In a climate so uncertain, changeful, and in which the extremes of heat and cold lie so far apart as in this country, the question of stabling is one of paramount importance. The stable, to be of real utility, must be perfectly cool, airy and pervious to the atmosphere in summer; perfectly close, warm, and free from all drafts of external air, except in so far as shall be needed for ventilation, in winter; perfectly ventilated, so as to be pure and free from ill odors, ammoniacal vapors and the like, arising from the urine and excrement of the animal; at all times perfectly dry under foot and well drained, since nothing is more injurious to the horse than to stand up to his heels in wet litter. \* \* \* Lastly, it should be perfectly well lighted, as well as thoroughly aired.'

"Stonehenge wrote: 'The horse, like all the higher animals, requires a constant supply of pure air to renovate his blood; and yet it must not be admitted in a strong draft, blowing directly upon him, or it will chill the surface and give him cold. \* \* \* By common consent, it is allowed that no stable divided into stalls should give to each horse less than 800 or 1000 cubic feet.'

"Youatt wrote: 'It is not generally known, as it shou

be, that the return to a hot stable is quite as dangerous, as the change from a heated atmosphere to a cold and biting air. It is the sudden change of temperature, whether from heat to cold, or from cold to heat, that does the mischief, and yearly destroys a multitude of horses.'

"One more quotation, from John Osgood, who, in speaking of city stables, said: 'Now, in the name of humanity and ordinary commercial thrift and sagacity, let this be stopped! There is no reason why stables should be horse-hells!! No reason why they should vie with the "Black Hole" in their inevitable cruelty, and gloom, and destruction. These, and city stables generally (with some exceptions) are a disgrace and a shame to a civilized community. So long as they continue as they now are, horses must die. There are no remedies for the sudden and violent diseases which attend such poisonous air, and water, and food. The remedy lies in providing ample and well ventilated stables—stables well lighted, with stalls of ample dimensions, with escape pipes for the ammoniacal effluvia which arises from so many animals, and their excretions, with more room for evaporations; and then the chances would no longer be against every horse who passes through these doors, as they were against those ghostly ones who passed through Dante's gate, and as they went in, read above their heads,

"Who passes here, goes into everlasting hell."

Improve the stables then, and prevent disease. \* \* \* Do not insult a respectable animal, who has come from the country to do his share of the work of the world, and has brought with him the memory of the sweet hills and skies at least, by immuring him in one of those cramped, rickety, rotten, stinking, slovenly, damp dungeons, where a dumb beast would lose his self respect and his courage, beneath an oppressive weight of miasma and hideous, gloomy, nasty confusion. Stop this, or pray that horses may die, ere the evil days come.'

"We have quoted thus extensively, to emphasize and impress upon you, if need be, as among the first requirements for your stables, good ventilation, drainage, and abundant light, matters of prime importance in any stable, but much more so in your own, where the horse spends frequently twenty of the twenty-four hours, whereas in other lines of business, he often spends not more than eight hours of the twenty-four in the stable."

##### A NORTH CHICAGO CITY RAILWAY STABLE.

I will now describe a stable built by me for the North Chicago Railway, in which I have attempted to provide the essentials of light, ventilation, drainage, etc. It fronts south 125 feet upon Belden avenue, east 238 feet upon Jay street, both streets being 66 feet in width, along the west side there is a public alley, 16 feet wide, and 50 feet additional vacant ground. On the north there are 12 feet vacant; property of the company. Light and ventilation are therefore obtained from all four sides. (See figure 56.)

The horses face north and south, and in the rear of each row, an alley 10 feet wide extends entirely across the stable, with a sliding sash door at each end 7'x10'. Another alley 9' 6" wide, extends the entire length of the stable at right angles to the first described alleys, with large, sliding sash doors at each end.

The stalls are 9 ft. deep, and each horse is allowed 56 inches of width. Double stalls are, in my opinion preferable, when horses will stand together quietly, but the service of horses on street railways is so comparatively brief, that many teams will not stand quietly together in double stalls, and I therefore alternated a double stall, with two single stalls, thus permitting the foreman to place the horses who do not agree with each other, in single stalls.

The floor of this stable consists of 4 inches of asphalt, having scantlings embedded therein 2"x4", placed on sixteen inch centres, to which a pine floor is spiked. The latter consists of boards surfaced one side, and put in the hot asphalt, which fills every joint and is water tight. A flooring of two inch common plank is placed on top in the stalls, to take the wear. The stalls incline two inches from their head to a gutter in the rear, which connects with a catch basin through suitable traps. These gutters are covered by cast iron plates six inches wide, fifty-six inches long,



perforated to allow the urine to pass into the gutter. These covers are movable, and at least once each week they are all taken up and thoroughly cleansed by scraping and washing, in addition to which some disinfectant should be used.

Between each row of horses there is a "feed-alley" four feet wide. By this construction the horses are not brought head to head, to breathe each the other's breath, contamina-

ted perchance by disease, which is thus spread from one to another. Food is not wasted in placing it in the manger, for it is taken directly from a feed cart in the alley in front of each animal. There is less danger of an employee being injured, or perchance crippled for life, in entering the stall to feed some vicious or frightened horse.

At each end of these feed-alleys windows are placed, containing 32 lights of glass 9" x 14", a size I adopted as a standard, and used whenever possible to avoid carrying a stock of various sizes. In these feed-alleys, beneath the floor, there are placed fresh air ducts extending clear across the stable, from outside to outside, through which fresh air is admitted, passing out into the stable through perforations in its cover, thus avoiding injurious drafts. Its exterior openings are protected by cast iron grates built in the brick work, preventing the entrance of vermin, especially the pestiferous rat. In this stable there are urine ventilators, one located at the intersection of each alley, for the exit of foul air. They are 6' x 6' at the lower end, and taper to 4' x 4' at the top, extending 8' above the roof. The four sides, above the roof, are movable, except the posts, having projecting aprons, inclining at an angle of 45°, thus deflecting the air upward, and doing away with downward currents; permitting the opening to be reduced in cold or inclement weather, ropes extending to the first floor for this purpose. I was indebted to Mr. John Stephenson for the idea of this construction. It resulted from many experiments made by him upon ventilation while a member of the New York School Board. The gas burners located under these ventilators, assist in the ventilation by heating the air, which ascends and warms the outward-bound current of impure air.

VENTILATION.

When first called upon to design the ventilators for a stable, I turned to my engineering library, and consulted book after book, in vain, to ascertain the proper amount of fresh air to provide each horse. I asked engineers, physicians and veterinary surgeons without obtaining the information. The Civil Engineers' and Architects' Journal for 1841, page 103, states: "The Committee of the Academy of Paris to whom the question, 'what is the quantity of air necessary for the healthful respiration of the horse?' was referred by the Minister of War, reported that in a building where the air is properly renewed, and that result is effected by a skillful and efficient system of ventilation, a horse can never suffer so long as he has from 25 to 30 cubic meters of air"—83 to 1060 cubic feet. Upon a previous page I have quoted Stonehenge, who allowed from 800 to 1000 cubic feet per horse, but these statements did not solve the problem; and, desiring to have enough fresh air, I built ventilators as above described, allowing one such

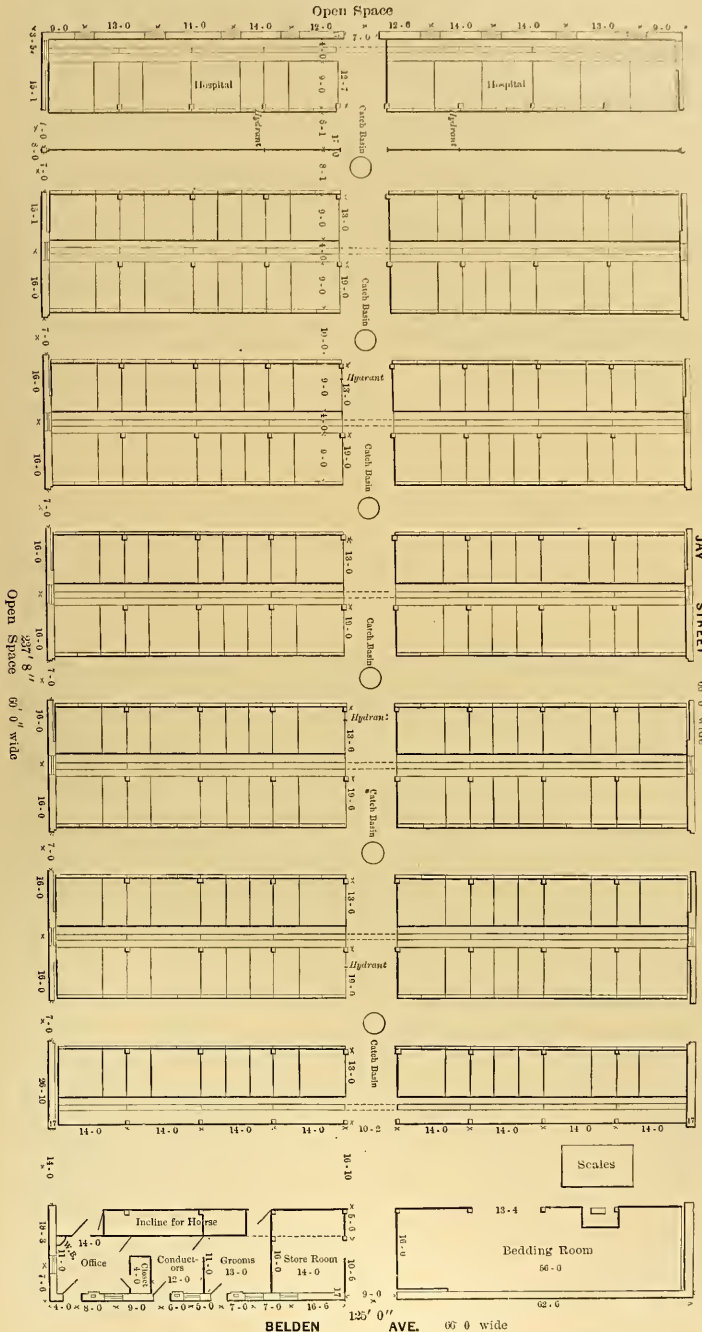

FIG. 56.—GROUND PLAN OF NORTH CHICAGO CITY RAILWAY STABLES.

ventilator for about 40 horses, assuming that air expands  $\frac{1}{450}$  of its volume per degree Fahrenheit, and that it is winter weather, the interior of the stable being 15 degrees warmer than the exterior air—for, in my opinion, the horse enjoys better health if the stable temperature varies only 10 to 20 degrees from the exterior air, than he does in a hot stable—the air inside the stable would lose in weight (the ventilator being 20 feet high)  $\frac{20 \times 1.6}{490} = .612$  feet. That is, it would be lighter than the outside air by the weight of a column of air .612 foot high. The velocity with which the outside air column would try to get in at the base of this shaft would be governed by the same law as that of a body falling through the space of this excess of height. The formula for this velocity is  $V = \sqrt{2gh}$ ,  $g$  representing the force of gravity, here about 32, and  $h$  the height or space through which the fall is made; substituting, we have  $V = \sqrt{8 \times 32 \times .612} = 6.26$  cubic feet per second per square foot of ventilator. We must deduct from this amount the loss by friction of the air against the sides of our ventilator. Being a straight beveled box, with smooth sides, this loss will probably not exceed 0.3 of

hour, or 93.3 per minute. The specific heat of air is 0.238 nearly. A cubic foot of air at 45° F. weighs 552 grains.  $\frac{552}{7000} = .0789$  pounds. The amount of air that would be heated 1° F. by the two burners per hour is  $\frac{93.3 \times 2}{3.33} = 49.701$  cubic feet, which assists in creating a current of air through the ventilator.

Gen. Morin found by experiments the amount of air necessary for the healthful respiration of the horse to be from 5637 to 6263 cubic feet per hour. The English army regulations are said to allow to each horse a space of 1605 cubic feet, 100 square feet of floor, and 2466 cubic feet of air per hour. My practice coincides very closely with the amount found necessary by Gen. Morin, although I was ignorant of his experiment. The health of the North Chicago Railway horses confirms me in the belief that the ventilation of their stables is ample. Mr. Robert Atkins, superintendent of the horse department, reported to me in February, 1885, as follows:—

“The number of horses owned by the North Chicago Ry. Co., at the present time, is 1658; average number owned

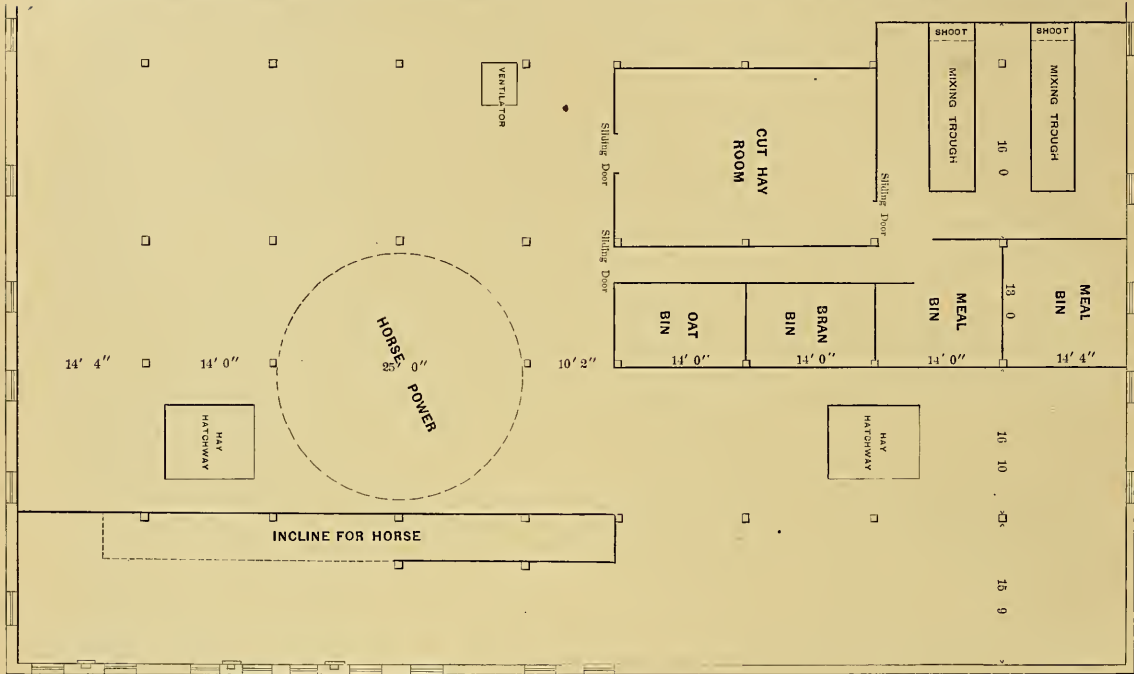

FIG. 58.—FLOOR OF FEED DEPARTMENT.

6.26 cubic feet, say 1.90 cubic feet. Deducting this amount from the former, leaves 4.36 cubic feet, per second per square foot of each ventilator, passing through, and multiplying by 3600, the number of seconds in an hour, and by 16, the number of square feet in the ventilator, and dividing by 40 the number of horses supplied,  $\frac{3600 \times 16 \times 4.36}{40} = 6278.4$  cubic feet of air per hour for each horse, under the conditions assumed.

In summer the doors and windows are open, and as most of my stables have air and also light from four sides, through many openings, there is no trouble about ventilation at that time of year.

I stated that the location of the gas burners, under the ventilators, assisted in the ventilation. The part they perform is as follows: There are two burners, consuming each four cubic feet of gas per hour. The quantity of heat evolved by the combustion of a cubic foot of ordinary illuminating gas, is estimated at 700 heat units. The two burners would therefore evolve  $2 \times 4 \times 700 = 5600$  heat units per

during 1884, 1500. Average number unfit for duty from all causes, 38½; but this includes 150 new horses purchased fresh from the country to operate a new line, who suffered with distemper in being acclimated. Excluding them, the average was 32, or about 2%. Forty-five horses died during the past year—14 from accidental injuries, 10 from colic, 5 from lung fever, 4 from paralysis, and 12 from eight other diseases.

Deducting the 14 from accidents and 10 from colic, leaves 21 deaths only that might have been remotely affected by ventilation—being 1.4%. Surely this experience indicates ample ventilation, and I therefore consider the above construction as quite satisfactory.

Continuing the description of the stable in question: The first story is 16 feet high. Fig. 57 is an interior view looking down the center of the stable. Second story 7 feet at the side walls and 9 feet at the center. Each horse has 1216 cubic feet of space. The hay loft suffices to stow one year's supply of loose hay, besides containing a horse-power and



hay-cutter and feed department. Fig. 58 shows the floor arrangement, and fig. 59 an elevation of this. The latter department contains a number of bins in which the feed is stored, a large room for cut hay, one day's supply at least

The cost of bedding obtained in this way is one half cent per diem per horse.

A hospital should always be provided, where a sick animal can be separated from the others and be as quiet as possible. In this stable it is located at the north end, in the most quiet spot. Here the tubs are placed containing salt water foot baths, in which the horses stand and soak their feet as mentioned in a previous chapter. At this end of the stable the blacksmith shop is located, but without a forge as the horses are shod cold, no heat being permitted.

The entire interior is whitewashed regularly.

Scales are provided upon which supplies are weighed. An office is provided for the foreman, and separate rooms for grooms and conductors, with suitable closets, store rooms, etc.

I think with Youatt that the stable should not be too warm in winter. Nature is a safe guide, and she provides the horse with a suitable covering. The stable temperature should, in my opinion, vary not more than 10° or 20° from the external air. Keep the stable cool and if necessary throw a blanket over the horse while hot, just in from work, during severe winter weather.

The horses passing over twenty hours per diem in the stable, the importance of thorough sanitary arrangements is thereby largely increased.

I believe that horses frequently suffer more from thirst than railway managers are disposed to admit. In this stable numerous watering tubs are provided, and every horse employed by the company is watered during the night, in addition to the day time. Some fine railway stables have been built, containing an arrangement by which each horse has before him a constant supply of fresh water. A decided difference of opinion was manifested upon this question by the members of the American Street-Railway Association.

The following are the specifications for mason work and carpenter work, together with bills of materials therefor, of stable.

Specifications for mason work for North Chicago City Railway Stable, corner of Jay st. and Belden ave.:

The building will be of brick, two stories in height, 125' X 238', as shown in accompanying plans.

The contractor will be strictly held to execute such work and use such materials as are herein-after described, and he must submit in regard to the character of the materials used, and work done, to the judgment of the superintendent.

*To be continued.*

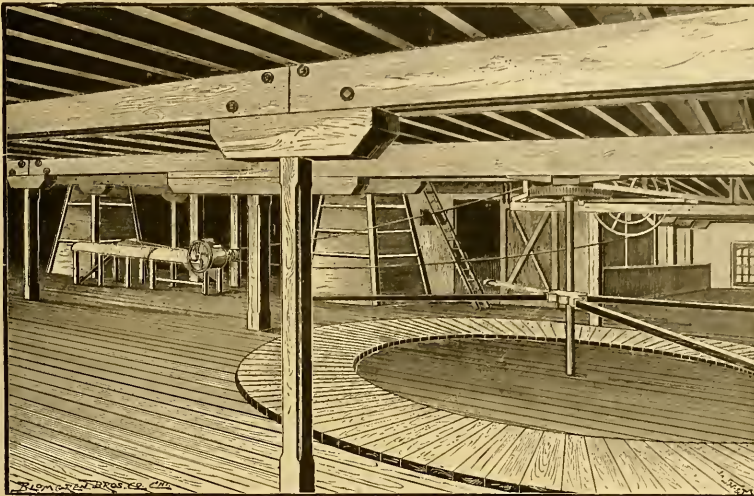

FIG. 59.—ELEVATION OF FEEDING DEPARTMENT.

being always in hand in the event that the cutter should break.

There are two mixing troughs, each 16 feet long, 4 feet high, 4 feet wide at their tops, and 3 feet at their bottoms, made of 3" stuff put together with white lead in joints and thoroughly water tight. A chute carries the feed after it is

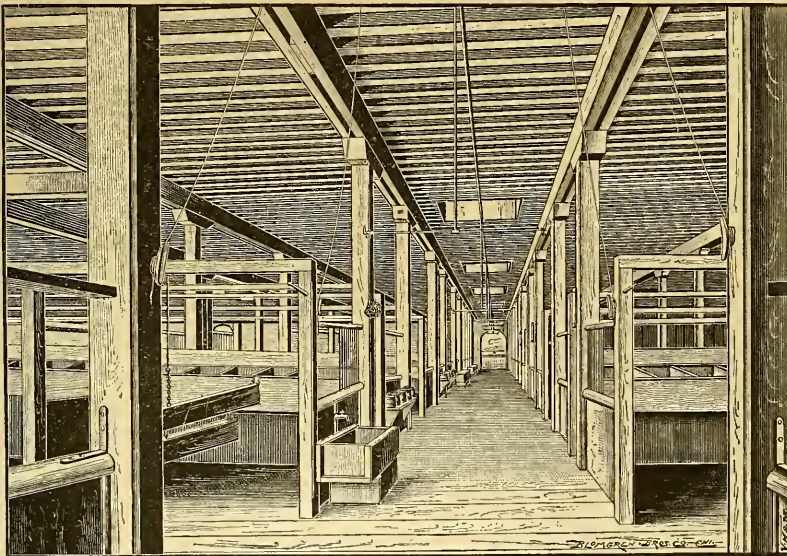

FIG. 57.—INTERIOR VIEW OF STABLE.

mixed down to the first floor, when it drops into carts and is distributed; shavings are used for bedding, as they can be cheaply and abundantly obtained during the summer, but are scarce and high, during the winter, the bedding room provided is larger, being 16x50 on the ground floor, extending clear to the roof, with an addition on second floor 16x70.



## History of Street Railways.

(Continued.)

If the thrilling eloquence of a great popular writer could have "moved" public opinion in England, Mr. Train's efforts to cover English cities and towns with street railways ought to have succeeded; or, at all events, that system of passenger conveyance should have been successfully "pushed" there by some one, right away. No less a writer than the famous Charles Dickens himself urged his admiring countrymen to "go in" for street railways when they were "in Train" over there, in 1860-1. Dickens visited America before street railways had come into use; while he visited the United States again, in 1860, he was delighted with the street cars he then found here; and when "at home," next year, he published in his "story of our lives from year to year" a glowing description of the street railway system, and persuaded—too energetically, perhaps—the people of England to "hurry up" in the march of progress, and construct street railways in London, etc.

While Dickens gave a description of our street railways, as he found them in New York, etc., in 1860, he took in all the circumstances and recorded the peculiarities of these stirring times—when the elements of our great civil war were a-brewing, and when the "blacks" of the land of Liberty had not the same full freedom to ride in a street car as at present. The picture cannot be cut down without spoiling it; so, our Dickens excerpt shall have a special chapter. Like every other true work of art, this picture (in words) is an "improvement" on the original. Several improvements have been effected since that time; but Dickens's description (with its slight inaccuracies) is a valuable sketch of the period, and an interesting chapter of street railway literature.

### V.—AMERICAN STREET RAILROADS.

BY CHARLES DICKENS (in 1861).

Street railroads may be said to be at last in Train with us in England. That is to say: After our American cousins have enjoyed the advantages of street tramways for years and years, their merits are just beginning to be slowly and timidly admitted by Englishmen.

I fear, if this tardiness to receive good things, because they are new, increase among us, if this sluggishness to welcome improvements strengthen, if this Chinese torpor to advance on better paths, because they are untried, deepen, we shall soon be justly branded by our enemies as the *Confucianists of Europe*. Let us learn, then, ere the full paralysis of Chinese conservatism and cessation of all growth set in, that no good institution is really a good institution if it be incapable of growth, modification, and development; when the fruit is ripe it begins to rot, and nothing in nature, whether flower, cloud, sea, earth, or human being, ever remains in a fixed and unimprovable condition.

American street railways, so complete, admirable, pleasant, and adaptive in themselves, are now being talked of in England as dangerous, uncertain, experimental, costly in trial, and doubtful in result. Without tiring my readers with discussions on T springs, or with diagrams of wheels and tiresome expositions of the law of forces, I will briefly describe how simply, perfectly and quietly the thing "works," to use an eminently practical man's technicality, in America.

In Boston, Philadelphia, and New York, street railroads have long been common. In the first and third city, less universally than in the second—that marble city of the Quakers—the city of Babylonian rectangles, the city meted out like a chess-board. In all these cities, the street railroad is a perfect success, which never can be done away with, till air-balloon omnibuses or steam Hansoms finally supersede horses and all other four-legged tractors.

In comparison with the order, method, and harmony of American streets, the whirlpool and storm of London, is what the confused mind of a ploughboy is to the regimental organisation of such a brain as Brougham's. The American's is the aspect of a wiser order; it is what our street physiognomy fifty years hence will be. After our perpetual charges and polings, our jerking stoppages, our wheel lockings, and

our breakings down, our delays and our impatiences, New York is a kind of heaven upon earth. American streets are what London streets should be and will be soon, if conservative stupidity, pig-headed bigotry, or unreadiness, are not allowed to cast all good and new things into the Slough of Despond. Mr. Buckle declares that scepticism is the healthiest condition the intellect can be in; to me it seems that no national mind can be healthy and growing which is not rather receptive of than antagonistic to new truths. New errors let it grind and crush, but new truths let it embrace and welcome.

Let me fancy myself, as in that lost time last year, a wanderer in New York, a trampler of the pavement, a "loafer," walking out ground plans of the sea-side city, as if, like a certain ancient Roman, I had been offered as much land as I could set my footprints on in a day.

What does it matter where I have last come from? Perhaps from Baltimore by railway, and then across from New Jersey, by steam ferry, with breezy wave and churn of froth—perhaps from the half-German town of Hoboken, where I have been playing cricket with the English residents, and talking of English ways and manners—perhaps from the sulphur springs in Virginia, or from Saratoga ball-rooms—perhaps from some village on the beautiful Hudson, thinking of Washington Irving's old Dutch legends, or talking to some poor Delaware Indian crone under a wayside tree—perhaps from the trim wooded dells that take away all painful sense of death, in Greenwood Cemetery—perhaps from watching the landings of Irish emigrants, or from observing the gyrations of trotting spider waggons in the magnificent drives of the Central Park.

I am in Broadway near the Battery, and I want to go up, miles off, into Bowery, and to slant off thence to some side avenue. The cars of the street railroad are what I wait for. I am near the dull red pile of Trinity Church, and desire to overleap space and to be in time for dinner with my friend Judge Stuyvesant, at Henderson-street, by five. I know that to take a cab or hackney-carriage in New York would evince a folly almost criminal. In the first place, Americans never use these costly conveyances, which are so expensive, partly because they are drawn by two horses, and partly because the drivers are bullies and scoundrels. Their costliness I know, because I once paid four shillings to go less than a mile—from the Astor House Hotel to the New York Hotel at the upper end of Broadway—and when I paid it, the American friend whom I was with, congratulated me on having escaped so cheaply. In fact, it is not the custom in New York to hire a hackney-coach, and only foreigners and greenhorns ever do so, and they learn to rue it.

The ordinary frequenter of the streets uses the ordinary omnibus or the street railway car. Nor has he any cause to complain of either, for the Americans are a hundred years beyond us in both sorts of conveyance—in simplicity, in accommodation, and in organisation of times of transit.

As the system of laying the rails seems not understood in England, and its difficulty is a special stumbling-block of its opponents (chiefly persons interested in the existing public conveyances) let me briefly describe the street railroad.

The rails are sunk a little below the surface of the street, so that the carriage-wheel sinks down upon them, its hollow surface fitting into the sunken rail, as in the ordinary tram-road way. As the carriages go at a sure steady safe pace, the rail is little worn, and does not often require renewal. When it does, the discomposure of the road is less than the fuss produced in our London streets by laying down a single gas-pipe. These slightly-sunk rails, which require no bristling array of dangerous points or switches, no complicated and expensive machinery of dial-plates and turn-tables, are hardly visible till you are close upon them. They rut the road, less than a gutter does, or a rain-gully. So far from being an impediment to general traffic, they aid it; and it is a common thing in New York to see a heavily laden cart, full of iron, or hogsheads, following the street railway car: the carter using the rails to ease his steaming horses. But of course only those carts which are of the right gauge, and whose wheels are not too broad for the rails, can obtain this privilege. Really to hear the Chinese of Europe talk about



this excellent modern invention, you would think that at the sight of a street railway car, all the horses within view became unmanageable, and all the riders were at once thrown off. In reality, a street railway car is far less dangerous to face than a Hansom cab, or a racing omnibus; it comes on at a quiet, even, sliding pace, and is so easy to avoid, that I never heard of even a child or an old woman who was injured by one.

But here comes a car—to return to my personality—gliding on at some nine miles an hour, slackening as I approach, to let out a batch of passengers. It moves on again before I can well reach it; but a moment's trot "at the double," and I overtake it, and while it moves, I leap on to the broad steps, catch hold of the balcony rail, and pass into the interior. It resembles a huge omnibus, it is loftier than ours and full twice as long, and is corporeally of a cheery vermilion or glowing sun-flower colour—hues not mitigated by the ardent sun and bright sea air of New York city. Outside it will generally bear, as badges of some company I suppose, varnishy portraits of Moorish beauties, or grotesque heads in cocked hats, representing the Knickerbocker whom Washington Irving made immortal in America, or the great general who was George the Third's special bug-bear, with his grand calm face, his thin cold lips, and his grave massy face. The carriage has two doors about the size of ordinary summer-house doors, both of which either shut or slide close. The rows of windows, always open in summer—for American heat would roast ice itself—pull up and down much as ours do at home. The driver, wearing no uniform or livery, but in plain paletot and wide-awake, stands (never sits) on the low small platform in front of his door, driving his two horses quietly, but with perfect ease. In summer he generally pushes back the door behind him, and chats with the nearest passengers; with that quiet, frank, manly ease, peculiar to Americans in such ranks of life. More generally, if the passengers are inclined to be silent or want the door shut, he slides the door, and talks to somebody who stands beside him, or to the conductor, who, having collected his cents, has saved time for conversation. Talk to the driver. He will stand no nonsense of English pride, but you will find him sensible and well informed, full of quiet self-respect and the confidence that arises from it.

The conductor has his own coteries, his gossips and familiars, on the platform at the other end of the car. It is guarded by a low partition four feet high, against which passengers preferring the open air can lean, or on which they can sit: though sitting is rather unsafe, unless you hold tight, as a sudden jolt or a sudden increase of speed might make you fall backward. The platform is wide enough to hold another passenger beside yourself, if he choose to keep himself together, and lean against the opposite side of the carriage on either side of the door. Without crowding, there might, with the conductor, be room (on the two steps and all) for about six persons on the outside of the car and platforms; but in the evening, when merchants are coming home to dinner on the river-side railways, I have seen a dozen or more clinging on to different parts of the small enclosure; but this is exceptional. The conductor is a neatly dressed man, in no distinctive dress, differing in no way from the passengers generally; quite as well mannered; and manifesting no servile deference; never impertinent, and with no mean tricks. When you have been seated on your red velvet cushion for perhaps ten minutes, you will see him walk up and down the centre of the carriages, collecting his six or ten cent fares. If he wants to tell the driver to stop, he pulls a leather strap that runs along the roof of the carriage, and strikes his alarm, and warns the driver to pull in his horses. When the car is stopped, another pull of this roof-strap tells the driver to go on. The use of this strap is not confined to the conductor; any passenger is entitled to pull it if he wants to stop; or if anything disagreeable has happened in the carriage, such as a quarrel, or the admittance of a drunken man.

There is no uneasy stir and anxiety to make sure of being put down in the right place, as in England; no necessity to probe and puncture the conductor, as in London. It is all methodical, simple, complete. If you are young and alert,

you do not stay to pull the string, but quietly drop from the back step (which is not a foot from the ground) without haste and without fear.

The inside of the carriage holds some forty or more people without crowding. It is a little room in width, and there is no fear of your toes being constantly trodden upon as in English omnibuses; there is no annoyance from other people's dirty boots and dripping umbrellas. The conductor, when he walks down the centre, brushes nobody's knees. There is, indeed, no limit to the numbers—seventy or eighty or one hundred—these cars will hold at the same time.

The extra number are not, however, jammed or driven into rows of seats already filled, but they stand comfortably in the centre of the carriage, holding by leather loops attached at intervals from the roof for this purpose. For short distances, many people prefer standing to sitting.

There are no seats on the roofs of the street railway cars; it is too hot in summer and too cold in winter for such an altitude to be enjoyable; and the risk and trouble of scrambling about an omnibus roof is never very enviable, even if the mode of sitting were pleasant. I should mention, also, that the windows of these cars have always effective blinds. The fare, too, is fixed, and very cheap.

These cars have also, like those of the Paris boulevards, another great advantage. Every Englishman must remember the unpleasant moment when he jumps into an omnibus; before he can get a seat, on goes the vehicle, sending him tumbling headlong over a suffering path of toes and corns, and dank dirty straw, and at last into a seat, between two angry, hurt, and reluctant people—perhaps a ruffled old maid and a gouty millionaire, fresh from losses on the Stock Exchange. The French, mathematical and organising by nature, orderly Quakers in comparison to us business slovens, have long since got over this, as all people who have been to Paris will remember with pleasure and gratitude. They have a long brass rail running on either side of the roof, the full length of the carriage. The Americans have overcome the same difficulty, equally simply, by means of the leather loops depending from the roof, before mentioned. But, indeed, the soft easy gliding motions of the street railway car, neither jerking, nor leaping, nor joltingly abrupt, does not so much need this precaution, though it is still a comfort.

The American street cars run from well-known terminal depôts, at certain well-known intervals of time, and never at any other. They do not rush off brutally, ten together, like a pack of hungry curs, to fight and wrangle for the same twenty passengers, but are orderly as the planets. They run at graduated hours, and with proper intervals between each other. Each horse, each carriage, each driver, each conductor, performs so many journeys in the day. The horses are never jaded, and the carriage, full or empty, never lingers at crossings, side streets, or public houses. You never have to wait twenty minutes for a conveyance. I have already said that these street railroads require no turn-tables or other mechanical appliance. The reason of this is, the ingenious construction of the carriages, which are provided on either hand with iron holders for the traces, and with boxes to receive the pole; thus, when the driver gets, say to Haarlem, and wants, after resting his prescribed quarter of an hour, to return to the city, the grooms of the terminus stables merely unfasten the horses (Americans, on account of the heat, use very little harness) from the front, and attach the animals in two minutes to what was just now the rear.

There is no bawling of scurrilous conductors in American streets. Everyone can read the names of places in large legible letters on the street cars; if a stranger wants to inquire his way, it is worth ten cents to leap on the step, ride for a few minutes, and learn the road from the conductor: who, if he sees him to be an Englishman (and they always find an Englishman out), will be delighted to have a few minutes' talk with him.

The American omnibuses are not much better than our own. They are small and the fare is dear. They are generally, in New York, of a white colour, which gives them a singular appearance of cleanliness and brightness. They

rule in Broadway rather insolently, because the street railroad has not yet reached that Regent-street of the American commercial capital. Vested interest has been too strong; but a day will come, and probably soon (for the Americans are not slow-handed when they see a good thing within reach), and the omnibuses will pass away out of sight like a flight of white butterflies.

In two respects, only, do the American omnibuses differ from ours. In the first place they have no roof-bench seats; secondly, you do not pay the conductor, as with us—for there is no conductor—but you touch a bell to inform the driver, and then slip your silver cents into a little locked red glass money-box just below the driver's seat, and where he can see what you put in—though he seems generally, I observed, to trust to a passenger's honour. You ring the same bell, if you want to stop. On the outside, these omnibuses are generally adorned with paintings of Indian chiefs, portraits of Knickerbocker and Washington, allegorical figures of Liberty waving "the star-spangled banner" over a very blue and narrow Atlantic. I believe that sometimes when Cuban planters, or old irascible, controversial, and rather pompous Louisiana gentlemen owning "cotton hands" are present, there is a stir made if a negro gets into a street car; but this, within my knowledge, seldom happens in the North, though sometimes rowdies, black sheep themselves, excited by liquor, have been known to try and turn out black passengers. The very last time I was in a New York street car, a perfect flock of blacks got in. We were coming from the Central Park to Broadway, a long distance, passed several old Dutch-named streets, and I had plenty of time to watch the passengers' behaviour.

Opposite me sat a very poor old grey negro plasterer, with his bag of tools at his feet; there were spots of white-wash on his grizzled hair and pathetically grotesque features. A poorer and more jaded son of toil one could not meet with; his thin blue linen clothes were patched and spotted and threadbare; his eyes were worn and pale; it was evident that the sands of the poor old negro plasterer's life were all but run. Death would soon claw him in his clutch. He would soon be cast into the great black dust-hole where no colour can be seen, for the sun is not there, neither the dawn, and there king and slave sleep side by side without grumbling at each other. No one pushed the poor old negro, no one moved from windward of him, no one struck him, no one turned up his nose at him. The conductor took his fare as he did that of the other passengers. He even chatted to the poor old soul about to be gathered to his unknown black fathers. There was nothing either disturbed or intrusive about the old plasterer.

There were seated, also, not far from "this old image of God cut in ebony," three young Creole girls, smartly dressed, who, from the band-boxes resting on their knees, I set down as milliners. They, too, were quite at their ease, slightly contemptuous of the old plasterer—not because of his Ethiopian skin, but because of his poverty and grime, as I presume. Still there is no doubt that had a hard ungracious Southern man entered the car, and complained of colored people's impudence, the conductor would at once have sent the poor black sheep of the human race to the right about, and turned them on the outside balcony.

A propos of the separation of the black and white pieces on the United States chessboard, I will here mention what I saw one day in the South. I was there in a time of blood-heat excitement. There were rumors of negroes burning villages and poisoning the wells in Texas. A Western preacher, suspected of being an itinerant Abolitionist agent, had just been hung by Judge Lynch's stern myrmidons somewhere in Missouri. I had pointed out to me, at every railway station in Kentucky, spies watching to see if any Northern travelers or English passengers whispered or drew aside the negro railway porters. I could not stir without finding a sallow eye augering into me. I was afraid almost to speak kindly to the negro slave waiters at the hotels in South Carolina. The local papers were full of news of Palmetto regiments with red-starred banners enlisting in Charleston; of Virginia men buying guns and powder; of Alabama purchasing cannon; of Louisiana

burning to take arms. I looked particularly, in all the Southern railroads and stage cars, to see if the blacks were kept carefully separated from the whites. I did not find the distinction very severely maintained, though there was generally a special car in which, partly by prescription, and partly from custom, the blacks seemed to congregate.

On an Alabama river-boat, I remember two slaves, sturdy young men, just bought in a New Orleans slave store, and going down with their purchaser, a small holder, to Montgomery. Scipio and Juba were dressed exactly alike, in jacket and trousers of coarse blue cloth; such suits as slave merchants are accustomed to throw into the bargain, tending as they do to set off their planter's purchase. There, day after day, for I spent many days aboard that terribly frail and dangerous steamer, the "Hickory Nut," sat, on a bale of cotton just outside the dining saloon door, those twin negroes, Juba and Scipio, like two black turtle-doves; always in the same place from morning till night; always whispering in the same quiet, passionless, imperturbable way, their conjectures, I suppose, about their new master and his plantation, or quiet sarcasms on the last master, now probably employed in liberally dispensing tobacco-juice over the quays of New Orleans. We "wooded," we glided on, we stuck on sand-banks, we got off sand-banks, still the twin ravens sat whispering on the cotton bales. It was a great relief to me when suddenly at "Nash's landing" the master got out, followed abjectly and gravely by the two blacks; Scipio honoured by his trunk; Juba by his carpet-bag and umbrella. They passed up the red-sand cutting in the steep river bank, and disappeared down a distant street. But I have every reason to suppose that Mr. Ezra Harbottle is still wandering over the world, followed at a respectful distance by Scipio and Juba. For, a week after they left the boat, I met the three in Montgomery, walking processionally in exactly the same manner—only, this time Scipio carried a green parrot in a brass cage, and Juba a hat-box and a rifle.

To return to my subject of street railroads. I saw them in full operation, not only in New York, but also in Boston and Philadelphia. The latter city is divided by streets intersecting each other at right angles. Here, if anywhere, confusions and stoppages might be expected to arise from street railroads, but no such confusion occurs. The street car is stopped more easily than an ordinary vehicle. If another car be seen coming, the conductor pulls his bell, and the other car waits at the crossing until the other has passed. It is true it can not move off the rails to avoid obstacles, but it can stop for them. At Boston they work equally well, running deep into the fashionable streets, and running out again into the far distant suburbs, past Longfellow's pleasant home, and up to the beautiful cemetery on the steep banks of the Schuylkill. There must come a time when street railroads will be found all over the European world.

*To be Continued.*

THE LYVER SYSTEM of tramways is to be substituted in the city of Liverpool for the method hitherto in vogue. "The powers granted by Parliament to the city of Liverpool, gave to that corporation authority to purchase the rails and street fixtures belonging to the car companies, at a fair valuation, and to proceed, under the city engineer and commissioners, to lay tracks, pave streets, and do all things necessary for a gradual equipment of the entire city with the new method. The money therefor was borrowed for this special purpose, the interest of which, together with the cost of maintenance of the streets and tramways and the salaries of the commissioners in charge, being paid by the different car companies using the same, a small monthly charge per car being made. This system, while it preserves to the city the complete control of its streets, insures their being properly maintained, and prevents the complication that now arises from suits for damages, when the city is supposed to pave on the outside and the car companies on the inside of tracks. And this system requires no digging up of the streets to lay new rails, while the filling in between paving blocks with three-eighths of an inch of asphalt, effectively prevents noise, and gives a much better foothold."



## Mechanical Traction on Street Railroads.

NOTES ON EXPERIMENTS IN EUROPE, 1870 TO 1880.

BY E. E. RUSSELL TRATMAN, JR. AM. SOC. C. E.

GREAT BRITAIN—Continued.

*Wootton.* The Wootton Tramway, from Quainton Road to Brill, was built about 1871 by the Duke of Buckingham on his own property; the line, however, crossing several public roads on the level. The line—standard gauge—was about 8 miles in length, and had easy grades, with the exception of one of 1 in 50; it was built with light track and works, at a cost of about \$7,000 per mile, exclusive of land, it being intended to operate it by horse traction; but after one year's working in this manner, small locomotives, similar to those used by contractors, were adopted and proved satisfactory. There were small stations on the line, or more properly waiting rooms (as there were no officials), and the line was a great benefit to the agricultural district through which it ran. The engines were capable of a speed of 10 miles per hour, and the rolling stock consisted of 10 freight cars and two passenger cars of the ordinary street railroad type, one of these being attached to each train. The bulk of the freight traffic over the line was hauled in freight cars of the Great Western Railway, and the London & North-western Railway. On approaching road crossings the fireman got down and opened the gates, which were closed after the passage of the train by the conductor, who occupied the rear car. Tickets were issued by the conductor.

### EUROPEAN CONTINENT.

*Cassel (Germany).* The line from the town to the park at Wilhelmshöhe was opened July 9, 1877, and was worked by steam from its commencement; it was laid along a straight road with a width of from 33 to 39 feet, the road being hilly and too steep for horse traction. It was a single line—standard gauge—with turnouts, laid in the middle of the road with room for vehicles to pass on both sides; its total length was 3.5 miles of which about .62 mile was in the town, the line running through the market place; the grades were as follows, outside the town: ascending 1 in 18, 1 in 16.5, 1 in 22 (on curve), 1 in 25, 1 in 35, then a down grade of 1 in 25, followed by an ascending grade of 1 in 45, and in the park was an S curve with grades of 1 in 25 and 1 in 35. In 1878 there were 8 engines (separate), six by Merryweather and two by a German firm, the former carrying condensers on top; they weighed from 11,200 pounds to 13,440 pounds, and were about 18 H. P. No emission of smoke or steam was allowed in the town (steam was allowed to escape when beyond the town), and the engines were required to be noiseless; the speeds permitted were 7.5 miles per hour in the town and 8.66 miles per hour beyond, but authority was applied for to run at 9.33 miles per hour—the speed set by law for secondary railroads; they had brakes on each wheel and could be stopped in their own length—13 to 16 feet; they could stop and start on a grade of 1 in 18. Only two cars were allowed, one carrying 38 and the other 32 passengers. Trains ran every 20 minutes, there not being sidings enough to allow them to run more frequently. The distance was too short for freight traffic. An American snow plow was used to clean the rails in winter. Although the first cost was very heavy the line was fairly successful financially in 1879. The inspecting officer of the Board of Trade (England) visited the line in 1879 and reported the track badly laid and the engines noisy.

*Copenhagen (Denmark).* In 1875 a steam car was permitted—after being examined by a government commission—to be run on the line outside of, but not to enter, the town; owing to numerous defects, however, it was soon withdrawn. In the fall of 1876 an improved car was introduced and worked satisfactorily. The following were the conditions required by the commission: absence of visible steam or smoke and of noise from machinery; power to ascend grades of 5 per cent. with a load of 22,400 pounds; a pilot frame in front, and bells to ring by the motion of the engine. The speed was limited to 9.5 miles per hour by the

police regulations. According to the Copenhagen Tramway Company's report for 1874, the cost for horse power was 12.2 cents per mile for a car carrying 40 passengers, or .305 cent per passenger mile.

*Haarlem (The Netherlands).* A Merryweather engine was experimented with for three weeks in 1879. The line was single track—standard gauge—and one mile long, but was to be extended to the coast. It ran through the principal streets, which averaged 25 feet in width, but in one place the street was only 14.33 feet wide.

*Hamburg (Germany).* Street railroads were introduced in 1868 and steam power was first used in 1878, from the center of the town to the suburb of Wandsbeck, a distance of about 6 miles. There was a grade of 1 in 30 or 1 in 35 on which a third horse was employed for the horse cars. The engine was built by a Swiss firm and ran alternately between the horse cars. The road on which the line was laid was said to be in very bad repair.

*Liege (Belgium).* A Varsen engine was put on this line in September, 1877, and continued running till the following March, when it was withdrawn in consequence of an accident which it is said was not incidental to steam power. The streets were very narrow, one of them being only 18 feet between curbs and 26 feet between houses; in these narrow streets the track was laid near the sidewalk, leaving only 12 or 18 inches between rail and curb. The line was fairly level, the maximum grade being 1 in 20 in the suburbs.

*Nantes (France).* The line was opened February 13, 1879, and was worked by compressed air from the beginning. It was about 2.5 miles in length, in the busy part of the city, and double track for the greater part of its length, being single only in some narrow 25 feet streets; there were practically no grades except in one place over a bridge. Each of the sixteen "combined" cars carried under the floor ten cylinders containing air at a pressure of 30 atmospheres (450 pounds) per square inch; only seven of these were exhausted on the round trip of 5 miles, the others being kept as a reserve. The air on its way from the reservoir to the engine cylinder passed through a hot water boiler by which it was heated from a state of condensation to rarefaction. The working pressure in the engine cylinders was from 90 pounds to 105 pounds per square inch. Large and expensive plant was required for charging the cars, the time for this operation was 30 minutes. The trip of 2.5 miles occupied about 25 minutes and the line was worked night and day.

(To be continued.)

COLLECTORS FOR ELECTRIC STREET RAILWAYS.—M. Holroyd Smith, Halifax, Yorks, England, makes six claims in his patent for special arrangements. His collector consists of two clearing ploughs and one centre piece, and the desired flexibility is obtained through the employment of hinges. Various forms of contact makers are applicable, to run as circumstances may require, and the collectors are mechanically attached to the car by means of ropes. The gatherers are connected to the terminal wires by a strap.

INSPECTORS for elevated railways are proposed by the New York State legislature. In reference thereto, vice-president Galloway, of the Manhattan Railway Company, declares: "It is plain to us that the object of the bill is to create offices for the benefit of some one or other at the expense of this company. The legislation is utterly unnecessary. We have the structure thoroughly inspected every day, and, if anyone thinks he can do it better, we do not happen to know him. It is of the utmost importance to this company that we should guard against accidents in every possible way, and we fully appreciate the care and the danger. A board of state inspectors could not do the work more thoroughly nor increase our sense of responsibility." The bill in question is to authorize the Governor to appoint an inspector-in-chief of the elevated railroads of the State. He is to receive \$4,000 salary, is to serve for three years, and is to have the right to appoint a deputy for every six miles of elevated railroad track. The deputies are to receive \$2,500 salary.

## American Cable Railway Construction.

BY AUGUSTINE W. WRIGHT.

### PART I.

The rapid increase in the construction of cable railways, and the consequent demand for information concerning the method pursued by the various companies in their building, has induced me to prepare the following pages describing as fully as may be by pen and illustration the work accomplished by the skillful engineers who have superintended the said construction.

Ere the locomotive engine had made its advent, inclined railways, worked by stationary engines, operating drums around which ropes were wound, had been introduced. Wood's Treatise on Railways states: "In the year 1788, Mr. Reynolds completed, at the Ketley Iron Works, an inclined plane, formed of a double iron railroad, by which a loaded boat, in passing down a frame constructed for the purpose, drew up the boats which were empty. Since that time, many inclined planes have been made upon railroads for the purpose of drawing up the empty carriages by the gravitating power of the loaded carriages down the plane. \* \* \* \*

In 1808, Mr. S. Cooke erected an engine upon Birtley Fell, in the county of Durham, to draw the loaded carriages up the Urpette's Colliery, across the Durham and Newcastle turnpike road, up a steep ascent, and since that time they have been much used upon the railroads in the neighborhood of Newcastle."

The Liverpool & Manchester Railway appointed a committee, consisting of three of the most eminent engineers in England, to report upon the best motive power for their railroad, in 1829. As is well known, Messrs. Rastwick and Walker reported in favor of stationary engines, working ropes; Robert Stephenson, in favor of locomotive engines.

Many years elapsed before mechanical ingenuity had perfected the details and enabled wire rope to be manufactured. The hemp ropes used previously were not *endless*, but a train drawn in one direction carried a tale rope with it. The rope was drawn backwards and forwards. To American inventive genius is due the adoption of an endless wire rope—the basis of all systems of the so-called "cable" railways of to-day.

In 1858, Mr. John H. Gould, of Philadelphia, and Mr. James Gardiner, of the same place, patented the combination of an underground tube containing a moving cable and

wheels for its support, the tube communicating, by means of a slot, with the surface.

The *Mining and Scientific Press*, of San Francisco, September 3d, 1881, contained an interesting and valuable article upon cable railways, from which I quote, as follows:—

"In 1859, Messrs. Foster & Brown, United States, proposed to employ an endless traveling rope, supported over head by arms attached to posts. A catch or grab is attached to the car of the street railroad; a spiral spring intervenes between the car and the catch. When it is desired to start the car, the catch takes hold of the overhead rope. This is very similar to Beauregard's patent of 1869. (Fig. 1.)"

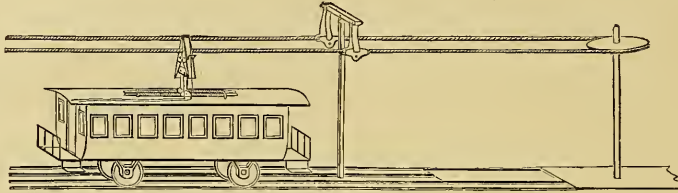

FIG. 1. FOSTER & BROWN'S STREET RAILWAY, 1859.

thorn, of Great Britain, in 1863, proposed to actuate, by means of a traveling wire rope, a number of wheels placed between the tracks and the carriages. The carriages were to be provided with draw bars, which were lowered so as to come in contact with the revolving wheels, and thus move the carriages.

In 1864, Mr. A. C. Beach (now of the *Scientific American*) proposed to move street cars by a chain with peculiar links running in a grooved rail and connected to car by a simple arm. The chain had friction rollers attached. He also combined the brake with the connecting device to insure co-operative action. (Figs. 2 and 3.)

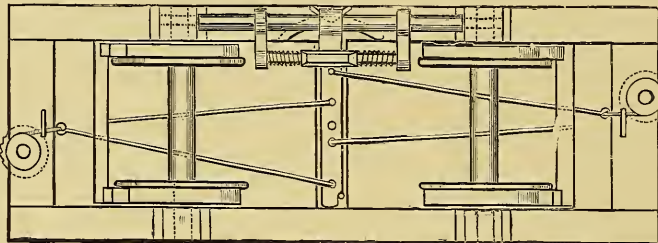

FIG. 3. A. C. BEACH'S STREET RAILWAY, 1865.

rails in which it moved; also, in the forked arms for catching the chain. He took out six patents on this system.

"In 1866-67, Charles T. Harvey, United States, proposed using ropes with bulbs or ferrules on them to catch the arm projecting from the car. He drags the rope through an open tube and places hardened rings around them to prevent wear. The rope runs on the surface of the road under the car. He also proved an elevated railroad with the track supported on the tops of columns—the cars to be drawn by a moving rope with bulbs or ferrules on them, a long spiral spring intervening, as in Foster & Brown's arrangement, 1859. (Figs. 4 and 5.)"

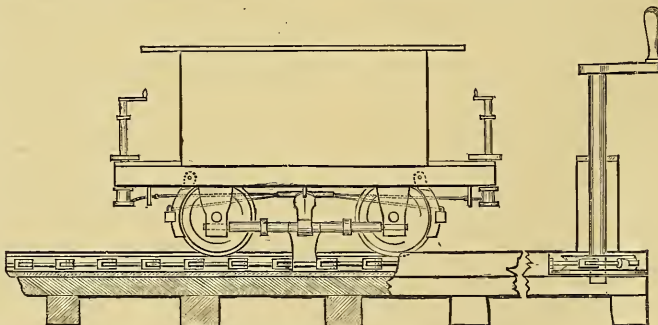

FIG. 2. A. C. BEACH'S STREET RAILWAY, 1864.

A. Fountain proposed a cigar shaped balloon, with machinery and wheels with deep grooves, running on wire ropes stretched in support, the weight of the cars being counter-balanced by the buoyancy of the balloon.

"In 1869, G. F. Beauregard, United States, proposed some modification in the invention of Foster & Brown's elevated road of 1859, relating to the clamp or grab to



catch the overhead traveling rope; Sutton and Brownell made some improvements in the mode of connecting a rope with knots or protuberances with the car, using a sprocket wheel for this purpose. (Figs. 6 and 7.)

"The same year W. M. Smith, United States, and others,

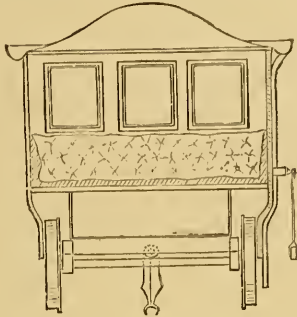

FIG. 5. C. T. HARVEY'S STREET RAILWAY, 1866.

took out patents in this country and England for improvements in elevated roads.

"In 1870, Walter Hyde invented an elevated railway, using two wire ropes and a bucket or car suspended by sheaves on the upper one, and by means of a drum in the bucket worked by the occupants and around which the lower rope was placed, the car was caused to be propelled along the upper rope. (Fig. 8.)

"In 1872, Mr. Abel Thompson, United States, proposed to run a locomotive in a tunnel underground and to connect it with a car running on a track in the street by means of an arm running up through an opening in the crown of the tunnel."

In 1870, Mr. Andrew S. Hallidie, of San Francisco, U. S., was granted his first patent for a grip pulley, and after that time he took out a number of patents on cable railroads. He matured his system in 1871, but met with no encouragement and was confronted with considerable obstacles. In 1872, he interested some friends in the project. It was decided to build an experimental line in Clay street, San Francisco. The ground was broken in June, 1873, and the work of construction began.

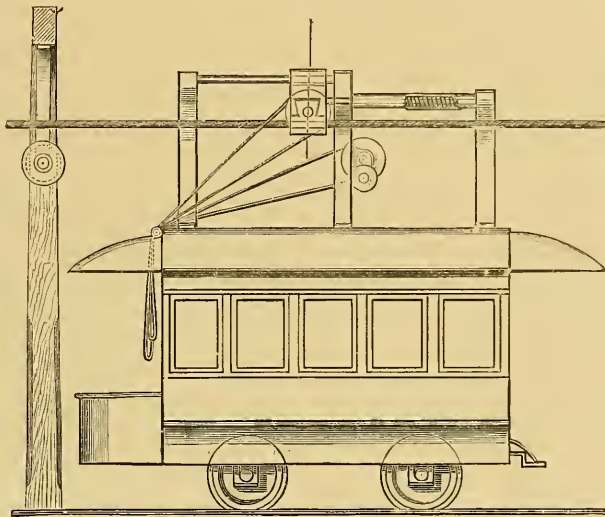

FIG. 6. G. F. BEAUREGARD'S STREET RAILWAY, 1869.



FIG. 4. C. T. HARVEY'S STREET RAILWAY, 1866.

Mr. Hallidie gave the construction his personal attention, assisted by Mr. Wm. Eppleshmier, who had previously been in his employ as draughtsman.

The terms of the franchise required the cars to be run

on Aug. 1st, 1873, and the morning of that day, at 4 a. m., the engine was started. It was a gray morning, and fogs were hanging around on the hills, the ground being moist and slippery. The rope, 7,000 feet long, moved through its long tube under the surface of the street quietly and satisfactorily. The dummy containing the gripper was brought to the brow of the hill, looking over the bay, and the grip lowered into the tube containing the moving rope. Long ropes were attached to the frame of the dummy, and it was lowered a few feet over the brow of the hill, to ascertain if it could be stopped on the steep incline in the event of the grip's leaving its hold on the cable. The brakes proved inadequate, and the prospects of plunging down Clay Hill were promising. The hill looked very steep, that morning, but after consultation it was determined to proceed. The man detailed to manage the dummy turned pale at the prospect and Mr. H. took charge of it, and fastening the grip upon the rope in the tube, went over the brow of the hill. Together with Messrs. Britton, Davis, and six of the employees, he reached the bottom of the hill in safety, having tried the grip in several ways—stopping at the crossings, starting up, pushing the dummy in the opposite direction to the moving cable, dropping the cable, picking it up again, etc.

At the bottom of the hill the dummy was reversed and the grip again made fast to the cable, and the car proceeded up the hill. A public trial took place in the afternoon in the presence of an immense crowd. The trip down was made all right and without interruption; but the crowd was so enormous that the workmen could not do their duty, nor could the police keep the crowd back. Everybody seemed pleased at the success and were over-anxious to help; consequently, in turning the dummy, it was turned with such a will that the grip was disarranged, and the workmen had to be sent into the pit, under the surface of the street, to replace some of the disturbed parts. This necessarily consumed some twenty minutes, and during this time the crowd increased in volume and excitement, making all kinds of remarks, but generally deploring what they believed to be the failure of the experiment, as the car and dummy did not start as soon as they expected.

It was the intention to take the car up empty, and to permit three or four of the public to stand in the dummy, but the desire of the people to ride was so great that the doors were forced open and the car was crowded far beyond its capacity. In like manner people clung on the dummy, so that about sixty persons managed to get a free ride at their own risk, and when she started and moved about twenty feet, cheer after cheer rang through the air, and the surging crowd ran up Clay street, keeping pace as well as it could with the progress of the car.

About half-way up the hill there is a sudden change of grade to 1 in 6. Here the car and dummy wavered, and finally stopped on the steep hill. The people tumbled out and determined that they should not stop there, and gave the car a push and set it moving up the hill. Meanwhile, Mr. Hallidie, suspecting what the trouble was, jumped into a wagon and drove to the engine house.

(To be continued.)

# The Street Railway Gazette.

Subscription, \$2.00 per year; per copy, 20c.

PUBLISHERS:

THE WRIGHT-MONROE COMPANY.

Augustine W. Wright,	President.
E. V. Cavell,	Secretary.
S. L. K. Monroe,	Treasurer.

### GENERAL OFFICES:

CHICAGO, NEW YORK, BOSTON.

C-ICAGO:

9 LAKESIDE BUILDING.

P. G. Monroe,	General Manager.
G. G. Minor,	} Editors.
William Hughes,	

NEW YORK:

181 BROADWAY.

Henry C. Lockwood, Resident Editor and Manager.

BOSTON:

198 WASHINGTON STREET.

T. P. Pemberton, Resident Editor and Manager.

### EUROPEAN OFFICE:

LONDON: W. S. Graft Baker, Jr., Resident Manager.

### BRANCH OFFICES:

ATLANTA, Ga.: Chamber of Commerce Bldg., Wm. Minnigerode, Mgr.  
SAN FRANCISCO, Cal; 1222 Bush St., G. W. Fairchild, Manager.

### CANADIAN AGENCY:

TORONTO: 53 Magill Street,—Thomas Henry, Manager.

## Our European Representative.

THE STREET RAILWAY GAZETTE has been accorded a most flattering reception in Europe, and the Wright-Monroe Company have been cordially invited to issue a London edition thereof. The directors, engineers, and managers of British tramways (many of whom have been recently entered on our subscription list) find the GAZETTE edifying and encouraging in street railway enterprise. The presidents and officials of American street railways, on the other hand, are gratified with the intelligence furnished by the GAZETTE concerning the progress of the best modern means of inter-mural transportation on the other side of the Atlantic. And Mons. F. Nonnenberg seeks the opportunity, through the medium of our columns, to place before the street railway gentlemen of America and England the aims and objects of the Permanent International Tramways Union, of which he is the Secretary.

We have much pleasure in announcing that Mr. W. S. Graft Baker, Jr., late of Baltimore, Md., has been appointed our Resident Manager in England, and will be the GAZETTE representative for Europe. He will open his offices in London forthwith, the location of which we may be able to announce in our next issue. Mr. Baker has been closely connected with British tramway officials for several years past, to many of whom he is well known. He will represent THE STREET RAILWAY GAZETTE at the ensuing Paris Railway Jubilee also, as well as at the Vienna Tramways Convention in the Fall.

With this direct connection we hope to keep street railway officials, stockholders, and all interested therein throughout the civilized world, posted up with reliable information, and brought into closer acquaintance, and thus be of great moral support to one another in withstanding the pressure of popular prejudice against the extension of "one of the greatest and most economical social reformations of the age." New inventions, manufactures and improvements of real merit, from whatever quarter they may come, shall be promptly and faithfully set forth in our columns; and through the medium of the GAZETTE, street railway companies everywhere shall have the opportunity to procure

whatever is best—whether for horse, steam, gas, cable, or electric railways; on the surface, underground, or elevated. Our illustrated descriptions of the various cable systems, and of the electric railway experiments, etc., have been highly appreciated. We hope to be able soon to publish additional important information concerning the application of electricity to operate street railways; and the work of Mr. Augustine W. Wright, C. E., on "American Cable Railway Construction"—which comprises detailed illustrated information concerning every practicable variety of cable railways—is written expressly for THE STREET RAILWAY GAZETTE. The first chapter appears in this issue.

THE Myer street railway bill (otherwise known as the Adams street railway bill) passed the Lower House at Springfield, Ill., March 17, with the emergency clause. As stated in the MARCH GAZETTE, it forbids the granting of street railway franchises except by consent of a majority of the property-holders on each mile. The yeas were 106, and the nays only 6. In the Senate, March 22nd, Senator Eckhart, by unanimous consent, called up the bill and advanced it to second reading; March 29 it was read third time, and passed the Senate. It applies to steam, horse, dummy, and other railway companies; and thus the majority of the owners of property abutting on any mile of a projected street railway are enabled to play the dog-in-the-manger with a vengeance, and stop the line against any number who may be anxious to have it.

"Who owns the streets?" is a question about which opinions widely differ. Owners of property abutting on a street think the street belongs to them, as much as a river belongs to the owners of the land through which it meanders, or more so. This is a mistake. "Certain members of the city council," says a Chicago evening paper, "are enthusiastically of the opinion that the streets are their personal property." Such a notion is altogether too personal. Then certain drivers of carts and wagons and other vehicles imagine that the public streets are entirely for their accommodation; and not only the streets, but they often make use of the street railway tracks as if they were their own "personal property." These latter people have been taught their mistake by judicial fines, from time to time. And the only false notion that requires serious consideration is the property-owners' "monopoly." The truth is that the streets of a city belong to the general community. The tradesman who dwells on the New York Bowery, or Chambers Street, is almost as much the owner of Fifth Avenue as the wealthy residents of that millionaire thoroughfare. We can not well dispense with the "almost," and we consider that the literary luminary of Chicago went to unreasonable extremes by declaring that "The street in front of Potter Palmer's or Mr. Leiter's, or Mr. Any-other-man's property is no more his, to dispose of or control, than it is the man's who owns a cottage on the North Side and who passes to his work on the South Side over that street. The streets are the common property of the general community." With the last sentence of the quotation we agree; but it should be qualified by the fact that various members of a municipal community, like those of an orderly family, vary in capacity, disposition, and requirements; and the rule of "give and take" should be applied in the one as well as the other. And, as President Yerkes holds, although a legal right may be obtained to construct a street railway, or an "L" road, or underground line on, above, or through any street, it is not wise to do so against the determined will of the whole of the property-owners and residents on such street. But, on the other hand, it would be monstrously mean and utterly wrong for the "owners" of a public street (if such a phrase may be used) to ignore the convenience of distant neighbors who may want to use the street to carry them to and fro; and the rule of the majority, in its application to city streets, should include the majority of the whole community, or, at least, the majority of all the parties interested, and not a select "majority."



JUDGE Van Brunt has decided, in New York, that the city owns the streets. The New York Arcade Railway Company is thus at liberty to construct its four track railway underneath Broadway; and the complaints of Hiltun, Potter, Astor, and Mann are swallowed up by the rights of the majority—not the majority of the owners of abutting properties, it may be, but the greatest number of all parties interested—far and near, that may have business in B'dway.

WE are under obligations to the Hon. E. B. Pond, Mayor of San Francisco, California, for valuable information and documents anent intermural transportation in the golden city; and we thoroughly appreciate his honor's explanation of the difficulty which has to be overcome in obtaining strictly accurate information concerning street railways in American cities.

THE French Railway Jubilee is to be opened at Paris May 1st. Exhibition Palace, in the Bois de Vincennes, will cover from six to ten acres of ground. Five miles of track is being laid for the use of exhibiting the several systems of steam, electric and horse railways. Besides this a belt line about three miles long, will provide for the passage of international trains, connecting the various depots with the Exhibition Palace. The Exhibition street cars will run from the Russian station, through the centre of the park, past the English Fêtes grounds, to the Marc Seguin statue (in front of the Exposition); and another line, beginning with a loop, will start from the Italian station, joining the other tracks near the Seguin statue, and then both continue on a single line beyond the French station. There is no opportunity to exhibit the cable system.

KANSAS CITY—the Chicago of Missouri—is heartily followed and co-operated with by its neighbor, across the river, in promoting street railways. And by the united efforts of Wyandotte and Kansas City, whereby the two cities are becoming very closely united, the most gigantic networks of railways ever devised for local traffic are being accomplished. The city council of Kansas City have passed an ordinance granting a franchise to the Brighton Hill and Chelsea Park Railway Company to construct a line of road from a point on Fifth street, near the intersection of the elevated road and Jersey street, westward through Sunnyside and Brighton Hill, up the Jersey Creek Valley to the picturesque and beautiful Western highlands, formerly the Hurla Homestead, thence along the entire south boundary of Western highlands to Chelsea Park, where it will make close connection with the Riverview cable line, forming a double track belt line through the most beautiful portions of the consolidated city and bringing it into close communication with Kansas City. Franchises are being asked for in every direction, and as fast as secured the work of construction is begun, and within a couple or three months trains will be running on the Brighton Hill and Chelsea Park line, and shortly after that on the Riverview line. The directors of the Riverview Railway Company (whose capital stock is \$200,000) are D. M. Edgerton, Chester Bullock and Daniel D. Hoag, of Wyandotte; Robert Gillingham, of Kansas City, and L. G. McNair, of St. Louis. The directors, it may be observed on reference to our "pointer" under Wyandotte, Kansas, are in the main the same for these two companies. And these same men own a controlling interest in the Interstate Elevated R. Co. In fact, these two new enterprises across the Kaw river are "simply extensions" of the elevated line which now connects Kansas City with Wyandotte. The original plan for the line through Riverview was a cable, but the property owners, who subscribed upward of \$3,000 toward the construction of the road, are now petitioning the company to construct, instead of the cable line, a road to correspond in every respect with the surface portion of the L road and the Brighton Hill and Chelsea Park road. It is maintained that "the many advantages of the noiseless motor over the cable are apparent to the parties interested," and that in all probability the company will yield to the wishes of the liberal donors to the enterprise and construct a motor line instead of a cable.

CABLE TRACTION is virtually "steam power," as has been decided by the New York State Court of Appeals. And a bill is now pending in the Legislature to amend the surface railroad Act of 1884, providing that in cities of over 500,000 inhabitants any street railroad company may run and operate any portion of its road by electric or cable traction power, and lay and construct all the mechanical appliances thereof, upon receiving the consent of a majority in numbers and value of the owners of property obtained and filed in the regulated course.

STREET CARS, when first introduced in India, were unpopular; no one would ride in them, and for this reason: There are fourteen kinds of people, each with a distinctive social caste, and they hate each other like sin. Gradually the great saving of time and walking effected by the cars dawned on their minds and led them to stifle their prejudices so far as riding is concerned. The company appealed to their cupidity by running a lottery as well as street cars. Conductors were given little tickets with stubs, and were required to hand one to each passenger. Every ticket was numbered, and informed the owner that on the first of the month there would be a drawing with prizes. This brought passengers to the cars, and has done more to harmonize the population than thousands of missionaries could have accomplished.

The lottery is of advantage to them in another way. It prevents the conductors and drivers from robbing the company. Every ticket is of value to the holder, and the passengers demand them. They afford the best of records of the number of fares taken in.

"STRIKES must soon be abandoned," Senator Sherman declared to the labor people of Cincinnati March 26. And this is a very excellent time for members of the labor organization, to consider carefully and dispassionately whether strikes have not been sufficiently proved to be miserable and expensive failures. The official declaring off of the Boston street railway strike was a puny farce—after the strikers' places had been filled up, and they had lost everything and gained nothing.

"SOMETHING new in locomotives" has been exhibited in London, England. It is a new application of the valve motion, invented by a Mr. Parnell, and has been privately exhibited on a hundred-yards track, in Lambeth, to members of both houses of parliament and leading railway engineers of several nationalities. The engine is about half the size, half the expense, and far simpler than ordinary locomotives. If it will prove as effective in actual operation as it did at its private exhibition, it will revolutionize railway motive power, and will give portable steam new special advantages in competing with electricity and cables, etc., on street railways.

A NEW form of railway seat spring has been devised in England, and is highly spoken of. The entire seat is carried on a coiled spring of peculiar form, and is free to move in all directions, so that every jerk and oscillation which the car can receive is perfectly taken up.

THE famous engineer, Capt. Jas. B. Eads, died at Nassau, N. P., March 8, of pneumonia, aged 68 years.

ALTHOUGH the English Patent Cable Tramways Corporation (Ld.) has had a local habitation and a name at the Victoria Mansions, London, for some time, the town council of Birmingham have thought it prudent to secure a preliminary deposit at the rate of two thousand five hundred pounds (\$12,175) per mile "to pay for removing the cable rails," which are about to be laid in Birmingham, "if the system does not prove satisfactory." The cost of construction is estimated at about \$16,000 per mile. Truly our trans-Atlantic cousins are cautious. But it is satisfactory to observe that "such a contingency" as taking up the rails, etc., "is not apprehended."

## The Permanent International Tramways Union.

This Union was temporarily constituted at a preparatory assembly of European street-railway (tramway) representatives at Berlin, August 17, 1885; and permanently organized at a general meeting in the same city, September 24 and 25, 1886. The Union is founded for 25 years, and at the 25th general annual meeting it is to be decided whether the Union shall be prolonged; and, if so, for what length of time. The object is "to look after the technical and financial improvement of tramways, and to further the interests of the public and those of tramway companies in their relations with each other."

All tramway companies, their trustees, directors, superior officers and engineers, are eligible to become ordinary members, and companies have to pay a membership tax of 50 francs (\$9.88), while personal members' fees are fixed at 12½ francs (\$2.47). Those who "interest themselves in these conveyances" may become extraordinary members, and their annual subscriptions are the same as those of ordinary members; but they are not eligible for the directorship. For instance, The Tramways Union Company, Limited, London, is an ordinary company member; and Mr. A. Speé, engineer of the Company of Secondary Railway, Brussels, is an ordinary personal member; while the firm of Ibbotson Brothers, Globe Steel Works, Sheffield, is an extraordinary company member; and a representative of The John Stephenson Company, Limited, New York, may become an extraordinary personal member.

Mr. F. Nonnenberg is the General Secretary of the Union; and the central or general office is at 49 rue du Vantour, Brussels, Belgium.

## The Tramways Institute of Great Britain and Ireland.

The registrar of joint stock companies in England issued a certificate of incorporation to the Tramways Institute of Great Britain and Ireland, June 15, 1885, the company being "limited"; but the word "limited" is omitted from the title by license of the Board of Trade. The objects of the Institute are: (a) to watch and protect the interest of tramway companies; (b) to secure proper legislation in reference thereto; (c) to obtain greater facilities for, and to remove obstacles to, the development and prosperity of the tramway system; (d) to acquire and disseminate amongst members and associates of the Institute information relating thereto; (e) the discussion of such questions relating to tramways and matters pertaining thereto, as shall be proposed by any member and accepted by the council; (f) to afford legal or technical advice and assistance; and (g) generally to do all such other things as are conducive to the attainment of the above objects or any of them. The members of the Institute shall consist of tramway companies, lessees of tramways, and owners of tramways working their own property; and each such company, body, or individual may nominate such number of delegates to attend the meetings of the Institute as they may determine. The delegates so to be appointed shall consist of directors, solicitors, engineers, secretaries, or managers of tramway companies, or of such lessees or owners who are members of the Institute. The appointment of all delegates shall be subject to the approval of the council. Each member of this Institute shall, upon being admitted, pay an entrance fee of £2 2s., and an annual subscription of £1 1s.; also an additional £1 1s. for each delegate appointed. A guinea (£1 1s.) is equivalent to five dollars and eleven cents (\$5.11). Subscriptions shall be due and payable on the first of January. All persons favorable to the objects of this Institute may, on being duly proposed and elected, and on paying an annual subscription of £1 1s. or upwards, become "associates," and shall be entitled to attend all meetings of the Institute.

The first meeting of the Institute was held in London, July 17th, 1885. President Hutchison invited discussion on "the question of assessment as affecting tramways, as it appears to be the most clamant and pressing, and the evil

which most generally affects tramway interests throughout the kingdom." The discussion which followed showed great need of amendment. And Mr. Joseph Kincaid, M. Inst. C. E., pointed out the need of alterations in the relations of local authorities to the tramway companies.

The second meeting of the Institute was held in Birmingham, Oct. 28, 1885, when between two and three dozen of the principal tramways were represented. Steam traction on tramways was the special subject of discussion. Some spoke strongly in favor of the vertical boiler, in preference to the horizontal (or locomotive) type. The "weight of evidence," according to the report before us, was in favor of the "locomotive."

The Institute office is at 41 Coleman St., London, E. C. The Secretary is Mr. J. H. Duncan, F. C. A., of the firm of Duncan, Bryce & Co., chartered accountants.

## Cable Construction in Melbourne, Australia.

Mr. A. S. Hallidie, the well-known originator of the cable system, and President of the Cable Railway Co., of San Francisco, California, favors us with the following information (March 30):—

" \* \* \* I do not know if you are aware of what is being done in Melbourne. There they are building 34 miles of very substantial double track cable road, and will expend about five million dollars. The work is being very well done, under the direction of the engineer Mr. George Duncans, and about ten miles are already in operation.

"The financial management has been very successful. The Legislature authorized the city of Melbourne and suburbs to issue bonds for £1,000,000 at 4% for 30 years; these bonds, being guaranteed by Melbourne, sold at from 3 to 6 premium. The authorities issuing these bonds are called the 'Tramway Trust,' and are constructing the engine and car house, machinery and road complete and in running order. The 'Trust' has leased the whole system to a corporation called the Melbourne Tramway Company, for the term of the bonds, i. e. 30 years; and the company pay the interest, 4%, and a sinking fund of 2% per annum, which, at the end of 30 years, will redeem the bonds; it also equips the roads with rolling stock, maintains and runs the roads, and at the expiration of 30 years will turn them over to the city of Melbourne—free of cost, except for the rolling stock. The shares of the company have gone up enormously; and the lines constructed so far pay beyond expectation. I was there last year, and was very much pleased with the scheme and the manner in which the work was being done.

\* \* \* Will be glad to aid you in any way.

"Very truly,  
A. S. HALLIDIE."

THE metropolis of "The Golden State" is noted everywhere for her splendid system of street railroads operated by underground cables. There is probably no better street railroad in the world than the Market-Street line, in San Francisco. The cars are roomy and clean, run frequently and fast, the track is smooth and the fare cheap. Visitors here ride on these cars for the mere fun of riding. The several other roads in the city, combined with the different lines of this one, give access to portions of the city which were before their construction comparatively valueless. Large areas of land have been made available for residence purposes, and the growth of the city largely extended by reason of the presence of these roads.

The construction of the Powell Street cable railway, from Market to the bay, with a lateral system on Jackson St., is in good prospect, the building of the engine-house on the corner of Mason and Washington streets having been contracted for. This is the first step of what will probably be one of the most extensive cable systems in the city. The engine-house will cover a 50-vara lot, and will cost \$50,000, the plans providing for a building three stories high and entirely of brick. It will contain two Corliss engines of 800-horse power each, and will be surmounted by a chimney 150 feet high.



### Origin of the Word "Tramway."

The etymology of the term "tramway" excited much interest a few years ago. When the American Street Railway Association was incorporated, there was much discussion about a proper cognomination for it—some were in favor of calling it the American Tramway Association; but the name ultimately given it is the American Street-Railway Association. And on December 16, 1884, Mr. Augustine W. Wright, C. E., member of the Western Society of Engineers, read a paper before that society on the "origin of the word tramway," which is published in the Journal of the Association of Engineering Societies, Vol. IV., and therein it is clearly and conclusively argued that *tramway* was not derived from Mr. Benjamin Outram at all, as Tomlinson asserted. Tomlinson, however, is not the only one that has attributed the origin of tramway to the last syllable of Outram's name. Even Dr. Smiles, for one, says, in his "Life of Stephenson," that "the roads became known as 'Outram roads,' and subsequently, for brevity's sake, 'tramroads.'"

But when this matter is looked into closely, there seems a strong probability that the word tramway was not derived from the Derbyshire coal-owner's name. And Mr. Wright wonders "that the statement attributing the word to an abbreviation of his name has ever been allowed to stand unchallenged and uncontradicted." As he makes clear, tramways were known, by that name, long before Outram's time. It is recorded in Chambers's Information for the People (1842) Vol. I.—and the same is stated in the Engineers' and Mechanics' Encyclopædia (1838) by Herbert, to which Mr. Wright refers—that "the earliest railway, of which there is any account, was constructed near Newcastle-upon-Tyne. In Roger North's Life of Lord Keeper North, he says that at this place, in 1676, the coals were conveyed from the mines to the banks of the river, 'by laying rails of timber exactly straight and parallel; and bulky carts were made with four rollers fitting those rails, whereby the carriage was made so easy, that one horse could draw four or five chaldrons of coal.' One hundred years afterwards, about 1776, Mr. Carr constructed an iron railroad at the Sheffield Colliery. The rails were supported by wooden sleepers, to which they were nailed. In 1797, Mr. Barnes adopted stone supports in a railroad leading from the Lawson main colliery to the Tyne, near Newcastle; and in 1800, Mr. Outram made use of them in a railroad at Little Eaton, in Derbyshire."

After quoting further on this point, from Wood's Practical Treatise on Railroads, Mr. Wright observes,

"So far you will notice that his contemporaries give Mr. Outram no credit for any great prominence that would warrant the application of his name to the 'tramways.' His only improvement appears to have been the application of stone supports to take the place of timber, and Mr. Barnes anticipated him in this idea by three years. January, 1849, the Civil Engineer's and Architect's Journal (page 6) contained the following communication: 'SIR: In reading the article on George Stephenson, in the last number of the Journal, I noticed some errors connected with the description of the Stockton & Darlington Railway which I thought it would be well to point out to the writer of that paper, and to endeavor to correct them as far as I am able. Speaking of the Stockton and Darlington Railway, you say, "This could hardly be named more than a tramway." Now, from the very commencement, this line was a veritable railway. It could not properly be called either a tramway or wagon-way. In using those terms, we ought to be careful to apply them according to their proper and genuine signification, or serious errors may eventually creep into our descriptions of works of this class, and which may in course of time become perpetuated and the true meaning of the terms lost. Like railways, those three terms had their birth among the extensive collieries of Durham and Northumberland. The tramways are used principally under ground for the purpose of conveying the coals from the working district of the mine to the shaft up which they have to be drawn. In some of the extensive collieries, these tramways will extend for three or four miles. The gauge of the road is about 18 inches.

The carriage which runs upon this way is a small four-wheeled rolly or tram (hence the term tramway). Upon this carriage is placed the basket containing the coals. Previous to the introduction of tramways and trams, barrows were made for this purpose, the corf or basket being placed on the barrow, and a narrow flagged way for the barrows to run on was laid down, called the barrow-way, which term is even yet in some cases applied to the more modern tramway. It is, perhaps, 150 years since the barrow and barrow-way was superseded by the tram and tramway. \* \* \* The wagon-way is used for conveying the coals from the pit to the ships, etc. \* \* \*

After wagon ways came railways. \* \* \* From a long residence in the vicinity and particular acquaintance with the facts, I can vouch for the correctness of my statements.' I regret that the above was signed by a nom de plume instead of the writer's name. His definitions are corroborated by Smeaton, who, in a report to Lady Irwin, January 27, 1779, on the 'Measures of Coals at Newcastle and London,' used the following: 'And therefore, before the invention of the Newcastle rail or wagon-roads, all the coals that were carried down to the ships must have been conveyed on horses' backs.' And again: 'Since the invention of coal wagon-roads.'

"The words Tram, Tramway or Railway do not appear in Samuel Johnson's Dictionary. Worcester states in the preface of his Dictionary, 1846: 'To the words now added to the vocabulary, and not found in Todd's Johnson, an asterisk has been annexed.' Tram and Tram-road are so indicated—and defined, the former 'A sort of four-wheeled carriage or wagon, a car,' and the latter 'A road prepared for the easy transit of trains or wagons, by placing on its surface smooth beams of timber, blocks of stone or plates or rails of iron, as wheel tracks. It is a kind of railway adapted for the passage of vehicles with wheels of the ordinary form, for the conveyance of wood, coals, stone, etc. It is also called Tram-way and Truck-way.'

"Gillespie, in 'Roads and Railroads,' in 1847, states: 'Subsequently these wooden rails were covered with plates of iron; but the introduction of rails wholly of iron seems not to have taken place till 1767. A projection or flange on the outer side of the rails kept the wheels of carriages upon them. They were then called "tramways."'

\* \* \* \* \*

"Encyclopædia Britannica, under Railroads, says: 'The rapid wear of timber led to the structure of cast-iron to replace the wooden ones, and being limited in width, they were formed with a continuous flange or ledge on their inner edge to keep the wheels on the track. The roads were then called "tram roads," having been first laid down, it was said, by Outram, from whose name, omitting the first syllable, the word is said to have been derived. The derivation would apply equally well to the word trammel, the rail flanges being in reality trammels to gauge the road and confine the wheels.'

"Skeat, in his Etymological Dictionary of the English Language, 1882, states: 'Tram, a coal wagon, a carriage for passengers, running on iron rails. A tram is an old Northern word for coal wagon, especially such a one as ran upon rails. There was an act of Parliament for the year 1794 for the construction "of an iron dram-road, tram-road or railway" between Cardiff and Merthyr Tydvil. \* \* \* About A. D. 1800, Mr. Benjamin Outram made certain improvements in connection with railways for common vehicles, which gave rise to the silly fiction (ever since industriously circulated) that tram road is short for Outram-road, in ignorance of the fact that the accent alone is sufficient to show that Outram, if shortened to one syllable, must become "Out" instead of "ram" or "tram"; beside which, Mr. Outram was not a coal wagon. Yet Brecket's Glossary, third edition, 1846, explains that a tram is the Northern word for "a small carriage on four wheels, so distinguished from a sledge. It is used in coal mines to bring the coals from the hewers to the cranes." The word is clearly the same as the Lowland Scotch. Tram (1), the shaft of a cart or carriage of any kind; (2), a beam or bar. This notion is borne out by the cognate Low G. Tråam, a word particularly used for the handles of a wheelbarrow or the handles by

which a kind of sledge was pushed. Bremm Würberbach, edition 1771. J. H. Clarke notes that 'the amending of the highway or tram from the waste end of Bridgegait in Barnard Castle,' occurs in a will dated 1555. Here a 'tram' probably means a log road."

Mr. Wright then expresses the hope that the foregoing statements will prove "that the so often-accepted derivation of this word 'tramway' as derived from Outram is erroneous." And his own belief is that the word was originally condensed from "Trammle," after the indication to the same effect in the quotation here given from the Encyclopædia Britannica. "The word 'trammle,'" says he, "meaning 'to confine, to intercept,' as defined by Samuel Johnson in 1755, is a very old English word, and I suppose 'tram' was derived from it by dropping the last syllable, as the wagons were confined to or interrupted by the tracks; but wheresoever or howsoever the word did originate, it was not from Outram."

During the years 1882 and 1883 our technical journals were "devoting not a little space to this matter." And the revival, in the History of Street Railways, of "the silly fiction (ever since industriously circulated) that tram road is short for Outram-road," after Mr. Wright had exploded that idea, in 1884, has excited much attention.

It may not be out of place, perhaps, to suggest another probable origin, whence the word tramway may have been derived. Dr. Wm. Owen Pughe, in his Welsh Dictionary (published in 1832) defines—

Tram, *s. m.* (*tra-am*)=An extreme range round.

Tramwy, *s. m.* (*trani*)=A transit; a going about.

Tramwy, *v. a.* (*trani*)=To go about; to go often, to frequent; to pass over; to traverse.

These definitions are given without any reference to our modern tramways—they simply convey the sense of the Welsh words *tram* and *tramwy*, pronounced *trani'oo'*; and the verb *tramwy* means to pass regularly over the same path or way—backwards and forwards.

## British Tramways.

(Continued from page 33.)

London, of course, is the principal tramway centre in Great Britain. The North Metropolitan Tramway (in operation), is 38 miles long, London 20, South London 13, London Street 10, North London 8, West Metropolitan 8, Southwark and Deptford 5, and London Southern 4 miles—total 106 miles. The capital expended on these London street railways was £2,953,873 (\$14,248,346). The number of horses employed is 7,339; together with 14 locomotive engines—on the North London. Number of cars, 815; and also 52 omnibuses—32 on the London, and 20 on the South London Tramway Company's line. During the year, on the whole of these London tramways, 128,875,455 passengers were carried; and the aggregate net receipts amounted to £176,639 (\$854,933)—the gross receipts being £791,906 (\$3,832,825), and the "working expenditure" £615,267 (\$2,977,892).

As to length of track, these London tramways extend, in round numbers, to one eighth of the whole in the United Kingdom. The capital expended thereon is nearly a quarter of the whole. Nearly one-third of all the horses are on the London tramways; but, out of the 452 locomotive engines in use, only 14 are in London. This, of course, does not include the underground railways of London: these are left out of this reckoning altogether. London (and suburbs) has nearly a quarter of the whole number of cars. Of the total number of passengers carried, more than a third were in the London district. The gross receipts of the London tramway companies were more than one-third the whole; the working expenses were less than one-third the whole expenditure (throughout England and Wales, Scotland and Ireland), but more than three-tenths; and the net receipts were considerably over a quarter of the whole—being as 855 is to 2,946.

In reference to the London tramways, Duncan's Manual observes that "The Grand Berlin Tramway, which owns all the tramways in Berlin, carried during last year (1885)

77,350,000 passengers, and secured a gross revenue of £469,588 (\$2,272,806). As Berlin has barely a fourth of the population of London this shows very clearly not only the scope there is for extension in the metropolis, but how much more the benefits of tramways are appreciated abroad than in this country" (England).

It may not be out of place to interlard here, for the sake of comparison, what has been done in the city of New York (as a specimen of the work in the chief American cities, in proportion to their sizes), by way of passenger transportation, and place the figures of the three metropolitan cities in juxtaposition. The population of New York is but slightly more than that of Berlin—about a quarter that of London. Assuming that the increase in Berlin last year was the same (9½ per cent.) as during the previous year over 1884, the numbers of passengers carried on the horse railways of Berlin, the tramways of London, and the surface street railways of New York, during 1886, were—

New York.	London.	Berlin.
210,317,425	128,875,455	84,504,875

To that should be added 115,109,591 carried on the elevated railways of New York, and eighty and half millions conveyed on the underground railways of London.

Manchester, "the cotton metropolis," and district, follows London in the length of street railway tracks—over 82 miles, in operation. Capital expended, £912,296 (\$4,415,513). To this may fairly be added the Salford Corporation Tramway (as Salford is nearer to Manchester than Brooklyn is to New York), with 16 miles of tracks, on which £80,132 was expended, by the corporation; as well as £30,704, by the lessees, for 62 cars (£12,400) and horses (£18,304); total expenditure of capital, £110,836 (\$536,446).

In the Manchester district (including Salford) 3,067 horses were employed (during last year); with 71 locomotives, on the Manchester, Bury, Rochdale, and Oldham line, on which line also a loss of £2,552 (£12,315) occurred in the year's operations. Number of cars, 379; with "seven good wagons" (on the losing line). Number of passengers carried, 31,804,833. Gross receipts, £324,859; working expenditure, £245,116; leaving net receipts £79,743 (\$385,956).

Birmingham, with Aston on the east, and its western suburbs, is the third English street railway centre, in extent and importance. The Birmingham and Aston Tramway is close upon five miles long; Birmingham Central, over 2½ miles; Birmingham and Western Districts, nearly eleven miles—total length, 40 miles (not half as much as Manchester). These are the lengths in operation; extensions of the last two of these lines are authorized, to the further length of nearly 38 miles. There is also the North Birmingham Tramway Co., with a capital of £50,000 authorized to construct a line 3½ miles long; and the South Birmingham, with similar capital, authorized to lay 4½ miles of track.

On the lines in operation there were 875 horses, 105 locomotive engines, with 174 cars running. Numbers of passengers carried, 15,917,872; and the aggregate net receipts amounted to £29,557 (\$143,056).

The Liverpool Corporation has over 28 miles of tramways, with 13 more miles extending to Bootle, Walton, Wavertree, and West Derby. Last year they had 3,201 horses, with 168 cars and 98 omnibuses.

Birkenhead, where tramways were first introduced in England, has but 8 miles and 6 chains of track.

The shortest "tramway" in England is that at Scarborough, which is only 100 yards long, being merely a hoist from the sea shore.

## Personals.

Muscatine, Iowa, regrets the departure Mr. and Mrs. Orange J. Chapman; Mr. Chapman having resigned his position there in order to undertake the management of the Wichita (Kas.) street railway. "He is one of those careful, shrewd, far-seeing managers, who makes a success out of everything he takes hold of, if there is such a thing possible."

Mr. H. M. Watson, President of the Buffalo Street Railway Co., recently made a flying trip to New York, Philadelphia, and Albany.



## POINTERS.

## ALABAMA.

*Birmingham.* The Clifton Land Co. is building a line  $2\frac{1}{2}$  miles long, to be worked by dummies.

The East Lake Land Co. has awarded the contract for the street railroad to Patrick Sullivan, of Atlanta, Ga.; steam motors will be used.

*Decatur.* A street railway is to be built by H. T. Bond, and others.

*Tuscaloosa.* The Tuscaloosa & Castle Hill Real Estate Co. has let a contract to construct a street railway.

## ARKANSAS.

*Fort Smith.* A new street railroad company has been organized, and the old one has purchased more cars, etc.

*Helena.* A street railway company was organized here March 8, with \$30,000 capital—every dollar of which was taken before the meeting adjourned; and the work of construction will commence as soon as the rights of way are granted the company. Greenfield Quarles is president, S. H. Horner treasurer, and D. T. Hargraves secretary.

*Texarkana.* The Texarkana Street Railroad Co. has awarded the contract for building the line to the Texas & St. Louis Street Railway Construction Co., of Dallas, Tex.

## CALIFORNIA.

*Los Angeles.* The Rapid Transit Elevated Electric Railroad Co., capital stock \$700,000, has been incorporated by Gen. H. G. Rollins, T. R. Bennington, and others. The Enos electric system of suspended cars will be adopted.

*San Francisco.* Contracts have been awarded for a \$50,000 engine-house for the Powell Street cable line. The lower part will be for cars and machinery and the upper part for offices. There will be two Reynolds'-Corliss engines and six boilers.

The Telpherage Electric Railway Co. has been incorporated by Julius Loatz, F. M. Speed, R. A. Wilson, G. H. Hoppes and F. W. Brown.

## DAKOTA.

*Sioux Falls.* A street railroad franchise has been granted to R. F. Pettigrew.

## FLORIDA.

*Jacksonville.* The Jacksonville & Suburban Street Railroad Co. has been authorized to make alterations in its routes.

The Pine Street Railway Co. proposes to use electricity.

## GEORGIA.

*Atlanta.* Mr. Harry Hill is organizing a scheme for a belt street railway.

## ILLINOIS.

*Alton.* The Alton Improvement Co. has been incorporated to operate horse or cable railways; William Armstrong, Julius Raible, and others, incorporators. Capital stock, \$25,000.

*Chicago.* The statement has been published, from Maine to California, that the Chicago West Division Railway Co. has purchased the Chicago Passenger railway and its stock and equipments, better known as the Adams street line. This is not a correct statement: the line in question, which is 22 miles long, can not be sold to its great rival (the West Division Co.), nor consolidated with it, on account of a prohibitory clause in its franchise. What has really been done is this: 6,000 shares of the Adams street line have been purchased for \$900,000 by a syndicate in which prominent stockholders in the West Division are represented, including Messrs. J. Russell Jones, W. H. Ryder, Marshall Field, S. B. Cobb, W. H. Bradley, and B. H. Campbell. The road will be run independently of the West Division Co. Mr. Yerkes (President of the North Chicago Street Railroad Co.) and the Philadelphia syndicate (Mr. C. R. Cummings, Mr. W. B. Howard, etc.), were anxious to secure the road, and offered \$950,000 after the agreement with the other parties was signed, but were told they were too late. The certificates of the sold stock were owned by Messrs. M. C. McDonald, E. J. Lehmann, D. L. Hough, H. B. Peabody, and others. Harvey Weeks and E. R. Bliss retain their stock, and the former will continue to be President and the

latter Secretary; and the road will continue to run independently.

The franchise of the Arcade Rapid Transit Co. was thrown out by the City Council March 28. The Committee on railroads reported back the ordinance without recommendation. Twelve were in favor of granting the ordinance, and 12 were against. The objections raised were that the road would interfere with the sewers, and prevent the erection of a bridge over the river; a majority of property owners had not signed in favor of it, and the street would be in an impassable condition for five years. These objections were all contradicted. Ald. Simons feared that, as the tunnel would be below the low-water level it would be flooded in case of a freshet and the passengers drowned.

President Yerkes obtained the ordinance for the South Side loop-line, March 14. The company must "construct, maintain, and operate a street railroad" along the following-named streets in the city of Chicago: Monroe street, from LaSalle to Dearborn, with a single track; Randolph street, from LaSalle to Dearborn, with a single track; Dearborn street and avenue, from Polk to Michigan, with a double track; Fourth avenue, from 100 feet north of Polk street to 350 feet north of the same point, with a single track; Market street, with a single track from Illinois to Michigan street, continuing with a double track from Michigan to Kinzie; Kinzie street, from Market to State, with a double track; Division street from Clybourn avenue to Milwaukee avenue with a double track, and North avenue, from Clark street to Milwaukee avenue, with a double track. The city reserves to itself the right of ordering at any future time the construction of new bridges over the North Branch at Division street and at North avenue, in which case the company binds itself to furnish half the cost of them. The company must pay to the city \$500 per annum for the maintenance of these two bridges, and the lines may be worked by horse-power or by cable, as the company sees fit, with the exception of those on Division street, which must be worked by animal-power only. The tracks must be completed before July 1, 1888, except that on Dearborn avenue between Michigan and Lake streets, which must be completed six months after a bridge to be put across the river at Dearborn street shall have been opened to public traffic. The company is also obliged to permit its tracks on Dearborn street to be used by the Chicago City Railway Co. The tracks on Dearborn avenue between Polk and Michigan streets must be connected and operated by the cable road to be constructed on LaSalle street, and the cars must be run east by cable tracks from LaSalle to Dearborn street on Monroe and west from Dearborn to LaSalle street on Randolph by cable. The company is obliged by the ordinance to construct a new four-track iron bridge, to be operated by steam power, across the river at Wells street, the company at its option to remove the old bridge at Wells street to Dearborn or to construct a new one at that point.

A temporary injunction was obtained by Lawyer A. C. Story against the North Chicago Street Railroad Co. to prevent the laying of cable and tracks alongside of his residence. But President Yerkes "came out ahead" March 24, and Judge Tuley declined to continue the injunction, and the work goes on rapidly.

Van Buren street cars stopped running several hours March 14. Parties on California avenue had moved a frame house across the tracks and left it there. Assistant-foreman of streets O'Hare was blamed for the trouble. Similar delay occurred on Randolph street, the night before, by the breaking down of a large steam roller near Lake street bridge; and the additional cars that were consequently turned on Randolph street blocked the traffic for hours.

The Lakeside City Street Railway Co., Chicago, has been organized, and received its certificate of incorporation March 14. Capital stock, \$250,000. Incorporators, Samuel P. McConnell, C. H. Merrill, and Theodore P. Elliott. The purpose is to operate a horse or dummy street railroad in Chicago and its suburbs.

## IOWA.

*Council Bluffs.* The Lake Manawa Railway Co. has

a capital stock of \$100,000, with power to increase to \$250,000; the road is to be in operation by July. Among the incorporators are E. A. Benson, D. J. Rockwell, E. H. Odell, etc.

**Muscatine.** The officers of the Muscatine City Railway Co. are: Peter Musser, president; William Hoffman, vice-president; T. R. Fitzgerald, secretary; and Samuel M. Hughes, treasurer. The office of superintendent has been resigned by Mr. O. J. Chapman, and has not yet been filled up. Foreman F. Bloomer has charge of the equipments, etc. Length of track is 3½ miles. The company has seven cars, but now keep only four cars in motion. They use both horses and mules, and employ eight men, beside officers. The line has been in operation since September, 1883. The population of Muscatine is 10,000.

**Ottumwa.** The Court Street railway is to be extended half a mile. No contracts are yet awarded. R. T. Shea, president.

#### KANSAS.

**Atchison.** Colonel A. S. Everest and Frank Everest closed a bargain, March 10, with J. H. Beeson for the Atchison Street railway, the consideration to be \$75,000—\$10,000 more than the offer reported in the February GAZETTE. The property will be turned over to the purchasers April 15, and they will during the season extend the lines all over the city, and to the suburban additions which will be placed in the market this season. It is understood that California capital is behind the deal.

The Atchison Rapid Transit Street and Road Railway Co. has been incorporated by John Price, J. W. Parker, and others, with a capital stock of \$600,000; mechanical traction will be adopted.

**Burlington.** A street railway was to have been constructed here "in the early spring," but no progress is reported.

**Chetopa.** A charter for ninety-nine years has been granted The Chetopa Street Car Line Corporation. The road will be about two miles long. The officers are: George D. Boon, president; W. L. Sly, secretary; W. W. Edmundson, Joseph Craft, Richard J. Sly, directors. The amount of capital stock is \$5,000, divided into fifty shares of \$100 each. The same company have asked for "an amendatory charter," for additional lines.

**El Dorada.** Secretary R. H. Hazlett informs us that they are negotiating for material with which to build the street railway, and that they expect to have it built by the middle of summer. It will not take long to build it after once commencing. A mile and a half has to be completed by January 1, 1888. Street railway work is not to be pushed too rapidly in this modern El Dorada.

**Emporia.** The street railway of this city is to be extended considerably the ensuing summer.

**Girard.** Dr. G. T. Carpenter, who has been for some time projecting a street railway for this city, has received much encouragement, and the line is likely to be constructed.

**Hiawatha** is to have three lines of street railway—"the third line will run the entire length of Pottowattomie."

**Hutchinson's** Street railway "is being rapidly pushed to completion." The charter is for ninety-nine years. The corporate title is The Metropolitan Street Railway Co., of Hutchinson. Capital stock, \$50,000. Directors: G. W. Hardy, James H. Perkins, Hiram Constant, J. W. Mulky and A. H. Robinson.

**Lawrence.** The Lawrence Transportation Co. are going to put an additional car on their Massachusetts line, and will add half a dozen mules to their stock, which, President Tisdale thinks, may do better than horses, as the cars are 10 feet long.

**Leavenworth.** Captain M. H. Insley, Paul E. Havens, H. D. Rush, John Kelley and J. M. Graybill, of Leavenworth, D. B. Dyer, of Kansas City, and E. S. Rood, of Omaha, are the directors of the Leavenworth Street Railway Company. Capital stock, \$500,000, in shares of \$100 each. It is a motor line, to be constructed between the Penitentiary, Soldier's Home, the city of Leavenworth and Fort Leavenworth, and work will begin right away as soon as a survey can be made. Captain Insley says there is no doubt

in the world but what the proposed new line will pay, as the travel between the four points will be constantly on the increase. The travel now demands the constant running of forty or more hacks between the city and Fort, and the freighting between the city and Fort, the city and Soldier's Home, and the city and penitentiary, is enormous. The object of the new motor line will be rapid transit for freight and passengers. The charter calls for fifteen miles of road, and lateral lines will be run to the western limits of the city. Thousands of excursionists will be flocking here to visit the Fort and Soldier's Home in the summer season, and with the other business the hacks and omnibuses will be inadequate for their accommodation. The prices will be reasonable for both passengers and freight. The company expects to have the road in operation by the last of June.

**Lyons.** A company has been chartered to construct a street railway. The directors are: E. A. Deupree, Sam Steiner, C. W. Shumway, D. M. Bell, T. A. Butler, S. N. Smith, A. M. Lasley, J. E. Gilmore and Ed. W. Wood.

We understand that another company has been chartered here, but have received no report.

**Manhattan** makes but slow progress with its street railway enterprise. "The company is quietly at work agitating that question. Twenty-eight shares have so far been taken. The officers express a determination to take active steps in the matter the coming summer." There is thus a great contrast between this and another Manhattan—with regard to passenger transportation.

**Minneapolis.** A street railway company has been formed here, and \$20,000 is paid in, to build "a surface railroad or dummy line," 3¼ miles long, and forming a complete circle, and taking in the most beautiful elevation in the valley.

**Oberlin.** The Oberlin Street Railway Company has been organized. Capital, \$50,000. Directors: R. A. Marks, Everton Doom, H. M. Lippincott, W. A. Burnett and R. G. Doom.

**Olathe.** Mr. Ogg has organized a street railway company, to run a line between Fort Scott and Southern Kansas depots.

**Ottawa** is to have a street railway

**Paolo.** The City Council passed an ordinance March 10, granting the Paolo Street Railway Company a thirty year's franchise to build a line of street railway on any of the streets of Paolo. Work is to be begun within a year, and before the expiration of two years the railway is to be completed from the depots to the city park. The company is composed of S. D. Condon, J. H. Phillips and E. W. Robinson, "three enterprising citizens, who will push matters as rapidly as possible," we are assured.

**Stafford.** The new street railway company here intend to have just one mile of their road in operation by June 1st. Cars have been ordered.

**Topeka.** The Sixth Avenue and Deer Creek Street Railway Company has been organized by Guilford Dudley, B. F. Golden, W. D. Alexander, Harvey D. Rice, Albert Knowles, C. O. Knowles, W. Edson, T. J. Kellam, T. A. Beck, George W. Watson, T. C. Rowles, C. K. Holliday, C. S. Gleed, O. H. Brown, J. F. Scott, George T. Gilmore, M. A. Pond, H. E. Ball, etc. The road is intended to be run by either steam, electricity or other motive power, and is intended to give accommodation to the citizens living in the additions east of the city. It is intended to build this road at once to accommodate the demands of the great boom that has taken possession of east side property within the last few weeks.

Jesse Shaw, Superintendent of the Topeka City Railroad, declares that his company will spend \$50,000 within the next few weeks on extensions of their system. They have now a large force of men pushing as rapidly as possible their new line on Sixth street. "We mean to keep up with the boom," says the superintendent. "We are now building a double track across the Union Pacific Railroad in North Topeka, and before many weeks a double track will be put down from Gordon street to Garfield Park; and by the way the city railway company will expend several thousand dollars in a short time in improving Garfield Park; we propose to make it as fine a summer resort as there is in the



state. No doubt other extensions of our street car line will be made, but I am not prepared to say just now where they will be."

The Highland Park Circle Railway Company has been incorporated, with Major Hudson at its head. The first three miles, from the city to the east line of Highland Park, "will be built, equipped and operated before December 1st." Much of the grading in the park avenues has already been done. And with the twenty teams and forty men now at work the tree planting may be finished, and streets completed, by the middle of this month (April). Major Hudson states that, "It will be a steel rail narrow-gauge road, and operated with a dummy steam engine, making trips every hour from 6 a. m. to 9 or 10 p. m."

**Washington.** A street railway company has been organized here and right of way applied for.

**Wichita.** The Wichita city railway, which has now fifteen miles of track, is to be considerably extended forthwith. The franchise thereof has been sold by Major Powell to a syndicate for \$200,000. About fifty mules are to be sold, and "heavy horses" put to work in their stead.

**Wyandotte.** Preparations are being matured for the vast extension of Wyandotte's street railway system. The Brighton Hill and Chelsea Park Railway Company has been incorporated, with a capital stock of \$100,000; the directors being D. M. Edgerton, Daniel D. Hoag, Winfield Freeman and Winston Barrett, of Wyandotte, Robert Gillham, of Kansas City and L. G. McNair, of St. Louis. This company's line will begin at Garret street, Wyandotte, and follow the line of the Kansas City, Wyandotte & Northwestern to Ninth street, where it will bear to the south. Its western terminus will be Chelsea Park, about a mile west of the city of Wyandotte. It will be a dummy road, and its entire length will be about two miles. Further particulars of the street railway prospects of Wyandotte are indicated under Kansas City, Mo., and elsewhere in this issue.

#### KENTUCKY.

**Louisville.** "No city of its size in the world has half as many miles of street railroads as Louisville, Ky." Its population has increased from 123,000 in 1880 to nearly 200,000 in 1887, it is computed. The city has 144 miles of paved streets, and some ninety-four miles thereof are used by street railway companies. Then there are three miles of elevated railway, and twenty-two miles of steam suburban railroads. All these carried 20,697,000 passengers last year at an average fare of less than five cents. The Louisville City Railway (64 miles) carried 11,897,000; the Central Passenger (30 miles), 7,000,000. The Daisy line is six miles long, and the Jeffersonville Transfer ten miles. The Daisy Belt Line (six miles) is in course of construction; and the Belt Line (ten miles) is authorized.

**Paducah.** The Paducah Street Railway Company has been organized; the contract has been let to S. R. Bulloch & Co., of New York City, who will complete the line by August.

#### LOUISIANA.

**New Orleans.** The Committee on Public Order has reported that the right of the New Orleans Elevated Railroad Company has expired by limitation, no steps having been taken to make use of the privileges. An ordinance has been introduced to repeal all others in favor of the company.

#### MAINE.

**Bangor.** D. F. Longstreet and Joshua W. Wilbour, of Providence, R. I., have been in the city in the interest of the proposed electric railway.

**Biddeford.** The Biddeford and Saco Horse Railroad is to be operated by animal, electric or cable power.

#### MASSACHUSETTS.

**Boston.** The Metropolitan Railway Company have petitioned for a location for a third track on Fremont street from Sterling to Ruggles street, and connecting with the tracks already laid in the street named.

The Consolidated Railway Company have been urged to run cars regularly on Medford street.

The Riley Elevated Railway Company has opened an office and exhibition room at 93 Milk street, where models and drawings can be seen. These are of a very superior

character in workmanship and high finish, allowing visitors and enquirers to examine the smallest details to gain a full understanding of the system, and of the advantages claimed for it. President F. A. Bartholomew is manager.

The statement that all the street railroads of Boston have been consolidated is not true. The West End Land and Railway Co. have sought control of the Metropolitan, South Boston and Cambridge Street railroads. If they succeed, and when the West End line is constructed, they will have nearly 200 miles of tracks, and will accommodate people in some fifteen cities, towns and districts: Somerville, Cambridge, Arlington, Watertown, Newton, Brighton, Brookline, Roxbury, West Roxbury, Dorchester, Milton, South Boston, East Boston and Chelsea, being already reached by the street railroads now constructed in Boston. Lines run to all the parks, every railroad station, all the ferries and every place of amusement, besides every part of the city. The termini of the various out-of-town lines point to still further extensions where, by building a mile or less of track, extensive districts can be reached. The idea seems to have originated in a big real estate movement reaching out over Beacon street, to Brookline and vicinity. The stock was placed on the market a few weeks ago at \$13 and it soon reached \$25 per share. The rumor of the proposed consolidation sent the stock up still higher; and possibly the "great combination" was nothing but a rumor invented by speculators to "boom" the stock.

Boston is likely to have some practical electric street railway work on a large scale very soon.

The first electrical railway in the city will be started over the East Boston Sugar Refinery Company's yards, running from the water front up into the refinery to convey sugar in bulk. The motive power, says the *Electrical World*, will be an Armington and Sims Company's engine, and the dynamo will also be used to run incandescent electric lights in the night.

**Cambridge.** The Meigs Railway is still on exhibition at East Cambridge, and is receiving much attention from city and State officials.

The necessary legal permission and authorization have been granted for the construction of a railway on this plan, and the road is now in course of construction. Everything has been done to prove the feasibility of this peculiar system.

**Taunton.** The Taunton Street Railroad Company will extend its tracks.

#### MICHIGAN.

**Detroit.** The Dix Avenue Electric Street Railroad Company has been granted a further time of two months to perfect its motor.

The Grand River Avenue Street Railroad Company will extend its track one mile to Broadway.

The Highland Park Company have ordered an additional Fisher Electric Motor of sufficient capacity for a train of three cars, and they have ordered two more cars.

#### MINNESOTA.

**Duluth.** The Duluth Highland Cable Railroad Co. has been incorporated by J. A. Willard, of Mankato, and others; capital stock, \$200,000.

**Minneapolis.** The Minneapolis West Side Street Railroad Co. has been incorporated by Randolph Burgess, J. T. Byrnes, A. Chamberlain, H. J. Mitchell and M. Walsh. Capital stock, \$200,000.

A street railway will be built on Franklin avenue.

Two new lines of street railroads are to be built, as extensions of the old tracks—one to extend 13 blocks, and one about 40 blocks.

**St. Cloud.** A street railway company has been incorporated here, to construct and operate a street railway in St. Cloud, East St. Cloud, and Sauk Rapids. Capital stock, \$50,000. Incorporators, C. P. McClure, A. G. Whitney, O. W. Baldwin, R. L. Gale, L. Troutman, F. Tolman.

#### MISSISSIPPI.

**Columbus.** A street railway is to be built here at once.  
**Greenville.** Cars for the new street railway were shipped from St. Louis March 30.

## MISSOURI.

*Independence.* The Citizens' Street Railway is being extended from Kansas City to its elevated eastern suburb. Cars have been purchased from New York, and rails have been procured from St. Louis. The work of grading will soon be followed by the laying of the ties and rails. The railway will, according to the franchise granted by the Board of Aldermen, go east on College street and the Lexington road until the line of Independence avenue extended is reached, when it will take a direct eastward route. The line eastward from Liberty street, on the line of Independence avenue, has been temporarily abandoned on account of the narrow street from Main to Vine street not having been properly dedicated to the city. Proceedings will be instituted to secure the proper opening of this street and its widening. The street car stables are to be located on the east side of Main street, between Maple street (not avenue) and Turner street. The city line will be in operation within three months.

A street railway is projected by D. C. Imboden, etc.

*Kansas City.* The cable railway companies are making preparations to take advantage of the first favorable weather to complete their new lines. The Troost avenue line is already far advanced, as is also the Fifteenth street line, both of which will be completed early in the summer. The material for the Grand avenue line has been ordered, and much of it has arrived. The company expects to complete the road to Westport by January next.

The Metropolitan Company's Fifth street line is completed to Mulberry street, and the material for the completion of the road to Wyandotte has been ordered.

The People's Cable Railway Company has been organized—capital stock, \$750,000—to build the Tenth street and Brooklyn avenue cable line, for which the franchise was granted to B. F. Jones, Henry N. Smith, jr., and others, of Kansas City; but they sold it to Mr. J. Foster Rhodes, of Chicago, who afterwards transferred it to a company composed of prominent Chicago capitalists. Among the stockholders are the following: Albert Cowles, business manager of the *Chicago Tribune*; W. F. Blair, one of the directors of the Merchants' National Bank of Chicago; John F. Black, J. H. Rhodes, of Cincinnati, O.; Charles A. Mair, a prominent grain dealer of Chicago; John Vance, W. R. Shaw, Caleb H. Marshall, J. M. Phillips, of Memphis, Tenn.; Walter Brown, of Kansas City; D. H. Burnham, of Chicago, J. Foster Rhodes and others. The directors are: C. F. Dwight, W. P. Rice, O. H. Dean, Walter Brown, W. F. Blair, J. H. Rhodes and J. Foster Rhodes. The officers are: J. Foster Rhodes, president; C. F. Dwight, vice-president, and W. P. Rice, secretary and treasurer. Work will be commenced on the road at once, and it is expected that the line will be completed within the year. The road will be constructed according to the latest and most approved methods, and will be first class in every respect.

The contracts for the Metropolitan Twelfth street cable line have been awarded in two sections, of \$125,000 each, to Bernard Donnelly and William H. Faulkner, who are to complete the work by September 1st.

The Kansas City Cable Railway Company propose to increase their capital stock from \$700,000 to \$1,500,000.

*St. Joseph.* A. Steinacher, Henry King and Theodore Steinacher, principal owners of the Union Street Railroad, went to New York and other cities for the purpose of buying electric motors for their line. After inspecting the various systems of electric railways, as found in operation in all the principal cities where the electric motor is used in propelling street cars, they contracted with the Sprague Electric Railway and Motor Company for electrical equipments for the Union road, together with all the latest appliances. The company expect to surpass results reached by any of the electric roads so far built, including the lighting of cars by electricity; and they also expect to run their cars at the rate of from ten to twelve miles per hour.

*St. Louis.* A new system of cable railways has been invented by Richard P. Walsh.

The Electric Light and Power Company, of St. Louis,

will soon apply their Trippe storage battery system to propel street cars in the city.

## NEBRASKA.

*Grand Island.* The Grand Island Street Railroad Company has been incorporated by O. A. Abbott, W. A. Hogge, A. B. Thompson and others, to operate a line by horses or motors. Capital stock, \$100,000.

*Lincoln.* An electric motor company has just been organized in Lincoln, the object being to operate a passenger road from the business part of the city to the Stock Yards, the cars to be propelled by electricity. The capital stock is \$100,000.

*Norfolk.* The Norfolk Street Railroad Company has been incorporated by J. S. McClary, W. A. Rainbolt and others. Capital stock, \$50,000.

*Omaha.* The Omaha and South Omaha Street Railway Company has been incorporated, to traverse different routes in the southern part of the city. The capital stock is \$100,000, and the incorporators are William A. Paxton, John A. Creighton, Peter E. Iler, Meyer Bellman, John H. Bossler, S. W. Allerton and Isaac E. Corydon.

The United States Court has decided that the Omaha Horse Railroad Company has no exclusive franchise.

The Omaha and Benson Street Railroad Company has been incorporated by C. E. Mayne, Erastus Benson and W. L. McCague; work has been commenced.

The Omaha and Southwestern Street Railroad Company has been incorporated by H. Ambler, S. J. Howell, Cyrus Martin, C. Wooley and C. T. Harrison; capital stock, \$15,000.

The Omaha Horse Railroad and Cable Railroad Company has been organized by the Omaha Horse Railroad Company to convert the system to cable.

*Plattsmouth.* A street railroad is to be built.

## NEW HAMPSHIRE.

*Manchester.* The Manchester Horse Railroad Company will build an extension to South Manchester.

## NEW JERSEY.

*Orange.* The Orange Crosstown and Orange Valley Street Railroad Company is constructing its line. The Daft electric section will be in operation by May.

There is trouble over the crossing of the tracks of the Orange Crosstown Horse Railroad and the Orange branch of the Greenwood Lake Railroad. The horse railroad company laid the tracks, and the other company tore them up. The courts will be appealed to. The railroad company offered to permit the tracks to be laid if the horse railroad company would station a watchman at the crossing, which the latter would not do.

## NEW YORK.

*Binghamton.* The Washington Street, State Asylum and Park Street Railway has brought to this city a great quantity of ties, poles, etc., and has hired a large force of men to make preparations for the electric apparatus which is to be immediately applied to that road.

A new street railway running east on Hawley from Washington north in Exchange and east in Court to the Asylum, is to be built. It will probably be equipped with electric power if a trial proves it a success.

*Brooklyn.* The Brooklyn and Suburban Street Railroad Company has been incorporated by Henry H. Adams and others, with a capital stock of \$900,000. The line will run from Bedford avenue to Flatlands, with a branch to the Holy Cross cemetery.

The Coney Island and Brooklyn Railroad Company is petitioning for power to run locomotives along the Coney Island plank road.

The Court of Appeals has decided in favor of the right of the Kings County Elevated Railroad Co., and work will be commenced at once. This will interfere with the line of the Union Elevated Railroad Company.

The Park avenue cable line has been started

*New York.* The New York Underground Railway Company, through their contractors (the U. S. Underground Construction Company) have secured full permission, from the Commissioner of Public Works, to open up Lafayette place in order to construct there the first portion of its pro-



posed underground electric railway, under the Vandenberg charter. As mentioned in the February GAZETTE, Edward Lanterbach is the president of the underground railway company, and J. Coleman Drayton is the president of the construction company, which has now embodied the plans of Col. Rowland R. Hazard. The most important feature of the plan is that the excavation in the street will be only nine and a half feet deep, when completed. This does away with all danger of injury to the foundations of buildings. The trucks of the cars are to be placed at the end instead of under the cars, as is customary. Each car will be virtually a suspension bridge resting on the trucks at each end, and it will be constructed for the precise purpose of resisting the pressure which its center would be subject to. The distance from the top to the bottom of the car will be eight feet, thus leaving about a foot below the bottom and six inches above the top in the underground space. There will be four tracks, two for express and two for way trains. As each track will be partitioned off, each of the four tunnels thus made will be self-ventilating.

The route, so far determined, runs from the City Hall to and up Elm street to Lafayette place, and thence up Fourth avenue to the Grand Central depot. Two 300-horse power engines have already been ordered from the Rhode Island Locomotive Works, Providence. The Bentley-Knight electric system is to be used, and Col. Hazard says, "I think that our experiments justify me in saying that we have found an electric motor which solves the question of the application of electricity to the railroad problem."

In connection with this underground railway the projectors have far-reaching plans in contemplation, to unite all the railroads in one terminus near the Empire City. The plan is, first to establish an immense union railway terminus at Morrisania. Thousands of acres of land are to be bought there and used as the largest depot and switching grounds in the world. The New York Central and Hudson River, the New York and Harlem, the New York, New Haven and Hartford, and the New York City and Northern railways, which now pass in the vicinity of the spot designated for the union terminus, will stop there. The Grand Central Depot, at Forty-second street, will be abandoned.

The Arcade railway will, in the mean time, have been built under Broadway, from the Battery, and the Underground (connected therewith) will be running to Forty-second street, and will take possession of the tracks now reaching thence to Harlem River, and run right into the Morrisania general terminus. The Suburban Rapid Transit line, and other railways to be built on the northern shore of the river, will also run there. All the lines entering Jersey City, Hoboken, Weehawken and Newark are also to be brought into the same terminus. To do this a great six or eight-track trunk line is to be built from a point on the Hackensack river, back of Jersey City, directly parallel with the Hudson river, but at the distance of two miles from it, passing to the west of Hoboken, Weehawken, Edgewater and Fort Lee, to a point nearly opposite Washington Heights. Here the road will turn to the east and cross the Hudson river on a great cantilever bridge, which, like everything else in this scheme, will be built on a scale of unprecedented magnificence. From Washington Heights, which will be the eastern end of the bridge, the road will pass across the island to the Harlem river, which will be spanned by another great iron and steel structure, to Morrisania and the great union terminus.

More remains to be told, great as the scheme is so far. Beside all that, the entire shore of Manhattan island will serve as the route of a great elevated railroad for the distribution of freight. All the great warehouses will be placed along the line of this road. Each warehouse will have its own switch, and will load and unload cars under its own roof. The elevated freight road will be connected with the Union line to Morrisania, where it crosses the island. Warehousemen will be able to load their own cars and ship them through without change to San Francisco, if they want to. Sending trucks to freight depots for goods will be done away with.

Some property owners in Broadway have organized

themselves to oppose the projected underground railway in that famous thoroughfare, and they have expressed themselves in favor of an elevated railway in the street, especially if some propelling power other than steam may be adopted. They state that the immediate need of more means of rapid transit is the direct cause for their willingness to have an elevated road in that thoroughfare. If cable, traction or electricity should be the motor force, and if the structure should be wholly of steel, with no wooden cross-ties to obstruct the light, with the tracks placed over the centre of the street and the pillars at the curbstone, those gentlemen say that they would favor the building of such a road.

O. B. Potter says, "Such a structure to my mind, would afford precisely the kind of rapid transit which Broadway needs; it would make it possible for business men to go up and down Broadway with rapidity and ease, whereas it is impossible to do so now in the surface cars in that part of the city where it is most needed by business men. I own a good deal of property in Broadway and I think that such a road would benefit the property and the street, making it a great business thoroughfare. I think that it would greatly help to solve the rapid transit problem in this city, and I believe that a majority of the property owners favor such a road."

General Wingate, counsel of the Metropolitan Rapid Transit Company, says that the company will soon be ready to construct such a road.

The elevated railways are to be considerably extended forthwith in other directions also.

The American stockholders of the Bombay Tramways Company at their meeting in this city March 1st, decided to re-organize with increased capital. They find that, although the Calcutta Tramways Company (Limited) declared no dividend last year, they made a profit of \$3,151 during the year, and had, with previous earnings, \$19,383 available for dividend; and that, therefore, street railways will soon pay in India.

The bill authorizing another bridge or tunnel, higher up the East River than Brooklyn Bridge, is not favorably received by the authorities of New York City.

Mayor Hewitt last month appointed five Rapid Transit Commissioners to determine what increased facilities for rapid transit are needed in the city, and to lay out the necessary routes.

The contract for the steam plant, to furnish power for the Fulton Street Electric Railway, New York, has been awarded to the Jarvis Engineer Company, Boston. It will start with one steel tubular boiler set with the Jarvis furnace to burn screenings for fuel, a 100 horse power Armstrong & Sims Company engine, heater, pump and injector.

*Oswego.* Manufacturers and others urge the Improvement Society to get electricity for street cars and other purposes.

*Rochester.* The R. C. & B. R. R. Co. have ordered ten two-horse cars of the Pullman Palace Car Co., to be delivered in May. Secretary Woodworth informs us that some extensions are contemplated which will necessitate another new barn and car-house, during the coming summer.

*Rome.* The Rome Street Railroad Co. has awarded the contract to the Edward Barr Co., of New York, for construction. The road will be finished by July.

#### NORTH CAROLINA.

*Durham.* A contract for two miles of the new street railway has been let to A. H. Holland.

*Wilmington.* The Wilmington Street Railroad Company has been incorporated by F. H. Stedman, Isaac Bates and others; capital stock \$25,000.

*Winston.* A street railroad scheme is on foot.

#### OHIO.

*Cincinnati.* The Mount Adams and Eden Park Inclined Railway Company has increased its capital stock from \$100,000 to \$300,000.

The Cincinnati Street Railroad Company will extend the John street line to Price Hill.

*Columbus.* The Third and Schiller Street Railroad Company has been incorporated by P. E. Blesch, Julius A. Kramer, Henry Mithoff, Conrad Herman and Charles Engelke. Capital stock \$25,000.

*Lima.* An electric railroad three miles long, on the Van Depoele system, is to be established. Address B. C. Faurot.

## OREGON.

*Portland.* A street railway is projected to the suburbs on the east side of the Willamette river.

Other street railway schemes are "in the air."

## PENNSYLVANIA.

*Allegheny.* An electric railroad is projected by O. P. Scaife.

An incline railway will be built up Nunnery hill by Arthur Kennedy.

*Harrisburgh.* An electric railroad is proposed, and a committee has inspected the Van Depoele road at Scranton.

*Philadelphia.* The ordinance authorizing the Metropolitan Railroad Company to build an underground line has passed the Council.

The Lehigh Avenue Railway is being constructed at last, track laying having commenced on Broad street. The charter of the company was secured in 1873, but nothing was done in the way of constructing its tracks until last year, when the charter changed hands, and permission was given by Councils to lay tracks and operate the line. The road will be built with double tracks from end to end, the western terminus being directly at the entrance of Laurel Hill Cemetery. Permission has been secured from the Board of District Surveyors to build a bridge over the Reading Railroad tracks at Broad street, and to go under the Connecting Railroad near Twentieth street. A controlling interest of the stock was sold last year, and a new company organized with the following officers: President, Joseph T. Bunting; Directors, William Rotch Wister, John Wister, Langhorn Wister and James P. Booth. W. Horton, Jr., is also interested. The capital stock of the corporation is \$600,000, divided into 12,000 shares at a par value of \$50.

President Ackley, of the Thirteenth and Fifteenth Street lines, Phila., had a fire in the stables of his company lately. It originated in the hay loft, and succeeded in damaging nearly \$3,000 worth of property before it was subdued. Owing to the coolness and promptness of the officials of the road all the horses were saved by being turned into a large shed or car house. Mr. Ackley states that they have no means of ascertaining the immediate cause of the fire, but believe it to be of incendiary origin.

*Pittsburgh.* The Pittsburgh and East End Railroad Company has been incorporated by Wm. L. Chalfort, John Bissel and others. Capital stock \$250,000.

*Scranton.* M. G. Clark will extend his new electric railway to Dunmore.

## RHODE ISLAND.

*Woonsocket.* The contract for the new street railway has been let to local contractors, and the cars will be running by July.

## TENNESSEE.

*Chattanooga.* The North Side Street Railroad Company has been incorporated by G. W. Thompson, Geo. W. Ochs, and others.

The Chattanooga & Missionary Ridge Street Railroad Company has decided on a change of route. The capital stock will be increased from \$30,000 to \$100,000.

*Decatur.* A street railroad is being built by the Land Improvement Company.

*Knoxville.* A street railway company was organized March 12, by Wm. Caswell, A. N. Jackson, S. R. Rodgers, E. P. Camp, J. A. Swan and T. A. Moses. It is intended to construct and operate a couple of miles of street railway to the northern suburbs of the city.

The stockholders of the Knoxville Belt Railway have elected W. R. Tuttle, president, Samuel House, treasurer, and J. W. S. Frierson, secretary. The work of construction will commence at once. The capital stock is \$100,000.

The Knoxville Street Railway Company will extend its line about a mile.

*Memphis.* The East End Street Railway Company has been incorporated by Wm. Sneed, H. M. Neeley and others.

*Murfreesboro.* The Murfreesboro Street Railroad Com-

pany—capital stock, \$100,000—has been incorporated by J. L. McKnight, W. M. Bell and others.

*Nashville.* The Hyde's Ferry Street Railroad Company has been incorporated by G. L. Ellinger and others.

The Overland Railroad Co. (O. L. Noel, president) will build a street railway and operate it with dummies.

About thirteen miles of belt railway will be built.

## TEXAS.

*Dallas.* The council has passed an ordinance authorizing the street railroads to consolidate for 25 years, under certain conditions. This has put ten miles under one management since March 15. The consolidation comprises four companies—the Belt Line, Ervay Street, Main and San Jacinto. The Belt Road of 7 miles was built and cost (3 years ago) \$28,000 complete; sold, Jan. 1st last, for \$80,000. Half interest in the Main & San Jacinto sold about the same time for \$40,000. Flippen, Addon & Lobit, bankers, Oliver & Griggs, bankers, and Royal A. Ferns, vice-president of the National Exchange Bank, all of Dallas, are the principal and heaviest stockholders.

The North Dallas Railway Co. has begun operations.

*Sherman.* A street railroad is to be built by H. A. Burnett, within six months.

*Waco.* The Waco Street Railroad Company has purchased rails for a three mile extension; \$20,000 will be spent on new buildings.

## VIRGINIA.

*Danville.* A street railroad company has been organized.

*Richmond.* The council has permitted the Richmond City Railroad Co. to extend its tracks, and has granted a franchise to the Richmond Union Passenger Railroad Company.

*Roanoke.* The Roanoke Street Railroad Company has been incorporated. President, Thomas Lewis; Secretary, F. T. Brinkley. Capital stock about \$100,000.

## WISCONSIN.

*Milwaukee.* A franchise has been granted for a street railway on Broadway, to the Lake Shore depot.

## New Books, Pamphlets, Etc.

The Riley Elevated Railway System illustrated catalogue is to hand. The Riley Construction Company have opened a new office at 93 Milk Street, Boston, in addition to their New York office at 39 Broadway.

The Safety Electric Railway and Power Company (Daft system) have forwarded their illustrated catalogue, together with a special report of the operation of the Daft electric railway at Los Angeles, which is now being extended.

*Union Internationale Permanente de Tramways.* We return thanks to Mons. F. Nonnenberg for a large package of pamphlets, being reports in English, French, and German of the organization of the Permanent International Tramways Union, of which he is the Secretary.

*The Meigs Elevated Railway.* The Meigs Company, of 30 Court Street, Boston (whose system was described in the March GAZETTE), have issued a new catalogue (of 182 pages) wherein is explained the reason for the departure of the Meigs Elevated Railway System from the ordinary practice, and how and why a safe railway is possible.

## Business Notes.

Rochester City & Brighton Railroad Co.,

Rochester, N. Y. March 23d, 1887.

Car Track Friction Appliance Co.—*Dear Sirs:*—Yours of 22d came to hand as did the letters send by you. We received sand boxes in due time and had them put on car, and have been waiting to see how they worked. We are now able to say that they have worked very satisfactorily so far, and believe they will prove to be a good thing.

Respectfully Yours, (Signed) T. J. BROWER, Supt.

THE Way Foundry Co. of Philadelphia is under contract to supply the North Chicago Street Railroad Co. with 150 30" pulley wheels, for the new cable extension.

It has also a contract to supply all the curve conduit castings for the Public Building Improvements of the Philadelphia Traction Co.



# The Street Railway Gazette.

VOL. II.

CHICAGO

MAY, 1887.

NEW YORK

No. 5

## American Cable Railway Construction.

BY AUGUSTINE W. WRIGHT.

PART I.—Continued from page 75.

Running into the engine house, he found that the rope, having been freshly tarred, was slipping on the drum that set the rope in motion. The application of a little lime and sawdust, with some pressure upon the rope, set it running again, and shortly the increased speed of the engine told

Kearney street, and extended to a point near Van Ness ave., about one mile, passing over a hill at an elevation of 307 feet. The accompanying figure 9 shows a profile of the road. The latter is crossed by ten streets, and at these points the grades are nearly level. Clay street is only 49 feet wide from house to house, and closely built up. This site for the experimental line was chosen because it reached the highest point of Russian Hill, and presented all the difficulties which were likely to be encountered in any other street. On account of the steep grade of the street, property

### ISOMETRICAL VIEW

### OF ROAD BED

WITH GRIP AND PART OF SHANK.

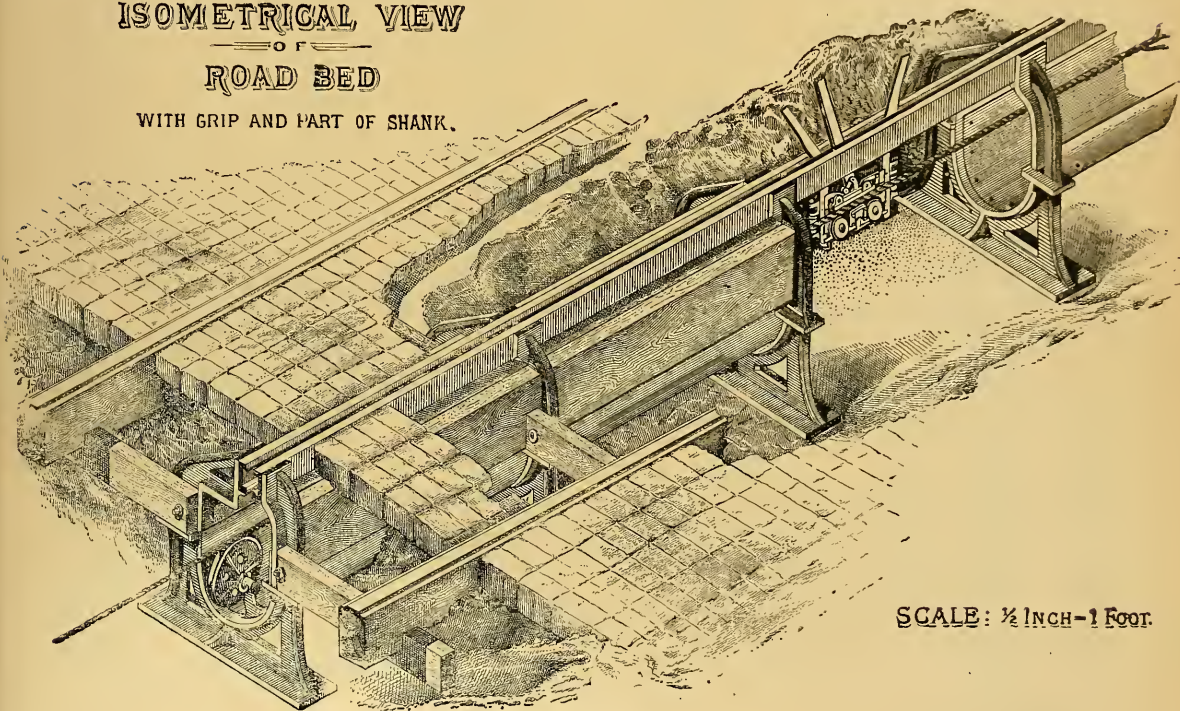

SCALE: 1/2 INCH = 1 FOOT.

FIG. 10.

him that the public trial had been made—the car and dummy were once more on top of the hill, and the thing was pronounced a success.

Like all new inventions there were still a great many changes and alterations to be made before all the difficulties could be overcome; but Mr. Hallidie and his friends were encouraged to continue the patient and persistent efforts which have finally resulted in making the San Francisco cable railways so celebrated.

This road began at the intersection of Clay street with

on the hill was almost inaccessible, and numerous projects had been suggested to reach it by zigzagging up the hill by routes that would have been not only tedious and slow, but very expensive.

#### CONSIDERATIONS INVOLVED.

Various considerations and conditions had to be carefully weighed before venturing upon a project which involved, not only the expenditure of a large sum of money, but the comfort of the citizens and the safety of human lives. The

ordinary traffic by wagons and carriages on the street could not be interfered with, and the surface of the street was required to be left in the same condition as before, with no obstruction or impediment to travel or traffic. No posts or poles would be permitted in the streets, nor would the authorities allow any locomotive or exposed motor that might possibly explode or frighten horses. It was also required that the cars should be under control, so that they could be stopped and started at any point along the route as quickly as with horses. The speed was limited; not less than three, nor more than eight miles per hour. The fare for a single passenger was not to exceed five cents for the entire distance.

To meet these requirements, many difficulties presented themselves. The street grade being broken and uneven, if a wire rope were employed, it must be confined above as well as below, otherwise it would fly up into the air several feet above the street surface at the crossings, when the grade suddenly changed from a level to a rise of 1 in 6½, and if kept down a roller or pulley must be employed on top of the rope inside the tube; and this would be in the way of anything passing down from the car to the rope. Another consideration was that the climate of San Francisco

The wire rope inside the tube runs the entire length thereof, up under one track and down under the other, passing into the engine house, when it takes turns around a driving pulley of peculiar construction, motion being given to the driving pulley by means of a steam engine, and thence imparted to the rope. At each end of the cable road, *i. e.*, at each terminus the rope passes half around a large hori-

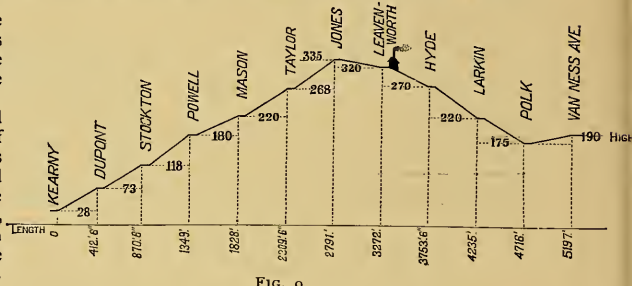

FIG. 9.

zontal sheave, from one tube to the other, said sheaves being eight feet in diameter. The rope is supported every 39 feet on 1 1/2 inch sheaves, and at every change of grade at the lower crossing in sheaves four feet in diameter.

In the accompanying figure 10, is shown a tube or channel of one track. It will be seen that the yokes of cast iron, four feet apart on the steep street and three feet when

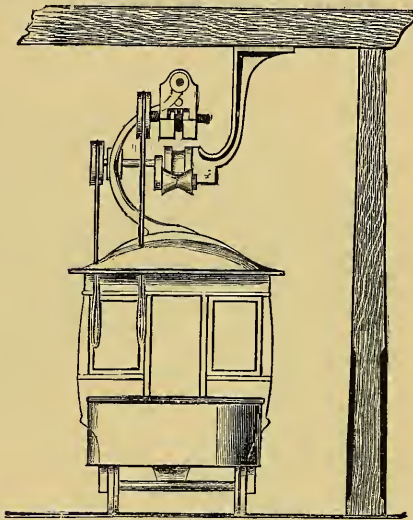

FIG. 7.

has long and heavy rains from October to April, and if a rope was used in an underground tube, the opening in the tube top should be placed sufficiently on one side of the rope to allow grit and sand washed in to fall without coming in contact with the rope. Any opening into the tube must be too narrow to permit the entrance of any vehicle wheel. Another difficulty was encountered in the transmission of power from the engine to the rope. By the ordinary way there would be required two deeply grooved sheaves, around which the rope would have to be wound a number of times. The unequal wearing of these grooves would strain the cable and wear it rapidly. Many other minor considerations, quite considerable in the aggregate, had to be faced and overcome.

The following is a description of the Clay Hill street railway, the first cable railway ever constructed:

The surface of the street has the same appearance as with a horse car line, except that in each horse path there is an opening extending the entire length of the road, about 3/4 of an inch in width. Below the surface there is a channel or tube about 20 inches deep by 14 wide, large enough to contain pulleys, rope and grip. This tube is to protect a steel wire rope moving inside, supported on pulleys, and the working parts of the grip, that connects the rope with the car by a shank passing through the aforementioned slot.

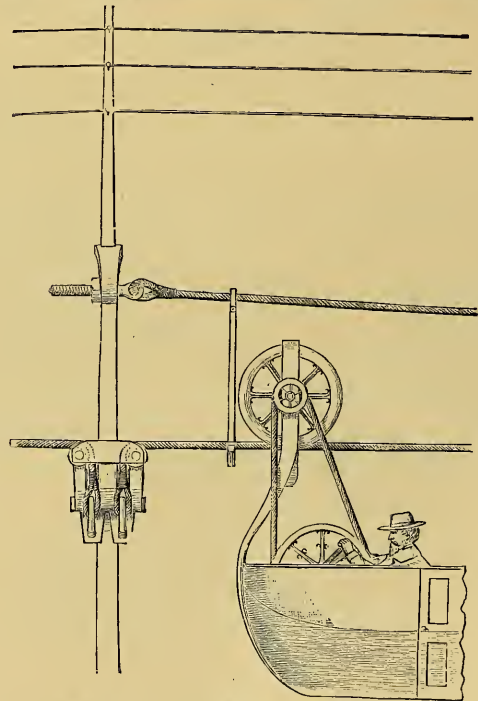

FIG. 8.—WATER HYDE'S ELEVATED RAILWAY.

traffic was heavy, carry a cross-pin of wood ballast to the side of the yoke at one end and fastened to the track stronger at the other end. To this the slot rails are fastened at its top. A carrying sheave is shown in the foremost yoke. The sides of this tube are formed of plank; a portion of the grip, with its shank broken is also shown.

THE GRIP

constituted an important element in the success of the road,



as did also the method by which it should be supported, and its position in relation to the passenger car. The objections to placing the gripper in the car were, that it would occupy valuable passenger room, and it would destroy the symmetry of the car; cutting it in two, as it were. The

passenger car, that it could be easily uncoupled when necessary. This carriage was called a dummy.

Fig. 11 shows a section through the dummy and the road-bed, with the position of the grip on dummy and in conduit. On this road the slot opening was not equi-dis-

### SECTION THROUGH DUMMY & ROAD BED

SHOWING CABLE AND GRIPPING ATTACHMENT

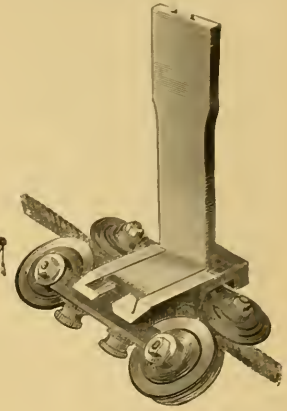
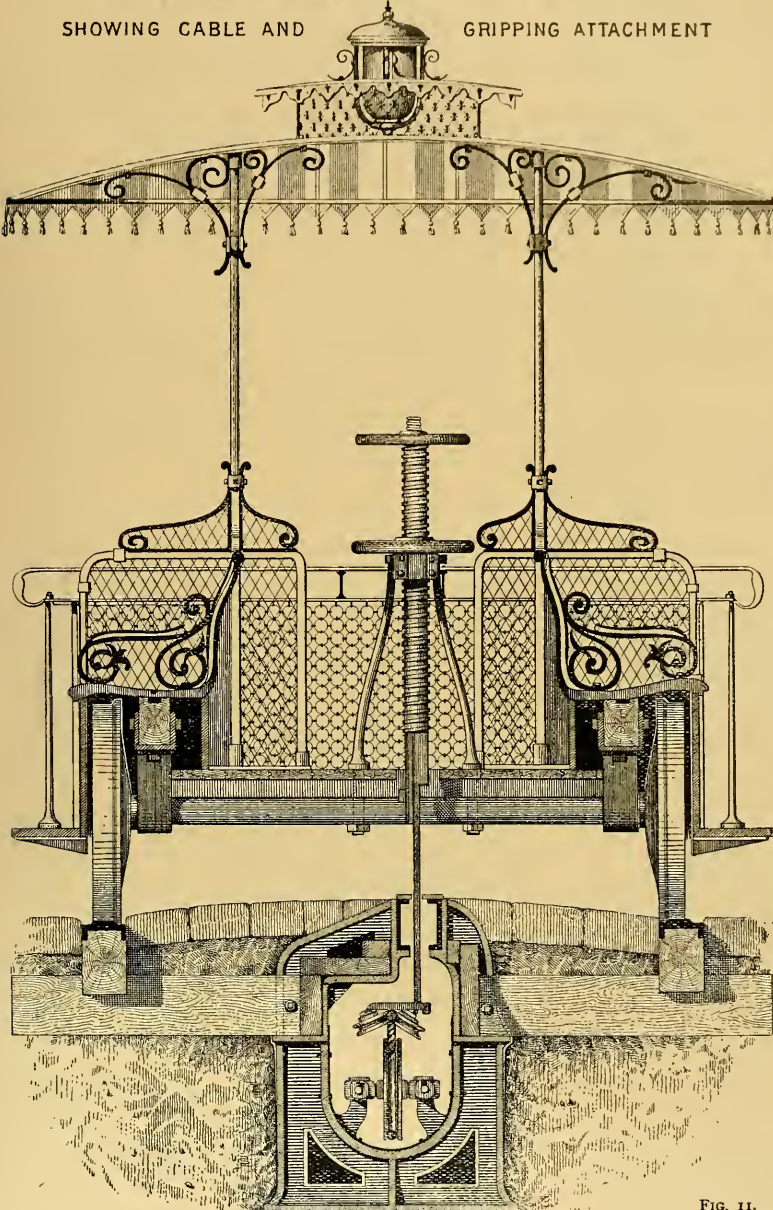

FIG. 12.

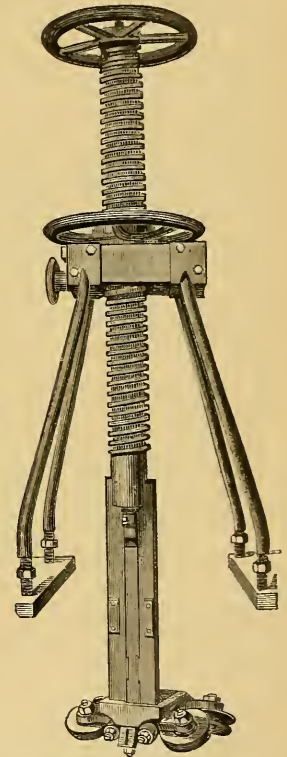

FIG. 13.—THE HALLIDIE CABLE GRIP

look-out of the man in charge would be interfered with in an enclosed car, and if the car was continued beyond the termination of the cable, an unnecessary dead weight must be carried with it, unless the gripper was removed, which would create delay and annoy the passengers. A carriage was contrived to carry the grip, and to be so connected with

stant from each track rail, but the cable was. The slot not being directly over the cable permitted any water, dirt or sand to drop to the bottom of the conduit without coming in contact with the cable, and the grip shank passed straight down through the slot, the cable being grasped on the side by a heel or off-set.—(To be continued.)



## Mechanical Traction on Street Railroads.

NOTES ON EXPERIMENTS IN EUROPE, 1870 TO 1880.

BY R. E. RUSSEL TRATMAN, JR. AM. SOC. C. E.

(Continued.)

*Paris (France).* In August, 1876, steam power was employed on the street railroad from the Mont Parnasse depot of the Orleans Railroad to the Austerlitz bridge, and in February, 1887, was extended thence to the Place de la Bastille, a total distance of 4.5 miles. The road was wide and had not a great amount of traffic, except between the Place and the bridge; the steepest grade was 1 in 40 for 800 yards, and the line contained curves of 98.5 feet of radius. The track was standard gauge, and consisted of 40-pound rails of grooved section spiked to wooden stringers; the groove was too small to cause inconvenience to road vehicles and no trouble was experienced from its clogging, a special and inexpensive machine being used to clean it. There were 24 Merryweather engines, costing from \$2,250 to \$2,500 each, and weighing about 8,960 pounds in working order; the steam pressure was limited to 150 pounds; the length of engine and car was about 27 feet, not longer than a car and horses, and the train could be stopped in 8 yards on a down grade at maximum speed. From 8 to 10 engines were in use daily. The first engines were too light and were replaced by heavier ones; some of the later ones were built by the Fives-Lille Company. The cars were of the ordinary street railroad type, seating 48 passengers and weighing 13,440 pounds loaded; the outside seats were protected by closed ends and a roof, above which the engine smoke-stack reached. The maximum speed was 12 miles per hour, and the average 6 miles. The authorities were satisfied with the results and other steam routes were proposed, horses were substituted for a time on the original route in order to make a comparison of results, which proved so favorable that other routes, aggregating 10 miles, were authorized to employ steam power. The rules of the municipal authorities regarding the emission of smoke and steam were very stringent. In 1879 the engines were taken off the line from the Place de la Bastille to the Mont Parnasse depot in consequence of the bad conditions of engines and track. In the same year there were four other lines, belonging to different companies, worked by mechanical power.

(a.) From the Arc de Triomphe to Courbevoie, 3 miles. The track was laid on a footpath between the main road and a side road to the houses; it was nearly level. Separate engines, built by a Swiss firm, hauled trains of two cars successfully.

(b.) From Place Moncey to St. Denis, 4 miles. The streets were wide and there was a grade of 1 in 25 for 600 yards. Separate compressed-air engines were employed, being on the same system as at Nantes, except that, the cars being larger (capacity for 50 passengers) a separate engine was adopted; the engine had four cylinders, three for general use, and one as a reserve to be used on the grade. The speed on suburban roads was 20 miles per hour.

(c.) From Reuil, on the St. Germain Railroad, to Marly, 10 miles. This was a suburban line, and for part of its length was laid along a footpath. The track—standard gauge—was laid with ordinary railroad metals. Fireless locomotives were used, the boiler being supplied with high pressure steam from a reservoir, which was located near a grade of 1 in 15 so as to ensure the engine having full power to ascend it; the engine gave off as much steam as a railroad locomotive.

(d.) From the Orleans Railroad to the suburb of Villejui, .75 mile. This line was worked by a Hughes engine, which had been exhibited at the Paris Exposition; its performance was satisfactory, and no steam was emitted. The cost for horse traction in 1877 was 14 cents per car mile.

*Rouen (France).* Steam was first used in September, 1877, working a line along the quays and out to the suburbs, a length of 4.5 miles, through a not very populous part of the city. The road was wide, and the track was laid at the side, leaving 9 feet between rail and curb. The engines

were built by Merryweather, and by Fox and Walker (Bristol, England); on Sundays they hauled two cars as far as the octroi barrier, but beyond that only one, there being a grade of 1 in 28 just beyond. Later a line was worked from the quays to the suburb of Maromme, 6 miles; an additional length of 1.25 miles into the center of the town and also a branch about 1 mile long from the original steam line, from which branch engines were soon withdrawn, however, in consequence of complaints as to the escape of steam. The engines ran at a speed of from 12 to 15 miles per hour on suburban roads, ascended a grade of 1 in 22 with ease, and, descending, could be stopped (with dry rails) in about 20 yards by the engine brakes alone. The inspecting officer of the Board of Trade (England) reported in 1879 that little care seemed to be taken to prevent the escape of steam, as much being given off as by an ordinary locomotive.

*Strasbourg (Alsace Lorraine).* In 1879 lines were operated by steam power from the suburbs of Rheinbruck and Hohnheim to the city gates, horses being employed within the city. On the latter line the road was in some places only 20 feet wide. The engines were similar to those on the Paris Courbevoie line and hauled two cars; on Sundays and fêtes days four cars were hauled.

*The Hague (Holland).* The line connects with the Dutch Rhenish Railroad and runs to Scheveningen on the coast. For two thirds of the distance it runs on the high road, but for the other third the railroad company purchased land in order to make a more direct line. Steam-cars were used, and their performance was very satisfactory.

*Utrecht (Holland).* A street railroad company instituted competitive trials of engines by different builders in May, 1879.

### LOCOMOTIVES.

*Grantham.* This system was for a combined engine and car or "steam car." A car built for use in Vienna was experimented with in 1877 on a street railroad from the Woodside ferry, Birkenhead (opposite Liverpool), to the Holylake railroad depot, a distance of about three miles. The grade from the ferry was 1 in 14, and after ascending this with some difficulty, a speed of 25 to 30 miles was attained as an experiment. The boiler was vertical, placed in the middle of the car, the cylinders underneath, also in the middle. The car was carried on two 4-wheeled trucks and weighed about 13,440 pounds. A car on this system was tried in Paris about 1877. At Wantage (England) this system was also employed for a time; the first car had two small boilers, one on each side of the middle passage, but though this arrangement worked well on a level line in London, on the Wantage line, with grades of 1 in 50, there was not sufficient steam power and a large Shand and Mason boiler was put in by Messrs. Merryweather, the builders: an improved car on this line had the boiler in the middle, dividing the car into two compartments which were entered from the ends and were used for 1st and 2nd class. The machinery was outside but boxed in; steam was cut off automatically at a speed of 10 miles per hour and the driver worked the engine from the front platform. This engine satisfied the Board of Trade as to absence of steam, smoke and noise, but not as to the power of controlling the speed. The car was about 25 feet over all and had a capacity for 20 inside and 30 outside passengers.

*HUGHES.* The steam engines of this system were separate from and independent of the cars, and were first tried in Leicester (England) in 1876, where one was run on a line about 4 miles in length, including a grade of 1 in 22, at a speed of from 6 to 9 miles per hour. Another engine was tried in Edinburgh at the end of the same year, but though it hauled traffic on the steepest grades it was not heavy enough for regular use. In March, 1877, seven engines were in course of construction for the Vale of Clyde line. On the Wantage line the steam was condensed in tanks, with entire success in good weather, and in rough weather there was not enough escaping steam to be an annoyance. In Paris, 1878, they worked over grades of 1 in 35 and a maximum grade of 1 in 20, their speed about 10 miles per hour on the level and they could be stopped in about 20 feet; the smoke escaped toward the ground and there was no draft in the stack. These



engines weighed 10,640 pounds empty and 13,440 pounds in working order (an extra 2240 pounds were recommended for the Edinburgh engines), with cylinders 7 inches by 12 inches, and working pressure from 100 to 150 pounds per square inch. Later engines weighed from 14,560 pounds to 15,680 pounds. The average cost was \$3,000 or \$3,500 according to size, etc. The condensing water was automatically measured and the back pressure from condensing chamber was 2 pound per square inch; large heating surfaces were employed, giving slow combustion. They could condense all the steam on a ten mile trip, and could run that distance without any firing. Their ordinary load was one car carrying 40 passengers, but on occasion they could haul two cars, except on steep grades. The engines have been tried in Bristol, Edinburgh, Glasgow, Leicester, Sheffield, Belfast, Dublin, Bilbao, Cologne, Hamburg, Hanover, Paris, Dunedin (New Zealand), and elsewhere.

**MEKARSKI.** This was a compressed air system adapted for a combined car. A car was worked experimentally at Paris in the fall of 1876. No machinery was visible; the compressed air cylinders were under the car body and the air was passed through a "regulator," containing hot water, fixed on the front platform. The cylinders were charged at a pumping station, the operation occupying a long time. The maximum pressure was 12 atmospheres, but on one journey, made for an inspecting officer, it did not exceed 4 atmospheres. The car ascended a grade of 1 in 18 with ease, stopping and starting on the grade, and a speed of 20 miles an hour was attained, the engine being under perfect control, and was said to be very quiet and easy running. Mr. Harding, of the Paris street railroads, thought it would be very desirable if reliable, but it was uncertain and expensive and had not always power to complete its journey. It has been tried in London within the last few years.

**MERRYWEATHER.** This system is one for separate and independent steam locomotives. Previous to March 1877, engines had been running in Paris for 14 months—9 regularly, the rest experimentally, and were then reported to be working daily. The average speed was 8.5 miles per hour, including stopping and starting, though a speed of 12 and 14 miles per hour were sometimes attained; steam could be shut off automatically at any desired speed, beyond the control of the engineer. The engines weighed about 6,720 pounds, and could haul 2 cars on a fairly level road. The boilers were of the ordinary tubular type and the exhaust steam was passed through a cold air tube condenser and what was not there condensed passed on to the water tank; by another method the exhaust was turned into the tank until the temperature of the water was 200° F., when it required to be changed; if this could not be done the steam was blown into the firebox, no trouble being experienced therefrom if plenty of air was blown in with it. The engines were tried at Batley, Leytonstone, Portsmouth, Wantage, Paris and elsewhere.

**SCOTT-MONCRIEFF.** This system was for a combined car driver by compressed air. It was experimented with in 1877 on a short length of railroad near Glasgow, with a maximum grade of 1 in 100, at a speed of about 8 or 10 miles per hour; and in the same year it was found too heavy, and carried insufficient power to work on any section of the Edinburgh street railroads. In the same year it was tried on the Vale of Clyde line for a short time. It was charged every 3 miles, though there was a margin of about 30 per cent. of the pressure at the end of that distance. The working pressure was 310 pounds, and at the end of the three miles was usually 100 to 110 pounds. There was no noise from the exhaust as the air had reached atmospheric pressure at the end of the stroke. The working cylinders were 6 inches in diameter, with a stroke of 1.4 inches, and no inconvenience was experienced from the cold, resulting from the expansion of the air. The air was compressed at pumping stations, and the car was charged by means of a hose, the time occupied being from 2 to 2.5 minutes, the same as for changing horses. The cars had inside and outside seats, were about 23 feet 6 inches long over all, and carried 40 passengers.

(To be continued.)

Steel Toe Calks.

The accompanying engravings illustrate the patent steel toe calks, sharp and blunt, for horse-shoes, that were first

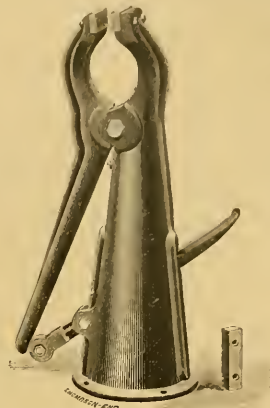

FIG. 1

brought into notice and manufactured by the Messrs. Charles D. Dewick and P. F. Burke in 1868. The latter succeeded the Messrs. Dewick in 1886, and is now actively engaged in the manufacture of this specialty, and the improvement of machinery required for rapid and satisfactory production. The annexed cuts represent different sizes, as "one prong blunt," "one prong sharp" and "two prong blunt," etc. "One prong blunt" has an extra size suitable for the California market.

The horse shoe is first heated, and the toe calk then welded in. The triangular spur shown in the cuts is the piece that is driven into the shoe and secured to it by welding. The toe calks are manufactured from stock carefully selected with regard to welding and hardening. The spurs are claimed to be sharper and better-placed, and the body of the calk more symmetrical than those of other manufacture.



Fig. 1 represents Burke's Improved Horseshoe's Foot Vise, which is operated by a treadle, and is self explanatory, on reference to the engraving. The works of P. T. Burke

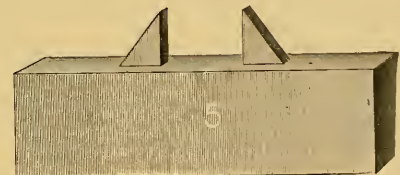

at 360 Dorchester avenue, South Boston, Mass. are furnished with excellent tools of a strong and durable character for drilling, shearing punching and bending iron and steel;

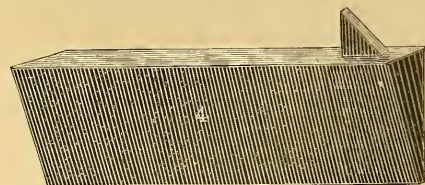

and as workshops for the manufacture of specialties of this kind, they are models that reflect much credit on good taste and mechanical skill.

### The Meigs Elevated Railway.

On reference to pages 52 and 53 of the STREET RAILWAY GAZETTE (March, 1887), a general idea may be obtained of

Fig. 3 represents the Meigs truck, showing the general method of construction. On the left-hand side a portion of a double-flanged wheel is used to show the utter absurdity of such a wheel.

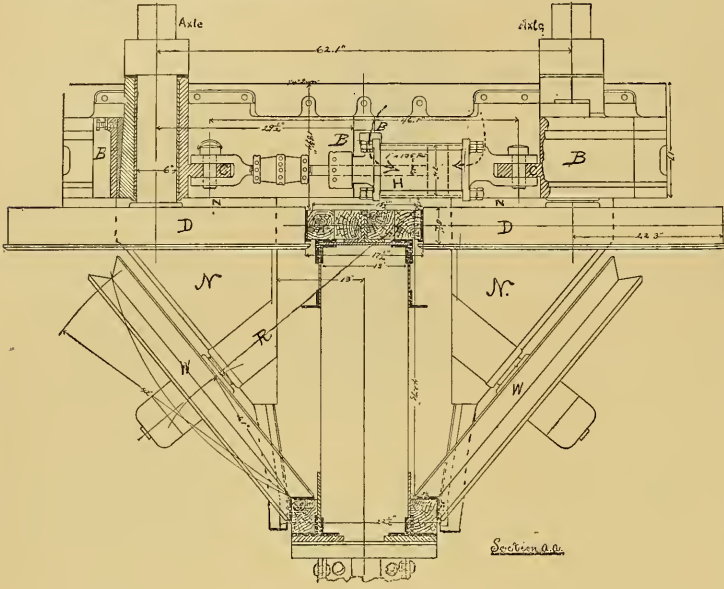

FIG. 1.

the form of car and track used in the plant of the Meigs railway system, which is a departure, original and peculiar. In the latter part of the present article, we give the names of the officers of the Meigs Elevated Railway Construction Co., of East Cambridge, Mass., and here present our readers with some fuller information relative to parts and details of the plant.

Figure 1 represents the arrangement of driving wheels, and some of the machinery under the locomotive boiler, and also the supporting-wheels on the track. It will be at once observed that the driving wheels are placed horizontally, not vertically, as in the usual form of locomotives; and that the supporting wheels are placed at an angle. Reference being made to the drawing, fig. 1, D D, are the driving wheels, B B, sliding-boxes carrying axles of drivers, upon which cranks are placed, H, hydraulic cylinder, into either end of which liquor can be let under pressure so as to pull the drivers on the track or push them off, N N, front jaws of truck beyond drivers, carrying the supporting-wheels W W, which always receive the load super-imposed whether balanced or unbalanced' by a right thrust.

Fig. 2 shows a cross-section of a Meigs railway cylindrical car; its dimensions, seats, truck attachment, turn-table, and the spring-boxes attached to it, and its kingbolt. For clearness the draw-bar and lower part of truck-frame straddling the lower rail are left off.

N, jaws attached to platform of truck to carry axle. G, lip fastening turn-table to top of truck. B and C, spring boxes. — — — dotted lines through axles, shown as radial lines leading from the upper rails, about which side thrusts must turn trucks, thrusting engendered force down centre lines of wheels.

Fig. 4 represents a cross-section of a street, showing that the Meigs railway does not disturb light and air; that it presents the least cross-section of any railway, and that its trucks, astride of the track 48 inches, render its cars absolutely safe against derailment, even at a moment of collision. The track is an open post-supported girder, 17 1/2 in. x 22 1/2 in. at its widest part overhead, and but 50 inches in depth.

We have already, in a former number, referred to the track and rolling plant of the Meigs railway at East Cambridge, with which the severest tests have been made. Repeatedly have the exhibition and experimental trips been thrown open to engineers, railroad officials, experts, scientists, and the public.

At one of these recent exhibitions, the writer took his position on the locomotive, and witnessed the following

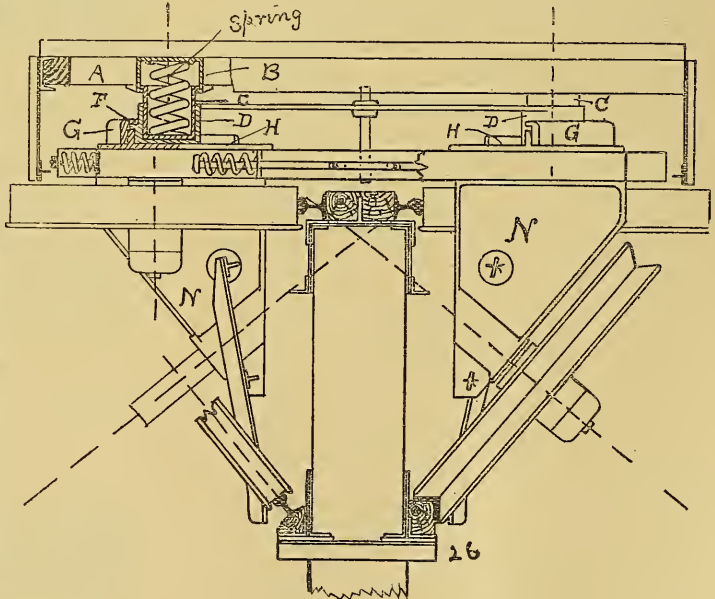

FIG. 3.

performance. The engine, after leaving the horseshoe curve, proceeded for a short distance on a level straight, and came to a 50 foot curve by grades of abrupt change





## Construction, Equipment and Maintenance of American Street Railways.

BY AUGUSTINE W. WRIGHT.

(Continued from page 69.)

The contractor must have a competent foreman on the ground at all times during working hours to attend to the work and receive the instructions of the superintendent. Sub-contractors will not be recognized.

The contractor must take down and remove all inferior or defective work or materials upon being directed so to do by the superintendent, at any and all times, within 24 hours after receiving notice to that effect. But if the contractor shall neglect or refuse to take down and remove said imperfect materials or work, then the owner or superintendent shall have power to take down and remove the said imperfect work or material and replace the same with such as are in accordance with the plans and specifications, at the cost and charge of the contractor.

### EXCAVATION.

Excavate the ground for all foundations to the depth marked or shown in the plans. After using so much as may be required by the superintendent, the surplus, if any, shall be removed from the premises.

### STONWORK.

The foundations under each pier shall be of dimension stone eight inches thick, in one piece 4' X 4'.

The foundation under all walls shall consist of large flat-bedded rubble, well and thoroughly laid, so as to break all joints. It will be 3' 0" wide and 16" high. Above this height to the top of stonework the walls will be 24" wide at the bottom, tapering to 16" at the top. The walls are to be built to the height marked or shown in plans or sections, and laid in cement mortar; the interior to be filled solid with spawls and mortar, leaving no interstices. The top to be perfectly level and straight.

### STONE.

The stone used to be the best quantity of limestone, flat-bedded and nearly equal thickness and subject to the inspection and rejection of the superintendent.

### MORTAR.

The mortar for stone work will be composed by measure of one (1) part Utica or Louisville cement of best quality to two (2) parts of clean lake sand, and mixed in small quantity as needed. Retempering will not be permitted.

The lime mortar shall be made of clean sharp lake sand, thoroughly mixed and incorporated with fresh burned quick lime in proportion by measure of two (2) parts sand and one (1) part lime.

### BRICK.

The brick used shall be good, hard burned, straight and true, and free from lime. They will be subjected to a rigid inspection, and all soft or defective or inferior brick rejected. All bricks shall be well wetted before used and shall be laid perfectly plumb and straight, well banded and tied together in band of five (5) courses of stretchers to one (1) course of headers. The joints and all interstices shall be flushed full with mortar, leaving no voids or empty spaces in the walls. The joints on the outside and inside of all unplastered walls shall be neatly struck. Arches shall be built over all openings, inside and outside. Bed carefully and solidly all door and other frames, and underpin all sides with mortar. Cover up all work during inclement or wet weather. Do all necessary cutting and build all cornices or other projections in the best and most workmanlike manner.

### LATHING AND PLASTERING.

The office, conductors, and grooms rooms will be lathed with sound 1 3/8 inch pine laths, 3/8 inch apart, and firmly nailed to each bearing. Joints broken once in six (6) courses.

Plaster the sides of walls with two (2) coats of mortar. The first coat to be of hair mortar well floated, and the second of clean sharp lake sand and plaster of paris, troweled down perfectly smooth. Ceilings will have three (3) coats of mortar.

### CUT STONE.

Each pier shall be covered with a limestone cap, sawed top and bottom, 6" X 17" X 17". Each post shall set on a sawed limestone plinth, 10" X 10" X 17".

The window sills shall be sawed limestone, 5" X 8" X 4' - 0". Three door sills weathered 6" X 20" X 3' - 4".

362 lineal feet of coping will be 3" X 24", and 362 lineal feet 3" X 12", all sawed and no piece less than 4' - 0" in length.

There were 649 cubic yards of excavation, 1824 square feet of dimension stone, 56 cords of rubble, 473 thousand brick, 114 band stones, and 114 plinths, 72 window sills, 3 door sills, and 724 lineal feet of coping in the above building.

The plinths upon which the posts set are quite essential, for it is at this point that the posts first rot, if carried to the floor level. By keeping the top of these stones, and consequently the bottom of the posts two inches *above* the floor level, this rotting is prevented.

### CARPENTER WORK.

The following are:

#### *Specifications for Carpenter Work.*

Stable for North Chicago City Railway Company, Jay street and Belden avenue.

### GENERAL CONDITIONS.

The contractor must give his personal attention and superintendence to the work; must furnish all transportation, labor, materials, and apparatus, scaffolding and utensils needful for performing the carpenter work in the best and most workmanlike manner, according to the drawings and specifications.

All the material to be of the best description. Should the contractor introduce any material different from the sort and quality herein described or meant to be implied, they shall be removed within twenty-four hours after notice to that effect from the superintendent, A. W. Wright.

The works are to be executed in the best, most substantial and workmanlike manner, according to the true intent and meaning of these particulars and the drawings referred to, which are intended to include everything requisite and necessary to the proper and entire finishing of the carpenter work, notwithstanding every item necessarily involved in the said work is not particularly mentioned; and all the work, when finished, to be delivered over in a perfect and undamaged state without exception. No part of the work to be underlet unless by written consent of A. W. Wright.

The contractor to be responsible for all violations of law caused by his obstruction of streets, sidewalks, etc., with his materials, and, at the completion of the work, shall remove all his rubbish and material from off the premises. The carpenter to do all necessary woodwork, cutting, etc., for other craftsmen on the building; to provide and set centers on which to turn arches.

The drawings and specifications are the property of the superintendent and must be returned to him on completion of the work. The contractor shall not make any alterations of the drawings. Should any error appear in them he shall refer to the superintendent for corrections. He must carry on his work at all times with the greatest reasonable rapidity under the direction and to the satisfaction of the superintendent.

### TIMBER.

All the material used in and throughout the building to be of the best common pine lumber, except as hereinafter specified. To be free from sap, shakes and other imperfections impairing its durability or strength. Well seasoned; sawed, square edges.

The studding in plastered partitions will be 2" X 4" - 16" centers. First floor joists the same buried in asphalt cement. All joists to have full and true bearing, with an inclination in the stalls of 2" towards the rear.

The carpenter shall make all boxes for the plumber for each hydrant or stop-cock, make all necessary watering and mixing troughs, sizes as shown on plans, of 3" dry pine and put together with white lead and rope centers in joints. He shall make all boxes necessary to be built in brick walls for the proper sliding bars.



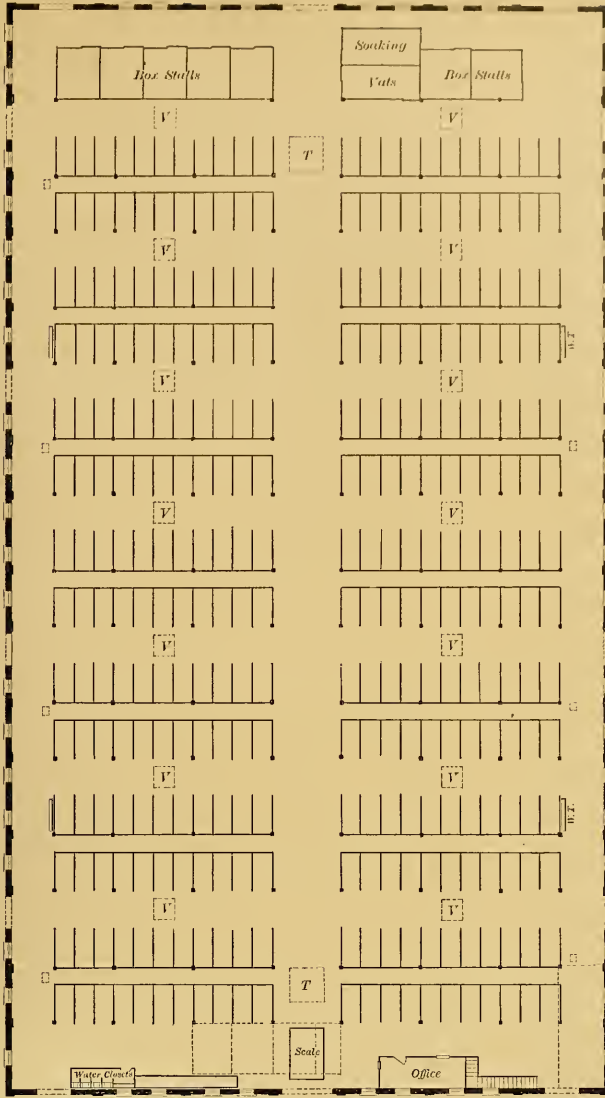

PLAN

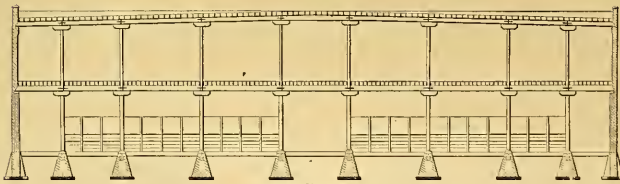
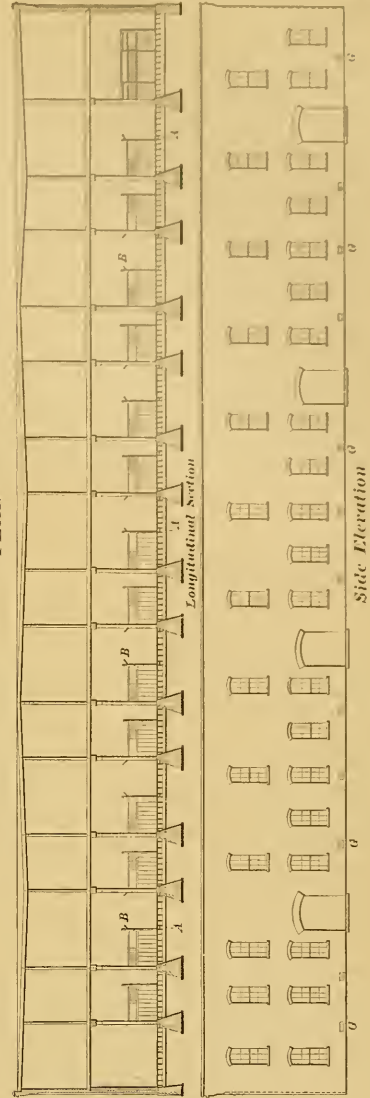

Cross Section

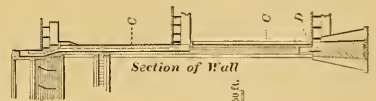

Section of Wall



End Elevation on Street

FIG. 60.

(To be continued.)

### Street Railways of California.

The Golden State boasts of ten or eleven cities so far advanced in social progress as to be well supplied with street railways.

In the City of San Francisco, there are thirteen street railway companies, operating altogether 127½ miles of single track. Four of them use the cable system only, aggregating 34½ miles of track. One company has five miles of cable road, and 4¼ miles operated by steam, *i. e.*, locomotives. One company has 7½ miles cable, and four miles horse railway. And one has five miles cable, one mile horse, and four miles steam railway. Four companies use horses only, and the aggregate length of their tracks is 62 miles; while two companies, one with 4.62 miles and one with 1½ mile of track, use locomotives only.

The Market Street Cable Railway Co., who operate five roads, have a bonded debt of \$3,000,000. The cost of their roads amounts to \$4,000,000; and they have a capital stock of \$5,000,000. Similar information concerning the other companies, and further interesting particulars concerning the street railways of this famous city, are admirably set forth in the following tabulated statement, for which we are indebted to the Mayor of San Francisco and his Secretary, and especially to Mr. A. S. Hallidie, President of the Cable Railway Company, San Francisco.

SAN FRANCISCO STREET RAILWAYS.

NAME.	Capital Stock.	SINGLE TRACK—MILES.			Cost.	CARS OPERATED.				Horses.	ANNUAL RESULTS.	
		Cable.	H'ise	Steam.		Cable.	Horse.	St'in.	Steam Motors.		Passengers Carried.	Dividend (Monthly)
Market Street .....	\$ 5,000,000	17.2	---	---	\$4,000,000	200	---	8	3	---	10,000,000	---
California Street .....	1,000,000	5	---	---	400,000	28	---	---	---	---	2,500,000	\$5,000
Clay Street .....	500,000	2	---	---	125,000	14	---	---	---	---	1,200,000	1,250
Geary Street .....	1,000,000	5	---	4.25	375,000	40	---	6	3	---	3,000,000	5,000
Sutter Street .....	1,000,000	7.2	4	---	540,000	80	30	---	---	180	3,500,000	---
Presidio & Ferries .....	1,000,000	5	1	4	450,000	30	4	4	4	22	2,000,000	2,500
Powell Street* .....	1,000,000	10	---	---	600,000	---	---	---	---	---	---	---
City .....	1,000,000	---	11	---	88,000	---	72½	---	---	280	2,500,000	---
Central .....	1,000,000	---	12	---	90,000	---	31½	---	---	290	2,000,000	---
Omnibus .....	1,000,000	---	18	---	144,000	---	60	---	---	390	3,000,000	---
N. Beach & Mission .....	1,000,000	---	16	---	128,000	---	61	---	---	420	4,000,000	---
Park and Ocean .....	---	---	---	4.62	---	---	---	16	7	---	3,000,000	---
Potrero & B. View .....	---	---	---	1.5	---	---	---	10	---	43	1,000,000	---
Totals .....	---	51.4	62	14.37	---	392	271	34	17	1,025	37,700,000	---

\* In course of construction. Will run by October.

† Mostly one-horse cars.

‡ Partly one-horse and partly two-horse cars.

The Market Street Cable Railway Company's system is the most extensive and elaborate in the city. The tracks are all built in superb and enduring style, and "are calculated to last all time." All the lines belonging to it are the sole property of the great railroad magnates, Messrs. Stanford, Huntington, Crocker and Hopkins, owners of the Central Pacific and Southern Pacific Railroads. The Market Street Cable Railway Company was granted its franchise, Valencia, McAllister, Hayes and Haight street Markets in September, 1879, but did not begin work until June, 1882. In July, 1882, the Haight street branch was begun and both were finished during the following year. The McAllister branch was built in 1885, and the Hay street branch began running in 1886. In connection with the Market street system are the steam-dummy road through the Market street cut, which has been running for years, and the Park and Ocean Railroad, the franchise for which was obtained in 1879 and renewed and amended in October, 1883.

"It is reported, but I do not vouch for the fact," says one who has favored us with very valuable information, "that the first line on Market street, continued on Valencia street cost, fully equipped, \$2,500,000. The company issued \$3,000,000 of 6 per cent. bonds, which were taken at once by the Bank of Nevada and others at 103. They are quoted to-day at 128. The city taxes each car for a license, \$15 per annum. The conveyance on all the old cable roads, such as the Clay Street road, the Sutter Street road, the

Geary Street road, consisted of two separate vehicles, coupled together, *viz.*, the dummy in front, the remaining car behind. The city charged \$15 for each of the two, or \$30 for the team.

"The Market Street company built their conveyances solid; that is, dummy and car on one truck, and by this means reduced their license, as for one car only, to \$15. Besides, this arrangement has been found far more convenient for passengers, and safer. The front or dummy part of the car is built with a step about a foot wide below the seat, the step being supported by iron columns.

"Yesterday (Sunday) I was returning on a Haight Street car from the park. I met an outgoing car at intervals of only a block, all along the route, and the people on the dummy (in addition to the crowded closed car) looked like a hive of bees just swarming. There were on every car, at least 14 men or youths standing on the step, on each side, or 28 standing and 20 sitting—in all, 48 passengers—on the dummy alone. The closed car, including the platform and centre aisle, contained, at least, 52 more. So that it is no exaggeration to say that every train carried 100 passengers. Of course there was a special inducement to attract such a crowd—a base-ball match at the park.

"I asked the leading agent of this company, a few days ago, what was the largest number of passengers his company

had carried in one day? He told me, confidentially, 70,000. This, of course, was an extraordinary day. But it shows (1st) the capacity of the road, and (2dly) what a car-traveling community our people are on a gala day."

Crossing San Francisco Bay, the next important city is Oakland, with its eight street railway companies; then East Oakland has one, while Alameda is united to Oakland by the Alameda, Oakland and Piedmont Railroad. The other street railways are the Oakland, Brooklyn and Fruit Vale (with offices at East Oakland), 2½ miles; the Oakland Cable Railway, 5 miles; Oakland Railroad, 10 miles; Fourth Street Railroad, 8 miles; Broadway and Piedmont Railroad, 3 miles; the Brooklyn and Fruit Vale Railroad, 2¼ miles; and the Berkley Villa Railroad, 2 miles.

Proceeding upwards, and crossing the Bay of San Pablo, South Vallejo is reached, which has a three-mile street railway.

Sacramento, the capital of the State, has but one street railway company, 5 miles, operating 12 one-horse and 12 two-horse cars.

Marysville is the most northerly city in the State with a street railway—the City Passenger Railway, recently opened.

Returning to the metropolis and port of entry, and proceeding southward, San José (the "Garden City"), has five street railways: Market Street and Willow Glen, 2 miles;



First and San Pedro Streets Railroad, 5 miles; San José and Santa Clara Railroad,  $8\frac{1}{2}$  miles; North Side Horse Railroad Company,  $2\frac{1}{4}$  miles; and the Willow Glen Railroad,  $7\frac{1}{2}$  miles.

No other street railway centre is found until Santa Barbara is reached. The Santa Barbara Street Railroad Company has five miles of track,  $3' 6''$  gauge, but only 3 cars are running, with twelve mules.

Los Angeles, in the southern portion of California, has pushed itself forward very prominently by taking the lead in applying electricity to propel street cars. As observed in the STREET RAILWAY GAZETTE for February, the advent of 1887 was signalized by the running of electric trains on Pico street, and Los Angeles is the first city west of the Rocky Mountains to adopt the electric railway means of inter-mural traffic.

The Temple Street Cable Railway Company, Los Angeles, has a capital of \$100,000. Length of road,  $15\frac{1}{2}$  mile (single track); cost, \$90,000. They have four cars running.

The Main Street and Agricultural Park Railroad Company, Los Angeles, have \$100,000 capital. They have three miles of double track, and three miles single (which will soon be double tracked), with 16 lbs. steel T rail; gauge,  $3' 6''$ . The line was opened for business in 1874. They have now 16 one-horse cars and 80 horses, the fare being 5 cents. The number of shareholders is twenty; the annual meeting is held in July. The present officials are: W. J. Brodrick, President; A. C. Taylor, Secretary; and E. M. Lanicke, Superintendent.

The other lines in Los Angeles are: The Second Street Cable Railroad Company,  $1\frac{1}{2}$  mile, with six grip cars and one passenger car attached to each. The Central Railroad Company operates 7 miles; the City and Central Street Railway Company,  $4\frac{3}{4}$  miles, part of which is cable, using three grip cars, the rest being operated by 171 horses. The Los Angeles and Aliso Avenue Street Railway Company, the Boyle Heights Railroad Company, and the San Fernando and Sixth Streets Railroad Company aggregate  $15\frac{1}{2}$  miles of track.

Anaheim, a few miles south of Los Angeles, has several lines of street railways in progress.

The most southerly city in the Golden State with a street railway is San Diego. A motor line is operated between San Diego and National City, by the San Diego Land and Town Company, averaging 2,000 passengers daily. The Henry Electric Light Company, of Kansas City, Mo., have undertaken to equip a suburban electric railway twenty miles long.

The San Diego Street Car Company (comprising nine shareholders) have seven miles of track in operation, and five miles or more extensions are intended. It is single track, with T rails. 16 lbs. and 20 lbs. to the yard; gauge,  $4' 8\frac{1}{2}''$ ; cost of construction and equipment, \$40,000, opened for business July, 1886; fare, 5 cents. They run 12 two-horse cars. Capital stock, \$100,000. Annual meeting is held on fourth Monday in January. Officers: H. L. Story, President; M. Santee, Vice President; C. R. Williams, Superintendent; R. A. Thomas, Treasurer; H. W. Mallett, Secretary.

The Coronado Beach Company (which comprises five shareholders) operate  $1\frac{1}{2}$  miles, and 3 miles extensions are contemplated. The line is single track, T rail, 20 lbs.; gauge,  $4' 8\frac{1}{2}''$ ; operated with steam motors; cost of construction and equipment, \$18,000; opened for business July, 1886; fare, 10 cents; capital stock, \$24,000. The annual meeting is held the fourth Monday in February. Officers: H. L. Story, President; J. Grundike, Vice President; O. S. Hubbell, Treasurer and Secretary.

Those who have furnished information about their lines have rendered valuable service to those interested in street railways everywhere, inasmuch as reliable information is greatly desired. Many, however, refuse to say anything about their companies. In New York, Pennsylvania and Massachusetts the street railway companies are required by law to furnish adequate returns regularly. California has not reached that state of progress yet. Nearly the end of two decades have been reached since the "new" constitu-

tion came into effect, and another is much needed—more new—to secure statistical returns.

Before 1870, when the new constitution went into effect, privileges to build street car lines were granted by the State Legislature, but after that these special statutes were transferred to the franchise book of the supervisors and the municipal board became the sole granting power.

In San Francisco, twenty seven years ago, a steam car line was run out Market and Valencia streets to the Mission, and it was about the same time that the Omnibus Railroad Company commenced to break ground. This line was in running order in 1862, and that year work on the North Beach and Mission road was commenced. This was completed in 1863, by which date also the Central car line was completed to Lone Mountain. The City Railroad Company was started next, then came the Sutter street road in 1865, and the Bay View and Potrero in 1866, while in 1867 the steam cars on Market street were discontinued and horse cars substituted. The Sutter street road was extended in 1869, and again from Polk street to Lone Mountain in 1870. It would be safe to say that not one of these roads runs now over exactly the route for which its franchise was asked, while many of them, notably the Central Road, had projects to its credit, which, as a supervisor recently said, would carry it all over the city.

### Moulton's Elevated Railway and Car Trucks.

There are now on exhibition at the State House, Boston, Mass., some beautifully constructed working models of an elevated railway and car trucks, the invention of David Moulton. A patent was granted February 10, 1885.

The plan is claimed to be a practicable one. Cars of the ordinary form can be run upon a narrow, permanent way, consisting of only a single line of posts and girders. The objections to the ordinary form of elevated railway, that darkens the street by its peculiarity of structure, are claimed to be avoided.

The models referred to show two forms of construction. One shows the permanent way to consist of a single line of girders, supported on columns which are continuous to the upper member of the girder, thus, it is said, giving great stiffness to the structure. Bolted to the sides of the girders are stringers, that carry the rails, which in this form have a gauge of thirty-four inches. The upper and lower members of the girders are plated with steel on both sides, and horizontal friction-wheels are fitted in the trucks opposite these plates, so as to bear against them in case of any lateral motion. These friction-wheels may, if necessary, be further utilized as gripping wheels in combination with brakes.

The inventor claims that strength and safety are secured by this system. The weight is borne squarely upon upright wheels, securing simplicity and strength in the working parts of both engine and cars, while the construction is such that it is absolutely impossible for the cars to leave the track through the breaking of wheels or rails.

A second form of construction shows the gauge widened and the lower friction-wheels are omitted. This somewhat simplifies the construction of both permanent way and rolling stock, and at the same time allows the latter, if necessary, to run from the elevated track upon an ordinary surface railway on reaching the outskirts of a city.

In both forms here described, the wheels on opposite sides of the tracks are mounted on short axles independent of each other, a point of great importance, as by this means the cars are able to pass very short curves without the increased resistance caused by having both wheels on one axle, as in the ordinary form of construction. This part of the invention may be applied with advantage to the cars of ordinary horse and other railways.

For motive power, steam, electricity or cables can be easily and effectively applied.

THE Van Depoels Electric Manufacturing Company, whose electric railway at Scranton, Pa., has attracted great attention, and inspired other cities to seek the "coming power" for propelling street cars, are full of orders.

# The Street Railway Gazette.

Annual Subscription (Including Postage).		Per Copy.
United States, Canada.....	\$2.00.....	20c.
Great Britain, Ireland, India, Australasia.....	9s. 8d.....	11d.
Germany.....	9mk. 75 pf.....	89pf.
France, Belgium, Switzerland.....	11fr. 95c.....	Fr 1.10.
Spain.....	11rs. 95c.....	Ps 1.10.
Austria, Holland.....	5fl. 74c.....	53c.
Italy.....	12 lire.....	1 1/4 lira.
Venezuela.....	12 bolivars.....	1 1/2 bol.
Mexico.....	\$3.96.....	30c.
Add. Subsc. in Argentine Republic, 2 1/2 pesos; Brazil, 4 milreis; Turkey, 54 piasters.		

Registered Cable Address=TRAM, CHICAGO.

## PUBLISHERS:

THE WRIGHT-MONROE COMPANY.

Augustine W. Wright, - - - - - President.  
E. V. Cavell, - - - - - Secretary.  
S. L. K. Monroe, - - - - - Treasurer.

## GENERAL OFFICES:

CHICAGO, - - - - - NEW YORK, - - - - - BOSTON.

### CHICAGO:

9 LAKESIDE BUILDING.

F. G. Monroe, - - - - - General Manager.  
William Hughes, - - - - - Editor.  
Edward J. Lawless, - - - - - Associate Editor.

### NEW YORK:

181 BROADWAY.

Henry C. Lockwood, - - - - - Resident Editor and Manager.

### BOSTON:

19 TREMONT ROW.

T. P. Pemberton, - - - - - Resident Editor and Manager.

## EUROPEAN OFFICE:

LONDON: W. S. Graft Baker, Jr., Resident Manager.

## BRANCH OFFICES:

ATLANTA, Ga.: Chamber of Commerce Bldg., Wm. Minnigerode, Mng'r.  
SAN FRANCISCO, Cal.; 1222 Bush St.,—G. W. Fairchild, Manager.

## CANADIAN AGENCY:

TORONTO: 53 Magill Street,—Thomas Henry, Manager.

MR. W. S. GRAFT BAKER, JR., our newly appointed European representative, boarded the Arizona (Guion Line) April 19, at New York, accompanied by Col. H. C. Lockwood (the GAZETTE'S representative at New York) and Mr. E. V. Cavell (secretary of the Wright-Monroe Co.), together with a party of friends from Baltimore, and a cablegram of the 28th announced his safe arrival in Liverpool.

MR. E. E. RUSSELL TRATMAN, C. E., of 144 Remsen Street, Brooklyn, N. Y., who is interested in street railroad matters, asks us to state that he will be very much obliged if street railroad associations and companies, or their secretaries or superintendents, will send him copies of their reports, or other public information, more especially with regard to lines employing steam traction. Mr. Tratman is engaged in collecting all available information relating to street railroad construction, operation, etc., and any drawings, reports, or other matter will be fully appreciated by him.

LOUISVILLE, Ky., rejoices greatly over the progress of the city's street railways in general, and over the completion of the Daisy line as far as the Base-Ball Park in particular. "This will be grand news for the lovers of this sport who desire speedy and dustless transportation. \* \* \* All along the bridge lines there are destined to go up a large number of residences, and indeed a continuous town from one end of the city to the other. Those who have not kept pace with this great work will be surprised to see how well and how fast this improvement has been made. It is graded for a double track and the heaviest rails have been laid, and first-class time will be made."

CHARLES DICKENS did not write the article on American Street Railroads published in *All the Year Round* of April 6, 1861, and reproduced in our last issue. We thank Mr. Charles Dickens, Jr. (London,) for informing us that it was written by the late Mr. George Walter Thornbury.

CONTENTION is not yet ended with the Arcade Railway Company, New York. Since our last issue a new suit against it has been commenced, by abutting property owners, in the Supreme Court. They allege that the proposed excavation would endanger many of the buildings on Broadway by loosening the foundations, and that the damage otherwise caused to water, sewer, gas connections, etc., would be irreparable.

RUSSIA is likely to have an electric railway ere long. According to the Moscow *Technik* a project has been set on foot by some Belgian capitalists for the construction of a short railway in Russia to be worked by electricity, and to connect Varsovie, Wilanow, Mokotow and Czerniakow. The necessary concessions have already been applied for; if they are granted this will be the first introduction of electric railways in the Russian Empire.

MILWAUKEE'S late city council expired April 19th, and its last act was to receive a new street railway ordinance, particulars of which are recorded in another part of this issue. That the "old council" died bravely is evidenced by the fact that, as soon as the street railway franchise had been properly introduced, "President Baumgertner then declared the council adjourned without date, bringing down his gavel with a sharp rap that startled all the members."

MR. JOAB MULVANE, president of the Topeka City Railway Company, says they will "boom" Topeka "as she has never been boomed before," if the inhabitants will encourage their street railway, and they intend to make Garfield Park one of the most beautiful spots in the entire west, to induce the people to ride in the cars to go there. They intend "to use some improved motor in a short time."

A MOTOR has been ordered from New York, it is said, for the Princess Motor Line Co., Wichita, Kan., who intend to have their line opened on the Fourth of July. "It is not a mule motor, either," says one of the directors; "we would not disgrace the south part of the city, or any portion, by offering to use a three-legged Mexican mule. This city is getting big enough, in fact, is big enough, to put on style, and companies can afford to operate a respectable line."

MR. C. B. FAIRCHILD, manager of the Twin Cable Ry. Co., of New York, is in Chicago, with a full working model of their system exhibited at the barns of the Chicago City Ry., 39th and State streets, and he would be pleased to have all parties interested in cable railway construction call and examine into the working detail of the system. Mr. Fairchild will remain in Chicago but a few days, as he is en route for the West, and intends visiting Omaha and Lincoln, Nebraska, and other prominent western points before returning to the East.

It is very seldom, fortunately, that street railway companies fall in collision with city authorities; but it sometimes happens. Sometime ago we noticed such an event in Massachusetts; now we have to record a deplorable incident at Houston, Texas. Mayor Smith notified the Houston Street Railway Company, April 16, to remove their track on Congress street, in order to permit the paving of that thoroughfare. The company refused to take up the track. Mayor Smith notified Manager McGregor that unless the track was taken up by 1 o'clock, April 18, he would have it removed by the street force. At 1 o'clock the work of tearing up the track under the direction of the city marshal was begun. Manager McGregor then served a writ of injunction upon the mayor, restraining him from further interference with the company's property until the writ could be heard.



ACCIDENTS occur now and then even on street railways; but the street car officials are, as a rule, very careful, and the faults of mishaps are seldom attached to them. Mr. D. G. Hamilton, a real estate owner, and a director of the Chicago City Railway Company, was seriously injured, April 26, while on his way to the directors' meeting, through the carelessness of the driver of his carriage, which was demolished by a grip-car while crossing Cottage Grove avenue. Mr. Hamilton was thrown to the ground, and rendered insensible, and his skull was fractured.

JUDGE MCGILL, April 11, affirmed the decision of the court below in the Jersey City house-removing case. The Jersey City and Bergen Railroad Co. sued J. Costigan and T. Egan for removing a house across their track whereby traffic on the street railway was delayed several hours. Although the aldermen of the city had granted permission to remove the house, the verdict went against the defendants last July, and now the appeal judge has affirmed the judgment, holding that both owner and remover are responsible, and that the aldermen have no right to grant a privilege to private parties involving a public nuisance. A similar nuisance recently occurred in Chicago, blocking the Van Buren street cars several hours. This decision removes the doubt in which the question has hitherto remained; and now the illegality of blocking a street railway, by the removal of a house, is made quite clear.

ST. JOSEPH, MO., will see three cable railways in process of construction this summer, probably. While nothing has yet been made known as to the exact routes, there is a great deal of surmise. Two of the railways will be built and operated by foreign capital, and the third one by St. Joseph money. Mr. John S. Brittain, one of the ten gentlemen of St. Joseph, is receiving signatures readily in favor of the right-of-way on Jule street to the eastern city limits. The other cable project is headed by Kansas City capital. A gentleman from that city has been in St. Joseph several days talking up the scheme. The third project is for a cable from the union depot out on Mitchell avenue to the city limits.

There is a feeling among the gentlemen interested to build the St. Joseph lines without curves or turns.

SINCE the publication, in the April GAZETTE, of the views of O. B. POTTER, favorable to an elevated railway in Broadway, New York, others have raised a howl against it—considering that such a scheme would amount to a national calamity. The weight of public opinion, however, is in favor of the project. Mr. Edward Schell, president of the Manhattan Savings Institute says: "There is an absolute need for increased facilities of rapid transit between the upper and lower parts of Manhattan Island. The elevated roads now in existence are overcrowded and the city is growing northward rapidly. Broadway is in the natural line of travel, and it should have more rapid transit facilities. The present surface road was opposed, but it has proved a benefit to Broadway. An elevated road would be a still greater benefit. These roads would make Broadway a great thoroughfare. An elevated road, so far from injuring the street, would, in my opinion, help it, and I favor it."

MERIDIAN, MISS., is the best city in the State," says J. S. E., Jr., in the New Orleans *Picayune*, and "her chances for becoming a grand city are better than [those of] any place in the country." And, after enumerating the special features which are to contribute to Meridian's coming grandeur, this special correspondent proceeds to say that "eleven thousand people live here, and every man is making a living and is honored by the people he lives among. A very happy state of affairs exists. The city government is in the hands of the city's friends. Her people are nineteenth century people. They are alive and progressive. The city plainly indicates that. She has four miles of street car track, running from the depots to the Queen and Crescent Railroad shops at West End.

MINNEAPOLIS is anxious to have its cable street railways in operation as soon as possible. And Mr. Thomas Lowry is envied by some for the splendid bargain he is supposed to have made by the sale of street railways reported in the ST. RV. GAZETTE. Gen. Bishop, of the transportation committee, to whom had been referred the matter of the new cable lines of the street railway company, said that he had received assurances from the company that the lines would be built and ready for use by November, 1888. Capt. Berkey thought that such corporations as the gas and street railway companies enjoyed too great power. Thomas Cochran said that by virtue of the franchise granted him by the city, Mr. Lowry had been able to make \$1,000,000 on the sale of his street railway stock. Delay in the matter of cable lines should not longer be put up with.

Mr. Horn believed that the rights of the city were sufficiently protected. He thought that the cable line was likely to cost \$1,000,000.

THE Court of Appeals, at Albany, N. Y., delivered an opinion, recently, "on the motion for re-argument in the matter of the New York Cable Railway Company, which was denied, with costs." The most curious incident connected therewith is that a director of the company, at New York city, could not understand whether the decision was favorable to the company or the reverse. He said, "It is difficult to determine from here what the bearing of the decision really is; it may be a substantial victory. You remember that when the Court of Appeals made its former decision in our case, it was at first heralded as a defeat. An examination of the decision showed that the company had gained all the law points for which it had been contending." Chas. P. Shaw, the counsel for the company, went forthwith to Albany to examine the "opinion," which is as follows:—"The order made by this court affirming the order of the general term, denying the application of the Cable Company will be no obstacle to a rehearing of the matter at the general term on a new state of facts, or to a new application based on new facts, and on such new hearing it will be open to the Supreme Court to exercise discretionary power over the whole matter or to pass, as it did in the first instance, only on questions of law." The court does not call in question the legality of the Manhattan Railway Company because, it declares, that issue was barely incidentally considered by the court when it decided the cases of the elevated railway companies of New York.

"HOPE you will excuse my troubling you with what may appear to you as the writings of Jules Verne—but the predictions of that writer may yet be realized," says a correspondent from St. Joseph, Mo., under date of April 11th. He goes on to say: "We are at the present time in a state of 'boom' of the first water in this city—every one has got the fever. We have three street car lines, and a cable line in prospect. The managers of the Union line have been East, to see the success of the electric motor, and have come back full of it—quite a success. Well, our city is full of steep grades. The Frederick avenue line has been bought by a syndicate of wealthy men, and they say they will await further developments, as regards power. They are relaying new 60 lbs. steel rails, and ordering new cars; and there are prospects of still further extensions of several miles. Now, what I want to get at is, Can't you put some party on that can supply a steam motor of some kind that will run successfully here?" What our correspondent really wants does not exactly appear. But he seems to need something better than any motor hitherto known, and declares that "it is a bonanza if the right thing would turn up." He adds that "there is a talk of adopting something of that kind in place of the cable, at Kansas City, and they claim 150,000 inhabitants." And he says the population of St. Joseph is 65,000. We would readily "rustle this up, while things are warm," as he puts it, if any more could be done than publishing the information contained in the STREET RAILWAY GAZETTE; and when the "right thing" is developed, we shall only be too glad to make it as widely known as possible.

### Centre-Bearing and other Rails.

Like Sinbad the sailor, the street railway men of this country have ever with them "an old man of the mountain," in the question as to the best form of rail for general use. This question has recently been brought prominently to the front in New York City, by the expressed determination of Mayor Hewitt to add to his other reforms, the solution of this problem. Should he succeed in solving this question—and so bring peace and rest to the puzzled brain of the street railway man—he could count upon a lavish testimonial of affection from their gratitude that would put, —well say, the "Broadway Boodle" to the blush. There has been an amount of ignorance and absurdity infused into the many discussions of this question, which periodically occur, that would do justice to the court of old Wouter Van Twiller, erstwhile of New York, or as then known, the New Netherlands.

Now that it has the sanction of Mayor Hewitt's known views, every penny-a-liner finds it good matter for waste space in the "Sunday edition." Like little Jack Horner he "puts in his thumb, and pulls out a plum, and says what a wise boy am I." Naturally, the street railway interest becomes "the ogre" and the public "the long suffering victim."

Any discussion based upon this assumption, bears upon its face the stamp of the amateur. As a matter of fact, no point is more certain than that the street railway interest and that of the public are in this respect identical. We might point out that the public spoken of exists in a double capacity—those who use the tracks by riding in the street car, and those who use the tracks by driving on or over them in the street vehicle. We might also point out the fact that though a larger number of street vehicles exist, than street cars, if considered "per capita," the public who avail themselves of the use of the street car far outnumber the other branch of the public, and that, therefore, their comfort is the first consideration. But while this is true, the mutual interest of street railroad and public is interwoven with stronger bonds than this.

A good adjoining road-bed is a support to the track, almost as indispensable as a good foundation. A poor adjoining road-bed means a track costly to keep to gauge, and a repair sheet that is not comfortable. When the sheet vehicle breaks down the street railway man generally foots the bill. How many instances can be cited wherein the street railway man improves the adjoining pavement at his own cost in preference to neglecting it, when the nature of the street traffic or the surrounding road-bed renders such an investment of any use?

Mayor Hewitt has spoken of the old form of flush groove rail upon which he improved (in the street railway interest according to his views) by devising what is now known as the centre-bearing section. He tells us that this flush groove rail was long used—used in fact until the street railway man *had* to devise something else, and he gives as the reason the excessive wear of both rail and pavement. We will add to this that a groove rail, similar to this in principle, is almost the only rail now used in England, in France, Belgium and very largely in Germany, and we will further add that under certain circumstances it is perhaps the best rail that can be used. What are these circumstances? *Perfect and well kept up road-bed construction*—a perfectly level road-bed, and a perfectly even and smooth rail (the flush groove rail, if you please) inserted in such road-bed with everything level and non obstructive.

Street vehicles have a clean sweep, and they tend no more to run on the rail than on any other part of the street. So long as both maintain the same level, so long is this the case. But let the rail or the road-bed part company, be it ever so little, and what happens? It happens that the street vehicle no longer chooses its path, but finds its path chosen for it, and be it remembered, that a very minute projection will determine that path. It happens further, that this "determination of travel," so to speak, concentrated at what, in its very nature, is the point of weakness in the assumed composite structure, soon creates ruts and grooves and leaves the rails exposed and obstructive.

Such has been the history of the early use of the flush groove rail in New York. Such has been the history of a very recent experiment with the flush groove rail in Baltimore, and such will be the history of the flush groove rail wherever used, until the American method of road-bed construction is re-modeled.

If Mayor Hewitt is in earnest in desiring this form of rail let him evince his earnestness by preparing for its use in the proper manner. Let him build his road-bed as the Romans did, and as the English and other European nations are now doing, and he will then find the street railway men as anxious as himself for the flush-groove rail. This is why all Europe uses it and why all America *does not* use it.

As an alternative, and while we await this "Arcadia," the much abused centre-bearing is the best and most thoroughly common-sense rail that can be adopted. There exists an exposure (in the head) to determine the line of street travel, it is true, but there also exists a steel road-bed to keep the travel from cutting down too deeply into the surrounding pavement, in the shape of the side tram; and unlike the side-bearing rail this steel road-bed or tram exists on both sides of the head. It may be justly urged that the streets become rutted and grooved, and in a city like New York, it is true, much as they become so—with the centre-bearing—they would become more so with the flush-groove rail with the same road-bed construction. So clearly has this been proved that in the centre and western parts of this country the centre-bearing rail is rapidly edging out the side-bearing, and its strongest advocates are the city engineers and street commissioners.

### The American Street-Railway Association.

The fifth volume of the proceedings of the American Street-Railway Association has been issued. It contains a verbatim report of the fifth annual meeting of the Association, commonly called the Cincinnati Convention, held at the Burnet House, in the "Queen City of the West," October 20 and 21, 1886.

It is interesting to notice, retrospectively, that the first conventional meeting of street-railway delegates ever held and which prevented\* the formation of the above-named Association, was held in Cincinnati, Nov. 22, 1882, when the Ohio State Tramway Association was formed. The American Street-Railway Association was organized three weeks later (Dec. 12 and 13, 1882), at Boston, Mass. And the organization of the Street-Railway Association of the State of New York became *un fait accompli* thirteen months later than that of the Tramway Association of the "Buckeye State," viz., December 19 and 20, 1883.

The "origin" of the American Street-Railway Association is comprised in the following circular letter, which "was sent to all the Street-Railway companies throughout the United States and Canada:"

"LOUISVILLE, KY., November 8, 1882.

"DEAR SIR: Permit me to call your attention to a matter which has for some time been considered by a number of Street-Railroad men, viz.: The formation of an Association based upon well-established principles governing similar organizations, the object of which shall be the promotion and advancement of knowledge, scientific and practical, in all matters relating to the construction, equipment and management of street railways; the establishment and maintenance of a spirit of fraternity among the members of the Association, by social intercourse and friendly interchange of information and ideas, to the end that the best service may be obtained at the least possible cost."

"With this object in view, I have been requested by a number of Street-Railway officials, both in the East and West, to issue this circular, and urge that your company send a representative to a Convention to be held in the city of Boston, on the 12th day of December, 1882, for the purpose of organizing and adopting a Constitution for the government of such an Association."

"It is expected that most of the prominent Street Railway companies in the United States will be represented. Will you be kind enough to notify Mr. J. E. Rugg, Supt. Highland Street Railway Co., Boston, Mass., at once whether your Company will send delegates, in order that adequate accommodations for the Convention may be made in advance?"

\* *Prevented*, which had become obsolete in its etymological and more comprehensive meaning, is coming into use again; and in this connection the term means much more than *precluded*.



As soon as replies are received arrangements will be made, and you will be notified of the location and the hour the Convention will meet.

Very respectfully,  
H. H. LITTELL,  
Supt. Louisville City Railway Co."

In due course, Mr. Rugg "received assurance from nearly all the Street Railway companies in the United States and Canada that they will be represented in the Convention, and that they are in full sympathy with the movement." In calling to order the first Convention (held at Young's Hotel, Boston), Mr. Littell observed that "nearly all branches of industry and trade have their organizations, and it has long been to me a matter of surprise that the many street railway companies have not organized an Association for the mutual benefit of all parties interested in this mode of traffic. With this motive in view, after conferring and corresponding with a number of street railroad presidents and superintendents, I took the liberty of issuing the circular, calling upon every road to send a delegate to this meeting." The first Convention was fortunate in selecting as Chairman the Hon. Moody Merrill, then president of the Highland Street Railway Company (which was amalgamated with the Middlesex Street Railway Company, last summer, to form the Boston Consolidated Street Railway Company); and Mr. Merrill's inaugural address affords an admirable point of observation in the history of street railways in general, and of the American Street-Railway Association in particular. He said:

#### STATISTICAL SUMMARY OF STREET RAILWAYS IN 1882.

"You have come here from all parts of the country for the purpose of forming a National Street Railway Association. Some one may ask what interest in common affecting the street railways of the country (corporations local in their character) can have, that would seem to call for an organization for their protection. I would say that, probably, our Association is not to be formed so much to *protect* our interests as to *promote* them. The street railways of this country have grown so rapidly during the past ten years, and are still growing with such rapidity, that an Association of this character seems highly desirable. There are now organized and doing business in this country and Canada four hundred and fifteen street railways. These companies employ an army of about 35,000 men. They run 18,000 cars, which, with the horses attached, would make a solid line of cars reaching from Boston to Albany. More than 100,000 horses are in daily use, and calculating that the average life of a horse in street railway service is four years, it makes the consumption of horses 25,000 per year, a fact of much importance to the farmers of the country, east, west, north and south. To feed this vast number of horses requires annually 150,000 tons of hay and 11,000,000 bushels of grain.

"These companies own and operate over 3,000 miles of track—nearly enough to span the country from Boston to San Francisco. The whole number of passengers carried annually is over 1,212,400,000, or a number nearly equal to the entire population of the globe. The amount of capital invested in these railways exceeds \$150,000,000, with absolutely no security but the faithful and satisfactory service rendered the traveling public by the companies themselves. The object of this contemplated Association should be the advancement of scientific and practical knowledge in the construction, equipment and management of street railways. The public is continually requiring of us a better and higher order of service; for while, ten years ago, the street cars were run almost exclusively for the accommodation of the poorer and middle classes, now the wealthier classes are our most liberal patrons. A few years ago, the cab and the hack were the only vehicles called in requisition for the lecture, the concert and the theatre, but now the street car is almost exclusively patronized for that purpose. Cars can be seen going to and from these places of entertainment filled with ladies robed in silks, velvets and ermine, and adorned with costly jewels of emeralds, rubies and diamonds. This change in the character of our patronage demands continual improvement in our service. It would seem to be important that there be established a central office or bureau, where the improvements in the service of the different companies could be reported, and where all reports of the decisions of the courts in patent cases and damage suits affecting street railways should be kept, so that any member of the Association could have access to them.

"There should also be kept at this office correct information concerning the state of the horse, hay and grain markets in the different sections of the country, so that reliable information concerning all these vital interests can be obtained at all times. Other interests of equal or of greater importance than these I have mentioned will, undoubtedly, occur to you. Let your deliberations be thoughtful and harmonious, and your action such as to command the support and hearty co-operation of every street railway in the land."

The United States were well represented at the Boston Convention; and Canada had a couple of representatives from Montreal. Mr. W. H. Hazzard (Brooklyn), who moved the resolution to form the Association, suggested that it be called "The Street-Railway Association of the

United States and the Dominion of Canada;" but the special committee that subsequently drew up the Constitution and By-Laws named it the American Street-Railway Association, in reference to which a discussion was opened by the Hon. Geo. B. Kerper, president of the Mt. Adams and Eden Park Inclined Railway Co., who represented his own company, as well as the Union Pass. R. R. Co., of Baltimore, and he was also (be it observed) one of the six representatives of "the State organization of Ohio." Mr. Kerper thought the word "American" might be objectionable to the Canadian delegates; and Mr. T. H. Kobillard, of Montreal, suggested that "North American" be substituted; but Mr. John Crawford, of Montreal, understood that "America" included the Canadas and South America—in fact, the whole American continent. And ultimately it was so decided, and unanimously adopted.

The honor of "first permanent presiding officer" of the Association was cordially conferred upon the convener of the organizing Convention, Mr. H. H. Littell, of Louisville, Ky. Mr. Wm. J. Richardson, of Brooklyn (whose portrait and biographical sketch appeared in the STREET RAILWAY GAZETTE of January last), was unanimously elected Secretary; which position he has been induced to hold continuously. Special committees were forthwith appointed to prepare papers to be read at the "next regular meeting" (which was held at the Grand Pacific Hotel, Chicago, Ill., October 9 and 10, 1883), on "Track Construction," "Propelling Power," "Building," "Labor and Wages," "Collection of Fares," "Removing Snow and Ice," "Horse Shoeing," and "Heating and Lighting." Interesting discussions thereon were held in due course.

The "object" of the American Street-Railway Association is "the acquisition of experimental, statistical and scientific knowledge relating to the construction, equipment and operation of street railways, and the diffusion of this knowledge among the members of this Association, with the view of increasing the accommodation of passengers, improving the service and reducing its cost; the establishment and maintenance of a spirit of fraternity among the members of the Association by social intercourse, and the encouragement of cordial and friendly relations between the roads and the public."

"The members of this Association shall consist of American Street Railway Companies, or lessees, or individual owners of street railways, and each member shall be entitled to one vote by a delegation presenting proper credentials."

"Members shall pay an initiation fee of twenty-five dollars, and annual dues of fifteen dollars, payable in advance. The Executive Committee shall have no power to expend, for any purpose whatever, an amount exceeding that received, as hereinbefore provided for. It shall be the duty of members to make such returns to the Secretary, as shall be required by the Executive Committee. No member whose annual payment shall be in arrears shall be entitled to vote."

The Association counted 63 members January 1, 1884. At the Chicago Convention (the previous October) Mr. William H. Hazzard, president of the Brooklyn City Railroad Company, was elected President for 1883-4. "A uniform system of accounts," ventilation of cars, electric railways and the cable system, and taxation and license were the additional subjects discussed at the New York Convention, held at the Fifth Avenue Hotel, New York City, October 15, 16 and 17, 1884.

Mr. Calvin A. Richards, President of the Metropolitan Railroad Company, Boston, was the next President. Some of the previously stated subjects afforded ample material for edifying discussion at the fourth annual meeting, which was held at the Southern Hotel, St. Louis, Mo., October 21, 22 and 23, 1885. Mr. Julius S. Walsh, president of the Citizens' Railway Co. of that city, was elected President of the Association for the year 1885-6.

A full report of the Cincinnati meeting, last October, was given in the November GAZETTE. The official report now before us, contains further interesting details. The additional subjects discussed at the last meeting were, "Cause, prevention and settlement of accidents," and "San-

itary condition of street cars." Much additional information was, of course, adduced concerning the previously discussed subjects of cable propulsion and electricity.

The total receipts last year amounted to \$3,244.70; and the expenditure, \$2,226.63.

Mr. Thomas W. Ackley, president of the 13th and 15th St. Pass. Ry. Co., Philadelphia, is the President of the Association this year. The office of the Secretary and Treasurer (Mr. Wm. J. Richardson) is at the corner of Atlantic and Third avenues, Brooklyn, N. Y. The number of members, at present (May 2, 1887), is 153.

The next Convention is to be opened the third Wednesday in October (19th) at Philadelphia. Specially prepared papers will be read on the cable, electric and other means propulsion; fire insurance, etc.

### The Horse Railways of Berlin.

Since writing the chapter on British Tramways, wherein it was computed that 84,504,875 passengers were carried by the horse railways of the German capital last year, the Business Report for 1886 of the *Grosse Berliner Pferde-Eisenbahn Actien-Gesellschaft* has come to hand, from which it appears that the number was 85,500,000—being an increase of 8,150,000 over the 77,350,000 carried in 1885; *i. e.*, an increase of more than 10%. The receipts from this source have risen from \$2,256,186 the previous year, to \$2,490,949—an increase of \$234,763, or 10½%.

During the year about 48,273 miles of new track were laid, making a total of 131,674 miles of track now operated. This increase of mileage exceeds the increase during any other single year, by 4,313.46 metres, only 32,292 metres (20+ miles) having been laid in 1875 (eleven years ago), and two years after the opening of the system) which was hitherto the most active year in this respect. At the close of 1885 the company owned 612 cars, and during last year the number was increased to 697, by the purchase of 85 new cars. The rolling stock at this time comprises 169 two-horse cars, "double-decked"; 335 two-horse cars, "single-decked," and 193 one-horse cars.

On the 1st of January, 1886, the company owned 3,111 horses, and purchased during the year 957 additional horses, making a total of 4,068.

The gross receipts for 1886 amounted to \$2,509,910; expenditure, \$1,330,369, leaving a balance of \$1,179,541. Thus the year's profits reached 53%; and in 1885 it was 52.26%. After deducting the necessary sums for the sinking fund, renewal fund, etc., there remained \$545,224.80 to be distributed in dividends to the shareholders. The capital stock being \$4,104,000 this yielded a dividend of 11¼%.

The report is admirably minute, comprehensive, and thorough (in fact, thoroughly German), and shows a healthy financial state and steady progress.

### Personal.

MR. M. I. MASSON, manager of the Slawson Fare Box, recently favored our New York office with a friendly call.

GEN. A. K. STILES, of the Van Depoele Electric Co., of Chicago, was recently at the Astor House, New York.

MR. CHAS. D. HAINES (Haines Bros.) of New York, seems to be a traveler; we ran across him in Philadelphia, went to sleep and found ourselves talking with him in Ithaca, then broke bread a few hours with him in Gotham.

Judge T. J. Latham, president of the Memphis, Greenwood and Prospect R. R. Co., is one of the most progressive and wealthy men of Memphis, and is also president of the Water Works Company.

MR. J. A. VanHoose, vice-president of the same company, will probably be remembered as president of the Birmingham and Pratt Mines Street Railway Co., of Birmingham, Ala. The latter Company has recently purchased the Birmingham Street Railway Company, and now, under the name of The Birmingham Union Railway Co., own all the horse-car lines in that city. Mr. VanHoose is President and General Manager of that Company, and controls 3-7 of its capital stock of \$1,000,000.00 (one million).

### POINTERS.

#### ALABAMA.

*Birmingham.* The Western Valley St. Ry. Co., reported in the February GAZETTE, has increased its capital stock to \$50,000, and will build over four miles of track.

*Greenwich.* The Greenwich St. Ry. Co. has been organized to construct a line from the centre of the city to the steamboat landing. Capital, \$30,000. It is expected that four cars will be running by July 1, 1887.

#### COLORADO.

*Durango* is to have a street railway.

#### CONNECTICUT.

*Ansonia.* A letter, April 7th, says that a company has been organized, with a capital of \$50,000, to construct an electric railway 3½ miles long, from the Derby steamboat landing to Birmingham and Ansonia. Wires strung over head, says the *Electrical World*, will conduct the electric current, the motive power for which will be supplied by the Housatonic dam, one of the largest in New England.

#### DAKOTA.

*Mitchell* wants street cars.

*Sioux Falls.* R. F. Pettigrew is in the East buying iron and other things necessary for the construction of the street-car line at Sioux Falls. It is expected that two miles of track will be laid and operated this season.

#### GEORGIA.

*Atlanta.* The City Council has passed an ordinance authorizing the Met. St. Ry. Co. to run its cars by electricity.

#### ILLINOIS.

*Chicago.* The North Side cable railway case is still "in the courts," or rather Mr. A. C. Story won't keep out of the courts, although he is promptly check-mated every move he makes.

A voluminous answer was also filed April 25, in the United States Circuit Court, in the case of Nathan Lorie against the North Chicago City Railway Co. and others. This was a bill to prevent the company from laying its cable road on North Clark street and through the La Salle street tunnel. The answer chiefly denies all the main allegations of the bill that the road would be a nuisance, that it was dangerous and depreciated property, and that the ordinances of June and July, 1886, were void. It is also charged that Lorie does not own the building on the northwest corner of Illinois and State streets, as he claims, but that it is owned by Samuel Glickauf, who pretends to act as agent; that the two stores and basement are rented for five years at \$4,200 a year, more than ever was paid before, and this price was obtained in view of the expected location of the cable road. Over six miles of the new road have already been laid, at a cost of \$4,000,000, and it has all been done under the supervision of the city authorities.

The following lines, of the Chicago City Railway Co., are in process of construction:—

51st Street, from Indiana Ave. to State St.—Return same route.

61st Street, from State Street to Wentworth Ave.—Return same route.

26th Street, from Halsted Street to South Park Ave.—Return same route.

22nd Street, from the Lake to the River.—Return same route.

Ullman and 35th Street, from Ullman and 31st Street south on Ullman, to 35th Street; east on 35th to State Street.—Return same route.

State Street and 69th Street, from State and 63rd Street, south on State Street to 69th Street; west on 69th to Halsted Street.—Return same route.

Halsted and 69th Street, from Halsted and 63rd Street, south on Halsted to 69th Street.—Return same route.

Hanover and Butler Street, from 31st Street, south on Butler to 39th Street.—Return same route.

47th Street, from Ashland Ave. and 47th Street, east on 47th Street to State Street.—Return same route.

*Hyde Park Cable Line.* Route: South on Cottage



Grove Avenue to 67th Street; east on 55th Street to Jefferson Avenue; south on Jefferson Avenue; east between 56th and 57th Streets to Hyde Park Avenue; north on Hyde Park Avenue to 55th Street.

*State and 63rd Street Cable Line.* Route: South on State Street to 63rd Street.—Return same route.

The Chicago Terminal Railway and Transit Company has been incorporated; capital, \$12,000,000; to construct a belt system connecting the various depots and the street railway termini. The incorporators are A. H. Dend, Thomas J. Caton, John Gray, Hy. W. Leman, Amos W. Martin, etc.

The experimental railway plant, fixed on the front of Lake Michigan, by the Bidwell Electric and Manufacturing Company, is still there, and progressing.

*East St. Louis.* At Springfield, Ill., April 15, a license was issued to the City Railroad Company of East St. Louis; capital stock, \$100,000; incorporators, R. M. Dreyer, George W. Locke, E. C. Newkirk, Isaac A. Smith, and William H. Stone.

*Hyde Park.* Ordinances for the Cook County Rapid Transit Railroad, the Hyde Park and Town of Lake Horse Railway, and the Union Railway, which had been before the board for some time past, were placed upon file April 18, on the recommendation of the Judiciary Committee.

*Lake View.* At the Trustees' meeting April 18, President Yerkes' ordinance for a street railway on Belmont avenue, Robey, and Roscoe streets was passed. It provides for a single fare of five cents on the Evanston avenue line, as far north as Belmont avenue. The new line passes through the centre of the sub-division of the North Chicago system.

*Olney.* The Olney Street Railway Company will probably have cars in operation by the middle of June.

#### INDIANA.

*Terre Haute.* The T. H. St. Ry. Co. is adding 2½ miles of new track. Mr. Joseph Collett, hitherto vice-president, is now president. Secretary J. R. Paddock reports sixteen cars running, and that they use 76 mules and eight horses.

#### IOWA.

*Boonsboro.* The Rail Fare Box Company have patented a new Fare Box and Change Maker combined. The fare box is declared to be one of the finest made, and the change maker is entirely new—there is nothing in the market like it.

*Des Moines.* The Des Moines Street Railway Company has fixed 24 of the new "fare boxes and change makers" recently patented by the Rail Fare Box Company, Boonsboro.

#### KANSAS.

*Atchison.* The Atchison Rapid Transit Company, organized April 10, by the election of S. B. Glazier, president, S. F. Scott, vice-president, and F. W. Hunton, secretary and treasurer. The company appointed S. F. Scott a committee to make contracts at once for the construction of the line, which will cost about \$100,000.

*Baxter Springs.* A charter for the purpose of constructing, maintaining and operating a street railway in Baxter Springs has been secured.

*Conway Springs and Caldwell* are both expecting street cars. In the former city the council has granted franchises to a company to construct and operate a line; in the latter, a company has been organized and is about applying for franchises for the same purpose.

*Girard.* Dr. G. T. Carpenter, the principal mover in the street railway enterprise, having obtained accurate and reliable figures, states that a two-mile line, with equipment for electric attachments, will cost about \$8,000, and the same length of line drawn by horses, \$5,000; but after the former is ready for business it will cost much less to maintain. Plans will soon be perfected and laid before the public.

*Great Bend.* The stockholders of the Great Bend St. Ry. Co. elected, April 18, D. N. Heizer, president; C. Samuels, vice-president; A. C. Schermerhorn, secretary and treasurer. An assessment of twenty-five per cent. of the capital stock has been levied to be paid in at once. The president was instructed to purchase material and "have the

road constructed as fast as men and means can build it." It was the unanimous decision of the company that the road and rolling stock shall be first-class in every particular.

*Hutchinson.* The street cars are now running. There are ten-minute trips between the Missouri Pacific and Santa Fe depots, and twenty-minute service at each end of the line. These are the cars of the Hutchinson St. Ry. Co., organized 12 months ago; A. L. Forsha, president.

*Jetmore.* A street railway company has been organized at Jetmore, Hodgman county. Capital stock, \$20,000.

*Kingman.* A franchise has been granted the Kingman St. Ry. Co., which provides that they shall begin work on the same by July 1, 1887. We understand that arrangements are already nearly complete by which from three to five miles of track will be laid this summer, which will cost \$50,000.

*Lawrence.* The Rapid Transit Company has been incorporated. Capital, \$150,000. Directors, O. E. Leonard, J. D. Miles, Washington Hadley, William S. Sinclair, George Leis, J. M. Webster, R. H. Tabor, A. G. Eidemiller and T. J. Sternburg—all of Lawrence. As soon as the surveys are completed, and the right of way is obtained, the work of construction will commence.

*Leoti.* "The Leoti City Street Railway Company" has been incorporated. The capital stock is \$25,000, and the directors are W. R. Gibbs, A. G. Wright, T. W. Pelham, W. J. Buchanan, R. E. Jenness and R. W. Cary.

*Lyons.* The Lyons Street Railway Company has received \$10,000 of the \$50,000 subscribed capital.

*Newton.* The capital stock of the Newton Rapid Transit Company is \$50,000. The directors are H. L. Hart, James H. Anderson, Fox Winnie, S. Lehman and A. B. Gilbert. The propelling power will be either steam or electricity. The track will extend about three miles. We may confidently look for the early completion of this road, says a Newtonian, "which will score one more for Newton and the leading town in the Arkansas Valley."

*North Topeka.* Hon. John Francis, at the big boom meeting, said that the Rapid Transit company had bought ten miles of the best steel rails, which were now on the road. He said the Rapid Transit would do much for North Topeka.

*Oberlin.* The Oberlin Street Railway Company have filed a charter with the Secretary of State.

*Parsons.* The Parsons Street Railway Company held a meeting April 18, in the office of the Southern Kansas Investment Company to conclude their arrangements to begin work. The first part to be built will be the Central avenue line extending from Felix avenue on the Northeast Central to Morgan avenue. The construction of the Johnson avenue line will follow at once, and be extended to the Fair Ground addition. The contractor who will have charge of the work, says a correspondent, is now building a line of street railway in a Texas city, "but his job there is almost finished, and he has sent word that he will be here within a very few days to begin work."

*Salina.* The Salina Street Railway Company have commenced putting in two "turn-outs,"—one near South street on Santa Fe, and one on Ninth street near Ash. Material has been hauled to the locations. "The car-line business is increasing so rapidly that they will soon be compelled to add a fourth car."

*Stockton.* The Stockton Street Railway Company has been organized. Capital stock \$25,000, with Charles Woods president.

*Topeka.* The City Railway Company are considering the advisability of putting steam motors on their lines. The same company have concluded to uniform their drivers. Thirty-five uniforms have been ordered from St. Louis, and are blue and have the initials of the company upon them. A charter has been drawn up by George P. Johnson for a new street car line from Kansas avenue on Gordon street to Topeka avenue, thence to Maple Grove addition, and from that point to the reform school. Among the projectors of this road are J. Thomas and J. H. Fouch. It is reported that the new line will be built and operated by the Topeka City Railway Company. The double track of the

Rapid Transit Road is now laid more than a block in front of the state house; it is the most substantial street car line ever built in the west. Workmen on this line are scattered all along Jackson street.

*Wichita.* The Wichita City Railway Company will extend their lines west, from Main street to Maple avenue.

The Princess Motor Line Company has been organized by Oscar Sherman, J. L. Mead, Graham & Jones, etc., to construct a line running south on Main, from the corner of Williams to Howard street, where it will cross the river to Wheeler avenue, west past the Catholic See, then turning north will run to the first section line, and then east to the city. The line will leave the Glendale addition to the north, the East Garfield University addition to the south, as it will also the Richardson addition. The Princess addition will be left to the north, and on this addition will probably be located a suburban depot. The cars will be operated by electricity, and the motor will be of the latest style. An ordinance has been framed and submitted to the city council for approval.

*Wyandotte.* The Metropolitan Street Railroad Company are building a car-house for their cable line. Mr. W. Knight is the architect.

The Inter-State Elevated Railroad Company's extension is now under way, *i. e.*, the grading and laying of tracks on surface had been done to a length of three miles the middle of April.

#### LOUISIANA.

*New Orleans.* Several months have elapsed since the franchise of the Canal and Claiborne Street Railroad Co. was announced for sale; and it is yet "in the market."

#### MASSACHUSETTS.

*Boston.* Thomas J. Mayall has models of his system for elevated railroads on exhibition at No. 67 State street.

The citizens of Boston "as usual" are strenuously opposing all plans and constructions that would tend to disturb the Common in either boundary or appearance. There is only one way in which street railroads can get across the Common, and that way is a tunnel.

At a recent session at the state house Mr. W. P. Cherrington spoke for the laboring men, who protested against the proposed consolidation of all the roads. He asked that the city of Boston purchase and run the various roads in the city, and he further asked that in framing the bill a clause be inserted regulating the hours of labor of the employees to ten hours per day within twelve hours.

At the same meeting Mr. Nathan W. Matthews hoped if any charter is granted the West End Railway Company the road will be made to pay for it. He suggested that the road pay into the city treasury one cent for each passenger. He thought horse railways could sell thirty or thirty-five tickets for \$1, and pay 8 per cent. dividends. He thought the franchise should be sold by public auction.

Very few summer open cars are running. A long, stormy winter and a cold, backward spring keep them under cover, bright and clean, ready for immediate use when weather permits.

Elevated railroads are wanted and talked about a good deal just now in Boston. The Riley, Moulton, Mack and Meigs systems are represented in the city by fine models and intelligent representatives. The Meigs temporary exhibition track, car and motor have been visited and examined by many hundreds of people.

The West End Railroad expects to do something progressive in transportation.

The committee on street railways have given a hearing to the promoters of the electric railway on a road between Boston Common and Jamaica plain, where the Enos suspended car system is proposed to be used, with Daft electric motors.

The Meigs Elevated Railway Construction Company has filed its certificate of payment of \$100,000 capital as follows: In cash, \$50,000, and a contract and agreement between said company and the owners of the Meigs elevated railway system, its letters patent, drawings, models, fixtures, and appurtenances for the use and purposes of said company, for the sum of \$50,000 in the capital stock of said

company, said stock to be delivered after a majority of the subscribers of the \$50,000 paid in in cash certify that a certain experimental structure described in the articles of agreement, by which said construction company was formed, has been completed to their satisfaction, which has been done.

At the meeting of the Board of Aldermen, April 25, a report was "accepted," authorizing the South Boston Horse Railroad Co. to lay down a single track in West Broadway, from Harrison avenue to Washington street, connecting with the tracks of the said company, already laid in West Broadway; also, the right to lay a curved track at the corner of West Broadway and Washington street, to connect with tracks of the Metropolitan Railroad Company in Washington street; also the right to enter upon and use the tracks of the Metropolitan Railroad Company, on Washington street, between West Broadway and Beach street. The right to lay down the tracks in question is upon condition that the whole work of laying the same, the form of rail to be used, and the kind and quality of material used in paving said tracks, shall be under the direction and to the satisfaction of the superintendent of streets, and shall be approved by him. Also upon condition that said South Boston Railroad Company shall agree, in writing, to comply with the conditions imposed, and shall file acceptance and agreement with the city clerk within 30 days from the passage of the order; otherwise it shall be null and void.

By the extension of the street railroad on Broadway, South Boston, to Washington street, passengers will have a shorter and pleasanter and more direct route to stores, depots and business centres.

The South Boston Railroad Company will use, temporarily, the tracks of the Metropolitan Railroad Company in Washington street, between Essex and Beach streets, and in Beach street between Harrison avenue and Washington street.

At the South Boston Railroad Company's headquarters, Broadway and K streets, may be seen car houses and horse stables that are among the most extensive, best equipped and systematized in the country.

*Cambridge.* At the shops of the Cambridge Street Railway Co., an electric motor is being fitted up.

*New Bedford.* The New Bedford and Fair Haven Street Railroad Company and the Acushnet Street Railroad Company, of New Bedford, have voted to consolidate into a company to be called the Union Street Railway Company. The new company is to have a capital of \$260,000, in 2,600 shares. They have elected the following directors: J. Arthur Beavalo, Jonathan Bourne, Charles E. Cook, William W. Crapo, Samuel C. Hart, Weston Howland, Andrew G. Pierce, Abbott P. Smith. Mr. Smith was also elected clerk.

*Salem.* On April 21st the Salem and Danvers Street Railway passed into the hands of the Naumkeag road.

*Stoneham.* At the session of the Massachusetts Legislature held April 21st, the Street Railways Committee reported a bill to change the name of the Stoneham Street Railway to the East Middlesex Street Railway Company, and to extend to December 31, 1889, the time for building its road in Reading, Everett, and Revere.

#### MICHIGAN.

*Grand Rapids.* The cable street railway from Grand Rapids to Reed's lake is "an assured fact." The contract for the work is in the hands of S. B. Tibbetts & Co., of Minneapolis, who have sublet the boiler contract to a Chicago firm, and the iron work to the Michigan Iron Works of Grand Rapids.

#### MINNESOTA.

*St. Cloud.* The St. Cloud Street Railway Company has accepted its ordinance, and will begin work forthwith.

#### MISSISSIPPI.

*Vicksburg.* The street railway connecting the wharf-boat and hotels with the depot, in all two miles of track, has been completed, and cars are now running regularly.

#### MISSOURI.

*Kansas City.* The Metropolitan Street Railway Company are determined to build an extension from Independence avenue north on Woodland avenue "to some street



that will furnish a satisfactory eastern extension." A piece of ground that was a "bone of contention" with the Corri-gan Consolidated Street Railway Company, has been purchased for "a good round price," and a numerous signed petition is ready for presentation to the City Council. The route of the new cable line will be as follows: From Independence avenue north on Woodland avenue to Lexington avenue; thence east to Bellefontaine avenue; thence north to St. John avenue; thence east to city limits.

*St. Joseph.* The Frederick Avenue Railway Company, completed the purchase of the Citizen's Street Railway, April 15; the purchase price being somewhere in the neighborhood of \$85,000. This is the oldest street car line in the city, and its charter gives it the right to build anywhere in the city limits, hence the securing of the stock at this time is considered a most valuable purchase. The line will at once be extended to the northern part of the city for a distance of two miles.

The city council granted, April 18, to Lillis & Co., Kansas City, the franchise for a cable line to traverse parts of Fourth, Jule, Francise and Seventh streets, with light amendments to the original draft of the franchise. Work is to be begun within four months.

*St. Louis.* A contract has been closed with the Wright Construction Company, Chicago, to superintend the changing of the horse lines of the Citizens' Railway Company to the cable system. Mr. Julius S. Walsh is president of this enterprising street railway company, and that in itself is a guaranty that the change will be for the better, and that everything will be first-class. Cast iron yokes will be used, and these are now being manufactured by the St. Louis Malleable Iron Company, the New Albany Rolling Mill, and McMurray Judge and Rankin. The slot rail contracts have been awarded and the rails are being made by the New Albany Rolling Mill, and at Danville, Pennsylvania. The track rails will be on the ground in a few days, from the Johnson Steel Street Rail Company, of Johnstown, Pennsylvania, weighing sixty-five pounds to the yard. The contract for cement was awarded to the Empire Warehouse Company, of Chicago; bolts, to Dayton, of Cincinnati. A full corps of engineers are at work, and the road will be opened to the Fair Grounds in September next. The road will be constructed under the National Cable Company patents and will be first-class in every respect, containing the latest improvements, and no expense will be spared in the construction.

The first application in this city of electricity as a motive power for running street railroad cars was made April 26, on the Washington Avenue Road. The test was considered highly successful, and as soon as the necessary machinery and apparatus can be attached to the cars the road will be run by electricity.

#### NEBRASKA.

*Hastings.* The Hastings Street Railway Company is "busy getting materials for the line of street cars." About five miles of track will be laid this summer.

#### NEW HAMPSHIRE.

*Concord.* A new motor car has just been put on the motor line. It was built from a design of the superintendent, Mr. Humphrey, of the Concord, New Hampshire, Horse Railroad, and has a seating capacity of thirty-two. It is claimed to be superior in many respects to any in present use.

#### NEW JERSEY.

*Asbury Park.* Tenders are solicited for an electric railway.

*New Brunswick.* It is intended to substitute electricity for horses on the street railway here.

*Jersey City.* The following directors were elected, April 11, for the Jersey City and Bergen Railroad Company: Charles B. Thurston, William Keeney, Edmund Smith, Alfred L. Dennis, F. Wolcott Jackson, Edward F. C. Young, Henry D. Welsh, James B. Vredenburg, John P. Wetherill, William Brinkerhoff, N. Parker Shortridge.

#### NEW YORK.

*Brooklyn.* The new Brooklyn Heights Railroad Company, formed to build a road in Montague street, from the

Wall street ferry to Court street, has been formally organized: President, S. B. Chittenden, Jr.; vice-president, J. J. Pierrepont; secretary, G. W. Chauncey, and treasurer, M. Chauncey. The company was started as a cable company, but it has been decided to use electricity as a motive power. The opposition to the road in Montague street, it is claimed, has been in the main overcome, and there is a demand for the road. The Nassau Cable Company claims Montague street as a portion of its route, by means of which it will connect with Wall street and Fulton ferries to the bridge.

The Nassau Cable Railway Company, which failed two or three years ago to get a franchise to build its road in some of the principal streets of Brooklyn has renewed its application to the board of aldermen.

*Ithaca.* Messrs. Haines Brothers are adopting the Daft electric railway system, and the Safety Electric Railway and Power Company (J. Murray Mitchell, president,) are doing the work. Great interest is taken in the new road by the students of the Cornell University.

*New York.* Three hundred property-owners met, on April 16, to oppose the construction of the Arcade Railway: J. J. Astor, O. B. Potter, Henry Hilton, W. D. Sloane, E. S. Higgins, Samuel Lord, P. T. Barnum, J. M. Constable, C. L. Tiffany, E. S. Jaffray, Eugene Kelley, E. T. Tefft, Robert and Ogden Golet, Amos R. and Amos F. Eno, J. A. Roosevelt, L. M. Bates, Morris K. Jessup, W. E. Dodge and Peter Marié were among those present at the meeting. They passed a resolution to oppose, by injunction, suit or otherwise, the validity of the alleged charter of the Arcade Company. Albon P. Man, John F. Dillon and Noah Davis have been retained as the legal representatives of these property-owners in this fight.

The Corporation Counsel's assistants, Messrs. Dean and Wickes, appeared before Justice Donohue, April 25, in the Supreme Court, Chambers, to oppose the application of the Metropolitan Transit Company for a commission to determine what sum the company shall pay the city for the use of Broadway for an elevated road. The company lays claim to right of way in Broadway between Chambers and Forty-third streets. The hearing was postponed at the request of General Wingate, who wished an opportunity to examine the Corporation Counsel's answer. The Corporation Counsel opposes the application on the ground that the company has never been duly organized or incorporated, and if it has, that its rights have lapsed through non-use, and that it has no rights in Broadway or the Boulevard, that the legislative acts for the benefit of the company are unconstitutional; and that the Broadway and Seventh avenue and the Manhattan companies should be made parties to the proceeding. It is alleged that the welfare of the city will not be served by the construction of the road, and that the company does not possess the requisite means properly to execute the work. Insurmountable difficulties are alleged to stand in the way of the execution of the proposed scheme.

There is considerable misapprehension as to what is required of the surface railroad companies by their charters. The mayor is under the impression that the companies are required to keep their roadway between the tracks clean. Such is not the fact. The charter of the Seventh Avenue Company provides that it "shall pave and keep in repair" its roadbed. The charter of the Third Avenue Company is worded in the same manner. That of the Sixth Avenue Railroad Company provides that the company "shall keep its roadbed in good repair." That of the Eighth Avenue Company is similarly phrased. The charter of the Ninth Avenue Company provides that the company "shall keep the space for two feet each side of the same (the roadbed) at all times in thorough repair." The charter of the Dry-Dock, East Broadway and Battery Company, speaking of the roadbed, says: "Subject to such reasonable rules and regulations in respect thereto as the Common Council may by ordinance prescribe." That of the Christopher and Tenth Street Railroad provides that the company "shall keep in good repair the pavement the width of their tracks and eighteen inches upon the outside of the same." The charter of the Twenty-third Street Company provides that

the company "shall remove and dump snow on Twenty-eighth and Twenty-ninth streets, First to Second avenues, when of sufficient depth to interfere with ordinary travel." The Broadway and Seventh avenue Railroad Company has the same restriction as the Dry-Dock Company.

The Manhattan Railway Company is busily occupied in putting in shuttle tracks at convenient distances along its route up Third avenue. One riding between Ninth and One-hundred-and-twenty-ninth streets, will encounter them at a great many intervals. The new tracks are being constructed in the center of the street between the existing tracks. At Ninth street there is a stretch of this middle track which is already in use for switching off trains from the down track and shifting them to the up track. The rails run some three blocks. At Fifteenth street there is another switch of this kind. At Twenty-third and Twenty-fourth streets there are stretches of track, and so at intervals at Forty-second, Fifty-ninth and Sixty-ninth streets, and thence almost continuously to One-hundred-and-twenty-ninth street, this entire track, by gradual accretions, has been extended.

Col. Hain was asked if it was not the purpose of the company ultimately to connect these detached strips of track and make a continuous line for express trains. "No," he replies, "at least, not at present. The tracks are to be used for switching off disabled trains, or in case of blockade through fire or otherwise."

*Pelham Park* is to have an electric railway.

*Long Island City.* The incorporation of the Riker Avenue & Sandford's Point Railway Company was reported in the December GAZETTE. The line will be opened June 1st.

#### NORTH CAROLINA.

*Wilmington.* The length of track to be constructed by the Wilmington Street Railway Company, reported in our last issue, is eight miles, two-thirds to be built forthwith.

#### OHIO.

*Lima.* An electric street railway is being built at Lima, Ohio. It will be the Van Depoele system. The road is being built of the Johnson Steel Street Rail. It will be equipped with Pullman cars of the latest style, furnished in cherry and mahogany. About five miles of track will be laid and the road will be in operation within the next thirty days. B. C. Faurot is president, and F. L. Langanen is secretary and treasurer.

#### PENNSYLVANIA.

*Allegheny City.* The Bentley-Knight electric railway system, recently described fully in THE STREET RAILWAY GAZETTE, is to be adopted by the Observatory Hill Passenger Railway Company. The line will be about three miles long, with a ten per cent. grade. It will have both conduit and overhead conductor.

*Lancaster.* The Lancaster City Street Railway Company are about to extend their road a distance of about a mile and a half, and have purchased the materials from Messrs. W. Wharton, Jr., & Co. They have also purchased, from J. G. Brill & Co., six closed and two large summer cars.

*Pittsburgh.* The Detroit Electrical Works are constructing two cars for the electric railway here, which will be about a mile long.

*Reading.* The Perkiomen Avenue Passenger Railway Company propose to adopt electricity on their system.

#### TENNESSEE.

*Memphis.* The Memphis, Greenwood and Prospect Railroad Company, (in which Mr. J. A. Van Hoose is largely interested,) is now engaged in building a street railroad in Memphis and suburbs, to be operated by steam motor power. There will be two lines, each of about six miles in length, including side tracks, and each will have its terminus on Monroe street at Third, thus reaching the heart of the city. The southern division will run to a large park, drill ground, etc., on Cane creek, the waters of which will be utilized in making a beautiful lake of fresh running water. These improvements in connection with a boat house, natorium and restaurant, will be made by the Chickasaw Land Company, who are large stockholders in the railroad company, and whose extensive and valuable property begins about two and one-half miles south of Court Square and is opened up by this railroad.

The eastern division will run east to the race track. Both lines will be pushed as fast as possible. The motors, rails and cars have been contracted for, and it is hoped to have the road in operation by the end of July. The officers of the company are: T. J. Latham, president; J. A. Van Hoose, vice-president; T. A. Lamb, secretary and treasurer.

*Nashville.* A correspondent, writing April 15, says: The three street railroads in this city are soon to be consolidated and operated under one management. A committee was appointed to report a basis of consolidation. This committee agreed upon a basis and recommended a consolidation, under which a person could, for one fare, go to any part of the city. The East Nashville Company and the South Nashville Company are ready to consummate the consolidation upon the basis recommended by the committee, but some of the small stockholders in the McGavock and Mt. Vernon Railroad are putting obstacles in the way.

#### TEXAS.

*Sherman.* The new street railway will be about five miles long. Major H. Burnett and C. C. Jones are the principal promoters.

#### VERMONT.

*Rutland.* The Rutland Street Railway Company has over eight miles of tracks, running twelve cars with forty-three horses. Mr. John N. Woodfin, (late secretary of the company,) is now president, W. Quin having resigned on account of ill health.

#### WISCONSIN.

*Milwaukee.* At the last meeting of the "old council," April 19, a new ordinance was "introduced by the chair" to authorize Robert Nunnemacher, Hermann Nunnemacher, Rudolph Nunnemacher, H. S. Benjamin and others to build a cable road from the lake on Oneida street to Wells, to Third, to Cedar street, to the city limits. The syndicate is said to have a capital of a million dollars back of it. If it secures the valuable franchise, it intends to go out on Vliet street to the village of Wauwatosa.

#### WYOMING.

*Cheyenne City.* The Cheyenne Street and Circle Railway Company, with a capital stock of \$150,000, has been incorporated. Work on the line will be commenced at once.

### Business Notes.

The Wright Construction Company (Augustine W. Wright, C. E., president) has been engaged to superintend the conversion of the Citizen's Ry. Co.'s horse railway, St. Louis, to the cable system.

M. M. WHITE & Co. are shipping switches to every part of the Union, and report business as AA 1.

Mr. W. J. HAYCOX, of Cleveland, O., is feeling happy over the increasing demand for his patent door fastener from all parts of the country.

THE Street Railway Supply Co. (late Higley Car Jour. Co.), Cleveland, O., has rebuilt its works, and is full of orders.

GARDINER & Co. are full of orders for car seats, and still want more, to judge by their handsome advertisement in the GAZETTE.

THE Hazard Manufacturing Co., of Wilkesbarre, Pa., is running full time, and is making competition somewhat lively in the cable rope business.

THE Way Foundry Co., of Philadelphia, reports contracts recently made with most of the local street railway companies for switches and track supplies.

Metropolitan R. R. Office,

Boston, April 16, 1887.

I heartily endorse all that President Cummings says in April number of THE STREET RAILWAY GAZETTE. We have had a more lengthened experience with the Sand Boxes, and I think I can truthfully say that no street railway can afford to do without them.

(Signed)

C. A. RICHARDS,  
President M. R. R. Co.

To the Car Track Friction Appliance Co., 19 Tremont Row Boston.



# The Street Railway Gazette.

VOL. II.

CHICAGO

JUNE, 1887.

NEW YORK

NO. 6

## Andrew Smith Hallidie, Esq.

THE INVENTOR OF THE CABLE RAILWAY SYSTEM.

Inventions come by inspiration. One drizzly day, in 1869, two men stood conversing at the corner of Stockton and Jackson streets, San Francisco. They beheld a street car approaching, up the steep grade from Dupont street to Stockton, along Jackson street. The car was drawn by five horses; one of them slipped, and the heavily-laden car slid back, down hill, dragging the fallen horse with it, to the consternation of those looking on. One of the two friends standing at the street corner was an engineer (civil and mechanical) of repute; the other, a member of a lithographic firm of high standing, exclaimed to his companion, with a deep tone of impatient pity, "Andrew, why don't you go to work and invent something to pull street cars safely up steep grades and prevent such accidents?"

That request had the same effect on "Andrew" as the commandment had on Moses to go and deliver the Israelites from the miserable bondage of Egypt. And he went and did it—successfully. Mr. Andrew S. Hallidie had been prepared, for some time previously, for the invention of the much needed contrivance to propel street cars instead of horses; and some of the incidents of his life are more romantic than fiction.

The subject of this biographical sketch is of Scotch parentage; and he is fifty-one years of age, and has been a resident of San Francisco, California, thirty-four years. In early life Mr. Hallidie studied for an engineer; he spent three years in the shop and drawing office; but at seventeen he was in California—where he mined for gold for five or six years, supplementing his mining operations by surveying roads and water ditches. Before he was twenty he built a suspension bridge and aqueduct across the middle fork of the American River, which had a span of 220 feet, and the water conduit had a section of three feet by two.

Mr. Hallidie designed and operated various improvements in mining machinery—being himself a practical miner (above and under ground). He ran a quartz mill in 1856. And a year later, extemporizing machinery on the American Bar of the middle fork of the American River, he made the first wire rope ever used in the Golden State, and which was

employed on an incline of 24°, 1600 feet long, for lowering the rock of a quartz mine to the stamp mill below. At that time he was stimulated to renewed energy to work out his second fortune—having lost in 1855 all he had previously made, by the sudden rise of the river, whereby even his claim was destroyed. And for a few weeks he made from \$15 to \$20 per day—sharpening, tempering and repairing picks and drills for the miners in the vicinity. During 1857 he ran the lines and superintended the running of a tunnel through a spur in the mountain for a water course; and he

hit his levels midway within half an inch! his surveying instruments being made by himself on the ground.

In the winter following, after repairing all the old guns and rifles obtainable, Mr. Hallidie, in company with nineteen others, went after the Indians that had been robbing and murdering whites. And after capturing two bands, he and his companions and prisoners were snowed in, and almost starved for nearly a month.

Mr. Hallidie's experience in California, between 1852 and 1858, was that of a pioneer engineer, a miner and prospector; but by all kinds of people, being young and enterprising and daring, he was treated kindly. He barely escaped with his life from a premature explosion of a blast in a shaft at the main end of a 600 foot tunnel; he was soon after caved in and covered up by a falling bank of earth; and while putting the finishing touches on his suspension bridge the scaffolding gave way and precipitated him twenty-five feet on to the rocks below. And, at another time, he went over the falls and rapids of the American River for a mile and a half, clinging to a long stick of timber. And, later, in going by Concord coach from Nevada City to Lincoln, he was run away with by four horses which had been left temporarily standing in front of the hotel at Grass Valley; and he crawled through the small window of the front seat on to the driver's box—and kept the brake on while the maddened horses flew down the hill, the reins flying about their legs—and held on until the horses dropped through exhaustion. He had other like experiences peculiar to early life in California.

For some years Mr. Hallidie was engaged in designing and building bridges, more particularly wire suspension bridges, of which he has erected about fourteen—in Cali-



*my family*  
*A. S. Hallidie*

fornia, and as far north as Fraser river in British Columbia—of spans from 220 to 350 feet.

In 1858 he erected works in San Francisco for the manufacture of wire rope, in which he has been engaged ever since; and from which has developed the present California Wire Works—a concern with half a million dollars capital, employing 200 men—of which he is president and manager.

His familiarity with the needs of the rough mining regions of California suggested the invention of the Hallidie wire tramway or rope-way, for the transportation of ore and other material over mountainous and difficult roads. He took out a number of patents for this; it has been very successful, and hundreds of these aerial lines are in use in this country and elsewhere.

It was immediately after maturing this system that he invented the cable railway, which he perfected a year or two afterwards, and put in practical operation. He was urged to this more particularly by seeing the struggling and harsh treatment of the horses engaged in hauling the cars up Jackson street hill, as already intimated. It was in the line of his investigation and consonant with the drift of his inventive thought. For all that, it is very doubtful if he would have been able to carry out his street rope-way project, and put his invention in practical shape, if it had not been for the confidence that two friends had in his mechanical skill. Others had discouraged him, and many laughed at his visionary ideas. But the two faithful friends gave him hearty moral support, and when he had failed to interest moneyed men in his scheme, they joined him and lent pecuniary aid to carry out his plans—which were put in execution by constructing a cable road on Clay street, in the city of San Francisco, with a double track of  $3\frac{1}{2}$  feet gauge, three-fifths of a mile long, and raising up to an elevation of 328 feet in that distance, crossing five streets, many at right angles and with level crossings.

We described this road and its inauguration (in the summer of 1873) in our April number, and gave an interesting account of the first trip made over the road by the inventor. For some years Mr. Hallidie gave his personal and close attention to its workings, and to the general mechanical success of the system; in fact, he was so thoroughly wrapt up in the solution of the mechanical difficulties and the simplification of the details, that he did not as thoroughly protect his invention as he might have done if he had appreciated its financial as much as its scientific value. He took out a large number of patents, however, many of which have been litigated successfully, and have got into the hands of a company that has bought up a considerable number of other patents bearing on the cable railway system.

He has also patents in most of the European countries, and in the Australian Colonies his system has been introduced on a large scale. And besides his numerous cable railway patents, he has several other inventions, from an animal trap to a suspension bridge, making fully one hundred patents in all.

Neither is his active mind and sympathizing heart confined to the meditation of "cunning inventions," for Mr. Hallidie is interested in everything that helps to elevate mankind. In 1868 he was elected president of the Mechanical Institute of San Francisco, of which he had been an active member, and he continued its president for ten years, during which time the institute rose—principally through his personal efforts and energy—to the commanding and strong position it has since maintained. Twice Mr. Hallidie desired to be relieved, but it was only after he was compelled to go abroad for health, and on business, that they consented to accept his resignation. He is a trustee of the Mechanical School, endowed by Mr. James Lick with \$540,000, which will be available within a year.

We are indebted to the Hon. A. J. Moulder, secretary to Mayor Pond, of San Francisco, for valuable testimony concerning Mr. Hallidie. It is not uncommon for enquiries about San Francisco street railways to be directed to the Mayor, and we notice from foreign papers that his honor gives all the information obtainable to enquirers in many lands. There being no other source from which to obtain the information desired, we did the same as others. And

the Mayor's Secretary says of Mr. Hallidie: "He is not only eminent as a mechanic, an inventor, a manufacturer, and an executive officer of many public institutions, but he is one of the best fellows in the world—and 'best fellow' means a deal in California. His services as president of our Mechanics' Institute, for many years, and as chairman of the finance committee of the Regents of the University, have been signally successful. He is a writer of ability—(see an article from him in the April number of the *Overland Magazine*). He has an extensive library, and *he uses it*. \* \* \* He has become very rich, out of his patents, etc."

From other sources, we learn that Mr. Hallidie has been a Regent of the University of California for 19 years, and still continues one. In fact, he assisted in the organization of the University, and was one of the founders of the San Francisco Public Library; his address at the opening thereof, June 7th, 1879, is now before us, and it shows that the inventor's mind is attentive to details with everything he undertakes. His address before the Mechanics' Institute (in 1876) on "Trade Tuition; Its Status at Home and Abroad," (which is in a 35-page pamphlet) shows extensive observation. He is a member of the Manufacturers Association of California, of which he was for some time president, and the way his last address before the association is recorded in the proceedings, is characteristic. It is said: "President Hallidie then read the following carefully prepared and important address." In a word, most of what he does is "carefully prepared and important," and that seems to be one of the secrets of his remarkable success. And no wonder, therefore, that his services are in such universal demand. There does not seem to be an institution of any account in California without the stamp of his genius upon it. He was, for some time, a vice-president of the Art Association; he is a member of the Academy of Sciences, and of the Geographical Society of San Francisco.

Mr. Hallidie was a member of the Board of Freeholders who framed a charter for the city of San Francisco. He is a prominent member of the Board of Trade, and of the Chamber of Commerce, and is chairman of the Committee on Education, and of various active charitable organizations in the city where he lives.

Notwithstanding his great activity in his own country and at home, his world of observation is not by any means confined to the western slope of the Rocky Mountains. In 1851 he visited the great London Exhibition, and the Paris Exhibition in 1867; also, the Centennial Exhibition of 1876, and the New Orleans Exhibition in 1885. He has visited most of the technical schools in the United States and abroad. And he was president of the San Francisco Industrial Exhibition from 1868 to 1878.

Mr. Hallidie's traveling days are not yet over, it seems. In the April GAZETTE it was mentioned that last year he visited Melbourne, Australia, where an excellent and prosperous cable railway has been constructed. About next August, we are informed, he hopes to pay another visit to New England and Europe, and in London he will examine into the "subway railroad," now being successfully built under the River Thames, and which is intended to be operated with the Hallidie cable system.

*Lawyer and client.* A case has occurred in New York showing how lawyers do not rob their clients. Francis W. Whittaker, better known in the sporting world as "Pop" Whittaker, who was run over and injured by one of the cars of the New York and Harlem Railroad, obtained a judgment in the Supreme Court against the company for \$10,646.73 on March 24, 1884. He made an agreement with Counselor Truax, who conducted his case, by which Mr. Truax was to have \$5,000 of the damages allowed him. Subsequently, however, the company settled with Whittaker for \$3,500, and made a satisfaction-piece. An order vacating the satisfaction of the judgment has now been declared by Judge Freedman, except as to Whittaker's share, giving Mr. Truax permission to prosecute the appeal for the suit which is still pending.



### Cable Railways.

Cable railways are now in operation on the streets of San Francisco, 51 miles; Chicago (South Side), 26½ miles; Kansas City, 27 miles (including lines in course of construction); Cincinnati, 7 miles; Philadelphia, 5 miles; St. Louis, 3 miles; New York, 3 miles (with much more in immediate prospect); Los Angeles, 2 miles; Hoboken, ¾ mile, and Omaha has 3 miles projected; also in Brooklyn, Washington, Nashville, Pittsburgh, Milwaukee, Peoria, Lincoln (Nebr.), Denver, and Oakland (Cal.) Total length in the United States, about 200 miles.

The cable system finds favor in other countries. In Melbourne, Australia, a cable street railway is in successful operation, and more is being constructed, which, when completed, will make 34 miles of "very substantial double track cable road." And at Sidney there is a cable road (double track) 1¾ mile long.

Great Britain follows. In London (England) there is a line ¾ mile (i. e. 1½ mile of cable) in operation, and new cable lines are in prospect, beside that now being constructed under the Thames; and, in Birmingham, also, 2½ miles of cable road is in course of construction. In Edinburgh and other British towns the cable mode of propelling tramway cars is being favorably discussed.

The Celestial Empire (China) has already adopted this modern means of passenger conveyance. As mentioned in the STREET RAILWAY GAZETTE for January last, there is a cable tramway from Hong Kong to its residential suburb Peak.

### A Valuable Franchise Expiring.

The Canal and Claiborne Street Railroad Co., New Orleans, the official value of whose property was stated in the GAZETTE for October last to be \$223,664.74, is peculiarly situated legally. Having obtained an injunction against the city, to restrain the council from interfering with the company's operations after the expiration of its franchise (May 7) unless the amount of the appraisers' valuation should be paid, it came up for argument, May 16, in the Supreme Court of Louisiana, the action of the lower court having been against the company. The object of the railway company seems to have been to force the city to buy their property at the price named. The city's counsel (Attorney Rogers) said:

"The corporation does not own the streets or the rights of way over and through them. The property is in the public. The right of way or use is simply a power of administration for public purposes; hence there is no property rights involved. A use was given to the railroad company for twenty years, and no longer. This use was accepted under conditions and under the conditions enjoyed. The time, twenty years, has elapsed, and the use of the streets returns to the power which granted it, and in whom abides the sale and only right of control. There has never been a surrender of dominion by the State or city. Such a grant would have been void. It can not be presumed.

"On the 7th of May, 1867, the city sold the right of way over and through certain streets for the construction and working of certain railroads. The terms used in making full description are 'right and privilege.' The contract provides for the building of certain tracks, fixes the rates of fare and imposes other conditions as to conduct of the business. There is also contained a privilege of reversion—that is, not of any property granted or sold by the city, but of the rolling stock, equipments and fixtures. In other words, upon certain appraisement the city has the privilege of having this property revert. She can not take it without providing she wishes it. Unless she so wishes it remains to the company. There is in the contract only a saving clause to the company—that the city can have it if she desires it by paying for it."

The Supreme Court took the matter under advisement till May 23, when the Court declared in favor of the City of New Orleans, saying it was not bound to buy the company's "railroads, rolling stock, equipments and fixtures," and that it had full right to re-sell franchise to any bidder.

### Construction, Equipment and Maintenance of American Street Railways.

BY AUGUSTINE W. WRIGHT.

(Continued from page 95.)

Boxes to be of 1" stuff, surfaced one side. Bars 3"x6," surfaced four sides, clear pine.

#### GUTTERS.

All urine gutters and air ducts to be placed in position according to plans. Urine gutters to have sides of 2"x12" common pine, with strips 1"x2" nailed on the inside, with an inclination of ten inches in the length of gutter, to catch basin, to which proper connections shall be made. Iron covers over same to be let into the floor at least ¼ inch more than the thickness of the iron, and to have a true bearing throughout their length. Air ducts to have covers of 2" pine, perforated with holes 1½" diameter, and five inches apart, proper supports to be framed to carry these covers.

#### FIRST STORY FLOORS.

The entire first story will be covered with common pine boards, surfaced one side, and bedded in hot asphalt and well nailed to joists. Upon this, in all alleys, there will be a wearing floor of common pine, 3" thick. Posts carrying second story will be 10x10, surfaced four sides, and corners chamfered, of good and sound pine lumber, sawed square, all to have good and true bearings on plinths, and set plumb and true.

Corbels 10"x12"x4"—0", dressed four sides and cut to pattern, and well spiked to posts.

Cordties dressed one side to 1⅞", and depth corresponding to girder. Girders 4"x14"—6"x14"—6"x16", as shown on drawings. To be sized of equal height over corbels, to true and level bearing. To be well bolted, as shown on plans, and nailed to corbels. Spans over 16 feet to be packed and bolted.

#### SECOND STORY.

Joists to be 2"x12", laid 16" centers, all to be of equal depth on bearings and bridged each 8'—0" of length, with 1½"x3", cut to fit, and well nailed with 10d nails. Frame all necessary headers and trimmers around chimneys and ventilators, and wherever required.

Floor to be of dry, common fencing, dressed and matched, all loose or unsound knots to be cut out and floor laid close and well nailed with 8d nails.

Posts to be 6"x6" or 10"x10" as shown on plans. Cut in lengths to form roof pitch of ½" in 12"; corners chamfered and set plumb and true; corbels for same to be 10"x12", cut to pattern and securely nailed to posts.

Girders 3"x12"—6"x12"—6"x16", according to plan. Sized over corbels to level and uniform bearing.

Roof joists to be 2"x12", laid 16" centers, sized on bearings, well bridged, each 8'—0", lineal feet, with 1½"x3" stuff, securely nailed with 8d nails. To be covered with common boards, dressed one side to ⅞", all loose or unsound knots, shakes, or imperfections to be cut out, well nailed at each joist with 10d nails. Furnish and cut all wall plates 2"x4" for proper nailing of roof felt to brick walls.

#### VENTILATORS.

There will be — ventilators. For construction see detailed drawings.

#### PARTITIONS.

Unless otherwise specified, partitions will be of 2" pine, surfaced two sides, and joists covered with battens on one side, 2½" wide. Girts for same, 2"x6", dressed four sides.

Stall partitions will be of 2" common pine, surfaced two sides, to 1¾ and 3'—6" high, stood perpendicular, with lower end let into floor one inch, and upper end held by oak caps, cut to pattern, and each end of said cap securely fastened to posts with iron fastenings. Twenty-two inches above the top of this cap a girth of oak, 2"x4", dressed four sides, will be inserted to hold the iron partition rods in place between horses.

All double stalls will have swing bars of oak in two pieces, the lower, 2" x 12" x 5'-4", hung with iron screw rods, swivel joints, to the upper 2" x 12" x 8'-0". The latter will be

hung to the manger at its front end, with a chain connection, and to the plates on top of stall posts at its rear end by 1/2" iron rod, with chain and wagon break attachment at its lower end, so that it can be readily detached and dropped to the floor.

Stall plates on top of posts will be of pine, 2" x 6", doubled over all double stalls.

Stall posts will be of oak, 6" x 6" x 8'-0", dressed on four sides, and corners chamfered. All posts set plumb and true, and containing a harness pin, turned from oak or ash.

Feed alley partitions will consist of three pieces, 1" x 10", common pine, surmounted by one piece, 2" x 16", dressed one side.

DOORS.

Doors to be made in accordance with detail drawings. Carpenter to furnish lintels, 4" x 8", dressed top and one side, for all doors and windows; also rails for all sliding doors and hung doors in most substantial and workmanlike manner.

WINDOWS.

All window frames and sash to be made according to details and set in accordance with plans, plumb and true.

MANGERS.

The mangers will be built of oak, top and front 2" x 12", and thoroughly fastened and secured in plan.

DOOR SILLS.

Door sills, with exception of three stern sills, will be of oak four inches thick, sixteen inches wide, and six inches longer than opening in brick wall.

The following is an itemized bill of the lumber used in the construction of this stable.

Fig. 60.

	1280 pieces	Inches.	Feet.
First floor joists	160	2 x 4,	14
First floor posts	112	2 x 4,	10
First floor posts	2	10 x 10,	14
First floor corbels	112	10 x 12,	4
First floor corbels	2	10 x 12,	12
Second story girders	128	4 x 14,	14
Second story girders	80	6 x 14,	20
Second story girders	28	6 x 14,	16
Second story girders	4	4 x 14,	12
Second story joists	177	2 x 10,	10
Second story joists	1400	2 x 12,	14
Second story posts	28	6 x 6,	7
Second story posts	28	6 x 6,	8
Second story posts	54	6 x 6,	9
Second story posts	2	10 x 10,	9
Second story corbels	110	10 x 12,	4
Second story corbels	2	10 x 12,	12
Roof girders	126	3 x 12,	14
Roof girders	78	6 x 12,	20
Roof girders	2	6 x 16,	30
Roof joists	1400	2 x 10,	14
Roof joists	177	2 x 10,	10
Air ducts, sides	112	2 x 12,	14
Air ducts, sides	14	2 x 12,	10
Air ducts, tops	56	2 x 12,	14
Air ducts, tops	14	2 x 12,	10
Air ducts, bottom	56	2 x 10,	14
Air ducts, bottom	14	2 x 10,	10
Gutters, sides	192	2 x 12,	14
Gutters, bottoms	96	2 x 5,	14
Stall partitions	720	2 x 12,	14
Partitions	400	2 x 12,	16
Feed alley partitions	96	2 x 16,	14
Feed alley partitions	288	1 x 10,	14
Bridging	700	1 1/2 x 3,	10
Wall plates, etc.	140	2 x 4,	16
Lintels, windows	25	4 x 8,	16
Lintels, doors	20	4 x 6,	16
Stall caps	220	2 x 6,	14
Ventilators	36	4 x 4,	16
Ventilators	100	1 1/2 x 1 3/4,	14
Crown mouldings	35	3	14

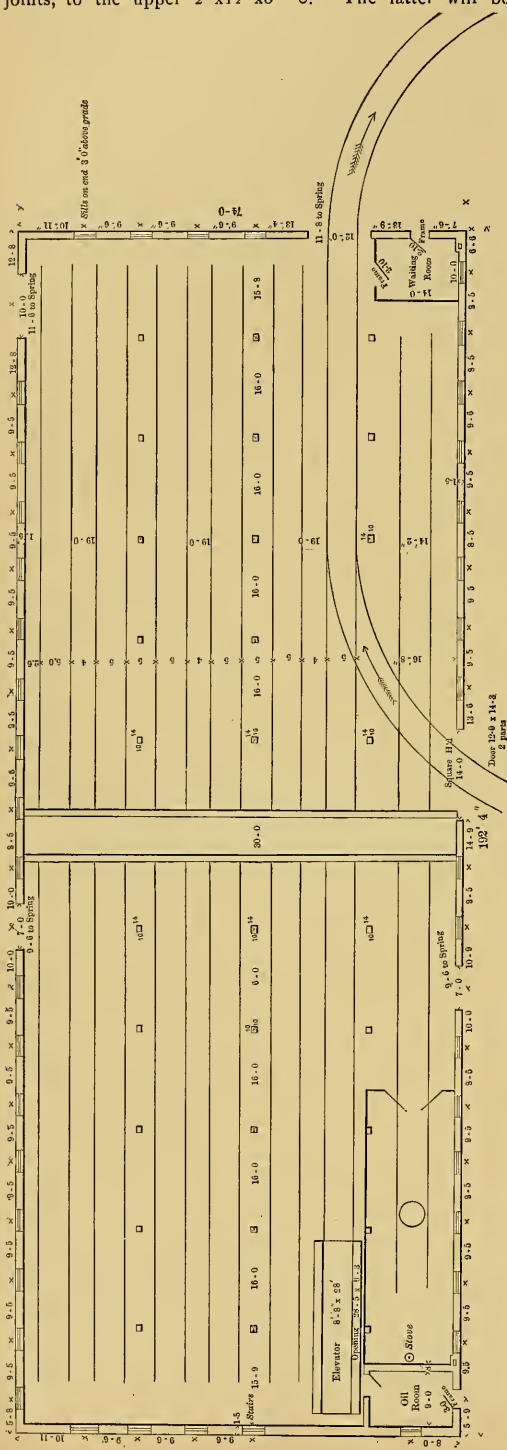



	Inches.	Feet.	
O. G. Battens	500 pieces 2 1/2	16'	
Quarter round	400 " 1 1/2	10	
Casing	100 " 1 3/8	16	Dressed one side.
Cord ties	245 " 2 X 14,	4	Dressed one side.
Cord ties	245 " 2 X 12,	4	Dressed one side.
Gutter strips	192 " 1 X 2,	14	
Door bars	16 " 3 X 6,	8	Dressed 1 side 3rd clean.
Door bars	25 " 3 X 6,	16	Dressed 1 side 3rd clean.
Door bars boxes	32 " 1 X 6,	16	Dressed 1 side 3rd clean.
First floor	2" X 10',	5000 pr. Bm.	
First floor	2" X 9',	37500 pr. Bm.	
First floor	2" X 16',	16000 pr. Bm.	
Second floor D & M C F	1" X 16',	30000 pr. Bm.	
Second floor D & M C F	1" X 16',	40000 pr. Bm.	
Roof C B S 1 side	1" X 16',	30000 pr. Bm.	

Oak.

	Inches.	Feet.	
Stud posts	360 pieces 6 X 6,	8	Dressed to pattern.
Stud caps	216 " 2 X 4,	7	Dressed 4 sides.
Stud caps	8 " 4 X 4,	8	Dressed to pattern.
Stud caps	240 " 4 X 5,	8	Dressed to pattern.
Stud mangers	216 " 2 X 12,	14	

bars complete; 288 hitching rings, 2" diameter; 288 staples for same, 3" long; 96 angle irons, size each 8" X 3/4"; 384 wagon straps; 538 machine bolts, 16" long, 2" thread; 264 machine bolts, 12" long, 2" thread; 252 machine bolts, 10" long, 2" thread; 2108 cast iron washers, 3" diameter; 250 T anchors; 40 wall hitching rings; 68 window weights, 17 lbs.; 32 window weights, 7 lbs.; 216 window weights, 10 lbs.; 1600 tin for strap iron, 1 1/2" wide; 1000 tin for strap iron, 1" wide.

CAR HOUSES.

The general plan adopted for the car house, is not a matter of so much importance as that of the stable, and it will vary under different circumstances.

The following description of a car house adjoining the afordescribed stable embodies my idea of such a building at that point.

The building faces south on Belden av., with a frontage of 74 ft., and west on Racine av. 192'-4". It is two stories high, of brick, and lighted from four sides. Fig. 60 is a ground plan.

It contains seven tracks on the first floor, with room for forty cars.

At the southeast corner a waiting room for passengers is provided, 10' X 14'.

The cars enter from Racine av. through a door 86 feet from the front, and pass out through a door in Belden av., returning to Racine by a reverse curve.

The horses are brought from the stable and changed in the car house.

Along the wall, adjacent to the waiting room, twenty-four closets are provided with Yale locks. Each closet is used by a conductor and his driver, both having keys. Here they keep waterproofs, overshoes, etc., and do not, consequently, have to carry these articles upon their car.

The transfer table is located 94.75 feet from the front of the building. When it is put at either end, as is frequently the case, if it is desired to get out a certain

car at the other end of the track, twice as much switching must be done to reach the car as by this location.

Figure No. 61 shows the transfer table, which is built so that the pit requires only four inches of depth, and horses can walk over it anywhere.

Beyond the transfer pit is located the wash room, which contains a stove to heat it in cold weather. Quite an essential matter in so cold a climate as that of Chicago. The floor is composed of asphalt, laid with an inclination to the centre of the room, where a catch basin is built, connecting with the sewer, and having a metal strainer on top to catch matter that might stop up the sewer. The walls were all coated with hot asphalt for a height of six feet. This room is 45' deep by 14' 6" in depth. In the rear of the wash room is located a brick oil room, 9' X 14', where all oils used about the building are stored.

Adjacent to the oil room is located the elevator, with platform 28' 3" X 7' 8". It is worked by hand.

Steps near the elevator lead to the second story, which is used to stow one set of cars, either open or close, depending upon the weather. It contains the same number of tracks as down stairs.

The total capacity of this building is eighty cars.

The specifications for mason and carpenter work vary so little from those of the stable, that they are not repeated.

There were 365 cubic yards of excavations; 480 sq. ft. of dimension stone; 4,600 cubic feet of rubble; 387 m.

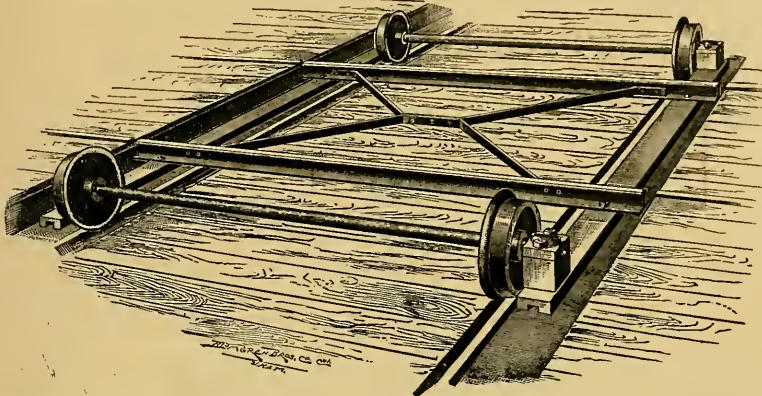

FIG. 61.

Swing bars	72	"	2 X 10,	5 1/2
Swing bars	72	"	2 X 8,	9
Door sills	16	"	4 X 16,	7 1/2
Door sill	2	"	4 X 16,	14
Door sills	2	"	4 X 16,	10

MILL WORK.

15 sash doors	3 1/2" double thick	7' 3" X 10'	8' Plan E.
3 doors	2 1/2" "	4' 3" X 8' 0"	Plan G.
5 doors	2 1/2" "	4' 0" X 8' 0"	Plan G.
1 sash door	3 1/2" "	10' 0" X 12' 0"	Plan C.
			In one part.
1 sash door	3 1/2" "	10' 0" X 12' 0"	Plan D.
1 sash door	3 1/2" "	10' 3" X 12' 6"	Plan K.
			In one part.
3 doors and frames with transom		2' 10" X 8'	Plan B.
7 doors and frames		2' 10" X 7'	
2 sash doors 3 1/2" double thick		12' 6" X 14 1/4"	Plan M.
			In one part, segment head.
17 window frames and sash,	32 lights	9" X 14"	
			Segment head, square back.
50 window frames and sash,	16 lights	9" X 14"	
			Segment head, square back.
2 mullein frames and sash,	32 lights	9" X 14"	
			Segment head, square back.

BILL OF IRON.

3300 partition rods, 5/8" X 30"; 14 ventilator grates, 15" X 24"; 288 pries gutter covers, 6" X 56"; 72 sets swing

brick; 93 window sills; 1 door sill; 30 bond stones; 532 lin. ft. of coping, in mason contract.

The following is the bill of lumber:

		In.	In.	Ft.	In.
First floor sleepers	720 pcs.	4	4	14	0
First floor posts	22 "	10	10	12	0
First floor posts	7 "	10	14	12	0
First floor corbels	22 "	12	14	4	0
First floor corbels	7 "	12	14	12	0
First floor braces	14 pcs.	8	10	6	0

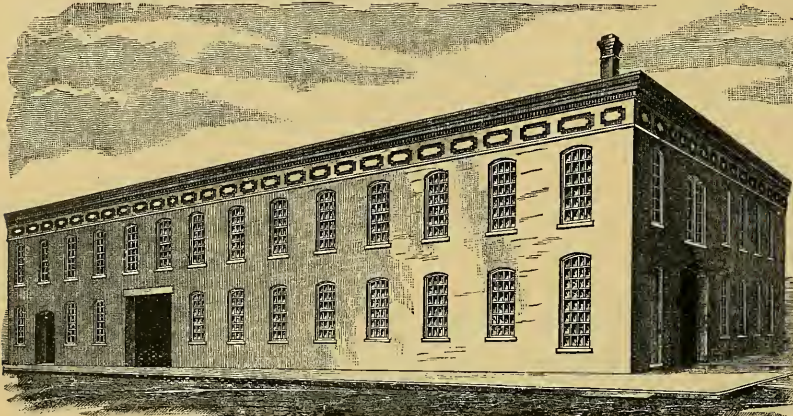

FIG. 52.

Second floor girders	56 pcs.	6	14	16	0
Second floor girders	8 "	6	16	30	0
Second floor joists	432 "	3	12	20	0
Second floor joists	144 "	3	12	14	0
Second floor posts	14 "	8	8	12	0
Second floor posts	8 "	8	8	12	0
Second floor posts	5 "	10	12	12	0
Second floor posts	2 pcs.	10	12	14	
Second floor corbels	22 pcs.	12	14	4	
Second floor corbels	7 pcs.	12	14	12	
Roof, girders	56 pcs.	6	14	16	
Roof, girders	8 pcs.	6	16	30	
Roof, joists	570 pcs.	2	12	20	
Roof, joists	190 pcs.	2	12	16	
Transfer table	6 pcs.	6	12	20	
Transfer table	6 pcs.	6	12	14	
Common plank	1	16	27,000	ft. bm.	
Dressed and matched	2	6	16	35,000	ft. bm.
Com. bds. surfaced 1 side	1	16	14,000	ft. bm.	
Partitions, s'faced 2 sides	84	pcs.	2	12	14
Wainscoting	1	4	12	100	ft. bm.
Lintels	8	pcs.	4	8	5
Lintels	35	"	1	8	16
Cord Ties	28	"	2	14	12
Bridging			1	1/2	3
Wall plates, etc.	600	"	2	4	16

MILL. WORK.  
90 window frames and 1 3/4 sashes, 24 lights 9" x 14" segment head, square back.

1 mullion frame and 1 3/4 sashes, 48 lights 9" x 14" segment head, square back.

		Ft.	In.	Ft.	In.
1 sash door, 3 1/2" D thick, in 2 parts, plan K	10	3	12	6	
1 " " " " " 2 " " " P	12	3	13	1	
1 " " " " " 2 " " " M	14	3	12	0	
2 " " " " " 1 " " " E	7	3	10	8	

1 sash door, 3 1/2" D thick, in 2 parts, 18 lights... 10 0 x 12 6

1 Panel door and frame with transom... 3 0 x 7 6

2 Panel door and frame, with transom... 2 10 x 8 6

24 Closet doors.

BILL OF IRON WORK.

400 medium bolts, 1/2" x 16", thread 2"; 800 cast iron washers, 3" diameter; 368 window weights, 14 lbs. each; 4,760 lin. ft. track iron, 1/2" x 1 3/4".

This iron had holes, countersunk each 1/16", and was screwed in top of the floor.

The following is a bill of hardware for both buildings: 3 doz. upright

pulleys; 44 double hanks sash cord; 3 doz. barn door pulls; 11 pair 4" x 4" butts; 11 mortice locks; 6 pair heavy 12" strap hinges; 4 pair heavy 10" strap hinges 1 doz. large size sash rollers; 24 Yale locks, with two keys each; 24 pair 2" x 2" butts; 5 doz. sash fasteners. Wrought iron sheaves and track, 17 pair for 7 ft. door; 3 pair for 14 ft. door; 4 pair for 10 ft. door; 8 pair for 4 ft. door. one

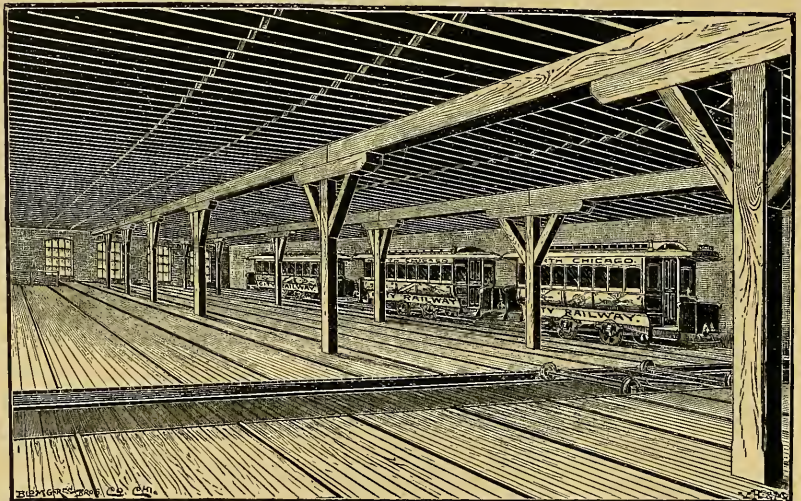

FIG. 63.

2-horse power; one hay cutter; one 6-ton platform scales; one hand elevator.

The total cost of both buildings was \$42,936.99, which includes everything except the ground.



The first story walls of both buildings are 16" thick, second story, 12" thick, and both have four ply gravel roofs guaranteed for five years.

Fig. 62 is an exterior view, and Fig. 63 an interior view of this car house.

(To be continued.)

### Caldwell's Concrete Mixer.

The rapidity and solidity of the work of constructing the cable tube and track of the North Chicago cable railway, especially the all night and day work on the South Side extension thereof, has surprised many who have noticed its progress, and induced favorable newspaper comments. It brings to mind the alarming anticipations excited by the opening of the streets for the construction of the South Side cable railway some six years ago; it was feared the work would be slow and tedious, and that business along State street would thereby be seriously injured. And at first, the work did not progress very rapidly; several appliances for

known by other methods; 4th. It is by far the cheapest machine ever invented, considering its durability and wonderful capacity. The North Chicago Street RR. Co. speak in the highest terms of its great benefits. In fact, the dailies of the city have taken occasion unsolicited to make special comment on the rapidity and efficiency of its work.

The Chicago City Ry. Co. was the first to use the Caldwell Concrete Mixer for the construction of cable street railways. But the Caldwell mixer was well known, and used to good purpose, during the United States civil war years ago. The inventor (Mr. Caldwell) was an officer on the winning side, and now numbers among his patrons many esteemed war comrades. Gen. W. H. H. Benyard used his mixer in some of his government work. It was also used by Gen. Wm. Sooy Smith in building a bridge at Yazoo Pass., Miss., and on his great work at Havre de Grace, Md.; by Gen. Fitzsimmons in several of his engineering works, such as Rush street bridge and other structures. The city engineer of Milwaukee (Mr. Benzenburg) used it in repairing the break in their reservoir; also the Lincoln Park Commission in building the sea wall to protect the drive on the

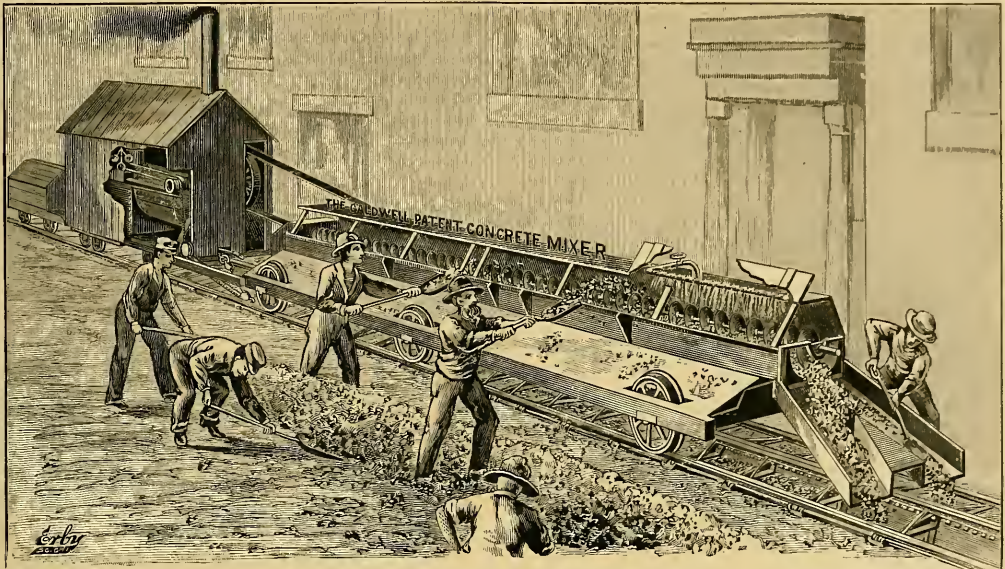

stirring and mixing the concrete used did not operate satisfactorily—until the Caldwell mixer was tried. This answered the purpose well. And it is this same apparatus that enables the construction of the North Chicago cable road to proceed so rapidly.

A description of Caldwell's Concrete Mixer cannot fail, therefore, to be interesting. It is the invention of Mr. Henry W. Caldwell (131 and 133 W. Washington street, Chicago), a well-known citizen of the Garden City, who has gained a national reputation as the inventor of the Caldwell Conveyor. But in no sphere of usefulness has his talent been more appreciated than in this patent concrete mixer. It is simple in its construction and is well understood by a glance at the accompanying cut. The principal advantages gained by this mixer are: 1st. Its great capacity, enabling the work to be pushed at the rate of 600 to 900 feet per day of 10 hours; 2nd. It so thoroughly mixes the material that a better class of concrete is made, with less cement; 3d. The cement is dusted over every particle of stone and sand so perfectly that when the water is admitted, which is only done at the last length or section, the mass can be handled and put in place, and will not set or form its bond, until tamped, which action causes the loaded globules to spread and unite the several particles more firmly than ever

Lake Front. Mr. C. B. Farwell used it in constructing the walls of his large block, corner of Jackson and Market streets, the walls of which are of concrete all mixed by one single Caldwell mixer. It is, therefore, not a new and untried invention. And it has been very successfully used in the construction of cable street railways, in Chicago (as already stated), Cincinnati, Philadelphia, etc. The steam railroads throughout the country are also beginning to use it for constructing bridges, culverts and foundations. And Mr. Caldwell may well feel proud of the success of his valuable invention.

"SHALL I be put off if I smoke here?" asked a passenger on the front platform of a Metropolitan car last night. "No, sir; but I shall lose \$2," was the answer. "It is the rule of the company that the driver or conductor who permits smoking on his car is suspended from one to three days." Further conversation developed the fact that in the experience of the company's employees most men are restrained from violating the company's rule in regard to smoking by a mere mention of the fact that the penalty will be visited on the head of the driver or conductor.—*Boston Advertiser.*



**Grand Success of Street Railways.**

That street railways—especially in the United States—pay well is evident; although occasionally about one in a thousand (and a small one at that) proves a failure. This fact gains striking prominence when street railway properties and privileges are publicly put up for sale, such as the sale of \$500,000 worth of the Market Street Railway bonds in San Francisco, the end of April, and the sale of the franchises of a couple of street railways in New York, May 31st.

“HOW TO MAKE SIX MILLIONS”

is the caption of an article on this “new source of revenue” in the San Francisco *Call*, April 27th, which says:

“The recent sale, in two parcels, of \$500,000 six per cent. bonds of the Market Street Railroad at \$130, affords a suitable opportunity for a few observations on that enterprise, and for the profits which have accrued to its builders. When, some four or five years ago, the owners of the horse-car line on Market street, who were none other than the stockholders of the Pacific Improvement Company, resolved to convert the horse-car line into a cable road, they were able to figure very near how much business the new line could count upon and how much of the receipts would be profit. They figured that the line would yield not less than \$180,000 a year net profit over and above all expenses. This represented, at six per cent., the interest on three millions, and accordingly the Market street company authorized an issue of \$3,000,000 of six per cent. bonds. Mr. Flood agreed to take all this issue, or so much thereof as the company might need from time to time, at par. It was discovered as the line drew near completion, that it would not cost over \$2,000,000 to build the roads and equip them, and accordingly that amount was handed to Mr. Flood in exchange for money; the other million remained in the hands of the Pacific Improvement Company, or was divided among its stockholders by way of a dividend.

“The road has now been in operation three or four years, and the gross income is about a million. The income account is about as follows:

Gross income .....		\$1,000,000
Working expenses .....	\$500,000	
Interest on bonds .....	180,000	
Balance to credit, profit and net .....	320,000	
		1,000,000

“The promoters of the enterprise had foreseen that it might be so unfortunate as to earn more than the \$180,000 necessary to meet the interest on the bonds, and they had provided against the accident. When the company was organized, they authorized an issue of \$5,000,000 of stock, which they divided up among themselves. Of course, when the lines were only earning interest on the bonds, the stock was valueless. But last year, when it earned a surplus, over its interest, of \$320,000, considerably over 6 per cent. on five millions, dividends were begun on the stock at the rate of 3 per cent. semi-annually. Inquiry has elicited the fact that the income of the lines is increasing at the rate of 17½ per cent. per annum. Under these circumstances par is bid for the stock, and we have no doubt the stockholders in the Pacific Improvement Company could sell out their entire five millions at that figure.

“Thus, out of this one little enterprise, comprising less than sixteen miles of city railroad, the syndicate has realized six millions of dollars clear profit in less than four years. In comparison with this, the gains of stock gamblers and wheat gamblers are trifling and illusory, and it will be observed that the operators never ran the risk of losing a dollar.”

This safe and paying enterprise has been commented upon by financial writers generally, and by the organs of the labor party in particular. One of the latter, the San Francisco *Star*, gives space for the entire article of the *Call*, quoted above, and then admonishes the reader to “paste this brief article in your hat, or better still, fix it firmly in your head, for it is worth knowing and remembering: That the property occupied by these capitalists is public property, every foot of it, and the franchise under which it is claimed and used was obtained, so far as the records show, as a free

gift. Note farther, that no other citizen or combination of citizens is eligible to the same privilege on the same routes, so that it is purely and simply a monopoly, and thus the case stands. The city of San Francisco has given the exclusive use of sixteen miles of the public property to certain individuals for nothing. In four years the bonds which represent the money invested in construction have appreciated 150 per cent., and the gross annual income is fully 50 per cent. of the investment, and increasing at the rate of 17½ per cent. per annum. We will admit that the service is well managed, that the comfort of the public is cared for, that the employees are well treated; but the point to be borne in mind is that the franchise is valuable because it is a public necessity, because it is built on public property, and because it is the only available means of communication between distant points. The land and labor party would have this public function performed by the public, for the benefit of the public, and every increase of patronage would redound to the private benefit of the citizen; and instead of producing these enormous annual grants of money by taxation, for it is practically this, to the advantage of a few citizens, would reduce the fare to two or three tickets for five cents, and so let the entire community partake in the result of community growth and prosperity. Then look at the immense community advantage of the increased taxable valuation of the lands which are thus made available for residence and business purposes, all of which would swell the common profit and be of practical benefit to every man, woman and child within our borders.”

The immense amount of money made in so short a time without risking a dollar (so to speak) is perhaps without a parallel, and is an evidence of the amazing profits possible from brains backed by unlimited capital. And it was natural, therefore, that considerable interest was aroused in New York city the 31st of May by the sale at public auction of franchises for the construction, operation and maintenance of two street railways. The sale was the first under the provisions of the Cantor law, recently passed by the legislature, the object of which is to secure for the city some compensation for the valuable franchises which it has at its disposal. The franchises sold are for street railways respectively known as those of the Twenty-eighth and Twenty-fifth streets and the Fulton and Cortland Street Ferry Railroad Companies. The bidding was spirited, and reached figures far beyond expectation. The law requires that the city must not receive less than 3 per cent. of the gross receipts of the road for the first five years of its operation, and thereafter 5 per cent.; but as a result of this sale the companies must pay respectively to the city 26 2-10 and 35 per cent. of their gross receipts, in addition to the 3 and 5 per cent. presented as a condition of the sale for all time to come. During the first five years they pay respectively 29 2-10 and 38 per cent. of their gross receipts, and thereafter 31 2-10 and 40 per cent. The law, in addition, requires that the company receiving the contract must agree to keep the pavements between the rails in proper repair, and clear of snow, dirt, etc., and submit to the numerous city ordinances that apply to street railways. The Bentley-Knight electric system is to be used on the last named railway, which will cost about \$250,000.

FROM the Chicago Wood Finishing Co., we have the following: The Rough Stuff and Wood Fillers manufactured by the Chicago Wood Finishing Co. have been subjected to the severest tests on street railway cars for the past eight years; and in no instance has their Rough Stuff cracked, sealed or blistered, nor has their Wood Filler shrunk in the pores of the wood. There are no goods manufactured which can show a better record.

ALWAYS give the conductor the extra change. Mistakes in making change are very common in crowded cars, and not seldom in the passenger's favor.

“MORE cars” is the cry at Straitsville, Ohio.



**Electric Railways.**

There are eleven electric railways in operation in the United States, covering an aggregate of 39 miles, and numerous other electric roads are either in course of construction or projected by newly-formed companies. The Daft system of electric railway propulsion is in the hands of two powerful companies—the Daft Electric Light Co., and the Safety Electric Railway and Power Co.—and both of them mean business in good earnest. The Daft system is giving very great satisfaction at Orange, N. J., Los Angeles, Cal., Baltimore, Md., etc. The Van Depoele electric railway system is in very successful operation at Scranton, Pa., Appleton, Wis., Montgomery, Ala., Detroit, Mich., Windsor, Ont., Port Huron, Mich., etc; and they very reasonably lay great stress on that fact. The Bentley-Knight Electric Railway Co. have reached great prominence in securing the contract for the Fulton Street Electric Railway, New York; and the Sprague Electric Railway and Motor Co. are making extensive preparations for equipping a large number of electric railways. Other street railway electricians follow in the wake of these prominent leaders.

There are 11 electric railways in operation in Europe also, the longest being the one at the Giant's Causeway, commonly called the Portrush line, six miles. The rest aggregate 14½ miles. And other electric roads are ready for operation, etc.

At the New York meeting of the American Institute of Electrical Engineers, May 18, last past, "a few comparative statistics of electric railways" were given by Mr. T. C. Martin, one of the editors of *The Electrical World*, from which the following is a condensed abstract :

**ELECTRIC RAILWAYS IN AMERICA, APRIL, 1887.**

Place, Date of Opening and Length.	Mot'rs	Conductors.
†Baltimore, Md., 1885, 2 miles.	6	Third rail and overhead wire.
†Los Angeles, Cal., 1887, 3 miles.†	8	Single & double overhead wire.
†Port Huron, Mich., 1885-6, 4 miles	8	Single overhead conductor.
†Windsor, Can., 1885, nearly 2 mls	2	Single overhead conductor.
†Highland Park, Detroit, Mich., 1886, 3½ miles.	2	Sunken central rail.
†Dix Road, Detroit, Mich., 1886, 1¼ miles	4	Double overhead conductor.
†Appleton, Wis., 1886, 4½ miles.†	8	Double overhead wire.
†Scranton, Pa., 1886, 3¼ miles	3	Overhead wire.
†Denver, Col., 1886, 3½ miles.†	7	Conduit for series system.
†Montgomery, Ala., 1885-86, 11 miles.†	18	Overhead conductor.
Kansas City	No sp	Specific details received.
Orange, N. J., 1887, ½ mile built	1	Overhead conductor.
Boston, Mass. (sugar refinery). 1887, short track.	--	Overhead conductor.

†Extending line or increasing rolling stock.  
 †Single and double tracks.

**New Roads.**—Electric railways are now in course of construction, or under contract, at Pittsburgh (3 roads); Los Angeles; Binghamton, N. Y., 4½ miles, 8 motor cars; Lima, O., 3 miles, 6 cars; San Diego, Cal., 9 miles, four 40 h. p. motor cars; Ansonia, Conn., 3½ miles (water power); New York City (for Fulton street); St. Joseph, Mo., 20 cars; Mansfield, O.; Ithaca, N. Y.; Harrisburg, Pa.; Woonsocket, R. I.; Richmond, Va., 11 miles, 40 cars.

Companies have been formed or steps taken to build and operate electric roads at Flushing, L. I. (2); Lincoln, Neb.; Brookline, Mass. (2); East Cambridge, Mass.; Newton, Mass.; Boston, Mass.; Asbury Park, N. J.; Pelham Park, N. Y.; New Brunswick, N. J.; Plainfield, N. J.; Bayonne, N. J.; Worcester, Mass.; Scranton, Pa.; Carbondale, Pa.; Philadelphia, Pa.; Reading, Pa.; Bangor, Me.; Biddeford, Me.; Westfield, Mass.; Chicopee, Mass.; Muncie, Ind.; Gratiot, Mich.; Tiffin, O.; Cincinnati, O.; Brooklyn, N. Y.; Coney Island, N. Y.; Rockaway, N. Y.; Winston, N. C.; Jacksonville, Fla.; Pensacola, Fla.; Birmingham, Ala.; Sel-

ma, Ala.; Atlanta, Ga.; Fort Smith, Ark.; Wichita, Kan.; San Francisco; San Jose, Cal.; Newton, Kan.

**ELECTRIC RAILWAYS IN EUROPE, APRIL, 1887.**

Place, Date of Opening and Length.	Mot'rs	Conductors.
Lichterfelde, 1887, 1½ miles.	2	All rail.
Brighton, 1883, 1 mile.	2	All rail.
Moedling-Hinterbruehl, 1884, 2.8 miles	12	Overhead slotted tubes.
Frankfort-Offenbach, 1884, 4 1/4 miles (double track)	14	Overhead slotted tubes.
Zaukerode (mine), 1882, 790 yards	--	Overhead inverted I rail.
Hohenzollern (mine), 1884, 820 yards	--	Overhead inverted I rail.
Portrush, 1883, 6 miles.	4	Third rail.
Besspool, 1885, 3 miles.	8	Third rail.
Blackpool, 1884, 2 miles.	10	Conduit.
Brussels, 1887	5	Operated by storage batteries.
Hamburg, 1886.	2	Operated by storage batteries.

**New Roads.**—A special charter has been granted by the Austrian government for a road in the Austrian Alps, to cost about \$350,000, and to be 15 miles in length. A road is being built in the great salt mines at Stassfurt, Germany. The North Metropolitan Tramway Company in London has several motors now ready for use with storage batteries, on its line, awaiting powers from Parliament.

**Cars, Stables and Horses Burnt.**

About 1:30 o'clock in the morning of May 27, a terrible fire burned the stables, car house and their contents, including 1,200 horses of the Central Park, North and East River RR. Co., commonly called the Belt Line, on Tenth avenue, between Fifty-third and Fifty-fourth streets, New York. The tenement houses connected therewith, and those on the block on the opposite side of Tenth avenue, together with adjoining buildings on all sides, were also consumed. The total loss is estimated at \$1,325,000. The fire raged till daybreak, but was under control. A number of policemen and firemen were overcome by the heat and sent to the Roosevelt Hospital. The sun rose upon a scene of desolation. The bodies of 1,200 horses were roasting in the ruins of the stable. More than one hundred families, mostly very poor people, had been rendered homeless. Men, women and children wandered all morning aimlessly over the ruins of their wrecked homes, bereft of their all and bewildered at the sudden and crushing blow.

The loss has been figured up as follows: Railroad stables, \$550,000; 1,200 horses, \$250,000; 175 cars, \$180,000; harness, \$75,000; feed, \$25,000; total, \$1,080,000. Only ten horses and two cars were saved. The insurance is \$310,000, divided among some 150 companies.

The executive committee of the company held a meeting on the morning of May 28, including President Scribner; and they unanimously resolved to substitute the cable, electrical motor or some other power in place of horses. A large force of men were put to work clearing away the ruins of the great fire, and temporary sheds are erected to accommodate the cars and horses that the company will use until it gets its new system in operation. The other railroads have sent a number of cars. The greatest difficulty in starting the line again has been in securing horses. Only a few hundreds have been procured. Orders for new cars have already been placed in Long Island, Philadelphia and St. Louis.

About the same time there was a conflagration at the stables of the Cincinnati Street Ry. Co., near the site of the old Brighton House, Cincinnati, Ohio. The employees saved the horses by turning them out (and they stampeded frantically along the central streets of the city), and also most of the harness and all the cars. Only about half the stable was burnt.

### Elevated Railways Legislation.

"Elevated Railroads" is the subject of a bill submitted by Gen. Butler to the Street Railways Committee of the Massachusetts Legislature, April 27th, to amend the Meigs elevated railway Act of 1884, and to be applicable to all elevated railways. Gen. Butler explained that he had nothing to do with the Moulton system of elevated railways, and knew nothing of it except that he had "a very strong opinion" as to the interference of the Moulton patents with the Meigs invention. In complaining of the restrictions in the Meigs Act he said that Sec. 2 declares that the amount of the capital stock of the company shall not be less than \$100,000 for each mile of said road. "Now, we don't want a capital stock of that amount for each mile of our road," said the general, "for we think we can build and equip our road for \$75,000 a mile, and we don't know why there should be a burden upon us of a capital stock of \$100,000 a mile. That has been put in to discourage, and it has discouraged a great many men. There was another restriction put in that section, from which, however, we do not ask any relief, which is that not less than 10 per cent. of the capital stock shall be paid in in cash before the stock shall be issued. We can take that burden. Also that the whole capital stock shall be paid in in cash before the construction of the road shall be commenced. We were asking for a road of about seven miles from Cambridge to Boston, and a provision was put in deliberately, that we should not strike a stroke until we had paid in a capital stock of \$700,000. Not only that, but they put in, you shall build a mile, before you shall ask for a location, and we could not build the mile until we had paid in \$700,000. The respect I have for this presence (the committee) prevents my using words of characterization."

Gen. Butler proceeded to deal with other unreasonable restrictions, in other sections, and summed up saying:

#### WHAT IS WANTED.

"We desire that these sections, when amended, shall be made as a part of the general law under which the two previous charters shall be governed, by which they shall be governed, and that all legislation hereafter shall not burden elevated railways with these restrictions, and that this shall be a guide, after an elevated railway system has been sufficiently tried, and we have been allowed to organize elevated railroads under any system, as we are now allowed to organize surface railroads. Then that these restrictions as in these sections, shall be the general law under which they shall be organized, and that would be this: First, under the first section that the road shall be allowed to go where the mayor and aldermen in cities adjudge the public convenience and the utility of the road demand. Second, that there shall be no restrictions as to how much per mile there shall be of capital stock issued, but only that there must be \$100,000 at least issued, that the company must be organized for \$100,000, and 10 per cent. be paid in before anything can be done, so that everybody can be made safe. And lastly, that the most burdensome and unjust provision as to a lien shall be stricken out, and the other provisions as to security be left in. Then we can build our road and other people can build theirs, and commercial value will establish which is the best system."

### The Connelly Motor.

"Noted electricians in all parts of the world have been engaged during the past fifteen years in efforts to perfect an electric motor, but so far without practical success." So says the New York *Daily Graphic* of April 5, as an introduction to its description of the Connelly Motor; and after repeating its statement that "up to the present time" all the electric motor systems "have labored under one great and common disadvantage, *i. e.*, excessive cost of production and loss in transmission of electricity," it declares that "the 'Idea Motor' must be perfectly independent, complete within itself. It must generate its own power, it must travel on any track! It must be light, compact and perfectly safe, without fire, dust or odors; it must be practically noiseless

and capable of being operated by an unskilled driver. Messrs. Connelly, of 177 Broadway, New York, manufacturers of gas machinery, concluded that such a motor could be constructed to use gas as the motive force or agent, and boldly undertook the task of overcoming the many difficulties encountered in applying an engine of any character to a street car. \* \* \* In this motor the engine is kept in constant motion, at an average speed of 300 revolutions per minute, and the fly-wheel driven at a speed of 1,000 revolutions per minute. A new and ingenious device is employed to reduce the friction, and performs a very important service, permitting the use of a very small fly-wheel in proportion to the power exerted, driven at an extra high speed, with no loss of power or increased friction." The most important feature of the invention is the "power storage" device, which "doubles the power of the engine for a few seconds, or long enough to overcome the inertia of the car when starting. \* \* \* The engine being driven at a uniform speed at all times, there is provided an intermediate shaft with three friction clutch pulleys of different diameters, corresponding with diameters of fixed pulleys on engine shaft. Three hand levers connecting with clutch pulleys extend to the side of the driver, who can obtain desired speed by merely pressing down the proper lever. \* \* \* The cost of operating the Connelly motors would not exceed \$2 per day, covering fuel, lubrication, care, repairs and royalty. The cost of equipping a road with these motors is less than one-fifth the cost of any cable system, and about half the cost of any electric system."

We have not yet had an opportunity of seeing this "Ideal Motor" at work.

### Sanding Tracks.

At the Boston Highlands we recently observed a cart loaded with sand moving slowly along at the side of the horse railroad track, having a driver and a laborer employed in placing sand upon the track.

A reflection was suggested that one cart, one horse, and two men, one load of sand, time and labor inclusive, were rather costly when compared with some of the sand sprinkling devices now being attached to a large number of street railway cars. But this was by no means a singular instance. On a curved, steep, down grade on what is known as Cornhill, Boston, the same operation with the same means may be frequently seen. For all this, the mechanical car track sand sprinklers will, in course of time, tell their own story, and, accordingly, as they prove their efficiency, economy and usefulness, they will be recognized by railroad companies and get into more general use.

There is no season of the year when sanding the tracks is unseasonable, at certain points on different roads.

The sand used on locomotives has to be very fine and dry. Hence, placing the covered metallic sand box on top of or close to the boiler is necessary in order to keep the sand thoroughly dry. The run of this fine dry sand is regulated at will by the engineer. The pipe through which it runs is a rigid, metallic one, the mouth being directly over the centre of the rail. Its diameter is, comparatively, small, say, from one to one and a quarter inches.

Such an appliance is altogether unsuitable for street cars where damp sand, gravel, salt or common earth should be available. These ingredients will, of course, clog in tubes of small diameter.

### Will the Wheel Turn?

A new kind of motor has considerably excited the citizens of Donaldsonville, La. A Mr. Webster has a wheel which turns itself, it is said. A stock company has been formed, says the *Picayune* (May 31), and the papers have been sent to Washington; a caveat is filed, and the model is now being made at one of the leading foundries in New Orleans. The model consists of a brass wheel five inches in diameter and two inches in thickness, with a serrated margin. It will be mounted upon a pinion resting between upright pieces, all to be placed within a glass case. The total cost of the model is \$110. Mr. Webster claims that



his wheel will revolutionize machinery; that it can run any machine, from the slow and regular movement of a clock to the heavy pounding of a rolling mill. The wheel, if a success, creates its own power at no cost, and covers all the requirements of perpetual motion. The company is composed of the leading professional and business men of Donaldsonville, and all the stock is taken. The question is "Will the wheel turn?" Nous verrons.

### Mechanical Traction on Street Railroads.

NOTES ON EXPERIMENTS IN EUROPE, 1870 to 1880.

BY E. E. RUSSEL TRATMAN, JR. AM. SOC. C. E.

(Concluded.)

The Scott-Moncrieff car and compressed air engine (combined) weighed from 11,200 pounds to 15,120 pounds (the first ones being 17,920 pounds) empty, could be driven from either end and could be stopped in their own length. There were 6 reservoirs, weighing 784 pounds each=4,704, and 40 passengers, 140 to 168 pounds each=6,160 pounds, making a total, when loaded, of about 25,000 pounds. From 400 to 500 cubic yards of air, at atmospheric pressure, were consumed per mile, and a compressing engine of 150 H. P., costing about \$5,000, was stated to be sufficient to maintain a daily service of 1000 miles. Sir Joseph Whitworth thought the working pressure very much below what could be attained; but Mr. Scott-Moncrieff thought that for practical purposes there would be a loss in going beyond the 300 pound pressure; the pressure per square inch in the cylinders was 2.25 pounds. It was estimated that 40 per cent. of the power exercised by the compressing engine was available for driving the car. A speed of 25 miles per hour was attained, and a grade of 1 in 20 surmounted. Although a combined car, it could haul another car on occasion. The cost of motive power at Glasgow was 1 cent per mile; including engineer, lighting, cleaning, and all expenses except the conductor and maintenance of track, the cost was about 6 or 8 cents per mile, the gross working expenses, including royalty, being about 10 cents per mile. Later, engines ran 4 and 6 miles without recharging, the pumping stations being located at intervals of 3 and 5 miles respectively for a 4 and 6 mile car. The cost of each car was approximated at \$3,000.

**Remarks.** Mr. Rowan, whose combined steam car system has been brought into considerable use, and received a gold medal at the recent competition at Antwerp, stated in a report in 1877 that, for the efficient working of a line having heavy grades, an engine of from 15 to 20 H. P. would be required, and that such an engine could be made to occupy not more than 150 cubic feet, and to weigh not more than 5,600 pounds, without requiring a higher pressure of steam than 150 pounds per square inch. Mr. Haddan, M. I. C. E., on the other hand, was in favor of a detached engine, because it is desirable to have one engineer to each engine in order to know just who is responsible. As the engineer's time is 10 hours and the car runs 17 hours, 30 to 40 per cent. more rolling stock would be required for the "combined" car; for this reason detached engines were used in Paris, each with a personal staff consisting of engineer, fireman, and cleaners, in preference to "combined" cars, as the latter would have required a double staff or relief, which was found to be impracticable. Mr. Stephenson, chief engineer of the Wantage line, stated (1878) that the advantage of the Grantham "combined" car was, that the passenger load gave increased adhesive power to the driving wheels, while there was no butting of cars when stopping. Major General Hutchinson, inspecting officer for the Board of Trade (England), in his evidence before a special Parliamentary committee in 1878, said that he thought the board should be authorized—before licensing the locomotives—to require a certificate that the boiler had been put to an adequate test, viz: a pressure of about 300 pounds per square inch, the working limit not exceeding a certain definite proportion of the test pressure. He expressed himself strongly in favor of automatic governors, out of the engineer's control, and also advocated the use of speed indicators or recorders.

Mr. Rowan, in the report above alluded to, gave the following comparison between cars drawn by horses and by engines and steam cars on his own system:

	Car drawn by horses.	Car drawn by separate engine.	Steam car.
Number of passengers.....	40	40	60
Number of attendants.....	2	2	2
Length of street occupied.....	35 feet	35 feet	32 feet
Weight, fully loaded.....	12,320 lbs.	21,280 lbs.	21,880 lbs.
Dead weight, without passengers.....	5,600 "	11,560 "	11,290 "
Greatest weight per wheel with full load.....	3,080 "	3,080 "	3,960 "
Greatest weight per wheel without load.....	1,100 "	3,240 "	2,240 "
Greatest weight on drivers with full load.....	3,960 "	3,960 "	13,440 "
Greatest weight on drivers without load.....	4,960 "	4,960 "	8,960 "
Dead weight per passenger with full load.....	140 "	261 "	167 "
Horse power for haulage.....	2 H. P.	18 H. P.	18 H. P.
Steepest grade on which the car can work for long distances.....	1.25 per cent.	2.50 per cent.	5.00 per cent.

In April, 1878, the following list of steam locomotives, then in use on tramways, was given by Mr. Cham. B. King, C.E.: Swansea, 3; Vale of Clyde, 8; Wantage, 3; Guernsey, 1; New Zealand, 5; Barcelona, 5; Bilbao, 2; Cassel, 5; Cologne, 1; Lisbon, 1; Paris, 37; The Hague, 1. Total 72.

While the advantages of steam power were very generally recognized, it was thought that where one-horse (bottail) cars could accommodate the traffic, there would be no economy in using steam.

The following table shows the change in freight rates from the depot to town, effected by the Wantage tramway:

FREIGHT.	Rate before.		Rate after.	
	Wholesale	Retail		
Coal.....	54 cents	24 cents		
Stone and lumber.....	64 "	60 "		
Road stone.....		30 "		
Merchandise.....	\$1.08	72 "		
Hardware.....	\$1.08	81 "		

In 1878 15,000 packages were carried on this line.

In London the narrowest width of streets in which a street railroad was laid were, in 1877: (double line) 16 feet 10 inches, with 1 foot 3 inches and 2 feet 3 inches, respectively, between the curbs and the rail; and (single line) 25 feet 10 inches with distances of 10 feet 4 inches and 10 feet 6 inches between curbs and rails.

**North Metropolitan Tramway Company.**—Although not strictly pertinent to the subject, the following statistics of this extensive street railroad system operated by horse traction, are appended. In 1876 the cars ran 2,569,000 train miles over 30 miles of track, and carried 26,854,000 passengers. The 60-lb. iron rails were then being replaced with steel; the steepest grade was 1 in 40 except short pieces of 1 in 25 on canal bridge approaches. The cars were 24 feet long over platforms, with bodies 16 feet long and a capacity for 46 passengers, they weighed empty, from 5,600 to 6,160 pounds, and about 11,200 pounds loaded; they ran about 70 miles per day. Mr. Hopkins, the chief engineer, thought the track could safely carry a car weighing 26,880 pounds. The cost per mile for traction ranged from 12 to 14 cents per pair of horses, or including driver, about 16 cents; in 1878 the General Omnibus Company contracted to horse the cars for 13.5 cents per mile run. Mr. Hopkins estimated that steam traction would have cost 9 or 10 cents per mile, a saving of about 4 cents, which at the above mileage would, in the year instanced, have resulted in a saving of about \$3,500 per mile. The total expenses were about 20 or 21 cents per mile, of which the motive power was 13.5 cents. The contract with the General Omnibus Company provided that each pair of horses should not work less than 14 nor more than 16 miles per day, so that at the mean of 15 miles 5 pair of horses would be required for each car; the omnibus company objected to awnings over the outside seats, on the ground that it increased the load and strain on the horses. The average life of a street car horse was estimated at 4 years; they cost about \$200, and if worked for 4 years were expected to fetch from \$40 to \$50; this was about the same average life as that of the stage horses.

### Street Railways and Boston Common.

There always has been, and there is now, a strong feeling among the citizens of Boston relative to any plan that would cause an encroachment upon the domain known as the Boston Common and the adjoining Public Gardens. For a great many years the former has served as a delightful public resort and an appropriate location for national, state and city commemorative celebrations. It is historical. It is carefully tended and appears more inviting and beautiful every year. To have a horse railroad on any part of the now cultivated and attractive grounds, however desirable it may seem for passenger transportation from the Boston and Providence Railroad, or for connections with the present street railways at the west end of the city, would most certainly mar the beauty of this part of the city and detract from the pleasing general appearance of the grounds.

It has been claimed by some that old land-marks, and historical buildings and edifices are now retained in Boston from mere sentiment. Such buildings as the "Old State House" and the "Old South Church," so far as architecture goes, are no ornaments to the city, and are mainly devoted to the exhibition of revolutionary and historical relics. They take up valuable room which could be occupied by fine buildings for public or commercial purposes or removed entirely to gain more space for the now uncomfortable and crowded thoroughfares. This is a subject, however, which belongs solely to Boston citizens and to Boston interests, and the question as to which is best—the ancient or modern—remains where it should remain for solution. But when a plan is projected to carry railways across attractive public grounds, hitherto preserved for public use and healthful recreation, we can not bring in any recognition of the sentiment argument. The old land-mark buildings in the heart of a city should not be placed on the same level, in estimation, importance and usefulness, with large areas of well laid out grounds for public recreation, as well as for city ornamentation and improvement. There is a pressing demand for more room, greater business facilities, quicker transit in Boston. The pressure at the centre of "The Hub" is being felt by all classes, and naturally enough this pressure is indicated by the gradual movement of business into a quarter hitherto occupied by the residences of the older and wealthier families of Boston.

The plan of crossing the Common, or appropriating any part of its present area, has been disapproved; and the second proposition, to tunnel under it, has also been refused. One of the objections to the latter plan is that tunneling would interfere with and fatally injure the roots of many fine trees that are now at their best in growth, and size, and appearance.

The Common, therefore, is to be left intact, as will be seen from what follows.

On May 23 last past, the committee on street railways reported to the Senate the following bill, favorable to the West End Railway:

"An act to authorize the West End Street Railway Company and certain other street railway companies to lease and to purchase and to hold the property, rights and franchises of each other, and to unite and consolidate with each other and certain other street railway companies, and to locate and construct tunnels, and to establish and maintain the cable and electric systems of motive power and for other purposes. Be it enacted, etc.:

"Section 1. The West End Street Railway Company and each of the other street railway companies now authorized to run cars in or into the city of Boston, and each corporation formed by consolidation as herein provided, may unite and consolidate with any or all said companies and may purchase and hold the whole or any part of the property, rights and franchises of any or all of the same; and each of said companies may lease, sell, convey and assign to said West End Street Railway Company, or to any other of said companies now existing or hereafter formed by consolidation under this act, the whole or any part of its property, rights or franchises, and may unite and consolidate with said West End Street Railway Company, or any corporation formed by consolidation as aforesaid, or with any street

railway company now authorized to run cars in or into the city of Boston; but such leases, purchases, sales and consolidations shall be only upon such terms and conditions as shall be agreed upon in the first instance by the directors, and then by a majority in interest of the stockholders of each corporation, at meetings of the stockholders of each corporation called for that purpose, and approved by the board of railroad commissioners, and in every case of purchase by one corporation of the entire property, rights and franchises of another or others as aforesaid, the corporation purchasing shall have, hold, possess, exercise and enjoy all the locations, powers, privileges, rights, franchises, property and estates which, at the time of such purchase, shall be had, held, possessed or enjoyed by the corporation or corporations selling, or either or any of them, and shall be subject to all the duties, restrictions and liabilities to which they, or either or any of them, shall then be subject; and in every case of consolidation as aforesaid, the corporations uniting shall constitute a new corporation under such name as shall be agreed upon in the manner and at the meetings aforesaid; but the calling of the first meeting of said new corporation, and the management of its business until the election of officers, shall be provided for in its articles of consolidation; and every corporation formed by consolidation as aforesaid shall have, hold, possess, exercise and enjoy all the locations, powers, privileges, rights, franchises, property and estates which, at the time of such union, shall be had, held, possessed or enjoyed by the corporations uniting, or either or any of them, and shall be subject to all the duties, restrictions and liabilities to which they, or either or any of them, shall then be subject, and to all general laws then or thereafter in force relating to street railway companies, except as provided in this act.

\* \* \* \* \*

"Section 4. Said West End Street Railway Company, and any corporation formed by consolidation under this act, or authorized to run cars in or into the city of Boston, may, with the consent of the board of aldermen of the city, or the selectmen of the town in which such action is contemplated, establish and maintain the cable and electric systems of motive power, or either of them; and having first obtained permission from the board of aldermen of such city, or the selectmen of such town, and the railroad commissioners, may make such underground and surface alterations of the streets in which its tracks shall be located as may be necessary to establish and maintain such cable and electric systems of motive power, or either of them, excepting that in the city of Boston the consent of the fire commissioners shall be first obtained.

\* \* \* \* \*

"Section 7. No location shall be granted upon and no tunnel shall be constructed under Boston Common under this act."

President Whitney, of the West End Land Company, states in relation to the West End Land Bill, as passed: "Something must be done to remedy the present horse railroad evils, and if the present method can not accommodate the riding public, some other means must be provided, and hence tunneling the Common was decided upon as being the most feasible, for it would not injure the Common in any manner, and would benefit the thousands of people who desire to get to the business centre from Park Square. Still, if the Legislature does not care to grant us that privilege, we must look for some other remedy for the present evil. What we desire to do is to accommodate the public."

The citizens of Boston seem to speak their sentiments by some such expression as this: The West End Land Company can best accommodate the public by letting the Boston Common alone. Hands off!

NEW cars, recently put on the Chicago West Division Railway, and on its protégé, the Passenger Railway, have attracted unusual attention. The backs of the seats, which have bright brass fittings, are reversible; and "parties" are able to face all in one direction throughout the car, or on any portion of the rows, or, if preferable, two adjoining rows can sit vis a vis.



### Phantasms.

There is an old proverb to the effect that the farther one gets from home the more news may be heard concerning one's own neighborhood. And a strange tale, about Central Illinois, appears in a California paper, under the caption,

#### IS THIS TRUTH OR POETRY ?

And our Californian contemporary states that there is a funny sort of a railroad running in Central Illinois through a rich farming country, and is owned and managed by wealthy farmers. The conductors, engineers and brakemen are farmers' sons, who have grown weary of raising cattle and corn, and who have taken to "railroading" as a relief. A train starts from each end of the road every morning after breakfast, runs to the opposite end of the road by dinner time, returns again for tea and ties up for the night. As there is no telegraph lines connected with the road, nobody at any of the stations knows when a train is coming until it arrives in sight. As the rails are laid on ties placed on the flat prairie, and as no grade exists from one end of the road to the other, the tall grass has an awkward habit of getting under the wheels and stopping the train. Not infrequently, also, the light rails spread apart and the cars run off the track and go tumbling along on the virgin prairie. The passengers ride in a car reserved for them in the rear of a long line of freight cars. Half of this car is partitioned off, in order that it may serve for carrying mail bags, express matter and baggage. Not infrequently passengers walk into a village ahead of the train and announce that the cars will follow them in an hour or two, provided they can be kept on the track long enough. Sometimes a locomotive gets stalled on some one of the several gentle hills along the line. The trainmen thereupon quietly wait until the other engine appears. Then the two engines draw the train up the hill. Notwithstanding, this little railroad hauls large quantities of freight and is making money for its stockholders.

#### A New Orleans paper publishes a strange description of a SCENE IN A BOSTON NIGHT CAR.

It says that a neatly attired and modest appearing young woman boarded the night car on the Washington street line, in the vicinity of Chester Park, on a recent Sunday morning, on the 2.30 trip up. After she had taken her seat, she beckoned to the conductor to come and take her fare, which he prepared to do. She passed him a twenty-five cent piece, remarking as she did so that she wanted him to take out for two trips; that she was going to ride to the station and then back down town, where she resided; that she had been watching with her sick sister for two nights, and was very tired and sleepy, and would take one of the corner seats and try and get a little rest during her long ride; that she might possibly fall asleep from the effects of her protracted vigil, and was particular to request the conductor to see that she was properly protected if she lost consciousness. At this time she was the only passenger on the car. When it had arrived at the end of the route, the conductor noticed that the young woman had fallen into a deep sleep. The horses were changed, and the car started on its downward trip. When near the corner of Dover street three tough-looking fellows got aboard, and the moment their eyes fell upon the sleeping girl they cast some low reflections upon her character, which was in keeping with their appearance, and one went over and sat down beside her, and seemed disposed to act in an insulting manner. The conductor saw the misconduct and told the fellow he must stop that business or he would put him off the car; that the girl was eminently respectable and would be protected by him. This was met by some ribald jest as the conductor left them and took up his position at the rear door. He had hardly turned around when the same party he had spoken to was again disturbing the young woman. For the second time the conductor approached him, and in a voice somewhat louder than he had at first spoken told the hoodlum that, if he continued his impropriety, he would have him arrested by the first officer he met. This loud talk had awakened the young woman just in time for her to overhear the conductor's threat. Leisurely arising from her seat, she put one hand in the

pocket of her dress, and in a flash her eye was leveled along the glittering barrel of a revolver that she held at full cock, and pointed directly at the head of the blackguard who had been so impudent. There was perfect composure in her whole body, and her keen black eyes had no uncertain meaning. In a low, firm voice she said to the conductor: "I will save you the trouble of having these men arrested. Now that I am awake I can take care of myself, and if these contemptible scoundrels offer me one insulting word, or make any improper advancement toward me, however slight, I will shoot them the same as I would a cur," and everything was corroborative of this statement. The three nighthawks jumped to their feet in an instant and slunk away toward the door of the car, remarking as they did so, and at the same time keeping their eyes upon the shining barrel of the pistol, that it was an ugly looking thing to be so near to. They left the car hastily when they reached the platform. After their departure the young woman composedly resumed her seat, closed her eyes and in a few moments was asleep again. She wasn't disturbed a second time. She refused to give her name, as she said she wasn't looking for notoriety; but those present voted her a sample girl.

Boston, in its turn, circulates a piece of news on

#### DANGERS OF FRENCH INVENTORS.

M. Juibert, a mechanical engineer, of Paris, recently made an invention which is said to increase materially the speed of railway travel. The journals discussed the matter at length and predicted for M. Juibert a great future. However, the other day, as the inventor sat in his workshop, a stranger suddenly rushed toward him and began belaboring him with a cane, exclaiming excitedly, "This will teach you not to make such murderous inventions that will enable my mother-in-law to reach my house in six hours instead of twelve." M. Juibert caused the arrest of his assailant, who is said to be a well-known merchant by the name of Bolivet.

An elegant periodical, issued a long way from Pullman, Illinois, has the following on

#### PHANTOM TRAINS.

"Mrs. George M. Pullman, the wife of the palace car millionaire, usually travels in a train of four private cars—one a drawing-room for reception and reading purposes, with easy chairs, lounges, piano, etc.; another, a dining car, equally elegant; another, a sleeping car, perfect in its appointments, and another for the accommodation of six blooded trotters and carriage horses."

The above highly-colored article is taken from an exchange. These must be the "Phantom" trains which McHenry claims are run over the Erie system, which nobody ever saw.

AGRIPPA is suggested (by the San Francisco *Examiner*) as an appropriate name for an engineer (or grip-man, as they call him in Chicago, etc.) on a cable car.

PRESIDENT Thurston, Jersey City and Bergen Horse RR. Co., informs us that the New Jersey act to regulate the hours of labor on street railways is prejudicial to the employees. The hours for duty are limited to 12 consecutive hours out of every 24, whatever the terms of his employment may be; and out of that must be deducted half an hour, at least, for each meal.

THE incorporators of the Meigs Elevated Railway Company (under the Act of 1884, Chapter 87) are: Joe V. Meigs, Wm. S. Butler, Wm. A. Russell, Roland Worthington, Thos. W. Pierce, Geo. E. Harrington, J. W. Johnson, Chas. E. Powers, Henry Hastings, Nathan Appleton, Franklin E. Gregory, Edgar E. Deane, Geo. A. Alden, Frank Jones, Geo. J. Carney, and their associates.

THE success of the Fifth street (cable) line of the Metropolitan Street Railway Company, Kansas City, Mo. (E. J. Lawless, Superintendent), is remarkable, its earnings averaging nearly \$500 a day, having been in operation only a month. The horse cars formerly used on this line only averaged \$175 per diem. Such an increase (about 175 per cent.) will tend to "boom" cable railways, especially in comparatively small cities.

# The Street Railway Gazette.

Annual Subscription (Including Postage).	Per Copy
United States, Canada.....	\$2.00. .... 20c.
Great Britain, Ireland, India, Australia.....	10s. .... 11d.
Germany.....	9mk. 75 pf. .... 89pf.
France, Belgium, Switzerland.....	11fr. 35c. .... Fr 1.10.
Spain.....	11ps. 95c. .... Ps 1.10.
Austria, Holland.....	5fl. 74c. .... 53c.
Italy.....	12 lire. .... 1¼ lira.
Venezuela.....	12 bolivars. .... 1¼ bol.
Mexico.....	\$2.96. .... 30c.

*Ann. Subs. in Argentine Republic, 2¼ pesos; Brazil, 4 milhets; Turkey, 54 piasters*

Registered Cable Address=TRAM, CHICAGO.

**PUBLISHERS:**

**THE WRIGHT - MONROE COMPANY.**

Augustine W. Wright, - - - - - President.  
 E. V. Cavell, - - - - - Secretary.  
 S. L. K. Monroe, - - - - - Treasurer.

**GENERAL OFFICES:**

CHICAGO, - - - - - NEW YORK, - - - - - BOSTON.

**CHICAGO:**

9 LAKESIDE BUILDING.

P. G. Monroe, - - - - - General Manager.  
 William Hughes, - - - - - Editor.  
 Edward J. Lawless, - - - - - Associate Editor.

**NEW YORK:**

181 BROADWAY.

Henry C. Lockwood, - - - - - Resident Editor and Manager.

**BOSTON:**

19 TREMONT ROW.

T. P. Pemberton, - - - - - Resident Editor and Manager.

**EUROPEAN OFFICE:**

LONDON: W. S. G. Baker, Jr., (care Brown, Shiple & Co.), Res. Mgr.

**BRANCH OFFICES:**

ATLANTA, Ga.: Chamber of Commerce Bldg., Wm. Minnigerode, Mgr.  
 SAN FRANCISCO, Cal; 1222 Bush St.,—G. W. Fairchild, Manager.

**CANADIAN AGENCY:**

TORONTO: 53 Magill Street,—Thomas Henry, Manager.

RICHMOND, Mo., is to have a street car line.

ENGLAND is looking to America for electric motors for street tramways, and several companies are undecided whether to make love to the cable manufacturing companies or the electric railway constructors of the United States.

JOHNSON steel rails are being laid everywhere. Our pointers in this number show that these admirable rails are taking the place of other rails in many old tracks, as well as on new roads.

MR. SHIPPE, who purchased the Abilene street railway, informs us that four and a half miles of track will be laid between now and the first of August. He wants bids for laying a mile and a half at once. See "pointer" under Kansas.

MAVOR Hewitt endeavors to have all railway companies, that may adopt the cable system in New York, burdened with a tax of one cent per passenger. The mayor of Topeka, Kansas, with the city council, on the other hand, have given every encouragement to the promoters of street railways, for which "there is much rejoicing." Truly "civilization travels westward."

PROGRESSIVE street railways send their managers to investigate now, when it is resolved to get one of the newest motors. They will not buy until they carefully examine the various makes seeking public favor. Thus, in common with others, the Wichita and Suburban and Wichita and Valley Centre Motor line (consolidated) appointed Mr. D. P. Alexander to go east and purchase three motors and six coaches for the company.

ELEVATED Railways have been chartered for Philadelphia. A telegram from Harrisburg, Pa., June 3rd, says: A charter was granted at the State Department to-day to the Consolidated Transit Company of Philadelphia; capital, \$5,000,000. This is the new elevated railroad company, the line of which will be twenty-six miles through the streets of Philadelphia and will be built by the Wanamaker-Dolan syndicate.

SUMMER cars are now running on all prosperous street railways. And more are to follow, right away; whereby car builders have been busy in the recent past, and continue so. The John Stephenson Co. (Ld.), New York, are extremely active; Pullman's Palace Car Co., Chicago, are manufacturing a large number of street cars, especially for the electric railways running and in course of construction; and the Brownell and Wight Car Co., St Louis, are very full of orders, and their summer cars this season are elegant.

THE general success of street railways is not without an occasional exception; and one can not fail to sympathize with the poor horses at Hutchinson, Kan., when reading that "the street car track will have to be paved eventually, as the cars, light as they are, are too heavy for the horses when the latter have to wade through mud. No street car line ever began with a better lot of horses but, already, some of them begin to show signs of wearing out. So far, the line is not profitable to its owners, but indications are that its business will increase every day."

MOTIVE power is left in the balance for future decision by many of the street railway corporations now forming in every direction. An example thereof is furnished by a correspondent describing "South Omaha coming to the front in a progressive way," saying: "The near southern neighbor of Omaha—in fact its most precocious business child,—is keeping step to the music of progress right along. The latest movement is that for a street railroad to be operated by horses, cable, motor or electricity. The company has been formed, and the articles of incorporation filed. The capital stock is \$250,000 with a privilege of increasing to \$500,000."

HUTCHISON, Kansas,—as if it were to make up for the bad condition of its street railway horses,—will now try her hand at leading the cities of Kansas, of any and all sizes; and, as a starter, says a local newspaper, will put down five miles of electric street railway. "This is the newest and most successful motive power now known for the purpose of propelling street cars. \* \* \* There are no horses, no steam, no nothing that is in view but the car itself. In fine, it is the biggest thing out. The scheme originated with Mr. S. A. Beebe, the manager, and a large stock company of the Hutchison Water, Light and Telephone Company. Upon consultation with the Edison folks, a careful inspection of the city by an expert sent here from New York was made, and he pronounced the scheme feasible."

THE terrible fire, reported in another column, wherein some 1,200 street railway horses were burnt in New York, has given occasion for newspaper and periodical comments—all condemning horses as means of propelling street cars. The writers, however, differ regarding what should be substituted as vigorously as they are unanimous in reference to horses. One set insist that the endless rope or cable is "the coming power," while others, with Mr. Pope, believe that electricity is to supersede the cable. Electric railways, certainly, are no longer experiments; they have come to stay, and prosper—in America, at all events. The information concerning them, in another part of this issue, is conclusive on that point. And in England the *English Mechanic* speaks of what electric railways they have over there as "successful experiments," and declares that "electric locomotion" would have made more headway, ere this, if it was not for "the red tape which hampers every enterprise."



CITY officials from Philadelphia recently visited Boston for the special purpose of examining the construction of the Meigs Elevated Railway, at Cambridge. They were entertained by Mayor O'Brien, the city aldermen and council of Boston, as well as by Captain Joe Meigs. Philadelphia will have an elevated railroad on the Meigs system. Boston itself is still pushing street railways but will neither go above nor below the surface.

THE Rapid Transit Co., of Topeka, Kans., have taken great pains to ascertain which is the best motor; John Francis, president and general manager, and John Norton treasurer of the company, have gone to Birmingham, Ala., to inspect a steam motor which is being operated on a rapid transit line in that city; and they will inspect different styles of motors operated in different parts of the country, before making their choice, as they intend "that their line shall be second to none in the country in equipment."

"A HUGE deal in dirt," has occurred near Omaha, and which means more for Omaha than anything that has transpired for some time. It was nothing less than the sale of the well-known Patrick farm, west of the city, to a trio of well-known Kansas City men. They bought 615 acres, for which they pay the magnificent sum of \$615,000. Messrs. F. L. Underwood, N. D. Allen, and W. H. Craig, of Kansas City, are "the shrewd financiers" who have made the purchase, having become "convinced, after thorough investigation, that Omaha could not be other than a great city." And the company, as soon as matters can be got in shape, will build either a motor or a cable line direct to the new addition from the heart of the city.

"THE capital of Kansas (Topeka), sends greeting to the capital of Massachusetts, and commends the judgment and business foresight of her citizens, who are aiding in building up the queen city of the west." That expression of gratitude from the city of Topeka to the capitalists of Boston affords a pleasing contrast to the "dog in the manger" principle of less prosperous cities, who scoff at outside aid. The syndicate (whose deal is referred to more fully in our pointers, under Topeka) consists of some of the wealthiest men of Boston, represented by Mr. Frank R. Cordley, a well known Boston banker. They now own and control the most valuable street railway property in the State of Kansas, to which they have been heartily welcomed by the people interested. And the street railway community, in general, may well return the compliment and "commend the judgment and business foresight," and the good example of the citizens of Topeka. "Let brotherly love continue."

STORY'S miserable story is now ended, we hope. Judge Gresham has denied the motion for an injunction against the North Chicago Street Railroad Company, which had been made ostensibly by Nathan Lorie, the power behind the throne being Allan C. Story. The complainant owns the lot and buildings on the northwest corner of Clark and Illinois streets, and avers that the cable railroad when it turns the corner will materially damage his property. "Even if the right to construct the road is not clear," the Court says, "the complainant is not entitled to the relief prayed for unless he has been or will be disturbed in the enjoyment of his property, for which he has no adequate remedy at law." The Court held again that complainant had no right to the centre of the street, but that the city owned the streets in fee, his sole right to the streets and tunnels of the city being the common right of easement, and this he did not lose by the cable road. "If he can show that the construction and maintenance of the tracks in front of his property result in special damage, and not one in common with the public, then his remedy is at common law."

A BOSTON street car conductor says that of all the passengers he carries Chinamen give him the least trouble. "They get the car quick," says he, "keep their mouths shut, never raise a row, know what the fare is, and have the change to a cent when I ask for it."

## The Railway Jubilee, Paris, 1887.

To the Editor of the STREET RAILWAY GAZETTE:

SIR.—I am requested by the Executive Committee, in Paris, to ask the favor of appealing through your columns for the loan of any objects, books, medals, drawings, etc., relating to the history of railways and means of transportation generally, both ancient and modern, in this country.

I am directed, also, to say that all expenses of forwarding and returning the same to the lenders, packing and unpacking, will be defrayed by the Executive, and insured for the value the lender may put upon each object, and that special attendants will be told off for their safe custody.

All communications on the subject may be addressed to M. G. Senechal, 8 Faubourg Montmartre, Paris, or to Mr. Geo. L. Fowler, M. E. (of New York City), Commissioner in charge for the U. S., Palais de l'Exposition, Bois de Vincennes, Paris, France. By addressing communications direct to Paris much valuable time will be saved.

Hoping you will kindly insert the above, and accept the thanks of the Executive Committee.

I am, yours truly,

JOHN W. WESTON,  
Com. Gen. for the United States.

## Street Railways of Maine.

These comprise the lines of the Portland Railroad Company,  $7\frac{3}{4}$  miles, and the Ocean Street Horse Railroad Co.'s track, operated by the former,  $1\frac{1}{2}$ ; total,  $9\frac{1}{4}$  miles. Also the Lewiston and Auburn Horse Railroad Co.'s road, which extends along the principal streets of Lewiston and Auburn, to Lake Auburn, about  $7\frac{3}{4}$  miles. The Orchard Beach Railroad, a three-mile road from the Old Orchard Depot (B. & M. RR.) to the mouth of the Saco River, is really an extension of the Boston and Maine RR.; it is operated during the summer months only, and furnishes a convenient line of travel to the people who occupy cottages upon the shore, as well as an attractive and pleasant ride for summer visitors at Old Orchard.

The Railroad Commissioners' Report for 1886, says that the Lewiston and Auburn Horse RR. made much improvement during the year. "The horses are well stabled and fed, and we should judge treated with kindness and care, as all of them appeared in good condition. The cars and other equipments are in good condition. The business of the road has largely increased and presents a satisfactory result for the past season." Mr. Frank W. Dana, is president and general manager, and Mr. J. E. Fairbanks, superintendent. The offices are at Lewiston. The capital stock of this company is \$90,300, held by 44 stockholders; the total liabilities, Sept. 30, 1886, amounted to \$122,700; and their profit and loss balance showed a deficit of \$54,745.81. The road's construction cost \$32,714.32, and the equipment \$24,075.36; other investments absorbed \$7,370.40. The total income for the year was \$14,438.48; total expenditure, \$12,140.79; leaving a net income for the year of \$2,297.69. Total number of passengers carried was 236,854.

The Portland Horse RR. Co., has a capital of \$157,600, held by 87 stockholders (in Maine); total liabilities \$188,400; profit and loss account shows a surplus of \$2,491.01. Total income for last year was \$84,131.17; expenditure was \$77,594.21; leaving a net income of \$6,536.96, of which \$6,304 was paid in dividends. Total number of passengers carried was 1,558,623.

Other street railways in Maine in course of construction or projected are: The electric railway at Bangor, De Camp's street railway at Calais, and the lines of the Biddeford and Saco Horse RR. Co. (which may be operated by animal, electric or cable power), and of the Rico Electric Manufacturing Co., at Portland.

IN an action, tried before Judge Truax and a jury, in which the plaintiff was George J. Leslie against the Manhattan Railway Company, New York, for damages to the rental value of 15 Division street, between 1879 and 1884, by the construction and operation of the elevated road, a verdict was rendered for \$3,550.

### Personals.

MR. PULLMAN (Chas. L.) was recently seen in St. Louis and Kansas City.

SECRETARY C. J. GOODRICH, Minneapolis Street Railway Company, was also in Kansas City.

MR. BARR, of the St. Paul (Minn.) cable road, was in Kansas City and St. Louis.

MR. R. E. GRAVES, of Dubuque, President of the Rasmussen Cable Company, paid a flying visit to Chicago.

MR. MCKNAPP, Assistant Superintendent Grand Rapids Street Railway, is in Chicago.

MR. CAMPBELL, of Grand Rapids, is also there.

MR. MCNEILL, of the Rasmussen Cable Company, is in New York.

MR. ANES, President of the Lincoln (Neb.) cable line was in Chicago lately.

MR. LAUGHLIN, of Jones & Laughlin, was in Chicago lately from Pittsburgh.

MR. F. T. LERNED has been seen lately in Richmond, Va., Providence, R. I. and Boston, Mass.

MR. JOHN A. BRILL will shortly sail for Europe on business for his firm.

MR. ED. BEADLE, general manager of the Railway Regulator Manufacturing Company, recently made a trip to Buffalo.

Mr. Lamb, secretary and treasurer of the Memphis, Gr. and Pr. R. Co., is one of the most influential and successful real estate men of Memphis.

MR. CHAS. K. DICKSON, secretary of the Northern Central R. R., at St. Louis, is running "a land office business" with his patent rail brace, and a capital thing it is, too.

MR. D. F. LONGSTREET, of Providence, R. I., passed through Chicago on the 9th of May, en route to St. Louis, Kansas City and Denver.

MR. FRANK WHELAN, of the firm of Vogel & Whelan, New York, exhibited the model of a new cable system, in Providence, R. I.

MR. HENRY ROOT, the well-known cable railway builder, of San Francisco, is in Kansas City, Mo., and delights the people there with his talk about the cable system in California.

MR. C. M. BARCLAY is manager of the newly opened Western Office of the Sprague Electric Railway and Motor Co., at 182 Dearborn street, (Adams Express Building), Chicago.

MR. W. K. CARLISLE has resigned his position as treasurer of the Wichita City Ry. Co., and Mr. G. N. DIXON has been elected to the office. Mr. W. B. RYDER has also been appointed assistant manager of the company.

MR. FRANK L. POPE, the well-known expert in electrical matters, says that he has not the slightest hesitation in predicting the adoption of electricity for street cars everywhere within a very few years.

GENERAL GEORGE W. WINGATE is one of the prominent lawyers of New York connected with street railway litigation. He has promised Justice Barrett that the Metropolitan Transit Company will not attempt to build its road in Broadway until the court of last resort has passed upon all the questions in litigation.

MR. J. L. WINDSOR, having been a couple of years in the admirably conducted offices of the Chicago City Railway Co., assisting President Holmes, has undertaken the superintendency of the Auburn City Railway Co., N. Y.; and he has left Chicago with the best wishes of his whilom confrères. The condition of the "overland route" he has gone to take charge of is stated among our Pointers.

MESSRS. A. H. DAVIS, St. John Boyle and H. H. LITTELL (Pres., V. Pres., and Supt.) of the Louisville City Ry. Co., Ky., were elected, May 21, on the board of directors of the Louisville, Evansville and St. Louis Ry.; Mr. Littell being appointed vice-president thereof. They represent the Corydon Stone company which has lately purchased the L. N. A. & Corydon railroad, and has placed the same in good running order, making all connections with L. E. & St. Louis RR. company's trains.

### POINTERS.

#### ALABAMA.

*Birmingham.* The Birmingham Union Railway Co. are extending their tracks below Elyton a mile and a half. All their lines in the city limits are double tracked, and they are replacing T rails in the paved portion of the city with girder side-bearing rails.

The Highland Ave. & Belt RR. Co. are constructing 20 miles of track, with 30, 35 and 56 lbs. T rails, 4 ft. 9 inches gauge. They will have 5 dummies and 2 locomotives, with 44 cars. H. M. CALDWELL is president, and W. J. MILNER, secretary and general manager.

*Calera.* The South Calera Land & Improvement Co. will build a street railroad two miles in length.

*Mobile.* All the street railways of this city were transferred, May 18, to Messrs. W. B. DUNCAN, R. K. WARREN and Charles L. FULLER. They represent New York and Nashville capitalists, and have invested their money on the chance of Mobile's improvement, which they claim to be most favorable. The public receives the news with pleasure, and great improvements are expected. The sale includes all stock, buildings, cars and franchises.

*Montgomery.* The Van Depoele Company's 250 h. p. generator has been running for the past week in the Capital City Electric Railway's station at Montgomery, Ala. The company now has six cars running, and Mr. Dunham, the superintendent, expects to operate eighteen cars within a couple of weeks.—*Electrical World* (May 21).

From a local correspondent we also learn that "the Van Depoele electric system was successfully introduced on nearly all the lines of the Capitol street railways May 10. Electric cars are running now beyond the city to Highland Park, the cemetery and Hammer Hall without a hitch. Mr. Van Depoele seems highly pleased with the marked success of his system."

*Selma.* The Selma Street Ry. Co. still contemplate extending their road.

#### ARKANSAS.

*Argenta.* The Argenta & Big Rock Street Railroad Co. has been incorporated by Samuel B. Adams, J. K. Brantly and others; capital, \$50,000.

*Fort Smith.* The Fort Smith Street Railway Co. ordered, Feb. 25 last, eight additional cars and four miles of the Johnson steel girder rail (45 lbs. and 38 lbs. to the yard), and will have the extension completed by the 1st of September next.

*Texarkana.* The Texarkana Street Railway Co. are using 24 lbs. T rails, and are now laying one more mile which will be finished by July 1st. They have a charter for Texarkana, Arkansas, and Texarkana, Texas, for thirty years.

The State Line Ry. Co. has been incorporated by E. A. Warner and others, with a capital stock of \$25,000.

#### CALIFORNIA.

*San Francisco.* The City RR. Co. will probably change its system to cable within the year.

The Central RR. Co. are considering the question of building a cable road on Turk and Sixth streets, in addition to their present horse railroad system.

The Main Street and Agricultural Park RR. Co. have six new cars in course of construction.

The Omnibus RR. and Cable Co. are changing their line into a cable road.



Ground has been broken on the Castro Street Cable line. Along Market street the road will be constructed without interfering with the running of the dummy trains.

*San Jose.* The San Jose and Santa Clara RR. Co. will change their road to a double track, 3-foot gauge, and will use electricity.

*San Luis Obispo.* A street railroad franchise for forty years has been granted to Edwin Goodall and others.

*Santa Ana.* The Santa Ana, Orange and Tustin Street Railway Co. expect to build four additional miles this season and put on steam motors on all the line (8½ miles). Sixteen lbs. steel T rails are used. Gauge is 3 ft. 6 inches.

*Santa Rosa.* A street railroad company has been organized by A. B. Ware and others. Capital, \$25,000.

#### COLORADO.

*Canon City.* A franchise for a street railroad has been applied for by J. P. Chapman.

#### CONNECTICUT.

*Birmingham.* An Electric Street Railway is badly wanted here, and projectors should correspond with Mr. Thomas Wallace, Ansonia, Conn.

*Bridgeport.* The Bridgeport Horse RR. Co. are replacing the old style "saddle rail" with centre-bearing on a mile and a half of their road. They have also placed two large castings on both of their railroad crossings.

*Waterbury.* The Street Railway which opened here Nov. 3, 1886, is being well supported. The John Stevenson Co. furnished the cars. Mr. E. A. Bradley, the superintendent, is very proud of the company's horses, of which there are nearly 100; and, outside of the Jersey City & Bergen Railway, but few can boast of better looking or more valuable stock.

*West Haven.* The New Haven and West Haven Horse RR. Co. are contemplating additional horses and cars.

*Westport.* The Westport and Saugatuck Horse RR. Co. will soon put on a new double car.

#### DAKOTA.

*Watertown.* The city has granted to Chas. Josslyn an exclusive twenty years' franchise for street railroads. The street railroad and the motor line to Lake Kampeska are to be completed within one year and six months respectively.

*Yankton.* A street railway company has been organized here, and the directors instructed to procure bids for the construction of two miles of track, the work to commence within sixty days.

#### DELAWARE.

*Wilmington.* The Front and Union Street Railway Co. contemplate lengthening and building three 8-ft. cars.

The Wilmington City Railway Co. will build a new branch 1½ miles long, to reach a cemetery half a mile beyond the city limits, this summer; to be operated by electricity—probably using the Sprague system (overhead wire).

#### DISTRICT OF COLUMBIA.

*Washington.* The Metropolitan RR. Co. are having 25 new two-horse cars built, which will commence running in October next.

#### FLORIDA.

*Pensacola.* The Pensacola Street Car Co. contemplate an extension of two miles. And they are going to change their present 5-ft. gauge to the standard 4-ft. 8½ in.

#### GEORGIA.

*Atlanta.* The Atlanta Street RR. Co. are extending their tracks a mile and a half—to Piedmont Exposition Park—and will put on 11-ton dummies, to be used in connection with horse cars.

The West End and Atlanta Street RR. Co. are about putting on seven additional cars and one dummy.

The Metropolitan Street RR. Co. "expect to put in an electric plant, as soon as they find something to suit them."

*Savannah.* The City and Suburban Railway have just completed their new stables and car sheds, and intend building a new depot.

The Coast Line RR. are having two new cars built for their suburban line.

#### ILLINOIS.

*Aurora.* The Aurora City Ry. Co., who have now 5½ miles single track, are about to lay an additional mile, and put on two more cars, together with 15 mules.

The Western office of the Sprague Electric Railway and Motor Company are installing at the Aurora shops of the Chicago, Burlington & Quincy Railroad, a 7½ hp. motor to operate the traveling car table, which conveys the cars while in progress of building from one shop to another.—*The Electrical World.*

*Belleville.* The Citizens' Street Railway Co. have received and placed two new summer cars from the Laclede Car Co., St. Louis, Mo., and they contemplate the adoption of one of the electric street railway systems. They also intend making some extensions.

*Bloomington.* The Bloomington & Normal Street Railway, composed of 5¾ miles of track connecting the two cities, and including several branches, was sold, May 19, by Asa H. Moore to W. F. Saddle, of Carlisle, Pa., and John Graban and J. H. Hursh, of Newville, Pa. This includes the stock and barns. There are ten cars and fifty-seven mules. The road originally cost \$85,000. The selling price is understood to be not far from \$125,000. The line will be extended several miles.

*Cairo.* The Cairo St. Ry. Co. intend to make an extension of 1,000 ft. on Commercial av. to the Union Depot. The C. V. & C. RR. had their track on this avenue, which has now been removed, and the street railway will take its place.

*Chicago.* The Chicago City Railway Co. are building 30 grip cars and 100 box cars. Their cable extension on State St., from 39th to 63d street (3 miles of road), was formally opened May 21, under the superintendence of Secretary H. H. Windsor, with Foreman O'Brien in charge of the grip. Everything passed off smoothly and without a hitch—except a stoppage near the new engine house, whence the new cable is driven, to enable the representatives of the STREET RAILWAY GAZETTE, and those of the Chicago daily papers, to inspect the machinery.

The work of constructing the Cottage Grove avenue and Fifty-fifth street cable line progresses rapidly, and it will be but a short time ere the old dummy will be taken off and cable cars substituted for passenger traffic between Hyde Park and the city limits. The tracks for the conduit have been dug as far east as Washington avenue on Fifty-fifth street, and the work of setting the braces goes along at a rapid rate. The Chicago City Railway Company have an immense gang of men at work, and the rapidity with which they do the work shows experience. The cable line, when completed, will run on Cottage Grove avenue to Sixty-seventh street, the northwest entrance to Oakwoods Cemetery, on Fifty-fifth street from Cottage Grove avenue to Lake avenue, on Lake avenue to South Park Station, thence through the block west to Jefferson avenue, and north to Fifty-fifth street, thence connecting with the Fifty-fifth street line, and forming a loop, doing away with any switching. The cable will be as near to the Fifty-seventh street entrance to Jackson Park as the Illinois Central, lacking about 150 feet, and will be just across the railroad tracks from the Fifty-sixth street entrance.

The North Chicago Street Railroad Co. are progressing rapidly with their cable system. And they will lay, by the 1st of August, twelve miles additional horse-car track.

The total length of street railway tracks (single) in Chicago at present is: Chicago City, 104¼ miles; West Division, 100 miles; North Chicago, about 50 miles; Chicago Passenger, about 22 miles; total, 276¼ miles.

A certificate of incorporation has been issued at Springfield, Ill., to the St. Louis Cable Railway Association at Chicago; capital stock, \$100,000; incorporators, Julius S. Walsh, Edward Walsh and O. W. Meysenburg.

*Galesburg.* The College City St. Ry. Co., who have five miles of track in operation, are going to make an extension of ¾ mile, and add two new summer cars, together with additional stock and a number of new sidings.

*Joliet.* The Joliet St. R.R. Co. contemplate erecting a barn and car sheds.

*Lake View.* The petition of the North Chicago Street Railroad Co., asking permission to use a centre-bearing rail on their new line on Belmont av., etc., was refused by the Board of Trustees May 16.

*Mattoon.* The Mattoon Street Railway Co. was licensed by the Secretary of the State, May 11th, capital stock \$75,000, to build and operate a street railway in the city of Mattoon. Incorporators, Isaac B. Craig, Frank Kern and William B. Leitch.

*Moline.* A certificate was filed at Springfield, May 25, to record the increase of the capital stock of the Union Street Railway Co., at Moline, to \$50,000.

*Peoria.* The Central City Horse Railway Co. are adding half a mile to their present ten miles of track.

The Peoria Horse R.R. Co. will also build half a mile to their present six miles of road.

The East Bluff Peoria Horse R.R. Co. have just completed a mile and a half of track.

*South Ottawa.* License of incorporation was granted to the South Ottawa & Ottawa Street Railway Co., at South Ottawa, May 6; capital stock, \$30,000; incorporators, Lester A. Rose, F. E. Mayo, James Mulligan, Jr. and Louis W. Hess.

*Springfield.* The Springfield City Railway Co. are paving half a mile of their track, and relaying three-quarters of a mile.

*Sterling.* The Citizens' Street Ry. Co., of Sterling and Rock Falls, was incorporated, May 25; capital stock, \$25,000; to operate a street railway in the city of Sterling and Rock Falls. Incorporators, John G. Manahan, Clarence L. Sheldon, Virgil B. Ferguson, John W. Alexander, George W. Chamberlin, Daniel B. Strickler and Moses B. Rutt. The work of construction will proceed at once.

#### INDIANA.

*Elkhart.* The Citizens' Railway Co. expect to add 20 horses or mules to their motive power at once.

*Greencastle.* The Greencastle City Street R.R. Co. contemplate several modern improvements, and a three-quarter mile extension, and additional cars.

*Indianapolis.* The Citizens' Street Railway Co. will probably build two miles of road, using the Johnson street rail (38 lbs.).

The street car drivers (there are no conductors in this city, none but bobtail cars being used) struck, May 20, for an increase of wages from 14 to 20 cents. On Sunday (May 15) several of the drivers were arrested (at the instance of the city authorities) and fined for failing to call out the names of streets, as required by the ordinance. This had been a dead letter for years, and its revival gave the men an opportunity to demand higher wages. The men were divided in opinion as to the expediency of the strike—most of them having returned to work—until the local assembly of the Knights of Labor took the matter in hand, May 29, and ordered all Knights to leave the company's employ. Thereupon 41 Knights of Labor, employees of the street railway company, drew up a petition to Powderley, protesting against the mandate of the district assembly and asking for a hearing. The petition sets forth that a majority of the Knights in the employ of the company are signers of the petition, and that the strike is against their wishes, besides being wholly unsupported under the rules of the order.

*Muncie* is to have an electric railway.

*New Albany.* The New Albany Railway Co. contemplate making some improvements this year.

*Portland.* A street car company has been organized with a capital of \$50,000.

*Terre Haute.* The Terre Haute Street Railway Co. are going to put on five additional cars, and will build four miles more track.

*Vincennes.* The Vincennes Citizens' Street Railway Co. contemplate building one mile more track this year or next spring.

*Washington.* The Washington Street Railway Co., capital stock \$25,000, has been incorporated by Joseph J. Lacy and others.

#### IOWA.

*Boone.* The Boone & Boonsboro Street Railway Co. will probably extend their line as soon as "certain improvements are built."

*Colfax.* The Colfax Street Railway Co. has been incorporated by Willard T. Block, Sidney Williams, Henry Fellows, Frank T. Kegley and Isaac C. Balthis. Capital, \$15,000. The purpose is to construct, equip and operate street railroads in the incorporated town of Colfax, and to any place of public resort in or near the suburbs thereof.

*Davenport.* The Davenport Central Street Railway Co. are now relaying their track preparatory for using cable or electric power.

*Des Moines.* The Capital City Street Railway Co. intend building seven miles more track this season, and to buy twelve more cars, with additional horses, and build stables, etc.

*Dubuque.* The Dubuque Street Railway Co. contemplate an extension of one mile, and will build a new barn and car house.

*Keokuk.* Here's a chance of doing good! The Keokuk Street Railway Co. says: "We ought to build two miles additional track, but the company is too poor. We will build two open cars this summer."

*Lyons.* The Clinton & Lyons Street Railway Co., who have now four and a half miles of single track, contemplate a mile and a half extension in Lyons.

*Sioux City.* The Sioux City Street Railway Co. will make an extension of from three to five miles during the present year.

*Waterloo.* The Waterloo Street Railway Co. contemplate enlarging their barn.

#### KANSAS.

*Abilene* is to have a street railway, the material for one having been already purchased by the president of the Abilene Real Estate Co. (M. M. Shipe). Elegant new cars have arrived; the track is to be laid forthwith; and the Abilene Street Railway will soon be in operation. The organization of the company was pointed in the December GAZETTE.

*Atchison.* The Atchison Street Railway Company have filed an amended charter, increasing the capital stock from \$50,000 to \$150,000. And the council has granted them the right of way to double track Commercial street, from Second to Fifteenth streets.

*Blue Rapids.* A street railway, to connect the depots, is talked of.

*Clay Center.* Material for the street railway has arrived, and the work is progressing rapidly.

*Emporia.* Travel has so increased that the street car company has been obliged to double their number of cars to and from all trains.

The Emporia City Railway Company expect to make extensions forthwith.

*Fort Scott.* A belt line, three miles long, is to be constructed.

The Red Line track of the Bourbon County Street Railway will be extended south three-quarters of a mile, and west half a mile, to a track of land embracing twenty acres timbered and skirted by the finest stream of water in all this section, that is to be laid out as a public park. The company will put on seven new cars and twenty-four mules, and one motor.

*Girard.* The preliminaries for the building of the street railway are about perfected, hence work will very soon commence on it, and pushed on so that it may be fully equipped by July 1.

*Hutchinson.* The track of the Hutchinson Street Railway Company was completed to Riverside Park May 9, and cars are now running regularly.

The whole of the street railways in this city are to be converted to electric railways; the project is enthusiastically approved.



*Lawrence.* The Lawrence Transportation Company have bought an additional lot, 50 x 58½ feet, for yard and barn purposes.

*McPherson.* A correspondent, under date of May 13, says: "Ground for the street railway has been broken as far south on Main street as the Union hotel. Track-laying is going ahead under the pressure of a full force of men, who are making fast headway. But little if any grading appears to be necessary, the ground along the route being level and easily worked. It will not be long before the tinkle of bells will announce the completion and operation of the road."

*Newton.* The first street railway in this city is expected to be in operation by September 1st. Six miles are under contract, and building rapidly. The company have purchased the lot now occupied by the Episcopal church on Broadway, and will erect car stables as soon as the building is removed to the northeast corner of Peter Hart's property.

Another street railway franchise has been granted by the city council, the particulars of which have not yet come to hand, except that it is on the west side of the river.

James Dexter asks for a franchise for the South Side Street Railway Company, which will run from a point on South Main street to the Newton college. This makes three lines of street railways in this city, and public opinion is in favor of the franchise being granted without delay.

W. B. Rogers is trying to negotiate with the city authorities for constructing a street-car railway on State street from the Prairie Dog to the cemetery. The distance is two and one-half miles.

*Ottawa.* The first car made its trial trip on the Ottawa Street Railway May 25, amid great rejoicing by the citizens.

*Parsons.* The Parsons Street Car Company was regularly organized May 7, with Angell Matthewson, J. J. Frey, C. A. Rasbach, George Son and G. W. Hawk as the incorporating directors. Angell Matthewson was elected president, J. J. Frey, vice president, and G. W. Hawk, secretary and treasurer. Steps are being taken to begin the work of construction of the lines at an early day, and push them to completion as rapidly as possible. The shares are of the par value of \$10 each, and subscriptions for the same are received payable one-third cash, one-third in sixty days, and the balance in four months from date of subscription. The total amount of the capital stock is \$50,000.

*Peabody.* The Peabody Railway Company, has been organized by W. E. Scott and others of Topeka.

*Salina.* The street railway company here are considering the advisability of putting dummy engines on their lines. The law allows them to make seven miles an hour, "and the engine would be an excellent improvement on the average street car mile."

It has been decided to extend the line 1¾ miles, and work is proceeded with. The liberal donation of lots by Mr. L. O. Wight has caused the construction of this line to be made. The company agree to operate the line for at least two years. It opens up one of the best residence additions to the city.

*South Topeka.* The South Topeka extension of the Topeka City Railway is finished to a connection with the main Kansas avenue line at Tenth street, and cars are now running to Garfield Park.

*Topeka.* The West Side Circle street railway, of which ex-Governor Osborne is president, have purchased two miles of steel rails, and work will proceed without delay. The company owns about 600 acres along the route of the road, and has already secured guarantee subsidies from all property owners who have land through which the road passes.

From later intelligence we learn that the last mentioned line has been sold with the next named road.

The Topeka City Railway, with all its equipment and franchise, was sold, May 18, to a syndicate of Boston capitalists, represented in Topeka by Mr. Geo. F. Parmalee and Col. J. H. Broadus. The road was opened in June, 1881, and hardly paid expenses the first couple of years, but is now valuable. The property transferred by this new deal consists of ten and one-half miles of track, 116 horses

and mules, 29 cars, the barns and stables on Tenth avenue, material already purchased for about three miles of road, and the franchise owned by the Topeka City Railway Company, which gives the company the right of way on every street in the city of Topeka. The exact price paid for this valuable property is not known to the public, but we are informed by a gentleman closely connected with the purchasers that it approximates a quarter of a million dollars. The same syndicate have purchased 1,778 acres of land west of the city, for which they paid \$518,000. They also purchased at a large price the franchise of the Topeka Circle R.R. Company.

A mile and one-half of the tram rail is to be taken up, to be relaid with the Johnson girder, and the entire length of Kansas avenue is to be double tracked, which will require about one mile of new track. Extensions and branches to the extent of about one mile are also to be constructed, and a new stable and car sheds will be erected forthwith.

*Wichita.* The Wichita City Railway Co. will add 15 cars and 100 mules and build ten miles more track this season. They will double track three miles.

The Wichita Construction and Supply Co., builders and equippers of all kinds of street, cable and dummy railways (J. W. Hartzell, general manager), have just completed a steam motor line for the Wichita Rapid Transit Co. The road, which is five miles long, will be ready for operation July 1st. There are two motors, made by H. R. Porter & Co., and five cars are being made by the Laclede Car Co., St. Louis. 25 lbs. T rail is used; gauge is 3 ft. 6 in.

The Princess Motor Line Co. are working in earnest. A mile of track has already been laid, and rails for the remainder have arrived.

*Winfield.* Hon. John A. Eaton has purchased iron for five miles of new railway in Winfield, together with the necessary cars.

#### KENTUCKY.

*Hopkinsville.* Two companies from New York and Nashville have applications before the council to construct a street railway. The New York company have sent an engineer to make the survey, and he reports favorably. Horse power is to be used.

*Louisville.* The Louisville City Ry. Co. will build about five miles of new track this year, and reconstruct about three miles—substituting iron rail with steel.

#### MAINE.

*Lewiston.* The Lewiston and Auburn Horse R.R. Co. have just completed their car house, and have begun on a new stable; the car house and stable being separate buildings, about 40 x 120 feet each.

#### MARYLAND.

*Baltimore.* The Baltimore and Yorktown Pike Road Co. have laid 1¼ miles of double track and added 2 cars this spring—making the length of their tracks 8 miles (4½ miles single, and 3½ miles double track).

The Highlandtown and Point Breeze Ry. Co. are repairing the Point Breeze division, at a cost of \$3,000; also repairing the city track—using some new material.

Baltimore and Ellicott City are to be connected by an electric railway. The B. & O. Co., is said to be backing it.

#### MASSACHUSETTS.

*Boston.* The Boston Consolidated Street Railway Company has recently made improvements and additions on their buildings and plant. Among these are the new stables at Medford, which are now completed, and take the place of the stables that were destroyed by fire April 7 last. The company has purchased land at Somerville, and will build a stable for 200 horses; also a car house. And they have new locations in the streets of Somerville.

A new line from the Highlands *via* Columbus avenue to Charlestown, belonging to the Consolidated, will soon be running. Thirty new open cars (Jones's pattern) have arrived at the company's car house, and will be put on immediately.

A track to West Medford is contemplated by the same company. Its length will be about  $2\frac{1}{2}$  miles.

The Lynn and Boston horse railroad is laying a second track on Boston street, between Pine Grove cemetery and Washington street.

The West End street railway is a corporation organized under the general laws of Massachusetts, for the purpose primarily of furnishing transportation to residents on the land of the West End Land Company and vicinity; its stock is held by the trustees of the West End Land Company, except enough to qualify directors.

The Suburban Street Railway Company is virtually an adjunct to the West End Street Railway Company, and its stock is held by the trustees of the West End Land Company, except enough to qualify directors.

The Boston and Chelsea RR. Co.'s line is leased by the Boston Consolidated and operated by the Lynn and Boston RR. Co.

The Somerville Horse RR. Co.'s line is operated by the Cambridge and Consolidated Companies.

The line of the Winnisimmet RR. Co. is leased to the Lynn and Boston RR. Co.

The East Middlesex Street Railway Co. (formerly Stoneham) are now extending to a total of about 15 miles, passing through Woburn, Stoneham, Melrose, Malden, Revere, and Saugus, and are building stable ( $35 \times 158\frac{1}{2}$ ) and car house ( $44 \times 162$  feet) at Woburn; stable ( $70 \times 158\frac{1}{2}$ ) and car house ( $66 \times 165$  ft.) at Melrose; stable ( $105 \times 140$ ) and car house ( $66 \times 165$  ft.) at Malden; and they have contracted for 46 new cars (26 open and 20 box cars). They are also laying about six miles of 35 lbs. (Imp. Richards) girder rail, and three miles of 35 lbs. Worcester pattern (street) flat rail, and also about three miles of 25 lbs. T rail.

The North Woburn Street RR. Co. will purchase four open cars, and additional horses.

*Cambridge.* The Cambridge RR. Co. will soon rebuild five miles of track. They have a total length of 62 miles (single track).

*Fall River.* The Globe Street Railway Co. have procured ten new open cars; and are building a new car house  $50 \times 180$ , and a new barn  $50 \times 175$  feet.

*Newburyport.* The Newburyport and Amesbury Horse RR. Co. have their new stable and coach-house, etc., now in course of construction, and will equip their road with new cars—everything will be new throughout, and the old things will soon have passed away.

The same company petitions for the right to extend its road to Merrimac.

The Plum Island Street Railway Company organized on May 28th by the choice of the following-named directors, O. Dell and W. B. Ferguson, of Salem; Rufus H. Brown, of Peabody; C. C. G. Thornton, of Boston; Edward P. Shaw, and J. Frank Tilton, of Newburyport.

*Waltham.* The Waltham and Newton Street Railway Company are removing their track from side to centre of street for some distance.

*Worcester.* The Citizens' St. Ry. Co. will probably build and equip several new lines during the summer.

#### MICHIGAN.

*Grand Rapids.* The Street Railway Company of Grand Rapids are extending their present tracks three miles, as well as building three new lines.

*Muskegon.* The Muskegon Railway Company will add two open cars to their equipage forthwith, and will lay nearly three and one-half miles new track.

*Port Huron.* The Gratiot Electric Ry. Co. has been incorporated by W. F. Botsford; capital, \$250,000.

#### MINNESOTA.

*Duluth.* The Duluth Street Railway Company will make an extension of three miles to their tracks forthwith.

*St. Paul.* The St. Paul City Railway Company will construct two and one-half miles of cable railway this year, and extend their horse car lines from one to three miles (how much not yet definitely decided). They will also build a new barn, car house, etc., to accommodate 250 horses.

#### MISSISSIPPI.

*Columbus.* Captain Evans, of Birmingham, Ala., with a corps of engineers, has been running the lines of the Columbus Street Railway, on which work is to be pushed rapidly, and it is expected cars will be running by the end of August.

#### MISSOURI.

*Carthage.* The Carthage Street Ry. Co. will make an extension of two and one-half miles and put on two new cars.

*Independence.* The street car ordinance granting a franchise to D. P. Alexander to construct lines in any streets of the city for twenty-one years has been passed. It provides, also, that work shall be commenced within two months from the date of acceptance, and that the line shall be completed from the Southern Kansas depot to the intersection of Main street and Pennsylvania avenue within three months from the date of acceptance, and from the latter point to the Missouri Pacific depot within six months from date. The cars are to be run by water, electricity, cable or horse power, at a speed not to exceed ten miles per hour, fifteen hours a day, and at intervals not greater than sixty minutes.

*Kansas City.* The Kansas City Cable Railway Co. are building a new engine house and laying five miles single (two and one-half miles double) track, the road bed and engine house to be completed in August, when ten additional grip cars (twenty-passenger) will be operated. They have contracted for two 400 hp. engines and four set of driving machinery and three 200 hp. boilers. There will be sufficient power to operate twenty-five miles of road.

The Metropolitan Street Ry. Co. are extending their Fifth Street Cable line to Wyandotte and changing their Twelfth Street, Broadway, and Eighteenth and Main Street horse lines into cable.

The same company, now managing the Fifth Street Cable line, has had transferred to it by the action of the council the franchise of the St. John Street Cable line, formerly held by Captain T. A. Harris. The franchise covered by the ordinance is for a cable road on Highland avenue from Independence avenue to Fifth street, from Highland to Woodland, thence on Woodland to Lexington avenue to Bellefontaine, to St. John avenue, thence on St. John to the eastern city limits. The new line is properly an extension of the Independence avenue road which will be converted into a cable line, connecting with the Fifth Street cable at Walnut street. This, when completed, will make a line from the extreme eastern to the western city limits.

Contracts were let by the Kansas City Cable Company, May 2d, for a \$35,000 elevated depot, to be built at the western terminus of the Ninth Street line, between the present depot and the elevated railway depot. The building will be  $175 \times 125$ , thirty feet above the street.

The Kansas City and Rosedale Street RR. Co. have taken up their old track (which was single, with turnouts) and laid a new double track with Johnson girder rail. They will increase their cars to twelve and mules to ninety. The total cost of improvement so far has been \$20,000.

The property-owners on Sixth street and Broadway have petitioned for a cable road, to be built by the Metropolitan company. The petition was filed May 13. The cable is projected to supplant the horse-car line, and will extend south on Broadway to Twenty-third street.

The Citizens' Cable Railway has been organized by A. W. Armour and others; capital, \$750,000—half paid up.

*Lexington.* The Lexington Street Railroad intends to extend their road one mile.

*Lima.* The Lima Street Railway, Motor and Power Co., intend to extend their road as rapidly as practicable, and keep on equipping with new cars.

*St. Joseph.* The Citizens' Railway Co. will build some branches, change mules for horses, and change one mile of road to double track, with Johnson steel rail.

"The St. Joseph Circle Street Railway Company" is the registered title of the cable railway company with Messrs. Lillis & Co. at its head. After the granting of the cable franchise "the city was almost wild with excitement"—*i. e.* in its favor.



The Frederick Avenue Railway Co. are changing from narrow gauge T rail, single track, to standard gauge, double track. Road will be finished about August 1st.

The Union Railway Co. hope to have their one mile electric railway (Sprague system), at the north end of their line, in operation before the end of July. Their engine is 60 hp. minimum, and 90 hp. maximum.

*St. Louis.* The Southern Railway Co. will extend their tracks from Sixth and Market streets to Cass avenue.

The St. Louis Cable and Western Railroad Co. are building a new car house, to accommodate fifty-two cars; and between this and the middle of July, will receive the following additional equipment (a portion having already arrived):—twelve double deck passenger coaches, twelve summer cars, ten coaches, and eight grip cars.

#### NEBRASKA.

*Columbus.* The Columbus Motor Railway Co. filed their articles of incorporation, May 14. The incorporators are J. R. Meagher, R. H. Henry, Herman Oehlich, George Lehman, Leander Gerrard and John H. Kersenbrock, all of whom are prominent among the city bankers, capitalists and business men. The capital stock is \$200,000 with authority to increase to \$500,000, divided in shares of \$100 each. The object and purpose of the organization is the building of street railways in the city of Columbus, and a motor railway system to adjacent towns in Platte, Colfax, Butler and Polk counties. Two miles of street railway will be completed this season, and it is confidently expected that twelve miles of the motor line will be in operation before autumn. "Our people," says a local correspondent, "do not gush very much over their many public improvements, but when time is called at the end of the season the Flour city will not be the last under the wire."

The Omaha Motor Railway Company has filed articles of incorporation in the county clerk's office of Douglas County. It organizes with \$500,000 capital, \$250,000 to be subscribed and \$50,000 to be paid in before commencement of business. It proposes to construct lines in the cities of Omaha, Florence, town of Millard in Douglas County; Plattsmouth and Factoryville in Mass County; Fremont in Dodge County; Papillion and Bellevue, Sarpy County; Nebraska City, Otoe County, and on the country road west of Kensington, in the county of Douglas.

*Lincoln.* The Lincoln Street Railway Company will relay some of their track in paved district with double track and 33 and 40 lbs. flat rail. They contemplate building a mile or two additional road, and will probably add four cars to their equipment on line already in operation. This company now owns all the property and lines of the former "Capital."

*Omaha.* A motor line is to be built from Hanscom Park to Walnut Hill. Mr. Elliott has the contract. The Baldwin noiseless steam motor will be adopted.

#### NEW HAMPSHIRE.

*Laconia.* The Laconia and Lake Village Horse Railroad are about to build a stable and car-house.

*Manchester.* The Manchester Horse Railroad will build two and a quarter miles new road, and are about adding three cars and twenty horses.

#### NEW JERSEY.

*Jersey City.* The Jersey City and Bergen Railroad Company contemplate laying about two miles single track in Bayonne.

*Paterson.* The Paterson City Ry. Co. are about to add more cars and horses, and will build a new stable.

*Trenton.* The City Railway Company are building at present about three miles of track in the northern part of the city—through Warren, Bank, Willow and Spring streets—to be completed and in operation by August 1st. \*

#### NEW YORK.

*Albany.* The Albany Railway\* purpose extending their Madison Avenue line and their Clinton Avenue line, each

half a mile, and will put in double track on Pearl street for a distance of 700 feet. And they intend, in the near future, to "cable" their State street line.

The Watervliet Turnpike and Railroad Company are laying at present about a mile and a quarter of new double track, caused by the city repaving the street with dimension blocks.

*Astoria.* The Steinway and Hunter's Point RR. Co. (into which the Astoria and Hunter's Point RR. Co. merged April 13) have been authorized to use any power except "steam locomotive," and they intend to adopt either cable or electric traction.

*Auburn.* The Auburn City Railway Company are relaying a large portion of their five miles of road with new ties and stringers and bringing the track to grade. The original construction has been in the ground for some fourteen years, and on account of its wave-like motion has been called by many of its patrons "The Overland Route." The entire equipment of open and box cars are being overhauled, repainted, recurtained and put in first-class condition.

*Brooklyn.* The Brooklyn Heights R. R. Co., whose incorporation was mentioned in the May GAZETTE, has a capital stock of \$150,000.

The Covered Tube Cable Railroad Co. has leased Montague Hill for \$10,000 per annum. This covers a part of the route of the Heights R. R.

The Union Elevated Railroad Co. is putting up its superstructure rapidly.

The Kings County Elevated Railroad Co. has nearly 1,000 men at work in the foundations for the columns.

The Cross Town Railroad Co., has purchased the Greenpoint and Calvary Cemetery Railroad and will replace the long cars with bobtails.

The Brooklyn, Bushwick and Queen's County Railroad Company will build about a mile and half of new track. The North Second Street and Middle Village Railroad is now owned and operated by this company, who bought it when sold under foreclosure.

The Grand Street, Prospect Park and Flatbush Railroad Company had their entire property sold under foreclosure of second mortgage April 27th last, and the road is now leased from the purchaser, and operated by the Brooklyn City and Newtown Railroad Company.

The cable line on Park avenue has proved so successful that the original intention is to be carried out, and the line extended to Fulton Ferry. This is the Johnson system—a spur wheel on the car gearing with a cable of flat links. The Johnson system of cable will be adopted for the Brooklyn bridge extension.

The senate has passed the bill authorizing the construction of an electric or cable railroad on Montague street with the consent of the local authorities and a majority of the property owners.

At the meeting of the trustees of the Brooklyn Bridge, May 18, plans were adopted by which a complete change will be made in the method of switching cars and receiving and discharging passengers. The whole of the addition to the bridge which was lately built over Park Row is to be used for passengers, and no cars or locomotives will be permitted upon it. The plans were drawn by Charles E. Emery, an expert engineer, and have been accepted by a unanimous vote of the trustees. Messrs. Howell, Clarke and Macdonnell were appointed as a committee to carry the alterations into effect at once, and Mr. Emery was appointed consulting engineer on the work. Bridge Engineer Martin will have the control of the work and the making of the contracts, as in the past.

*Catskill.* A street railroad is to be built in the village.

*Ilion.* The Frankfurt and Ilion Street RR. Co. are about to add a new car and new rails.

*Jamaica.* The Brooklyn Annex Street RR. Co. has been organized to build a line from Brooklyn to Jamaica Bay.

*Long Island.* The Flushing and College Point Electric Street Railway Company has filed articles of incorporation at Albany. The capital stock is stated to be \$150,000, divided into 1,500 shares of \$100 each. The company will operate

\* "The Albany Railway" is the company's corporate name; the word "company" forms no part of their title.

an electric railroad, says the *Electrical World*, through the villages of Flushing and College Point. The length of the road will be six miles.

*Niagara Falls.* The New Foundland and Suspension Bridge Railway Company will make about a mile and a half extension—to new Racing and Fair Association Ground. They are also putting on additional cars and horses.

*New York.* The Fulton Street Cross Town Railroad Co. has been incorporated by C. N. Day, of Brooklyn, and others with a capital stock of \$25,000.

The new stations on the Sixth Avenue Elevated road are nearly finished. They have the general appearance of the old ones.

The Pennsylvania Railroad Company has under consideration plans for double-decked ferry boats to land passengers on the New York side of the North River in an elevated waiting room, West street to be crossed by a bridge. The Manhattan Elevated Railway Company has agreed to run a branch to connect with the bridge.

*Oneida.* The street railroad will be in operation shortly.

*Rochester.* The Rochester City and Brighton RR. Co., who operate about thirty-seven miles of single track, are about building a barn to hold 100 horses and a car-house for thirty cars. They also contemplate an extension of about two-and-a-half miles single track.

*Rome.* The street railway will soon be under construction; the Johnson girder rail will be used. The cars are being built by the John Stevenson Co., of New York. M. Schiller is the engineer.

*Syracuse.* The Geddes Street Railway Company have not yet commenced laying any track, but intend doing so this summer.

The Genesee and Water Street RR. Co. will put down a new switch and relay a portion of track.

The Fifth Ward Street RR. Co. are about to build a barn 60x140 ft., adding a new boiler and engine, 15 hp., to clean their own horses, cut their own hay, grind feed, etc.

The People's Ry. Co. has been incorporated with a capital of \$300,000 to build a six-mile track forthwith, with extensions subsequently, by Daniel Jones, of Brooklyn, and others.

*Troy.* The Troy and Lansingburgh Street RR. Co. are increasing their street railway facilities.

*Yonkers.* The Common Council has adopted a resolution giving permission to the Yonkers Rapid Transit Railway Company to use and occupy for its railway so much of the streets and avenues of the city as are designated upon a map submitted to the Common Council May 24, 1880, outlining the proposed route. The road is to run from Getty Square to the North Yonkers station of the New York City and Northern Railroad. An arrangement has been made for the railroad company to operate the line, which will be completed forthwith.

#### NORTH CAROLINA.

*Asheville.* The Asheville Improvement and Street RR. Co. will build a street railway.

*Winston.* The Winston Electric Light and Power Company, recently formed, is about to build an electric railway.

#### OHIO.

*Ashtabula.* John N. Stewart, owner and manager of the Ashtabula City Railroad, contemplates building extension, in the near future, to the Public Garden, on the lake front. This road connects the towndepots and harbor; fare, 10c. The city is four miles from Lake Erie, and at the harbor there are about 5,000 operators.

*Canton.* The Canton Street Railway Company intend laying three-fourths of a mile soon, and are about adding a couple more cars.

*Cincinnati.* The Cincinnati Street Railway Company are now constructing about six miles cable railway, and expect to construct about twelve miles of electric railway during the later season.

The Mt. Auburn Cable Railway Company hope to have half their line finished and in operation by August 1, and the other moiety of their cable road completed by the end of the present year.

*Cleveland.* The Brooklyn Street R. R. Co. will soon add ten new closed cars to their equipment.

The East Cleveland RR. Co. are building twelve open cars in their own shops; and are building a twenty-car house, and will construct six box cars during the summer. One of their routes is to be extended one mile, and a second track laid on a mile of another route.

The Woodlawn Avenue & West Side Street R. R. Co. are laying a mile of the Richards rail, and building a large barn and car house and repair shops; also constructing two miles of new track, and building eight new cars—four box and four open.

The drivers on one of the street railways in this city recently threatened to strike because "They won't be bossed by a nigger," who had been placed as conductor.

*Dayton.* The Dayton Street RR. Co. have recently added one new car and twenty-one head of live stock, and they will purchase another new car during the summer.

*Mansfield.* The Mansfield Electric Street Railway Company has been incorporated by M. Van Rensselaer and others, with a capital stock of \$75,000. The company puts in the Daft system for its road.

*Pomeroy.* The Pomeroy and Middleport Street Railroad Co. has been organized.

*Sandusky.* The Sandusky Street Railway Co. are about to make an extension of two miles to the Ohio Soldiers and Sailors' Home in the suburbs. They will make further extensions in the city next year.

*Tiffin.* The Tiffin Street Railroad Co. has been incorporated by P. D. Adams and others. Capital, \$16,000.

*Toledo.* The Toledo Consolidated Street Railway Co. are laying two miles of double track and building a new stable and two car houses.

The Metropolitan St. Ry. Co. will build an extension of over half a mile to connect their line with the Union depot.

#### OREGON.

*Portland.* A street railroad is to be built between East Portland and Sellwood. Sellwood real estate is therefore booming.

#### PENNSYLVANIA.

*Allegheny.* The Federal Street and Pleasant Valley Passenger Railway Co. are building a half-mile extension suburbs-ward.

The People's Park Passenger RR. Company are going to lay 1,600 feet additional track.

*Chester.* The Chester Street RR. Company have just opened a new line of two miles to Twenty-fourth Street.

*Harrisburg.* The Harrisburg City Passenger Railway Company intend to relay a mile of their track with the Johnson girder rail (fifty-two pounds to the yard.)

*Lancaster.* The Lancaster City St. Ry. Co. are now extending their road, increasing their equipage, and building a car-house and stable (200x50 ft.)

*Philadelphia.* The People's Passenger Railway Company contemplate extending their tracks about two miles, from Eighth and Dauphin streets to Lehigh avenue, along Lehigh avenue to Fourth and thence to Norris street.

*Pittsburgh.* The South Side Passenger RR. Co. (who have two and a half miles double track in operation) are now laying an additional half mile of double track to connect with the Pittsburgh & Birmingham RR. Co's line at their stables, the former company having been purchased by the latter.

The Citizens' Passenger Railway Co. are operating the Transverse RR. Co.'s line of six and one-third miles in addition to its eighteen miles of track.

The Pittsburgh Traction Company, with a capital stock of \$2,500,000, will construct a cable street railway along Fifth avenue, from the lower part of the city to the East End. The permanent way will all be iron and steel, imbedded in concrete. The cable will be one and three-eighths inch and of steel wire.

*Scranton.* The People's Street Ry. Co. are anxious "to get something to take the place of horse power."



## RHODE ISLAND.

*Woonsocket.* The Woonsocket Electric Railway is now in course of construction.

## SOUTH CAROLINA.

*Charleston.* The Charleston City Railway Co. contemplate extending their tracks about one mile in the southwestern part of the city.

## TENNESSEE.

*Athens.* J. L. Young has the contract to build the street railroad for \$4,000.

The Elmwood Street Railroad Co. has been organized.

The Fountain Head Railroad Co. has been incorporated by J. H. Cruze and others. It will be a motor line.

The West Nashville Passenger Railroad Co. has been incorporated by E. T. Noel and others.

A motor line is to be built by a company organized by John Libyett, Wm. Morrow and others.

*Jackson.* The Jackson and Suburban Street Ry. Co. has been organized. President, C. H. Heath, of Sioux City, Iowa; Secretary, R. B. Crawford, of Wayne, Neb. Capital stock, \$50,000.

*Knoxville.* The Knoxville Street RR. Co. will make an extension of three quarters of a mile.

The Market Square Street RR. Co. will also extend their track three quarters of a mile.

*Memphis.* The Citizens' Street RR. Company (with which the Memphis City RR. Co. was consolidated January 1st last) are laying six miles of new track with the Johnson steel rail (38 lbs.)

*Nashville.* The McGavock and Mt. Vernon Horse RR. Company are erecting the new Union stables, and replacing old iron rails with Johnson 30 and 38 lbs. rails, and adding two miles of branch tracks. They are anxious to change one of their lines (three miles double track with from 4 to 5½ per cent. grades) to "some suitable power system."

The North Nashville Street Railway Company has been incorporated by J. G. Jones and others.

## TEXAS.

*Brenham.* The Brenham Street Railway is to be sold. S. Pampell is President.

*Dallas.* The Dallas Consolidated Street Railway Company hope to make about four miles of extensions this year, and will make improvements in present tracks, stables, cars, etc.

*El Paso.* The El Paso St. Railway Company will build a mile of new road this summer.

*Fort Worth.* The Fort Worth Street Railway Company contemplate building another line of road.

*Galveston.* The Gulf City Street Railway and Real Estate Company have had a petition before the city council for the past couple or three months, asking the right of way over certain streets, in order to complete a triple belt route, and for which all the materials has been on hand some time.

*Greenville.* A street railway is to be built.

*Paris.* Iron is en route from Johnstown, Pa., to build a mile and a half flat rail (32 lbs.)

*Sherman.* The Sherman City Street Railway Company are extending their track about 1¼ miles.

*Waco.* The Waco Street Railway Company are building brick stables and office, to cost sixteen thousand dollars.

## WASHINGTON TERRITORY.

*Seattle.* The Seattle Street Railway Company intend making improvements and extensions, not yet definitely decided upon. They are investigating electricity as a motive power.

## VERMONT.

*Burlington.* The Winooski and Burlington Horse RR. Company are constructing three miles of new road.

## VIRGINIA.

*Norfolk.* The Norfolk City RR. Co. intend to replace a large portion of their track with new 43 lb. steel rails, and contemplate a short extension of line to gain more convenient terminus.

*Richmond.* A contract has been closed by the Sprague Company with the Richmond Union Ry. Co. to run the road by electricity. The service will include forty 16-foot cars, each equipped with two 7½ hp. motors, so as to be absolutely free from danger of any breakdown. Overhead conductors will be used, and there will be in all about thirteen miles of track. The road is to be running this summer, and the work of electric construction has already begun.—*The Electrical World.*

The Manchester RR. and Imp'vt. Co. will build a st. ry. The Metropolitan Quick Transit Co. has been incorporated by E. Y. Cannon, T. C. Williams, and others. Capital, between \$100,000 and \$600,000. Steam or electric motors will be adopted, and new bridges will be built over the river, as the present ones are not strong enough to carry the motors.

## WASHINGTON TERRITORY.

*Tacoma.* The Tacoma Street Ry. Co. will use a noiseless steam motor on the road they are now constructing.

## WISCONSIN.

*La Crosse.* The La Crosse City Ry. Co. will make an extension of about a mile this year.

*Milwaukee.* The Milwaukee City Ry. Co. are progressing with the erection of their new barn and car house, and their new stable, when completed, will accommodate two hundred horses, and they will have storage for twenty-five cars. They will add seven new cars to their equipment this season.

The Milwaukee Cable Railway Company has been organized at Milwaukee to build a line of cable road from the centre of the city to the western limits.

The Milwaukee and Wauwatosa Street Ry. Co. has been incorporated by S. C. West, John McCallum and others. Capital, \$100,000.

## CANADA.

*Belleville, Ont.* The Belleville Street Ry. Co. will build a slip switch midway from the first regular switch to the railroad station to make closer connections with trains.

*London, Ont.* The London Street Ry. Co. are doubling their Dundas street track throughout, and replacing their iron rails with steel on all their tracks. They are also adding a new stable 40x80 feet.

*Quebec.* The Quebec Street Ry. Co. have relaid about two-thirds of their track with steel rails, and they intend to put steel rails on the remainder this summer.

*St. Catharines, Ont.* The St. Catharines, Merriton and Showell Street Ry. Co. are equipping their line with the Van Depoele Electric Railway system and hope to have it running in September.

*Toronto.* The Toronto Street Ry. Co. will erect a new stable and car house and make further extension of tracks.

*Windsor.* The Windsor Electric Street Ry. Co. will build another car and will put on steel T rails (20 or 25 lbs.)

## UNITED STATES OF COLOMBIA.

*Bogota.* The Bogota City Ry. Co. have the monopoly (for thirty years) of the city of Bogota, the capital of the United States of Colombia, which has a population of 120,000, and they contemplate considerable extensions through the various streets of the city as soon as advisable. They have now four miles of double track in operation. The head office of this company is over 2,500 miles (as the crow flies) away from the city it monopolizes, viz., at Room 20, No. 1 Broadway, New York. George H. Stayer is president, and Frank W. Allin secretary and vice-president.

## Books, Periodicals, Pamphlets, etc.

*Railway and Tramway Equipment:* Dynamos and Motors. The Bentley-Knight Electric Railway Company, 115 Broadway, New York, have issued a new illustrated pamphlet, by the De Vinne Press, enumerating the merits and peculiarities of their system of electric railways. It also contains tabulated comparisons between the costs and expenses of horse, cable and electric railways; and the book is as instructive as it is elegant; or, rather, the paper is good, the printing is better, and the information it contains is the best.

### Business Notes.

THE Car Track Friction Appliance Co. will furnish the new cars now being manufactured by the John Stephenson Company for the Vine street cable; also, the Walnut Hills Division of the Mt. Adams and Eden Park Inclined Railway (cable) of Cincinnati, O., with their "Reliable" sand boxes. They have been in use on the last named road since January.

THE offices of the Boston Consolidated Street Railway Company are on Tremont Row, corner of Pemberton Square. The officers are: Charles E. Powers, president; Moody Merrill, treasurer; John H. Studley, Jr., assistant treasurer.

INVENTORS and patentees of street railway appliances will do well to put themselves in communication with the New England representative of THE STREET RAILWAY GAZETTE, whose office is at 19 Tremont Row, room 4.

A NEW street railway, the extent of which has not yet been determined, and a passenger railway up a hill, to be operated by a stationary engine, and with two passenger coaches, will be built by C. H. McMaster, Dubuque.

COFFIN, DEVOE & CO., 176 Randolph street, Chicago (F. W. Devoe & Co., N. Y.), desire special attention to their coach and car colors ground in Japan, and in oil. As stated in their advertisement in this issue, they have fine varnishes, fine brushes and every requisite for painting department.

THE SPRAGUE ELECTRIC RAILWAY AND MOTOR CO. (16 and 18 Broad street, New York) are making important arrangements to increase their manufacturing facilities. They are about to enter into a contract with the Edison Machine Works at Schenectady for the construction of the Sprague Standard machines. The special application of the motors to the various arts and mechanical appliances will be done at the Sprague experimental factory (510 W. 30 street) in New York city, which is being equipped with the best special tools, under the immediate supervision of the company's electrician.

J. M. JONES' SONS, Troy, N. Y., recently shipped four closed cars to the Buffalo St. Ry. Co. Also a number of cars to the South Boston Railroad Co.

THE Wilson brake shaft has been adopted by the Troy and Lansingburgh R. R. Co. (N. Y.) on all their cars.

THE LANE & BODLEY CO., Cincinnati, have secured the contract for the complete engine house plant of the Vine Street Cable Railway, including a pair of 26"x54" Corliss engines, three tubular boilers, 72"x18 ft., with Murphy furnaces, and two sets of cable driving and tension machinery. The plant will be arranged on the ground floor—quite an unusual disposition—and will make an exceedingly attractive machinery display. The successful bidders have excellent facilities for this heavy class of work; they were among the earliest possessors of the gear moulding machines, and have acquired an enviable reputation for their gearing and heavy castings. This is one of the few shops prepared to furnish, from their own establishment, engines, boilers, shafting and heavy gearing.

THE Bidwell Electric Railway and Power Co. continue operating their experimental line at the end of Madison street, Chicago—on the shore of Lake Michigan.

THE Metropolitan Street Railway Co., Kansas City, have adopted the Edison incandescent system for lighting purposes.

Pullman's Palace Car Co. have sold eight more closed cars to the Metropolitan Street Railway Co., Kansas City; sixteen feet long, mahogany finish. This is Pullman's second order from the same company. President Walsh, of the Citizens' Railway (now being converted into cable) at St. Louis, has also ordered some very fine Pullman cars, finished in mahogany; length thirty-five feet—there being ten feet of space at the forward end, to be arranged for the gripman. The trucks are of Pullman's latest design, with equalizing springs.

E. M. BENTLEY & W. H. KNIGHT,

PATENTEES.

RHODE ISLAND LOCOMOTIVE WORKS

CONSTRUCTORS.

# Bentley-Knight



# Electric Railway Co.

CONTRACTORS FOR THE

EQUIPMENT OF RAILWAYS AND TRAMWAYS,

Using either Elevated, Surface or Underground Conductors.

*DYNAMOS AND MOTORS OF EVERY VARIETY.*

ESTIMATES FURNISHED ON APPLICATION.

115 Broadway, NEW YORK CITY, U. S. A.



# The Street Railway Gazette.

VOL. II.

CHICAGO

JULY, 1887.

NEW YORK

No. 7

## American Cable Railway Construction.

BY AUGUSTINE W. WRIGHT.

PART I.—Continued from page 89.

That enabled the grip to pass under the depression pulleys.

The grip used on the Clay Hill road differs from many in having a vertical action, so that it can be lowered to grasp the cable, and then raised to clear the carrying sheaves at any point. Figs. 11, 12 and 13 illustrate it, and show that it is fixed to the dummy by the sides through which the large screw works. The large screw is hollow, and is used to raise and lower the grip. It is operated by means of the lower hand-wheel, and is set at a height not to strike anything in the tube when the car is in motion. The upper

guide wheels and the jaws, but it is not in contact with the latter. By turning the lower hand-wheel the grip is raised to its proper level, so as to clear the lower pulleys and other obstructions, and when it is desired to grip the rope an extra turn is given to the upper hand-wheel, which raises the wedge still higher, bringing the jaws in contact with the rope and forcing the guide wheels back on their springs. When the jaws are brought firmly on the rope, of course the grip and the dummy to which it is attached moves with the rope with the same velocity; but this momentum is acquired quite gradually, for as the guide wheels are tightened on the rope, the dummy gradually acquires the momentum of the rope until the gripping jaws securely hold the rope.

All this is performed with great ease and rapidity by the man in charge, from the floor of the dummy. An other use to which the heel of this grip is put is for braking the

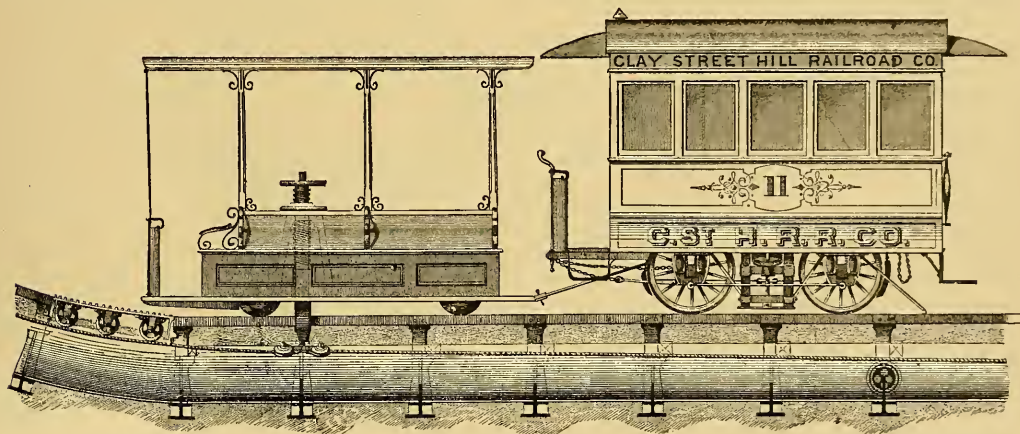

FIG. 14.

hand-wheel works on a screw cut in the end of a rod, which passes down through the hollow screw, and is connected to a slide working in the shank of the grip, so that, according to the way the upper hand-wheel is turned, the slide is raised or lowered. At the lower end of this slide is a wedge-shaped block, having the thick edge down, and two frames which slide on the heel of the shank, are moved in a horizontal direction by this wedge. Attached to these sliding frames are jaws which grip the rope, and small wheels which hold the rope in position, and guide it between the jaws. These guide wheels have rubber springs behind them which keep them pressed forward a little in advance of the jaws; and after the sliding frame and jaws are opened by lowering the wedge, by means of the upper hand-wheel, the grip is lowered over the rope by means of the lower hand-wheel, working on the big screw, and the rope is seized by closing the sliding frames, which brings the guide pulleys on each side of the rope. The moving rope runs freely between the

dummy on a steep grade, in case of necessity. For this purpose it is brought up in contact with the square shoulder of a lateral timber immediately above it, forming part of the conduit. This use is only resorted to in the event of an emergency, the ordinary brake usually sufficing.

When the grade of the road changes suddenly upwards, pulleys have to be used, as before stated, to keep the rope down. These are necessarily of small diameter, and are illustrated in fig. 14, which is a side section showing tube, upper and lower carrying pulleys, grip, dummy and car. Upon the latter will be noticed a track brake, between the car wheels. This is applied by means of a screw, forcing it down on the track rail with sufficient power to raise or empty car.

The large wheel which sets the rope in motion, consists of a series of jaws hinged together in the middle, and having spurs that rest on the circumference of the wheel. When the rope presses on the jaws, they grip it; as soon as the

pressure ceases, they open automatically. See figs. 15, 16, and 17.

Obviously one of the most important items of expense in the running of a road of this character is the wear and tear of the wire ropes used in hauling the cars, and one of the great drawbacks to the successful working of the system would be the mutilation or breaking of the rope during the hours of business, and the detention of travel caused thereby; hence the most careful consideration had to be given to the life of the rope—to the immediate detection of any weakness, and to its immediate repair. Consequently all the sheaves and rope pulleys employed are of as large diameter as possible. The rope is made to lead in a true line into the grooves thereof. As few turns as possible are given to the rope. It is conducted to the drum in full view of the engineer, so that he can inspect it. Tell-tales fixed at a point where the rope enters his room, automatically sound an alarm if a broken strand passes.

The engine room, offices and car house of the Clay St. Hill Line are located near the summit of the hill, 3,300 feet distant from the eastern terminus, and 307 feet above it. The engine is in the basement of the building, 15 feet below the sidewalk in the street. The building is 68x68 on ground, and being at the intersection of two streets, light and ventilation is obtained from both the north and east sides. Steam is supplied by two boilers, 16 feet by 54 inches, having 46 tubes  $3\frac{1}{4}$  inches diameter. The furnaces are supplied with Morton's smoke consuming fire doors. The chimney is 80 feet high.

There were two horizontal engines, 14x28 inches, made by the Delaware Motor Co., and furnished with the Ryder cut-off. The piston speed of the engine is 532 feet per minute, when the rope moves six miles per hour. The driving pulley is 8 feet in diameter. Angle sheaves the same.

In the engine house there is provided a take-up arrangement for the rope, by means of which the stretch of the rope is taken up. This is a wrought iron bed sixty feet in length, extending from the grip pulley frame toward the angle sheaves. On it is placed a sheave 8 feet in diameter, around which the cable passes; this is moved backwards or forwards as may be rendered necessary by the length of the wire rope.

The rope leaves the track around an 8 foot sheave, then passes half around the double grip pulley, thence half around the 8 foot rope sheave of the "take-up," back to the grip pulley; half around it, thence out of the engine house over the angle sheave, down the tube. By this arrangement, if the take-up sheave is set back 50 feet on the bed, 100 feet of rope is taken up.

The wire rope was made from crucible steel wire; six strands of nineteen wires each, .062 inch diameter were used, whose tensile strength was 160,000 pounds per square inch. Its average service was 20 months. The passenger cars seated 14 people. Its weight was 2800 pounds. It was provided with ordinary brakes applied to the wheels, and also a brake between the wheels pressing virtually upon the rails, 28 inches long, and worked by a screw from the platform of the car. It is powerful enough to lift the car off the track, when the latter is empty.

The dummy, as the car is termed that carries the grip, is fitted with seats for 18 passengers. All equipped it weighed 2200 lbs. It is supplied with ordinary wheel brakes, and in addition thereto, other brakes worked by the foot, acting in a wheel attached to a right and left hand screw, actuating nuts which spread apart levers having at their feet shoes that press, at an angle of  $45^\circ$ , inward on the rail. The grip used on this line could also be utilized as a brake by screwing it up tight against the inside of the smooth surface covering the tube.

We are indebted to the *Mining and Scientific Press* of July, 1885, for the following account of

#### THE CALIFORNIA STREET ROAD:

One of the best built and equipped cable roads in this city, San Francisco, is the California street line, the third one built here. The company was organized in 1876, Hon. Leland Stanford being the moving spirit in the enterprise.

In thoroughness and completeness of details, the work on this road is of the first order. Plans for the work were begun in March, 1877. The work was soon mapped out, and in the following month orders were sent East for the rails. These rails were made from the patterns of Henry Root, constructing engineer of the road, and were designed to enable cars to run without the jolting experienced on many of the other street railroads. The top looks like that of a "T" rail, and the "fish-joint" is used. The rails are of steel made by the Cambria Works, Johnstown, Pennsylvania. The roadbed consists of a solid mass of concrete cement, through which runs the channel containing the rope. The ribs of this channel are composed of "T" rail iron, bent in the form of a "U." This series of ribs is enclosed by cement, which is filled up to the rail, and forms a perfectly solid body as wide as the track itself. The cross-pieces are of iron, and the space between the rails is paved with stone blocks, over which liquid cement is poured. As the blocks rest upon the foundation cement, the whole structure is knit together, and forms one solid mass. No wood is used in the construction of the work, and only the best quality of

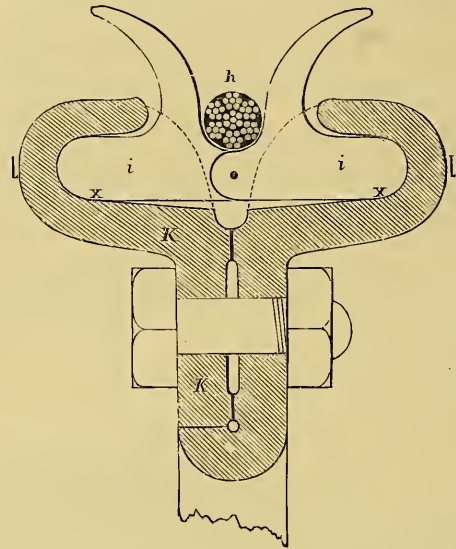

FIG. 15.

iron and steel has been admitted. There is thus seen to be an almost indestructible roadbed, as strong as stone itself, and containing nothing liable to decay. Ground was broken July 5, 1877, and the last rail was laid December 8th. During the time of this extension work, from 250 to 300 men were employed.

On this road they have 12,000 feet of double track, and it passes in that distance over two elevations, the heights being 265 feet and 235 feet above base respectively, the valley between being 125 feet above base. The gauge is  $3\frac{1}{2}$  feet, same as the Clay street. This road, like Clay and Sutter streets, has been extended beyond the length of its original construction, which was 8,800 feet, and which was constructed in a very substantial manner, the tube being formed of worn-out 65-pound rails and surrounded by concrete. The engine-house is located in a valley about midway between the termini of the original section. Some of the grades on this line are quite heavy, there being a rise of 67 feet and 75 feet respectively in the distance of  $412\frac{1}{2}$  feet. This is the heaviest grade in San Francisco, except one block on the line of the Presidio Railroad, which has a rise of 78 feet in the same distance. This company uses a heavier rope than the other lines in this city, viz., 4-inch circumference, and the driving pulleys are on the same plane as the rope, and situated under the street.



The engine and machinery are placed in an excavation at the Larkin and California street crossing. This excavation is 31 feet deep below the surface of the street, 110 feet long and 30 feet wide. The engines are placed under the building and sidewalk, while the driving gear and other machinery is under the centre of California street. The engines, of which there are two, were made by the Hope

Kearney street it passes around a large wheel in a loaded car standing on a track inclining at an angle of about 30 degrees. This car, by falling, takes up any slack that may be in the rope. The rope also goes over a similar wheel before it goes out, taking up whatever slack there may be there. There is also a loaded car at each end of the line, so that by all these arrangements 100 feet of slack can be taken up automatically.

This company is reconstructing the road-bed on Fillmore street west to Cemetery avenue, filling it in with cement the same as the balance of the road.

The building of the company at the corner of Larkin and California streets is three stories high and fronts 70 feet on Larkin and 80 on California. It contains the office of the secretary, superintendent and other officers. Tracks run all through the building on every floor, and elevators are used for transferring the cars from one story to another. The floors are cement, having gullies in which the water is collected when the cars are washed.

Like other cable roads, this one had a marked effect on the property near its line of roadbed. Blocks of land increased largely in value, and along the road the finest residence property in the city is located. The hill property was before in little demand, but since this road has been running, it is now more valuable for residence purposes than any in San Francisco. Many palatial residences have been built on the hill, which is locally known as "Nob Hill." The line is largely patronized, and has been very profitable to its owners. The road is a pleasant one to ride over, the view from the summit of the hill being very fine, and many persons ride out to the cemetery and back on these cars for a pleasure trip.

And street car riding, like other soothing habits, becomes a very pleasing habit, especially on cars propelled by cable.

*(To be continued.)*

The engine in use at the main station of the Brooklyn Cable Company's road is of the Harris-Corliss pattern, built by Mr. Harris of Providence, R. I. It is rated at 209 horse-power, making 60 revolutions per minute. Attached to the engine is a fly-wheel 20 feet in diameter and weighing 25,000 pounds; the cylinder is 24x48 inches with self-packing valves, and the main shaft 13 inches in diameter. The gearing is arranged two to one from the main shaft to counter or intermediate shaft, and from that to the driving-drum this gear is two to one again. The gears are 16 inches face with 6-inch pitch, and driving gears 13-inch face and 5½-inch pitch. There are three coils around the driving-drums

of the cable. These drums are a little over 12 feet in diameter, making between 16 and 17 revolutions per minute. When they are speeded to their capacity, it is calculated that 20 revolutions can be made per minute. The cable is double and each is ¾ inch in diameter, and at intervals of 8 inches is secured by catches. It is about 3 miles in length. The cable passes from the street over the 2 driving-drums and then over a tension-carriage. A wire rope with a weight of 2,000 pounds is attached to the tension-carriage, passing over 2 pulleys.

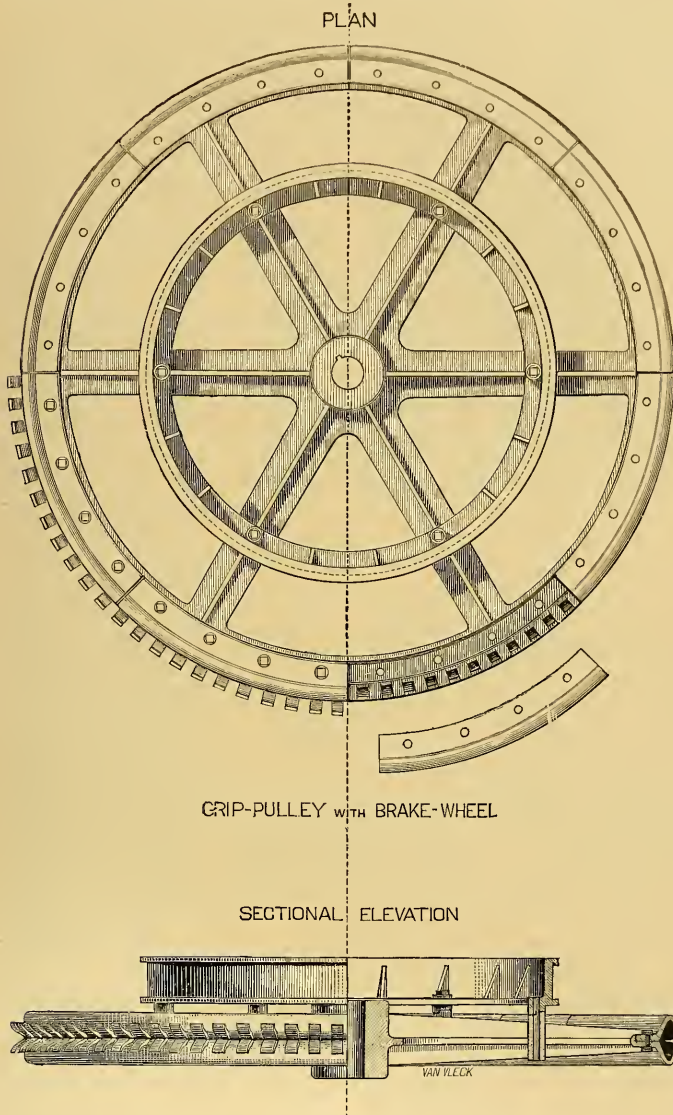

FIGS. 16 AND 17.

Iron Works of this city. They are of 250 horse-power each, and can be used either separately or together.

One is sufficient to do the entire work, and one will be kept in reserve to be used in case of accident to the other. They are made to run at 90 revolutions per minute, if required, giving a speed of about 8 miles per hour. Complete, the engines weigh over 60 tons. All the bearings are brass. The engine cost over \$15,000.

Beneath the street is the machinery and wheels over which the wire cable passes. As the rope comes in from

### Ries' Electric Railway Brake.

Mr. Elias E. Ries, of Baltimore, claims to have invented an efficient method of applying or graduating the flow of the electric current to the brake apparatus of a train or car, so as to prevent the sudden application and shock that has hitherto been unavoidable in all electric brake appliances. Efforts have been made by many, from time to time, to utilize electricity for operating railway friction brakes, as its acknowledged superiority, from a practical and economical point of view, peculiarly adapts it for this class of work. These attempts have, however, in many cases been unsuccessful, mainly because of the sudden strain and concussion upon the moving portions of the brake mechanism and wheels, and the great abruptness and severity with which the brakes were applied when the circuit leading to the brake device was closed. In other words, that most important quality of the current so valuable in this and in other applications of electricity—its great speed and rapidity of action—proved most detrimental in the present instance, simply because it prevented that easy and gradual control of the current essential to success. Great difficulty was also experienced in properly regulating the amount of braking force exerted by the devices heretofore employed, and for varying this amount to suit the different requirements met with in practical work.

The Ries' system, it is claimed, overcomes these difficulties in a very simple and effective manner by the employment in the brake circuit of an automatic circuit-closing device provided with two independent levers. One of these levers is under the control of the engineer, and determines the extent to which the brakes shall be applied, while the other is automatic in its action; and when the first-mentioned lever is moved, operates to transmit and gradually increase the flow of current to the electro-magnetic brake devices, until they have reached the strength determined by the position of the first-named lever. By this means the brake devices are not only protected from sudden strain, but when the speed of the transmitting lever is once properly adjusted, the brakes can be applied and the train brought to a standstill within the shortest possible space of time.

Figure I is a sectional elevation of the inclosing-case of the regulating and governing apparatus, giving a general view of the interior and showing the connections when it is intended to be used to regulate the current from a primary or a secondary battery. Fig. II is a sectional end elevation of the same with the cover and switch-lever in place. Fig. III is a view similar to fig. I, except that this view shows the interior connections when it is intended to regulate the current transmitted to a derived working-circuit from a main working-circuit, or to transmit the direct current from a suitable generator to one or more translating devices that require a gradual application of the current. Fig. IV is a

detail sectional view of the automatic regulating and governing devices. Fig. V is a front elevation of the apparatus, showing the switch-lever and the arrangement of circuits when used in connection with the cells of a secondary battery. Fig. VI is a diagram view of a secondary battery, illustrating the method in which the cells are connected to the binding-posts leading to the upper row of contacts of the apparatus. Fig. 7 is an enlarged sectional view of the dash-pot piston and its openings.

Referring to the letters of reference, *A* is an inclosing-case containing the circuit-closing mechanism. This case is provided with a cover or door, *a*, and may either be made of cast-iron, or, if desired, of insulating material—such, for instance, as hard rubber. A shaft, *B*, is supported in insulated bearings *b b*, fixed in the front and back of the case, respectively, and loosely mounted on this shaft is a contact-lever, *C*, having contact-surfaces *c c'*, one at each extremity of the lever. These contact-surfaces are adapted to make electrical contact with two independent series of contacts, *d d'*, placed, respectively, in the paths of the contact-surfaces *c* and *c'*. The contacts *d d'* are secured to a plate, *D*, of insulating material, or are fixed directly to the rear wall of the inclosing case, if the latter is formed of non-conducting material, as before stated. The upper series of contacts connect, respectively, with a corresponding number of binding-posts, *U U'*, etc., arranged along the curved top of the case *A*, and these in turn are connected with a secondary battery.

Suitably secured to the interior of the case *A* is a curved solenoid or helix, *F*, whose soft-iron core *f* is firmly fixed to the contact-lever *C* at or near its lower extremity, and is curved to correspond with the shape of the interior of the solenoid, as shown in the sectional view, fig. IV. Directly opposite the solenoid is a dash-pot, *G*, whose function is to regulate the motion and prevent the too rapid entrance of the core *f* into the solenoid when the latter is energized. To this end the dash-pot is provided with a piston, *g*, having two valves or openings therein of different size and opening in opposite directions, as shown at *g<sup>1</sup>* and *g<sup>2</sup>*, fig. 7. The interior of the dash-pot cylinder is filled with a suitable liquid—such as glycerine—and when the piston *g* is drawn out by the action of the solenoid, the liquid escapes through the smaller opening, *g<sup>2</sup>*, into the rear of the cylinder. The opening in this valve can be regulated by an adjustable tapering set-screw, as shown, and as the space of time in which the solenoid can draw the piston to the other end of the dash-pot is determined by the size of the opening in the piston, and consequently by the length of time required by the liquid to pass from one side of the piston to the other, it will be seen that the motion of the lever *C* over the series of contacts *d* and *d'* is not only very regular, but the time occupied by it in doing so can be accurately adjusted by regulating the size of the opening in the piston. When the current passing through the sol-

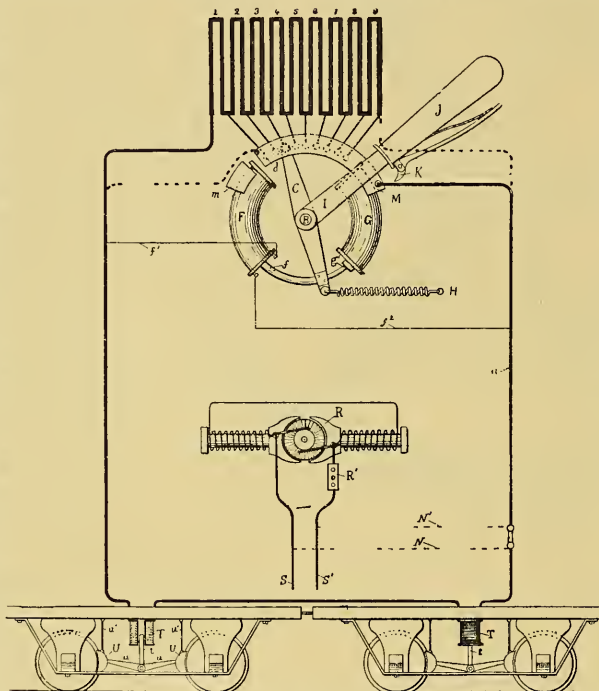

FIG. 8.



enoid is interrupted, the contact-lever and the various parts connected therewith are restored to their normal position, as shown in figs. I and III, by the action of the spiral spring *H*, the liquid in the dash-pot in this case passing through the larger valve.

Although the dash-pot cylinder is shown curved, in order to better harmonize with the form of the inclosing-case, it is clear that any other form of cylinder may be used, or other substitute—such as air—employed therein without departing from the spirit of this feature of the invention.

Near the front end of the shaft *B* is pivoted a switch-lever, *I*, having a handle, *J*, of non-conducting material, and a sector-pawl or ratchet-lever, *K*, designed to enter notches *k*, placed at intervals along the arc formed by the top of the case *A*. A projecting arm, *i*, extends backward from the lever *I*, and, being in the path of a similar projection, *e*, on the contact-lever *C*, (see fig. II,) serves to limit the forward motion of the latter in such a manner that when acted upon by the solenoid it can not move over a greater number of contacts than those determined by the position of the handle *J*. The contact-lever *C* is in electrical connection with the switch-lever *I* through the shaft *B*.

Referring to figs. V and VI, it will be seen that the cells of the secondary battery, represented by the figures 1 2 3 4 5 6 7 8 9, and which are connected in series with each other, are consecutively connected with the binding-posts *b* *b* *b*, etc., the wire from the + pole of the first cell being connected with the binding-post *L* and *l* at the left of the apparatus and being continued from the latter to the translating devices, the current to which it is desired to regulate. The wire from the other side of the translating devices is brought back to the binding-posts *l* and *L*, the latter connecting with a segment or curved contact-plate, *M*, with which the switch-lever *I* makes connection when it is moved to the right of the instrument from a similar but smaller contact-plate, *m*, at the left, and upon which the lever *I* rests when the circuit through the instrument is open. The solenoid *F* in the present instance is connected with the binding-posts *l* and *L*, as shown in fig. I, and is therefore in multiple arc with the circuit-wires.

A series of storage batteries, shown in heavy black lines in fig. 8, are connected to the brake magnets near the wheels. The batteries are connected to a switch, so that a contact passing over them puts a successively increasing number of cells on the circuit. The cylindrical quadrant shown at the left is a solenoid which is connected in shunt with the battery circuit. Its core is prolonged and extends into a dash-pot or regulating cylinder, whose function is to regulate the motion and prevent the too rapid entrance of

the core into the solenoid when the latter is energized. A spiral spring serves to return the contact-lever together with the core and piston-rod, which are firmly secured to the contact-lever, to their normal position, so that the lever will rest upon the first contact to the left when no current is passing through the solenoid.

The operation of the device is as follows: When the circuit closing lever provided with the handle is moved from its normal (open) position on the left of the apparatus to a point on the curved plate—say to the extreme right of the apparatus—only the current from the first cell of the secondary battery will flow through the brake circuit. The solenoid, however, being now energized to a certain degree

by the derived current passing through it, now begins to attract the core and moves the contact lever to the second contact point, thus throwing two cells into the brake circuit and proportionately increasing its own force. This process continues, each additional cell thrown into the brake or working circuit also increasing the force with which the core is drawn into the solenoid; but as the dash-pot is adjusted to limit and regulate the rate of motion of its piston rod, the movement of the contact lever across the face of the contact points is rendered uniform, and additional cells are thrown into the brake circuit until the entire battery is included therein.

If, however, it is not desired to send the entire strength of the battery into the brake circuit, all that is necessary is to move the switch lever along the curved contact plate, but not so far to the right as before, it being retained in position by the segment pawl. The operation will then be the same as before, except that when the contact lever has moved forward sufficiently it will come in contact with a projection on the regulating

lever, and its further motion thereby arrested. In case the cars are operated by electric motors deriving current from a central station, the storage batteries are replaced by resistances, so that the brake coils are gradually connected to the main source of current. This arrangement is also shown in fig. 8.

From what has been said, it will be seen that the circuit closing apparatus is not only adapted to regulate and control the admission of current to the electro-magnetic brake devices just described, but is equally applicable to other forms of service, such, for instance, as incandescent lighting, in which it seems well adapted to prevent the premature wear or decay of the incandescent filaments now occasioned by the changes in temperature, due to the sudden manner in which the current is usually turned on or off. This is a great improvement, and further developments are expected.

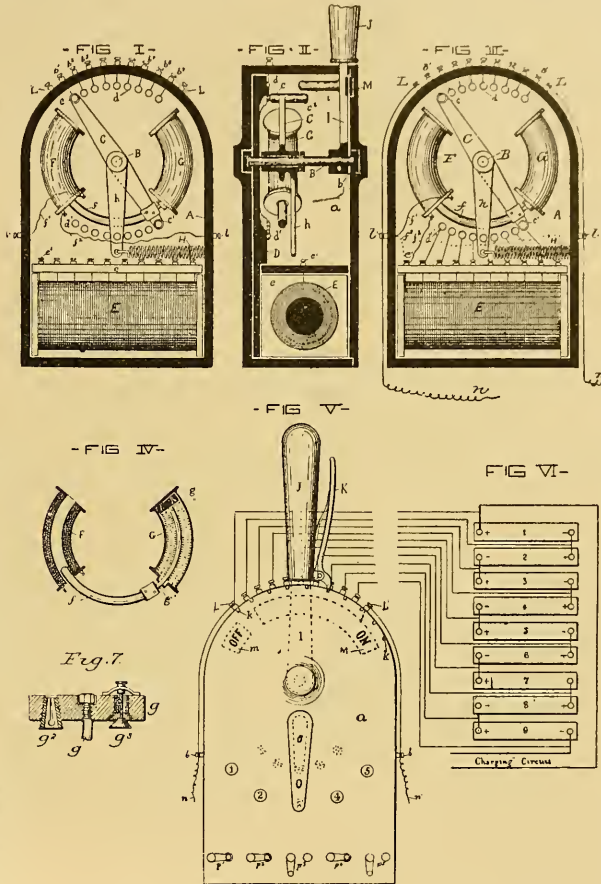

## Van Depoele, Chicago.

The progressive City of Chicago was incorporated March 4, 1837—a few days over three months before Queen Victoria was enthroned. The Village of Chicago was incorporated into a town Aug. 10, 1833—barely three years and seven months before it came out as a full-fledged city, with a total population of 4,179 (of whom 77 were colored). According to the Lake Side Directory for 1887, just issued, Chicago has now 800,000 people within the city limits; and, “notwithstanding the labor troubles, the furies in stocks, and the fickle condition of the wheat market, the town has kept on growing sideways and on top, and the chimneys of our fifteen-story-and-mansard-roof office buildings are increasing in numbers and nodding defiance to the volcanoes of the moon,” says an evening paper. But in one thing Chicago is declared to be behind the times. “Its street car facilities are far behind the age,” says the Chicago *Times* of July 2nd, in an article on the Van Depoele electric railway system, which we here reproduce as it shows how “the public” view one of our principal firms of electric railway builders:—

“The telegraphic columns of the daily papers announce from time to time the successful introduction of electric railways in smaller cities of the country. It will possibly be a surprise to most of our citizens to learn that the electric appliances for nearly all of these roads are manufactured in our own city.

“In order to present to the readers of *The Times* some authoritative data concerning the operating of electric railroads, the

VAN DEPOELE ELECTRIC MANUFACTURING COMPANY, of Chicago, was called upon for information. This company occupies the five floors of the large building on Clinton, near Randolph street, as a manufactory, and is evidently crowded to fill orders. Mr. W. A. Stiles, the secretary and treasurer of the company, in reply to a question as to the practicability of running surface and elevated cars by electricity, said:

“The running of street railways by electricity has proven a grand success, and street railways all over the country are contemplating a change from horses to electricity. The Van Depoele Electric Manufacturing company, of Chicago, has already equipped eight roads, some of which have been running over one year, and all are making money.”

“Will you name the cities in which your company have placed electric motors for this purpose?”

“The Capital City Electric Railway company, of Montgomery, Ala., thirteen miles in length; twenty cars, with 8 per cent. grades. The Dix road, Detroit, Mich., two miles; two trains of six cars each, 2 per cent. grades. The Appleton Electric railway, Appleton, Wis., four miles; five cars, 3 per cent. grades. The Windsor Electric railway, Windsor, Ont., two miles; two cars, 2 per cent. grades. Scranton Suburban railway, Scranton, Pa., four miles; five cars, 7 per cent. grades. Port Huron Electric railway company, Port Huron, Mich., four and one half miles, four cars; 3 per cent. grades. Binghamton Electric railway, Binghamton, N. Y. five miles, seven cars, 6 per cent. grades. Lima Street railway company, Lima O., four miles; three cars, 2 per cent. grades.

“The cars on these roads run from six to twenty miles per hour as desired. In addition to these roads, we are equipping under the Van Depoele system electric railways at Ansonia, Conn., St. Catharines, Ont., and Brooklyn N. Y.”

“What is the cost of running street cars by your system as compared with horses?”

“There are over one hundred thousand horses used in handling street cars in the United States—Chicago having nearly nine thousand. Five years is more than the average useful life of a horse for street car purposes. We have thoroughly demonstrated the fact that cars can be run by electricity under the Van Depoele system for one-half the cost of horses, with coal figured on the basis of \$6 per ton.”

“How would the Van Depoele system work on the proposed elevated railroad on State street, for instance, say from Van Buren street to Hyde Park?”

“It would be simply perfect. The wires carrying the motive power would be placed on the trestle-work or over the top of the cars, and could be used for all purposes, lighting, heating, and motive power. There could be no objectionable features whatever, and, as *The Times* said editorially on Thursday cities that have but a fraction of Chicago's wealth and population easily secure the investment of adequate capital in elevated roads, electric motors, and appliances for street transportation adapted to their needs. How much longer must the people of this greatest of western cities wait for the advent or awakening of enterprise enough to undertake the substitution of modern facilities for the methods of antiquity still employed in the business here?”

“There is now no question at all as to the part that electricity will take in connection with railways. The experimental stage has been passed, and nothing now remains but the practical fact of its application.”

According to the *Western Electrician* the Van Depoele electric railway system is likely to be put in practical operation in Chicago. Our contemporary says: An effort is being made to secure permission from the city council of Chicago to run an electric motor from Diversey street north, about two and one-half miles. The cable road now being laid will end at Diversey street, and the idea is to extend the road farther north, using the electric motor for power. The system of the Van Depoele Electric Manufacturing Company will probably be used.

## Battery Park.

The Rapid Transit Commission appointed by Mayor Hewitt for the purpose of laying out additional tracks and switches to connect the existing lines with the ferries in the lower part of the city of New York, have completed a second report. The manager of the Manhattan Company, which is practically the only company in a position to operate these branch lines, claimed that it would not be fair to compel them to carry passengers from one side of the city to the other for one fare, because if this was done many passengers would avail themselves of the privilege of riding down town and up town again for a single fare. The chief objection, however, the company has to the report of the Commission is the fact that the compensation to the city shall be five per cent. of the gross receipts. The company claims that its business would not be materially increased by the extension of their lines and that the traveling public would reap most of the benefits.

## Urban Railways of the World.

Such is the caption of a table of street railway statistics (including underground, elevated, surface, cable and horse railway systems) in *The Maverick National Bank Manual* (just issued), of which the following is an abstract:

	Size, Sq. mile.	Year.	Populati'n.	No. per house	Principal Means of Transit.	Year opened.
London	122	1885	4,120,000	8	Underground R'y, Buses, Hansoms	1863
Berlin	25	1885	1,345,297	50	Horse R'ys and El. Viaduct	1882
Vienna	---	1880	775,000	45	Horse R'ys	----
Paris	30	1881	2,260,000	32	Horse R'ys and Omnibuses	----
New York	25	1881	1,243,000	13½	Horse R'ys and El. R.R.'s	1872
Brooklyn	---	1880	566,663	---	Horse R'ys and El. R.R.'s	1875
Philadelphia	---	1880	847,170	---	Horse R'ys	----
Boston	27	1885	390,393	8½	Horse RR's	----
Providence	---	1885	118,070	---	Horse R'ys	----
Chicago	---	1880	503,185	---	Cable and Horse R'ys	1882
San Francisco	---	1880	233,959	---	Cable R'ys	1881



**Sand Box for Open Cars.**

The device illustrated in the accompanying drawing can certainly be recognized as one of the valuable improvements in street car appliances, for the reason that it has, after several severe and long tests, been found to answer admirably the purpose for which it was especially designed. And although quite a modern improvement, it has received, without strong or influential representation, very marked notice from many corporations and railroad companies throughout the country, who have adopted it on their roads, and express, by voluntary statements, their high satisfaction with its operation. There are now upwards of four hundred in use. The drawing shows a side sectional view, and a plan or top view.

The drawing represents a special arrangement for an

motion regulates the amount of opening of the mouth of the chute, and allows more or less sand to fall as desired. In other words, the quantity of falling sand is gauged by the foot adjusting pin *K*. The mouth of the chute is rectangular in form; the motion of opening and closing is quick; there is no liability to choking or sticking; as long as the driver keeps down the pin *K*, by the pressure from his foot, so long will the sand run out of the chute upon the track.

The peculiar form allows the use of gravel, salt, or common soil taken up from the track road.

Reference to the letters, and an examination of the drawing will make the mechanism and arrangement easily understood. In another part of this journal, the address of the manufacturing company is given, and also the names of some roads where sand boxes of this make are in use, and in successful operation.

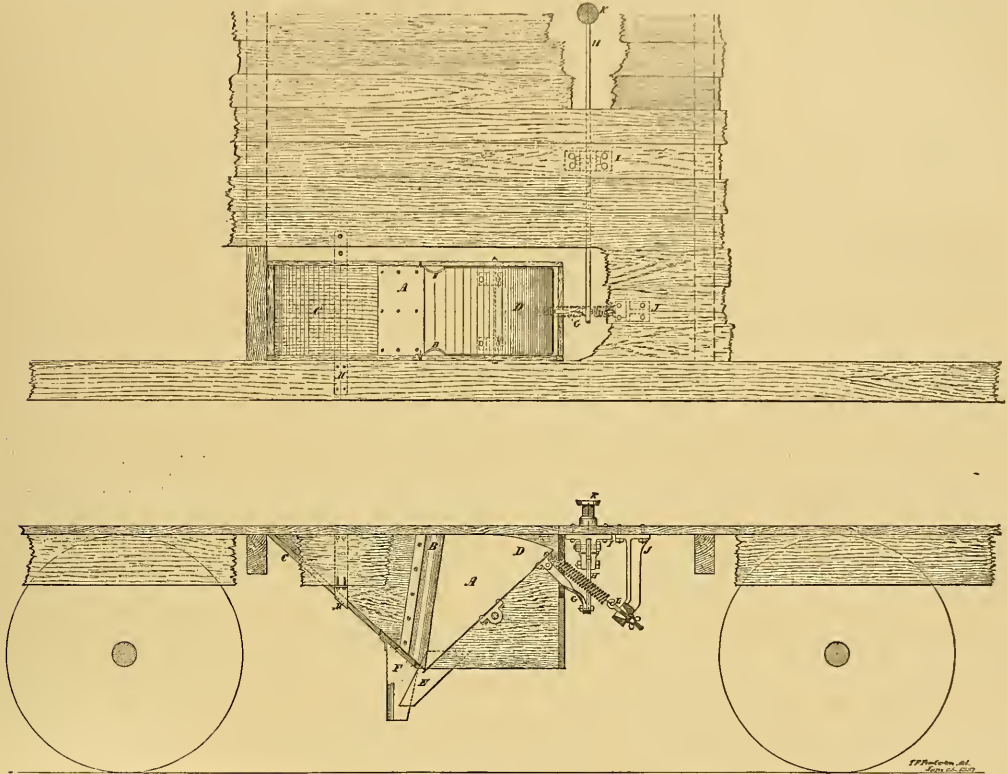

“THE RELIABLE” SAND BOX.

- A, sand box complete;
- B, concave guards;
- C fixed incline;
- D, oscillating incline;

- E, sand chute;
- F, guard for chute;
- G, vertical lever;

- H, rocker arm;
- I, hanger for fulcrum pin;
- J, bracket for spring;

- K, foot adjusting pin;
- L, book for spring;
- M, strap for supporting sand box.

open cable car, which is a deviation in the usual manner of placing the lever and its connections, but the operation is similar in all cars, the main object being to sprinkle sand, salt, gravel or common soil on the track, with a positive action and effect at an expenditure of a minimum of force. The foot adjusting pin, *K*, is placed near the driver or operator, and may be placed, as shown, in the middle of a car near the grip lever, used for throwing in and out of gear, or at the end of a car in close proximity to the brake ratchet and pawl. The traverse motion of this foot adjusting pin is slightly variable, but not varying more than fractions of an inch. By means of the screw on the foot pin, the height of *K* can be raised or lowered, and the traverse motion increased or decreased accordingly. This traverse

**Electric Cars in San Francisco.**

On an improvised railroad track of 150 feet long on Nineteenth street, between Treat avenue and Folsom street, the first trial was made, June 14, of a new car which is to be worked by electricity. And it was a grand success.

The arrangements being completed, F. N. Sheed and Professor Keith mounted the car, and Sheed turned a small handle, which set the car in motion. The car went slowly down the track and returned without any hitch. The car was then again run down the track, this time at a greater speed, and back with success. Many people “took a ride” as soon as solicited, and were highly delighted with this new mode of passenger transportation.

## Street Railways of New York.

The Board of Railroad Commissioners for the State of New York have issued their fourth annual report, viz.: that for the fiscal year ending September 30, 1886. Vol. II. contains tabulated statements of annual reports. Table A comprises 84 street (surface) railways in operation, which show \$4,242,279.11 net earnings (from operation)—to which total 74 companies contributed, while 9 made deficits, and one (Mt. Vernon and East Chester) shows \$1,859 79 gross earnings from operation, with operating expenses of the same amount.

Table G gives a comparative statement of operations for the years ending September 30, 1885 and 1886, of

## SURFACE STREET RAILROADS.

	1885.	1886.
<i>Capital Stock and Debt.</i>		
*Capital stock issued.....	\$29,450,443 99	\$29,457,323 99
*Funded debt.....	24,637,600 00	25,598,250 67
Floating debt.....	3,046,857 79	4,479 719 86
Total stock and debt.....	\$57,144,901 78	\$59,535,294 52
<i>*Cost of Road and Equipment.</i>		
	\$54,450,604 25	\$56,905,845 79
<i>Earnings from Operation.</i>		
From passenger transportation.....	\$16,481,013 74	\$17,801,464 18
From miscellaneous sources.....	81,351 96	31,670 01
Gross earnings from operation.....	\$16,562,365 70	\$17,833,134 19
Operating expenses.....	11,795,751 12	13,590,855 08
Net earnings from operation.....	\$4,766,614 58	\$4,242,279 11
<i>Income Account.</i>		
Net earnings from operation as above.....	\$4,766,614 58	\$4,242,279 11
Income from other sources.....	436,700 84	424,236 89
Gross Income from all Sources.....	\$5,203,315 42	\$4,666,516 00
<i>Deductions from Gross Income.</i>		
Interest.....	\$1,465,459 06	\$1,594,686 57
†Rentals of leased lines.....	88,216 00	306,430 28
Taxes.....	692,536 60	774,870 07
Miscellaneous.....	66,775 16	52,934 32
Total deductions from gross income.....	\$2,312,986 82	\$2,728,927 24
Net Income from all Sources.....	\$2,890,328 60	\$1,937,598 76
<i>Payments from Net Income.</i>		
Dividends.....	\$2,271,981 00	\$1,876,215 50
Miscellaneous.....	171,148 91	33,953 66
Total payments from net income.....	\$2,443,129 91	\$1,909,869 16
Surplus.....	\$447,198 69	\$27,729 60
<i>Mileage.</i>		
Miles of road built and operated.....	493.20	513.48
Miles of additional track and sidings.....	342.78	342.59
Total miles of track.....	835.98	856.07
<i>Equipment.</i>		
Horses.....	26,548	26,831
Cars, dummy, with engines.....	2	1
Cars, passenger.....	4,903	5,289
<i>Miscellaneous Statistics.</i>		
Number of passengers carried.....	327,725,714	355,253,399
<i>Per passenger carried:</i>		
Gross earnings from operation (cents).....	5.05	5.02
Operating expenses (cents).....	3.60	3 83
Net earnings from operation (cents).....	1.45	1.19
<i>Per mile of road operated:</i>		
Gross earnings from operation.....	\$33,581.43	\$34,729.95
Operating expenses.....	23,916.77	26,468.13
Net earnings from operation.....	9,664.66	8,261.82
*Broadway Surface Railroad Company, of New York City, included in 1885, but not in 1886. For comparison there should be added to 1886 the following figures of that company, as reported by it in 1885: Capital stock, \$1,000,000; funded debt, \$2,500,000; cost of road and equipment, \$3,452,000.		
†Used by lessors as follows:		
	1885.	1886.
Interest.....	\$10,162 50	\$162,971 56
Dividends.....	36,024 00	32,330 00
Not designated.....	3,029 50	111,128 72
	\$88,216 00	\$306,430 28
Total interest as per above table and note.....	\$1,514,621 56	\$1,757,658 13
Total dividends as per above table and note.....	2,308,905 00	1,906,545 50

	1885.	1886.
*Percentage of net income to capital stock.....	09.93	06.36
*Percentage of dividends declared to capital stock.....	07.83	06.16
*Percentage of gross income to cost of road and equipment.....	09.56	07.73
Percentage of operating expenses to gross earnings from operation.....	71.22	76.21
Average number of employees during year.....	12,159	13,022

There is a similar statement concerning

## ELEVATED STEAM RAILROADS.

NOTE.—The year 1886 includes the doings of the New York City system 32.39 miles, the Brooklyn Elevated 6.75 miles, and the Coney Island Elevated and its successor, the Sea View Elevated, 1 mile. Total, 40.14 miles.

The year 1885 includes only the New York City system 32.39 miles, and the Coney Island Elevated 1 mile. Total, 33.39 miles.

The Suburban Rapid Transit Railroad Company, having completed but 0.96 miles of its road, and which was not opened for business till May 17, 1886, the statistics, etc., contained in its report and shown on the respective tables are not included in this table.

	1885.	1886.
<i>Capital Stock and Debt.</i>		
Capital stock issued.....	‡\$37,084,095 00	‡\$42,528,200 00
Funded debt.....	23,477,835 00	29,095,000 00
Floating debt.....	3,715,526 20	2,656,092 32
Total stock and debt.....	\$64,277,456 20	\$74,279,292 32
<i>Cost of Road and Equipment.</i>		
	\$35,920,287 79	\$46,613,949 40
<i>Earnings from Operation.</i>		
From passenger transportation.....	\$6,796,568 58	\$7,855,466 12
From mail transportation.....	5,000 00	5,000 00
From miscellaneous sources.....	6,000 00	20 047 29
Gross earnings from operation.....	\$6,807,568 58	\$7,880,513 41
Operating expenses.....	3,627 805 92	4,238,146 67
Net Earnings from Operation.....	\$3,179 762 66	\$3,642,366 74
<i>Income Account.</i>		
Net earnings from operation, as above.....	\$3,179,762 66	\$3,642,366 74
Income from other sources.....	204,020 15	73,805 96
Gross Income from all Sources.....	\$3,383,782 81	\$3,716,172 70
<i>Deductions from Gross Income.</i>		
Interest.....	\$1,448,634 09	\$1,739,191 18
Rentals of leased lines.....	20,000 00	20,000 00
Taxes.....	350,015 76	386,417 49
Total deductions from gross income.....	\$1,818,649 85	\$2,145,608 67
Net Income from all Sources.....	\$1,565,132 96	\$1,570,564 03
<i>Payments from Net Income.</i>		
Dividends.....	‡\$1,560,000 00	‡\$1,560,000 00
Surplus.....	\$5,132 96	\$10,564 03
<i>Mileage.</i>		
Miles of main line and branches.....	33.39	40.14
Miles of additional track.....	39.42	47 32
Miles of sidings.....	10 93	13 31
Total miles of track.....	83.74	100.77
<i>Equipment.</i>		
Locomotives.....	245	303
Cars, first-class passenger.....	703	867
Cars, service.....	27	29
<i>Miscellaneous Statistics.</i>		
Miles run by trains.....	6,375,319	7,535,854
Number of passengers carried.....	103,758,571	125,453,888
<i>Per passenger carried:</i>		
Gross earnings from operation (cents).....	6 56	6 28
Operating expenses (cents).....	3 50	3 38
Net earnings from operation (cents).....	3 06	2 90

\*For comparison the figures of the Broadway Surface R. R. Co., of New York City, are included in these computations for 1886, as they were in 1885.

†This large amount is occasioned by the process of exchanging the stock of the Manhattan, Metropolitan and New York companies for the consolidated stock of the Manhattan company, under the consolidation agreement of August 1, 1884. When completed the total capital stock will be \$26,000,000.

‡Six per cent. on \$26,000,000 Manhattan Consolidated stock.



	1885.	1886.
<i>Per mile of road operated:</i>		
Gross earnings from operation.....	\$203,880 46	\$196,325 69
Operating expenses.....	108,649 47	105,584 12
Net earnings from operation.....	95,230 99	90,741 57
Cost of maintenance of way and structures.....	8,501 29	8,395 45
Cost of maintenance of equipment.....	12,543 80	11,316 11
Cost of conducting transportation.....	75,173 29	74,614 84
Cost of general expenses.....	12,426 18	11,257 72
Average number of employees during year.....	4,209	4,541
*Percentage of net income to capital stock.....	95.99	93.69
*Percentage of dividends declared to capital stock.....	95.97	93.67
Percentage of gross income to cost of road and equipment.....	99.42	97.97
Percentage of operating expenses to gross earnings from operation....	53.29	53.78

Table H contains a list of 9 elevated "steam roads" not built, of which one (Ocean Palace) was chartered as far back as 1876; but 4 of them only received their charters last year. There is also a list of 42 "steam roads—horse or cable"—not built.

Table I, which ends the tables of street railway summaries, consists of a "statement of accidents on surface street roads" during last year, from which it appears that 7 passengers and 4 employees, together with 25 "others," were killed, while 126 passengers, 11 employees, and 73 others were injured; total for the year, 36 killed and 230 injured.

The Suburban Rapid Transit Company was organized under chapter 606 of the laws of 1875, known as the Rapid Transit Act, by commissioners appointed by the mayor of the city of New York, on the 6th day of March, 1880, the certificate of such organization having been filed in the office of the Secretary of State of New York on the 19th day of October, 1880, and a duplicate thereof in the office of the clerk of the county of New York on the 28th day of October, 1880.

Since the last report the bridge across the Harlem River at One Hundred and Twenty-ninth street and Second avenue, the joint structure (a four-track viaduct) from the north end of the bridge to One Hundred and Thirty-second street, and the stem line from One Hundred and Thirty-second street to One Hundred and Forty-third street (making in all 0.96 miles) has been completed, and the same was opened to the public on the 17th day of May, 1886, and has been running regularly since.

The rights, franchises, etc., of the New York, Fordham and Bronx Railway companies were acquired under leases dated March 17, 1886, and subsequently by merger agreements dated April 9th and 27th, 1886 (certificates of which were duly filed with the Secretary of State and Register of New York County).

In New York City 115,109,591 passengers were carried on the elevated lines, and 210,039,484 on the surface lines; total 325,149,075 during the year under notice, being an increase of 30,119,823 over 1884-5. Over the Brooklyn Bridge cable railroad 24,029,267 were carried during 1885-6, from whom \$661,362 was received in fares.

THE decision of Judge Ingraham in the three cases brought to restrain the east side elevated roads from operating their road in front of certain properties, on Third and Second avenues, provides that the roads will continue to be operated but that damages must be paid to the plaintiffs or their damaged property taken off their hands, if the judgment is affirmed on appeal.

### How And When Shall It Be Done?

This is the question put by hundreds of all classes, resident in the City of Boston, relative to rapid transit and relief of the crowded thoroughfares. The travel in the city by means of hacks, herdics, and street cars has become so great that these conveyances are both a convenience and a nuisance. Add to this the narrow streets with their narrow sidewalks in the business centres, and it becomes apparent that the business of Boston, and the accommodations for travel and transit are unbalanced. Citizens, travelers and visitors all testify to the trials of temper and patience occasioned by frequent stoppages, tedious delays, slow movements, and the consumption of valuable time. Boston is notorious for its narrow, irregular streets; it is behind New York, Chicago and Philadelphia, in its general plan; it is crowded where it should have ample space and the best facilities for commercial and industrial enterprises; it is cramped, confined and irregular where wide streets are wanted for travel, for pedestrians, for exhibition of goods, for plenty of light and air, for transportation — clean, rapid and convenient.

The call is loud and strong for rapid transit, for greater facilities and the introduction of city improvements that shall ameliorate its present uncomfortable condition.

We know of no dissent in the matter. The trouble, discomfort, loss and aggravations are the common lot. The call is *vox populi* with no uncertain sound.

Allowed and granted is this evil; it is self-evident; it is felt. No time need be expended in looking for the cause, it is enough that it exists, and the question of the hour is the remedy. How and when shall it be done?

What plan will bring reform best and quickest, embodying all that is attainable, desirable and important for a city, developing rapidly in population, industry, manufactures, mercantile and commercial pursuits?

The street car travel is now very great, and is on the increase. To all the suburban localities, Cambridge, Charlestown, Malden, Lynn, Brighton, Roxbury, etc., there are both steam and horse cars. There is no lack of conveyances to any points in and around the city. The West End enterprise will add still more in this direction, more and more tracks and motors, and greater facilities.

There are neither elevated nor underground railroads. The transportation at present is entirely on the surface, and in the present outlook there is nothing which can be positively regarded as an approaching deviation from the street car system. The problem how to relieve the crowded thoroughfares is not an easy one to solve.

New York has felt the pressure and is still agitating the rapid transit subject, proving that there is nothing insuperable, although difficulties, many and great, have to be overcome, in providing for the pressing needs of a growing city.

There are some things that can not be done just at present, as the bodies and circumstances and conditions are too large, and complicated for immediate action. The streets known now as the business streets cannot be widened. The same streets are too narrow for elevated railroads. These streets cannot be touched. Any additions in tracks would make things worse instead of better. The old streets and landmarks need not be disturbed now. The only remedy is expansion. The business of the city must be expanded out into the suburbs, where there are ample land facilities for building, where wide streets and rapid transit can be introduced just as fast as circumstances will allow. This is, we opine, the remedy that Boston citizens regard as the most desirable and the most feasible.

Such a system, if carried out with honesty and intelligence and with a single eye *pro bono publico*, would be a permanent improvement, at least for a few generations to come. The health and wealth of the city would be favorably effected; and when such a system is adopted, there will be a reduction of present discomforts.

MR ANGUS SINCLAIR was elected national secretary of the Master Car Builders' Association, at their Convention in St. Paul, Minn., June 25.

\*These computations are made on the following basis:

	1885.	1886.
Manhattan Elevated (Consolidated) stock.....	\$26,000,000 00	\$26,000,000 00
*Coney Island Elevated stock.....	116,500 00	
Brooklyn Elevated stock.....		5,000,000 00
	\$26,116,500 00	\$31,000,000 00

†Reorganized in 1886 as Sea View R. R. Co., which reports no stock issued.

### The Julien Storage Cell.

As stated in previous issues of the GAZETTE, the first Julien car arrived in the United States about six months ago, and has been run experimentally, at intervals, on the Eighth Ave. RR., New York, from the station at 48th st. to Central Park and back. This experimenting car is exactly like those in use at Brussels, Belgium, where the tracks are much better than those of this country, and much difficulty has been experienced in adapting the wheels of the Julien car to our rough tracks and short curves. But those who have seen it at work, at New York and elsewhere, have become much interested therein and expect great things therefrom in the immediate future.

The accompanying illustration is a view of the cell as now made and when used with a slightly flaring glass jar. The standard accumulator of this company is that known as type B. It consists of 19 plates, 9 being positive and 10 negative, weighing 27 lbs. net, *i. e.*, without the containing box or the acid solution, which make an additional weight of from 6 to 7 lbs. The positive plates are indicated by red paint on the connecting strip. Following are the principal details of the type B accumulator:—

Floor space,  $6\frac{1}{2} \times 5\frac{3}{4}$  inches; height, 8 inches; net weight, 27 lbs.; total, 34 lbs.

Quantity of solution about  $1\frac{3}{4}$  quarts; strength of solution in degrees Baume,  $23^{\circ}$ ; strength of solution in specific gravity, 1.185.

Electromotive force, 2 volts; internal resistance, .001 to .005 ohm.

Current of charge, up to 18 amperes; current of discharge, up to 36 amperes.

Current capacity of each accumulator, 125 ampere hours.

Energy capacity of each accumulator (C.E.), 250 volt ampere-hours or watt hours.

The Julien car, with the battery, weighs about six tons; the battery itself weighing about one ton. A change has recently been made in the wheels of the car, and subsequent trials have proved very satisfactory. Recent experiments on the Fifth avenue road, New York, show that it can propel cars better than horses. One night it was run over this route with a large party of gentlemen, and the speed was raised at times to more than twelve miles an hour. The distance from the station to the City Hall was made in nineteen minutes, as against thirty-two minutes for the horse-cars. About three horse-power is the average force exerted. Next morning the car was again run over the route for Mr. Cornelius Vanderbilt and some of the officers of the Fourth avenue line. It was sent through the tunnel from Thirty-second street to the Grand Central Depot at a speed of fifteen miles an hour, the horse-cars having been put out of the way, and then it was moved in and out along all of the intricate switches and curves going in and out of the Grand Central Depot, after which it was run down town and back. At all times it seems to be under the most perfect control, starting and stopping with far greater precision and ease than could be done with horses, and running steadily at any speed, slow or fast, which was desired.

The practicability of running such a car by electricity from storage batteries carried on the car itself has been admitted for years, and it has been merely a question of cost. "The advantages are indisputable," says the New York *Evening News*, "and as compared with cable attraction the storage battery is far preferable, because if anything goes wrong with the cable the whole line is blocked, where the storage motor makes each car independent of all the others. The durability of the electric plant and cost of charging the battery have been the doubtful points. Mr. Wm. Bracken, the president of the Julien Company, said that his company would guarantee that their cars would not cost more than \$4.10 a day, running ninety miles in that time, and carrying all the passengers that could be crowded into them. The average cost of the same service with horses is \$7.50. As to durability, the battery is said to be, if not everlasting, certainly more durable than horses, and the first cost is not

so great for the electric cars as for the horse cars, and the ten horses which are required to run it all day."

One of these Julien electric cars is now running in St. Louis, and Mr. Bracken expects to have others ready for use upon the New York surface railways as soon as they can be built. The John Stephenson Company, Limited, are now finishing one for Boston, in which American gearing is used in connection with the Julien battery.

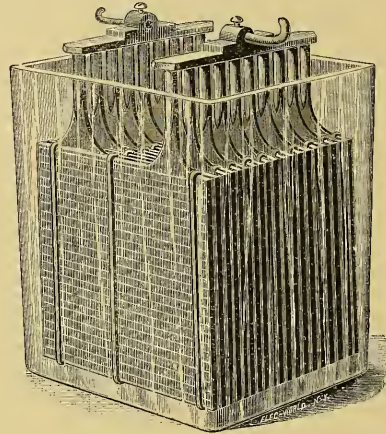

JULIEN STORAGE CELL IN GLASS JAR.

### Ammonia Gas as a Street-Car Motor.

A trial has been made of a new motor on the Carrollton & Canal Street Railway, at New Orleans, in which the propelling agent was ammonia gas, the application of which is described as follows.

"This gas, which is little more than one-half the weight of air, is powerful and expansive, and when passed through the cylinders of a steam-engine, will operate just the same as steam in moving machinery. In order to utilize the gas, it is stored in a strong iron reservoir, which is carried under the floor of a car, and is supplied to the engine just as steam is used from a boiler. In order to be able to carry enough of the gas to drive the machinery for any considerable time, the gas is forced by powerful pumps into the reservoir on the car until a pressure of from 180 to 200 lbs. to the square inch is reached, its force being indicated by a gauge much the same as a steam-gauge. Each car is supposed to carry enough gas to make a trip back and forth between Carrollton and Canal streets. The engine is not a separate matter from the car, as is the steam dummy; but each car is its own engine. There being no fire, no smoke, no steam, no heat, there is no need to have the propelling power separate from the cars that carry the passengers, but, on the contrary, the propelling appliances are compactly stored beneath the floor of the car, which in external appearance or internal accommodation, is in no way different from the ordinary street cars, save that it stands a little higher on its wheels, to make room for the machinery underneath. The engineer or driver sits on the front platform, which is no more encumbered than is the platform of a horse car, and by means of a couple of levers he reverses or forwards the engine movement at will, while a throttle valve controls the admittance of gas to the engine in much the same way as steam is managed. Right here comes in a great item of economy. The ammonia gas, after passing through the engine and doing its work, is not lost by being allowed to escape into the atmosphere, but saved simply by turning it into the air tight water tank carried under the car. The gas has such an affinity for the water that the latter will absorb 70 times its bulk, ten cubic feet of water taking up 700 cubic feet of the gas which is extracted from the water and is again utilized for driving a car."



## Construction, Equipment and Maintenance of American Street Railways.

BY AUGUSTINE W. WRIGHT.

(Continued from page 113.)

### CHICAGO WEST DIVISION RAILWAY COMPANY'S STABLES.

Figure 64\* represents ground plan, elevation, etc., of a stable built for the company named, of which Dewitt C. Creger was (and is) general superintendent, and Henry Raeder, architect.

The building may be briefly described as follows: It is 142 ft. wide by 256 ft. long, and two stories high. The footings of the foundations are of concrete throughout; they support walls above built of roughly coursed rubble masonry. The stone walls reach to a height of eight inches above the established "inside grade." All the masonry above this point is brickwork. A feature of the building is the hollow wall of the first story. The first story walls are built of two thicknesses,—an outer one of eight inches, and an inner one of four inches, the two being separated by a two-inch air space. The air space answers the double purpose of keeping the stable warm in winter and cool in summer. There are fourteen rows of stalls, separated at the front ends by a four-foot alley. The alleys are an important factor in the general scheme of ventilating the stables, as the fresh air is introduced through their floor. Underneath alley floor extends a box, made as air tight as possible, connecting with the stable by means of holes in the alley floor. At the ends these boxes or air ducts connect with the outer air, and are provided with adjustable slides for controlling the air inlets. Ventilators in the ceiling of the stable, passing through the hay loft above and ending in a cupola with adjustable slides, operated from below, aided by air ducts in the brick walls, serve to carry off all foul air. The building is most thoroughly drained and sewered. The sub-soil water is lowered by means of open tile drains surrounding the building on all sides. The sewerage system consists of a main through the centre of the building (connected with a catch-basin) and the necessary branches. The main pipe is ventilated at its upper end with a conductor spout, which also flushes the sewer at times of rain.

To this main pipe, V-shaped galvanized iron gutters, running along the rear ends of the stalls, are connected at their lowest points.

The V-shaped gutters are covered with oak plank, perforated here and there to pass the urine of the horses to the iron gutters below. All the stall floors slope toward the perforated oak plank. The floors are made impervious by laying tarred roofing felt between a floor lining and the floor proper. All waste pipes from fixtures are properly trapped. In short, the system of sewerage is carried out on strictly the same principles as is generally adopted for dwellings.

The following letters, with explanations, refer to figure No. 64: *V*, ventilators passing through the hay-loft to roof; *T*, trap doors for hoisting hay; *W T*, watering troughs; *A*, re-galvanized iron gutters; *B*, harness pins; *G*, inlet to ventilator ducts which run under floor; *C*, air space in first story wall; *C'* ventilator duct in wall.

## CHAPTER VI.

### MANAGEMENT OF STREET RAILWAYS.

The recent unsettled condition of the working classes, and consequent strikes, have not allowed the street railway managers to ignore this question, for trouble has arisen from the Atlantic to the Pacific, and from the North to the South.

As the conductors and drivers outnumber the other employees, the rules governing them are of most importance.

At the meeting of the American Street-Railway Association in St. Louis, October, 1885, Messrs. D. F. Longstreet

and H. H. Littell, men of great experience, reported as follows on "Rules Governing Conductors and Drivers":

"Every street railway enterprise is dependent for its success upon its location and management; and the management is very largely dependent upon its success upon the character and conduct of the conductors and drivers employed.

"These servants are the real representatives of the company, before the public, and just in proportion as they are civil, polite and attentive, or the reverse, will the company obtain favor or disfavor with the public. They are also the trusted servants of the company for its revenue, and upon their watchfulness, fidelity and honesty, depends in a great measure the financial success of the enterprise.

"It is, therefore, of the greatest importance that good men should be selected for these positions, and equally important that good rules and regulations should be the guide of their conduct—such rules as will commend themselves to the judgment of reasonable men, and such as will conduce to the orderly conduct of the business, and the comfort, convenience and safety of the public; not only that portion which ride in the cars, but to the large number of pedestrians and teamsters.

"The streets are for the whole public, and while the street car is given by law the right of way, it should always be taken in the least objectionable manner, consistent with a proper conduct of the business.

"To one who has examined the rules in force in different sections of this vast country, it is obvious that no complete set of rules could be drafted which would meet the local requirements in all respects, and no attempt at such a compilation will be made by your committee; but its recommendation will be confined to such general regulations as seem, from a careful survey of the subject, united with a long experience, to be applicable alike to all sections.

"The rules should be made as concise and as complete as possible; should be issued in convenient form to be carried in the pocket, and as discipline is one of the first essentials in the correct management of any body of men, they should be rigidly enforced. It should be made obligatory upon the men to carry the rules at all times when on duty.

"Ignorance of a rule should be no excuse for its violation, and willful or careless violation of their provisions should be made sufficient reason for their discharge.

"Rules are properly divided into three classes, viz :

- "Discipline and Department,
- "Comfort, Convenience and Safety of the Public, and
- "Collection of Fares.

"And we shall treat them in that order.

#### "DISCIPLINE AND DEPARTMENT.

"The conductor should have charge of the car, and any disobedience of orders or infringement of the rules on the part of his driver should be reported.

"Starting behind time, loafing, or too fast driving; driving fast in going on or off turnouts, around curves or over railroad crossings; failure to answer the bell promptly or to stop the car properly; stopping the car across intersecting streets or on crosswalks; failure to keep a sharp lookout for passengers in main and cross streets; failure to signal promptly and accurately for passengers who get on at front end of the car; carelessness in driving; permitting unauthorized persons to drive; the use of profane, boisterous, or indecent language, or the use of intoxicating liquors, are all matters which a conductor should promptly report, to relieve himself from responsibility.

"As it is important that these employees should be neatly dressed, and as taste in the matter of dress differs so radically, it will be found advantageous to prescribe some neat uniform to be worn at all times when on duty. This will add not only to their general appearance, but to their efficiency as well. A numbered badge should be worn at all times when on duty, and in a position to be plainly visible.

"They should treat each other with respect; be cautious and considerate, guarding themselves against envy, jealousy or other unfriendly feelings, refraining from all discredit-

\* Fig. 64 was published in the May GAZETTE, page 95—there designated Fig. 60.

able communications, except to those in authority, and upon such matters as it is made their duty to report. They should use no vulgar, profane, improper or ungentlemanly language, nor be guilty of any ungentlemanly conduct upon the car, to passengers or others, nor upon the company's premises. They should be civil, courteous, polite and attentive to the passengers at all times; be patient, and answer any reasonable request of passengers, and direct strangers and others, when requested, to the nearest and safest way to their places of destination. They should abstain entirely from the use of intoxicating liquors, and should not frequent any place where the same are sold. They should not accept any fee, gift, treat, or entertainment of any kind from each other or from any employee of the company. They should attend punctually at the stable to take out their cars; remain with them at all times when *en route*; conform to the running time as near as possible, and always stop and start the car by the prescribed signal. The signal in most general use is one bell to stop, and two bells to start; and upon open cars it is customary and advisable to permit the use of a whistle for signals. The driver should signal the conductor by one bell for each passenger getting on at the front end after the first collection of fares. Other signals for putting on the rear brakes, for increasing speed, or to stop suddenly, are usually provided for, and will be found useful in an emergency. Every conductor should carry a watch, keep it exact with the office time, and start his car from each terminus promptly at the advertised time.

"The proper position for a conductor, when not otherwise engaged in the performance of his duties, is upon the rear platform, standing erect and on the watch for persons desiring to take the car. He should not engage his attention in reading, in unnecessary conversation with passengers, or in any way which would interfere with a correct and prompt performance of his duty.

"The driver should stand erect, with right hand on the brake-handle, controlling his horses with a taut rein, keeping a vigilant watch for persons who may desire to take the car, not only in the main, but in side streets, and at the same time with a careful eye to avoid collisions with pedestrians or vehicles, and should always speak pleasantly to teamsters when requesting them to move. They should both be ever on the alert to advance the company's interests and always ready to assist each other in any emergency. Cars, when heavily loaded, should not be stopped on steep grades, nor upon curves, except to avoid accidents. Jumping cars from the track should not, as a rule, be allowed; on a single track it is better to change cars, or to run back to the nearest turnout.

"When necessary to eject a passenger for any cause, the aid of a police officer should be employed if possible. No more force than is absolutely necessary should at any time in such cases be used, and the names of reputable witnesses should be obtained. Suitable blanks should be furnished, to be filled out in case of accident, and upon which a full statement should be at once written and delivered promptly at the office. Articles found in the car should be promptly turned in at the office, with accompanying memorandum giving particulars.

"Safety, Comfort and Convenience to the Public.—The conductor comes in more direct contact with the public than the driver, and while many rules are applicable to him, the driver should at all times co-operate with the conductor as far as he can in carrying out the rules in their spirit and intent.

"The car should be kept clean and the lamps trimmed at all times, but it will in most instances be found desirable to provide special labor for this purpose and not make it a part of the duty of the driver and conductor. Special assistance should be given to ladies, children and elderly or crippled persons getting in or out of a car. Seats should always be provided as far as possible. During cold and stormy weather the doors should be kept closed as much as possible. The rear platform should be kept as clear of passengers as possible, and children should never be allowed to ride upon either platform. Passengers should not be allowed to stand in the doorway or upon the steps,

when it is possible to avoid it. Passengers should be requested to alight at the rear end from the side nearer the walk. When a lady leaves the car care should be taken to observe that her dress is entirely clear from the platform and steps before giving the signal. Whenever the car is stopped at the request of any passenger, care should be taken to observe that every other person upon the car is in a position of safety before giving the signal, and passengers should be cautioned, and prevented as far as possible, from leaving a car while it is in motion. Expedition in receiving and landing passengers is always desirable, but never at a sacrifice of safety to individuals.

"Disorderly or otherwise obnoxious persons, whether or not under the influence of liquor, should not be allowed to ride upon a car, and any one perceptibly under the influence of liquor should never be permitted to ride upon the front platform.

"Smoking, the carrying of dogs and the distribution of handbills and peddling in the cars, are all matters which should be regulated by rule. The names of principal streets, hotels, depots, ferry landings, public squares and places of amusement, should be distinctly announced as the car reaches them. Provision baskets, or soiled or greasy bundles, should not be allowed inside a car, and not outside to the inconvenience of passengers or injury to car. Nothing should ever be hung upon the rear brake handle. The car should always be stopped a reasonable distance before crossing a steam railroad track at grade, and the conductor, in the absence of a flagman, should go forward and give the signal to the driver to advance. If inside the car, the signal to go ahead should not be given without inquiring if all is right and receiving an affirmative answer. Passengers should be notified of any approaching danger, as an obstruction in the street.

"The liability to accidents on open cars is much greater than on box cars, because of so many places of entrance and exit, and consequently the very highest degree of care is necessary when running them.

#### COLLECTION OF FARES.

"There are few if any companies to-day which do not provide some sort of registering device to be used by the persons responsible for the collection of fares, and the rules governing the collection will depend upon the device used.

"As a rule the conductor should commence to collect fares at the front end and work to the rear. After fares have once been collected the driver should signal by one bell for every person getting upon the front platform, and all additional fares should be collected promptly, as soon as passengers reach the place in the car to which they intend to go.

"Each fare should be registered at the exact place where it is taken, in the presence of the passenger paying it, and before another is collected. When fare-boxes are used the driver is also the conductor, and should not be permitted to handle the fares, but should see that every passenger's fare is deposited in the box.

"Having completed a set of rules to his satisfaction, no railroad manager should stop then; rules, no matter how good, will not enforce themselves, but the better the class of men employed, the easier it will be to enforce good rules.

"Drivers and conductors should be not only faithful but intelligent, for they are very often called upon to use discretion in matters which it is impossible to cover by the rules.

"As far as possible, these employees should be selected from among the residents of the city or town in which the road is located, and such as are favorably known and endorsed by reputable citizens of the town. When first employed they should not be less than 21 or more than 40 years of age, energetic and of good habits. The pay should be sufficient to attract and hold such men, and their hours of labor should be fixed within the bounds of reason."

(To be Continued.)

THE Rasmussen Cable Company are negotiating for the conversion of several horse railways into their cable system.



### Double Deck Cars.

While top seats to cars, omnibuses, and coaches are in general use in Europe and South America, and other parts of the world, they are scarcely known in the United States. On the one hand it has been claimed that the direful effects of the sun in the summer, and the prevailing cold in the winter, would preclude the use of these seats in this climate. On the other hand it has been urged that they would be patronized, if placed upon our lines, during the greater part of the year, and thus seats could be furnished for many who are now compelled to stand.

In most parts of Europe the laws regulate the number of passengers. Penalties are strictly enforced against the companies in case a passenger is allowed to ride without being seated. There are very few exceptions to this rule. For this reason alone it is quite important that the street railway and omnibus lines avail themselves of the roofs of their vehicles to afford accommodation for seating passengers. This matter does not concern American street railways, for we load our cars without restriction. Hence there is no necessity to resort to top seats here to carry the passengers. Then it should be remembered that the climate of most of the European cities where top seat cars are in use is mild; and they may be used with comfort to passengers nearly the whole of the year. In England, Scotland, Ireland, France, Germany, Austria, and Belgium the top seats are patronized without regard to the weather, although there is no covering to protect the passengers from sun or rain. This fact may be accounted for by the reason that the top seats generally are only half the fare of inside seats.

Different cities of the United States have had a varied experience in the use of double deck cars. In the city of New York, the John Stephenson Company made omnibuses and cars with top seats in 1833, and thereafter for several years; but they passed out of use in about twenty years. The experience of street railway men seems to be that such vehicles are heavy and sluggish—that they are not convenient of access to the top seats—that they could not be utilized for a considerable portion of the year, because of the extreme heat and cold; and that they eventually would become unprofitable. About eight years ago the Sixth Avenue line put in service two of the finest top seat cars ever manufactured; but the people avoided them, and after two years' trial they were laid up; and after five years' storage were sold for five hundred dollars each—although they cost fourteen hundred dollars apiece—and went to South America.

The first cars run by the Cleveland Railroad Company were constructed with top seats; but they carried so few passengers that the upper deck was scarcely used at all. This road is now equipped with "flop seat open cars" for summer use, which answer every purpose of double deckers, with none of the annoyance of extra climbing. The numerous shade trees in that city would also interfere with top riders.

Some twenty years ago there were some double deck cars in operation on one of the lines of the city of Cincinnati. The patrons of this line liked them; but the cars were discontinued on account of the heavy grades. The people living along this line, however, objected to these cars because the use of them deprived the occupants of the privacy of the second story of their dwellings, which they had hitherto enjoyed.

The objection to the use of these cars, which has been made on account of the weather, is not sound, it would seem. They have been successfully employed as far north as Montreal for four months of the year. They could advantageously be used in the northern states for about eight months of the year; and the whole year around in the southern states. In the City of New York there is a new stage with a top seat, which is placed at the front, directly behind and above the driver's seat, and has a capacity for four persons. For eight months of the year this seat is used, and one may see ladies climbing up over the wheel of the stage to reach the seat on top, even at the risk of falling. That cars or omnibuses constructed in this manner would be much heavier and more cumbersome than those now in

use is most true; and if the law did not intervene to prevent crowding, possibly they would never be used. But this objection could be obviated by a mere police regulation.

In nearly every part of the world the top seat of the vehicle, from the aristocratic four-in-hand to the democratic tramway car, is considered the most desirable, not only on account of the temporary enjoyment it affords, but for its substantial benefits to the public health. Probably this agreeable and beneficial custom may yet be honored in the United States.

### The Bentley-Knight Electric Motor.

Electric railways, like everything new in human affairs, depend for their success or failure upon the faith of street railway managers and the public. According to their faith will it be unto them. That they can not succeed against demonstrative prejudice is shown forcibly by the interesting statement made some time since by the secretary of the well-known company named above, and which we reproduce here as a word in season to help those who are halting between two opinions—wishing to adopt one of the electric railway systems, and yet fearing it may not succeed.

In reply to certain comments by *The National Car and Locomotive Builder* on the report made by the committee of the American Street Railway Association on the subject of electricity as a motive power, Mr. Robert W. Blackwell, Secretary of the Bentley-Knight Company, says:

The Bentley-Knight Electric Railway Company is only too desirous of being "taken up" in its offer to equip fully any first-class street railway, under contract specifying that no payment shall be made until every requirement therein is specifically fulfilled; that it will furnish on demand "detailed and reliable estimates," and that it requested the committee to allow such formal estimates to be laid before the Association for consideration, with the sole result of having its letter to the committee published in the report, unbacked by any business-like statements whatsoever.

Of the gentlemen who criticised our system, and stated our inability to perform the required work when offered, we can only say that one of them deliberately broke a formal contract with us from wholly personal reasons; another offered us the right to use a part of his line, wholly for our own amusement, on condition that we laid the line at our own expense, under bonds, and removed it entirely thirty days after its completion; while a third commentator, who stated that we refused an offer made us by him, omitted to state that the section of line he offered comprised the most phenomenal grades in the hilliest city of all New England, and that his company refused to make any stipulation whatsoever as to payment upon completion of the work, even when we offered to build the whole road and run it for three months subject to the company's full and entire approval.

Electricity is ready to do the work, and it can to-day demonstrate its superiority over any other known power for the service in question. When the street railway men of the country give it a fair chance, treat the offers made as business propositions, and do not condemn it unseen, simply on the ground of novelty, electric tramways will become an established fact—certainly not before. The rustic in *Punch*, whose first idea on meeting a stranger was to fling half a brick at him, fairly exemplified in his demeanor the amount of courteous consideration extended, even in this progressive age, to a new idea.

The length of time consumed in journeys by even the best kind of carriages of past times, is now matter for surprise. The stage-coach which went between London and Oxford in the reign of Charles II., required two days, though the space is only fifty-eight miles. That to Exeter (163½ miles) required four days. In 1703, when Prince George of Denmark went from Windsor to Petworth to meet Charles III. of Spain, the distance being about forty miles, he required fourteen hours for the journey, the last nine miles taking six. The person who records this fact says, that the long time was the more surprising, as, *except when overturned*, or when stuck fast in the mire, his royal highness made no stop during the journey.

# The Street Railway Gazette.

	Annual Subscription (Including Postage).	Per Copy.
United States, Canada.....	\$2.00.	20c.
Great Britain, Ireland, India, Australia.....	10s.	11d.
Germany.....	9mk. 75 pf.	89pf.
France, Belgium, Switzerland.....	11fr. 95c.	Fr 1.10.
Spain.....	11rs. 95c.	Ps 1.10.
Austria, Holland.....	5fl. 74c.	53c.
Italy.....	12 lire.	1½ lira.
Venezuela.....	12 bolivars.	1½ bol.
Mexico.....	\$2.96.	30c.
Ann. Subs. in Argentine Republic, 2½ peso; Brazil, 4 milreis; Turkey, 54 piasters		

Registered Cable Address=TRAM, CHICAGO.

PUBLISHERS:

THE WRIGHT-MONROE COMPANY.

Augustine W. Wright, - - - - - President.  
 E. V. Cavell, - - - - - Secretary.  
 S. L. K. Monroe, - - - - - Treasurer.

GENERAL OFFICES:

CHICAGO, - - - - - NEW YORK, - - - - - BOSTON.

CHICAGO:

9 LAKESIDE BUILDING.

P. G. Monroe, - - - - - General Manager.  
 William Hughes, - - - - - Editor.  
 Edward J. Lawless, - - - - - Associate Editor.

NEW YORK:

181 BROADWAY.

Henry C. Lockwood, - - - - - Resident Editor and Manager.

BOSTON:

19 TREMONT ROW.

T. P. Pemberton, - - - - - Resident Editor and Manager.

EUROPEAN OFFICE:

LONDON: W. S. G. Baker, Jr., (care Brown, Shipley & Co.), Res. Mgr.

BRANCH OFFICES:

ATLANTA, Ga.: Chamber of Commerce Bldg., Wm. Minnigerode, Mgr.  
 SAN FRANCISCO, Cal.; 1222 Bush St.,—G. W. Fairchild, Manager.

CANADIAN AGENCY:

TORONTO: 53 Magill Street,—Thomas Henry, Manager.

## Street Railway Directory of the World.

We have much pleasure in announcing that our Street Railway Directory of the World is so far advanced that we hope to be able to issue it as a supplement to our next issue. We return thanks to those who have readily furnished the returns necessary for the compilation of this Directory, which is the first one of its kind published with any degree of completeness and classification.

"WHENEVER 'the storage battery system' is proven a success, we are ready to hitch on," is the declaration of the Dayton (O.) Street R. R. Co. in response to the question, "What improvements do you intend to make?" It seems they have made up their minds to adopt the storage battery system as soon as they may be convinced of its success. What would be their alternative is not hinted, or may not have been thought of. It is only one thing they are resolved upon, viz: to remain in *statu quo* "until the storage battery system is proven a success or a failure." If it turns out a failure, what then?

"INDUSTRIES," it will be remembered, some time ago offered a prize of one hundred guineas for the best designs for an electric motor. The committee of jurors selected two designs as being the best, namely, those marked "Agir" and "Ironclad." It is now intended to have two motors constructed in accordance with these designs, so that the machines may be put into a practical competitive test." It will then be seen which is the best in practice. In the meantime the two competitors remain unknown, and the final result of this competition is awaited with great interest, on both sides of the Atlantic.

A BONUS is offered by L. C. Berkeley and others for the construction of a street railway at Danville, Va., and whoever may risk the venture can have the privilege of exemption from taxation. This is quite a contrast to the burdening policy of New York City, etc.

CANADA is about to make a new connection with its glorious sister, the United States: the Niagara Falls, Wesley Park and Clifton Tramway Co., of Niagara Falls, Ontario, contemplate the construction of a branch of their street railway system across the Suspension Bridge over Niagara River—"connecting Canada and the United States" by their road.

"THY country shall be my country," the Port Huron Electric Railway Co. seem to say to the immense reservoir of natural gas that underlies the city of Port Huron and surrounding country. The electric railway now extends nearly four miles; the electric force which propels the cars most elegantly, and at any desired speed, is generated by machinery propelled by steam furnished by boilers heated by liquid fuel direct from the bowels of the earth, viz., natural gas. The travel on this electric railway is very large: thousands are wafted thereby daily to the beaches on Lake Huron for pleasure and recreation.

MUSTANGS may hereafter be tamed and broken in with a new arrangement, invented by general manager J. H. Small, of the Pavonia Ferry St. R.R. Co., Jersey City, N. J., which consists of a large circular structure, about 100 feet in diameter. The top of it is a circular railroad, and pendant from the rail there are a number of swing sticks, with a ring in the bottom, and a wheel which runs on a centre-bearing rail overhead. The small, hardy and easily sustained wild horses of the prairies are hitched to an apparatus at the end of the rings, and are driven around a circular track until they learn to go steadily on all fours.

MACON, Ga., has street car facilities equal to any city, if not superior to any other in the South. It has probably more cars to the 1000 population than any other southern city. "Macon is near the centre of Georgia. Has eight steam railroads, and more now building into it. It is growing rapidly, and is one of the loveliest cities in America. It has more large and handsome parks than any other city south of the Ohio River. It is the educational centre of the Gulf States, growing in manufactures and in everyway." And street car extension is steadily increasing there, which, perhaps, is the surest sign of Macon's prosperity.

HORSES are likely to find their occupation gone in the Hidden Treasure tunnel at Sunny South, California. The Auburn (Cal.) *Republican* is quoted in the *Mining and Scientific Press* as saying: A cable for hauling cars into the Hidden Treasure tunnel at Sunny South, Placer County, will soon be put in if found practicable. The expense will be nearly \$10,000, but the cars are now hauled in by horses and the cables will make quicker time. There will also be a saving of the air now consumed by the horses, which is deemed an important consideration.

BOSTON may take a hint from our account in this number of what is being done in London in the way of providing means of rapid transit from the heart of the city to the country. What may very properly be called a subterranean railway is being constructed from King William St. underneath all building foundations, pipes, sewers, etc., and even beneath the deep bed of Father Thames, to be operated by the Hallidie cable system. The very reading of the description thereof has a healthfully cooling effect. There are strong indications, from various authorities, in this month's GAZETTE that the "Hub" is in great need of increased rapid transit facilities; and it is also evident that the streets can not afford any further accommodation—unless it be for an elevated railway. But why not "expand" downwards? And London shows them the way to construct a railway underground without the slightest interference with things as they exist. Its practicability being already demonstrated.



## U. S. Mail Street Cars.

Our go-ahead friend, the Hon. Geo. B. Kerper, president of the Mt. Adams and Eden Park Incline Railway, Cincinnati, Ohio, has made arrangements with the United States postal authorities to have letter-boxes placed on his street cars for the convenience of passengers. This will confer the privilege and honor of precedence to the cars of the Mt. Adams lines, and all other cars and vehicles of every description will have to stand aside and clear the course of the U. S. mail street cars.

## Van Depoele Electric Railways.

"The horses must go," according to the conclusion arrived at by the Van Depoele Electric Manufacturing Co., of Chicago, and many others are of a similar opinion; in fact, we may well say that there is a very general desire among our principal street railway managers for some power other than horses—some look for relief to the cable system, while others are inclined to put their faith in electricity. In a circular recently issued by the Chicago electric railway electricians, it is said: "There are over 100,000 horses used in hauling street cars in the United States; Chicago has 8,625, Cincinnati 2,179, St. Louis 2,815. Five years is more than the average useful life of a horse for street car purposes. "The wonderful success of the Van Depoele system of propelling street cars by electricity has convinced street car men that the horses must go, more especially since it has been thoroughly demonstrated that cars can be run by electricity under the Van Depoele system for one half the cost of running by horses."

A list of the street railways operated by the Van Depoele electric system is given in our quotation (in another part of this issue) of the Chicago *Times* interview with Mr. W. A. Stiles, the secretary and treasurer of the Van Depoele Co.

## An Innovation in Horse Railways.

Sleeping cars have been placed on a surface railway with horses for motive power, in the heart of the Argentine Republic! To those who have had experience with only the ordinary street railway lines this will appear strange, if not ludicrous. But taking into account the fact that the horse railway in question is two hundred miles long—probably the longest of its kind in the world—the utility of such an adjunct as a Pullman car becomes at once apparent. And the fact that horses provide the motive power is due to the great scarcity of coal and the cheapness and plentifulness of horseflesh. There are four magnificent sleeping cars thoroughly equipped in every respect. They were manufactured in the United States, it is stated. Several hundreds more are to follow. The interior of the car is finished in solid mahogany, handsomely inlaid with marquetry work. The ceilings are of bird's-eye maple and the trimmings elaborately chased in nickel-platings. Attached to the car proper is a neat lavatory furnished with all the essentials of a complete modern toilette.

The street cars run in groups, one never being seen alone nor two together, but always three or four in a row less than half a block apart. Instead of starting from the terminus one every five or ten minutes, several are started at once every half hour. To run each car it requires two conductors besides the driver, and also in many places two or three soldiers armed cap-a-pie. The first conductor approaches a passenger, sells him a ticket and pockets the money, and soon the second conductor comes along and takes up the bit of printed pasteboard; meanwhile the brass-buttoned guardians of the peace stand glowering upon you, with suspicious eyes and loaded carbines. In some respects the double-conductor system is better than the "punch-in-the-presence-of-the-passengers" mode of the United States; but though the soldiers are provided to insure the safety of passengers from robbers and revolutionists, a timid person is more worried by their presence than by the possible dangers they are supposed to avert, says a Sacramento correspondent.

## Our London Letter.

The Belfast Street Tramways Company, has a good method of cleaning its grooved rails (which it uses in common with all the tramways in Great Britain). This consists of a tank car, constructed to hold about three and a half tons of water, with a feed pipe leading down to the track between the wheels on either side of the car; by this means a jet of water is used to flood all dust, dirt, etc., out of the grooves of the rails.

In the city of Glasgow a similar car is used, but with the addition of a sprinkler behind.

This Belfast company is doing quite well, having eleven miles of open track, with forty-eight cars and three hundred and sixty-five horses, and pays a dividend of six and a half per cent., which over here is considered very good. It is the second largest company in Ireland, the first being the

Dublin United Tramways Company of Dublin. This company is on a better financial condition than the Belfast company, though its dividend for 1885 was not so large. Its total expenses per mile run was nineteen and a half cents against the Belfast company's sixteen and a half cents, while its total receipts per mile run were twenty-six cents, against the other company's twenty-two cents. This company has one hundred and forty odd cars and one thousand odd horses, with an open mileage of thirty two miles. They have built for the Manchester Exhibition and are now exhibiting a car which does them great credit, and is equal to anything I have seen over here for finish. It seems to be becoming more and more prevalent in this country for tramway companies to build their own cars, and I must say that the work they turn out compares favorably with that of the regular tram car builders.

The Edinburgh Street Tramways Company, of which Robt. Hutchison, Esq., the president of the Tramways Institute of Great Britain and Ireland, is the chairman, is doing very well indeed, and is a progressive road. They use a patent brake, the invention of Mr. Booth, their manager, which consists of a wooden block, which is rammed down in front of the fore wheels on the track, and, I understand, serves its purpose very well. They say it is needed on account of the steepness of their gradients, and the sharp curves thereon. This company built a car and exhibited it at the "Exhibition" of 1886 at Edinburgh, for which they received a first prize.

They are now laying a cable system in Edinburgh, modelled after the present system at Highgate, London, but much improved. It is being laid under the auspices of the Patent Cable Tramways Company, of London. The conduit is bell-shaped and entirely cement, with the pulleys fifty feet apart. They have adjustable bearings, intended to correct any uneven wear. The company are very sanguine of successful operation, though the only existing cable system now in use in Great Britain, viz.: The Steep Grade Tramways and Works Co. just referred to, is now in liquidation, and is being worked by the Patent Cable Tramways Co. for the debenture holders. They have twelve thirty-foot bogie truck cars (the first of their equipment) almost finished. They were built by the Metropolitan Carriage & Wagon Works, of Birmingham.

The Dundee & District Tramway Co., under the able management of Dan'l Duff, Esq., has, by adopting steam as a motive power, reduced its expenses and put the road into a somewhat more healthy financial condition. In Birmingham and Leeds steam power has been adopted as a motor with great success, more especially where the tramways run out through the suburbs.

They are building a cable system similar to the one in Edinburgh in Birmingham.

The Liverpool United Tramways and Omnibus Co., who lease their lines, built upon the "Lyer" system, from the city, have unquestionably the finest track in the world. The "Lyer" system is certainly as good as could possibly be built; and for comfort and steadiness in riding is unsurpassed anywhere. This company leased sixty-one and a half (61½) miles from the city. Their present lease does not expire until 1904. They have quite large shops, of

which Mr. Winchester is the manager, where they build their own cars and busses, and turn out very creditable work. The company was at one time nearly bankrupt, but was reorganized under the present Secretary, John O'Neil, Esq., whose successful management enables them now to pay 5% dividends, with an added bonus, in the last half of 1886, of 2½%. This profit may appear ridiculously small to American eyes, but is decidedly good for England.

The North Metropolitan Tramways Company, of London, is the first (in the sense of "first in war, in peace, etc.") tramway in England. It has three hundred and seventeen (317) cars, and an open mileage of thirty-nine and one quarter miles. It pays 9¼% dividends, and happy is the man who possesses its stock. It is run upon very conservative principles, which, though they may be kept by them a little behind the times, still keeps the road very safe financially in that they lose nothing by unsuccessful experiments.

Nowhere in England is the conservative principles of the nation better shown than in a majority of the tramway companies—"What did for my father is certainly good enough for me," would serve most admirably for their motto. They decidedly want an infusion of American dash and enterprise; and I think if a company was formed to breed and raise tramway managers, crossing the conservative business principles of the present English incumbents of such positions, with the energetic, go-ahead enterprise of the Americans, that the product would be an almost perfect manager, provided always that the sharp strain of blood could be kept out of the breed. Take the idea for what its worth; *verb. sap.*, you know.

In my next letter I will give information about the International Tramways Union. W. S. G. B.

### Death of Jackson Bailey.

JACKSON BAILEY, editor and one of the founders of the *American Machinist*, died at his home in Brooklyn, N. Y., Thursday, July 7, in the forty-first year of his age, of consumption of the bowels.

Born at Schenectady, N. Y., May 12, 1847, Mr. Bailey enlisted as a private in the One Hundred and Thirty-fourth Regiment of New York Infantry at the age of fifteen, and served three years to the close of the war. He was at Missionary Ridge and in several other battles, and served in Sherman's army during the march to the sea.

Mustered out of service at eighteen years of age, he entered the State Normal School at Albany, N. Y., from which he graduated in due course and afterward was engaged in teaching. Later on he connected himself with a New York publishing firm, which position he relinquished to become New York representative of the *American Manufacturer and Iron World*, of Pittsburgh.

In November, 1877, the *American Machinist* was established, Mr. Bailey retaining his connection with it up to the time of his death. He leaves a widow.

At the time of his death Mr. Bailey was First Vice-President of the New York Press Club, a Mason, and a member of a number of engineering societies. The funeral took place from his residence Sunday, July 10; interment at Cypress Hills Cemetery in Brooklyn.

In the death of Mr. Bailey the press of America loses one of its most valued members, and THE STREET RAILWAY GAZETTE a dear friend; but his useful life and proud record is our consolation in this hour of bereavement.

### City of London and Southwark Subway Company.

Inspired by the adage that "facilities create traffic," this company is constructing a street railway under the famous River Thames—from King William Street in the city, in the direction of London Bridge to that spot in Southwark called the Elephant and Castle, and opposite to which is the Metropolitan Tabernacle, where Mr. Spurgeon preaches, and some distance beyond—to the extent of 6½ miles altogether. The following observations thereon are culled from *Engineering*:

The fact that the new undertaking is called a subway, a term not hitherto used except for short underground passages between adjacent railway stations, suggests that it differs from all existing means of transport so distinctly that it can not be classed with any. It can not fairly be called a tramway, although it is designed to use the longitudinal form of car, for it lies entirely below the surface, and has certain definite stopping places or stations. Neither can it be exactly defined as a railway, for the haulage will not be by locomotives, and the maximum speed will be below that we expect from a train, though the average speed will be about the same as on the underground lines. The line is also laid with a toleration for existing structures which the railway engineer would never dream of, and instead of imitating the march of an Oriental monarch by having the hills and valleys altered to afford a straight path, it quietly eludes all obstacles, and confines itself to virgin ground beneath the public highway with a pertinacity which must be trying to all the impecunious "frontagers" on the route. This indeed is the salient feature of the new system introduced by the subway, and may be summed up in the phrase "no compensation." In the whole distance there is only one small spot where private property is trespassed upon, and even there no purchase of freehold has been made, a right of easement being obtained instead. The rest of the distance lies under parish roads, and the project has obtained Parliamentary powers, as a work of public benefit. This, of itself, is no guaranty of cheapness; as the construction of the railway under Cannon Street shows, the cost of underpinning the houses and of diverting all the pipes and sewers may be a very formidable item. But the subway takes a course below all foundations, pipes, and sewers, and is being laid by a method which is an absolute guarantee against settlement, the tube adapting itself with the most accurate exactitude to the cylindrical channel which its steel-toothed mouth bores out before it, and not disturbing the surrounding soil in the slightest degree. It might be driven under a terrace of speculative villas without producing a single crack in the flimsy walls. The economy of construction obtained by keeping the subway low, entails the disadvantage of having the stations at a considerable depth below the street, and were the passengers obliged to climb the ascent, which varies from 40 ft. to 60 ft., many would think the ride dearly purchased by the fatigue at the end. The experience of the Mersey Tunnel (opened since the Subway Act of 1884 was passed), however, shows that passengers may be lifted by hydraulic hoist from deep stations without any difficulty, and that the public learns to use this means of transit as a matter of course, and without any feeling of nervousness. The general introduction of the direct-acting elevator has robbed lifts of their terrors, and now ladies enter them readily, feeling in the knowledge that they are supported by a 10-in. steel column, a security which they never could experience when dangling from a chain, no matter what its dimensions. The hydraulic hoist is the key of the subway system, and on the care with which this part of the work is carried out will depend much of the success of the undertaking. If passengers find that they can be carried up to the street without loss of time, and that the machinery works without hitch or accident, they will care very little as to the number of feet they are raised. It is proposed to place two lifts at each station, each capable of carrying fifty people—half a train load—and that each shall make its journey in fifteen seconds. If this arrangement be followed the exit would be gained much more quickly than it is now

THE new Westinghouse building for the joint offices of the various Westinghouse Companies in Pittsburgh is being rapidly pushed. It will be fire-proof throughout. It has a floor plan 80x110 and is 200 feet in height, with three high-speed-passenger elevators; and will be lit throughout with incandescent light, and warmed by indirect steam radiation with natural gas as the fuel. This magnificent building will be occupied exclusively by the offices of the various Westinghouse Companies.



from the stations of the District Railway, where the progress of the crowd is regulated by the speed of the slowest units, and at the rate at which the tickets can be collected. At Liverpool the hoists at the James Street Station have a lift of 76.6 ft., and at the Hamilton Street Station of 87.7 ft., and carry each 100 passengers, so that the proposed lifts on the subway do not exceed the bounds of experience. The pressure water will be obtained from pipes laid within the subway from a pumping station near the Elephant and Castle, all the stations being supplied from this source. The up and down lines of the subway are absolutely distinct, each being carried in an iron tunnel. These two tunnels do not necessarily run side by side; they commence together at the terminal station in King William Street, but the down line falls more rapidly than the other, and before Swan Lane is reached, it has taken up a position exactly below the upper tunnel, and removed from it by some 5 ft. This arrangement is adopted because Swan Lane is too narrow to allow the two tunnels to run down it side by side without encroaching on the adjacent private property. At the bottom of Swan Lane the tunnels enter the river bed, the upper one 15 ft. below the surface, and then the lower deviates a little to the right until the two are side by side. At the opposite bank of the river there is no convenient road for the subway to follow, and it therefore crosses under Hibernia Wharf into Borough High Street, after which the tunnels maintain their relative positions. In plan they are side by side with about 5 ft. intervening between them, but in section one is at a lower level than the other, in order to reduce the standing expenses at the station, by rendering it possible to work them entirely from one side. The passengers from the lower platform will pass under the other, and will ascend by a short ramp to the waiting-room from which the lifts and staircases start. Thus the entire premises will be confined to one side of the street.

Each tunnel is 10 ft. in diameter inside, and is formed of rings of segments bolted together by internal flanges. Each ring is 1 ft. 7 in. long, and is composed of six equal segments, and a short key segment with parallel ends. The flanges are  $3\frac{1}{2}$  in. deep by  $1\frac{1}{4}$  in. thick, and are bolted together by  $\frac{3}{4}$  in. bolts. The circumferential joints are made by tarred rope and cement, and the longitudinal joints by pine strips. The method of erection is almost as simple as the tunnel itself. At the head of the subway, supposing a short length of tunnel to be already in place in the clay which underlies the River Thames, there is a steel shield consisting of a cylinder 6 ft. long, and sufficient diameter to slide easily over the portion of the subway already bolted together. The forward end of this cylinder has a cutting edge, while about midway of its length there is a bulkhead having a door in it. Through this aperture the workmen remove a part of the clay in front, cutting out a small chamber considerably less in diameter than the shield. When this has been done the shield is forced forward by six hydraulic rams fed by two hand pumps. The hydraulic cylinders are bolted to the shield, while the ram heads abut against the last ring of the completed tunnel. The cutting edge clears out an exact circle in the clay, forcing the material into the space prepared for its reception, from which it is dug out and loaded through the door into skeps for removal. As the shield moves forward it leaves at its rear an annular space, of about an inch, between the iron and the surrounding clay, and this is immediately filled with grouting to prevent any subsidence either of the tunnel or of the ground. The method by which this is accomplished is very ingenious, and is due to Mr. J. H. Greathead, the engineer-in-chief of the undertaking. The grouting, made of blue lias lime and water, is mixed in a wrought-iron vessel provided with paddles which can be worked from the outside. The vessel is closed, and compressed air, at a pressure of 30 lb. to 40 lb. per square inch, is admitted to it, while the paddles are kept at work. By means of a hose pipe ending in a nozzle, the grouting is forced through holes left in the iron lining into the space between it and the clay, until the entire cavity is filled with a shell of cement which fits it exactly, and forms an impermeable coat round the subway, protecting it from moisture and oxidation. After

the shield has been moved forward a ring of segments is bolted in, the rate of progress being about 10 ft. in twenty-four hours.

The plan of operations shows the same economy and respect for public convenience which marks the entire scheme. No street surface has been taken to form a contractor's yard, but in place of this a stage has, by the permission of the Thames Conservancy, been erected in the river behind the Old Swan Pier, and from this a shaft has been sunk through the river bed to the requisite depth. On the stage there is erected a crane which lifts the skeps of clay, and delivers them on to a small tramway, along which they run to deliver their contents into barges; there is also a fan and an air compressor driven by a small engine, and a wooden office, this constituting the entire present overhead plant of this great undertaking. The shaft is 13 ft. in diameter, and is made of cast-iron rings, each cast in one piece. The thickness of metal is  $1\frac{1}{2}$  in., except at the bottom where it is thickened on the inside, contrary to usual practice, to form a cutting edge. This shaft was erected in the usual manner by removing the material from inside it with a grab, and descends nearly to the crown of the upper tunnel. From this point it is carried down in brickwork, mouthings for the two subways being made in it of the same material. There is no water to be dealt with, the tunnels being absolutely tight, and the work of extension goes most smoothly. Indeed it is impossible to realise, except by personal inspection, what a simple matter tunnelling in clay has become by the method employed by Mr. Greathead. This plan, however, is by no means restricted to clay, but can be modified to suit mud, sand, gravel, and rock.

When the ground is so soft that it can be washed away, the method of removal by pick and spade is abandoned, and in place of this a constant circulation of water is maintained at the outer face of the shield by means of a pump. In the first instance, before the distance from the shaft becomes too great, a very simple plant will suffice. Two pipes, one bent over to dip into the river, are led down the shaft and along the tunnel to the shield, through which they pass, the one near the top and the other near the bottom. Water is drawn by a circulating pump from the river and forced out through the upper pipe against the bank of mud or sand which presses against the face of the bulkhead in the shield. The pressure thus created finds an outlet at the lower pipe, along which the current flows back to the shaft, carrying the solid material with it into the river or barge moored alongside the shaft. The two columns of water balance each other, and all the work required of the pump is to overcome the friction in the pipes and at the working face.

In their Bill the company disclaim the use of steam locomotives on their lines, reserving the right to employ any other method of haulage. It is their intention to use rope traction, a method of haulage which is peculiarly well suited to a subway, as it is practically independent of gradients, and enables a uniform speed to be maintained at all parts of the line. The trains will be drawn by endless wire ropes running up one tunnel and down the other from a central motive power station near the Elephant and Castle. There will be two wire ropes; one will start from the engine house, proceed to the City along the "up" and return along the "down" line, while the other will make a similar circuit in the opposite direction to and from Stockwell. The leading carriage of each train will be connected to the rope by a gripper, that is, as *Engineering* explains, by a jaw which can be closed upon the rope by a screw or lever when it is desired to start, and can be relaxed as a station is approached. The rope will travel in the first instance at the rate of ten miles an hour, and the average speed of the trains will be about nine miles per hour, including stoppages at four intermediate stations. The vehicles will resemble tramcars, but will have considerably more head room, while their width, which will exceed by 18 in. that of the second-class carriages on the Metropolitan Railway, will render them very comfortable and convenient for entrance and exit.

The ventilation of the subway is a matter which may be safely left to take care of itself without misgiving, and without any fear of "blowholes" being opened in the streets.

As there are to be no locomotives, the greatest cause of foul air, particularly of sulphurous acid, will be absent, while the constant direction of the traffic in each tunnel will convert the trains into a series of pistons which will maintain an active circulation of air. Even in the large tunnels of the District Railway a train pushes an immense quantity of air before it, and produces a partial vacuum behind it; unfortunately the opposite services greatly neutralise each other's good effects.

The cost of the new subway is estimated at 550,000*l.*, including land, buildings, stations, and rolling stock; not a great sum for a railway, but yet many times larger than would be required for an equivalent length of tramway. To pay 5 per cent. on the capital, there will be required, after all expenses have been paid, the sum of 27,000*l.* per annum, raised by fares of 1*d.* and 2*d.*, according to the distance traveled. Already a part of the route traversed by the subway is covered with an extensive system of tram lines, and from their published accounts we find that the average annual earnings per mile are about 14,000*l.* Consequently if the subway is no more successful than its competitors overhead it will take 46,500*l.* per annum, which would provide 19,000*l.* for working expenses and 27,000*l.* for dividend, a very fair division. One need not be very sanguine, however, to indulge the belief that the underground traffic will greatly exceed that of the trams, as on the north side of the river. In the first place, the vehicles will run at double the speed, and will make fewer stoppages; they can be grouped together in trains to increase their carrying capacity. But apart from these comparisons which are intrinsic to the two systems, the tramway in South London has special disabilities from the fact that it terminates three quarters of a mile short of the City. Here the passengers are obliged to alight, and to make the rest of their way on foot in a miscellaneous throng along the most crowded thoroughfare in the world. If the weather be bad there is no other choice than walking or taking a cab, for the omnibuses are full long before this point is reached, and even if they were not, their progress is quite as slow as that of a pedestrian. There is, of course, the alternative of taking an omnibus the whole distance, but often it is impossible to find room. When the subway is finished, a resident in Clapham-road will have the choice of traveling by tram for half an hour, and then walking a considerable distance into the City, or of descending to the subway, and of being transported right into King William Street in twenty minutes for the same outlay of 2*d.* At present there is no means of traveling into the district besides omnibuses and trams.

If the present undertaking proves a success, there is no doubt that projects of the same kind will be rapidly set on foot for other parts of London, and that there will result a great improvement in our means of communication. This would prove a boon to the shopkeepers, as it would enable people who can not afford cabs to make the journey to Oxford Street and Tottenham Court Road without enduring the purgatory of half an hour's ride in an omnibus. If ladies, for it is they who do the greater part of the shopping, could be carried rapidly from shop to shop, it would do more to arrest the growing supremacy of co-operative stores than any agitation the retailers can raise.

The office of the company is at 62 King William St., E. C., London. Sir John Fowler is the consulting engineer; Mr. J. H. Greathead, C. E. (8 Victoria Chambers, Westminster), is the engineer-in-chief; Mr. W. J. McCleary is resident engineer, and the secretary is Mr. H. H. M. Smith.

GEN. A. K. STILES.—The venerable and dignified figure of Gen. Anson K. Stiles, of Chicago (of the Van Depoele Company) was conspicuous in the Astor corridor yesterday, and enjoys the distinction of being a prominent figure on the canvas of the Monitor and Merrimac panorama. He is about 60 years old, white-haired and as straight as an arrow.—*Evening Sun*, New York.

*The Cable System*, as operated by the Chicago City Railway Co., is briefly described by Mr. H. H. Windsor (the company's secretary), in a handsome souvenir pamphlet.

## Rapid Transit Facilities in New York and Boston.

BY FRANCIS E. GALLOUPE.

That there is a strong and growing demand for some substantial progress to be made in improving the present means of caring for the passenger traffic of every great city, is beyond question. Many seem to think that by the consolidation of the street horse railway lines the existing evils will be destroyed, but all are agreed that, unless something is done, more radical departures will soon occur, and the speedy introduction of a system of elevated railways or of tunnel lines, one or both will take place. The question is of interest to every resident of Boston and its suburbs. Boston is situated precisely like New York in its need of adopting adequate measures to grapple with this serious problem and secure its solution. The result of failing to grasp the situation here, as in New York, is retarding the growth of these cities, and the natural development of their business, while a progressive and comprehensive system for increasing and improving the transit facilities would have the opposite effect, that of stimulating business and the growth of the city, and consequently its increase in valuation. While Boston has been developing the horse railway system to the utmost in order to meet the constantly growing demands, New York has been doing the same with its elevated railway system. Each, in its place, is now found to be inadequate. New York must soon construct an underground railway, to be built where the business of the city is most concentrated, and afterward developed into a system by its extension to form a loop line, or "circle," beneath the city's streets. Boston will have its system of elevated railway lines, which will probably be sufficient to take care of the traffic here for a long time. Consolidation of horse railway lines can not touch the essential requirements of the problem, and will result, at the best, in but a temporary improvement.

It is the present purpose to state the situation in New York and Boston in regard to the rapid transit problem, and to show that the statistics of travel lead irresistibly to the conclusions just expressed.

### FACILITIES IN NEW YORK CITY.

New York is about 14½ miles long, and, on an average, 13¼ miles wide, comprising about 25 square miles of area. Of houses there are 100,000, the population averaging 13½ persons to a house. The population of New York, in 1881, was 1,243,000; that of Brooklyn (for the suburban places should be considered in connection with the city) 566,663; Jersey City, 120,722, and Hoboken, 31,000; a total of 1,962,300. The increase in the 10 years from 1870 to 1880 of the first three of these cities has been 472,747, or 33.27 per cent. At the present time the population in and around New York is not less than 2,250,000. As in London, New York residences have been forced far from the business centre to many miles up town or in the adjacent cities, creating a great tide of daily travel to and from the business centre, for which means of transit had to be provided. Elevated lines of railway built of iron were suggested, and an experimental line about one-half a mile in length was built in Greenwich street in 1866, it being the intention to operate the road by wire ropes run by stationary engines. This experiment failed. The practicability, however, of safely supporting a railway train upon girders resting on a single line of posts was demonstrated. The New York Elevated Railway Company was formed in 1872, lines built and rapidly extended through the streets, the lines of this and the Metropolitan Elevated Railway Company being now worked together by the Manhattan Company. This company has 32½ miles of double-tracked line and a total of about 84 miles of track. The equipment consists of 266 locomotives and 770 passenger cars. The cost per mile of double track, including stations, of which there are three to a mile and double, there being one for each side of the street, is as follows: Permanent way, \$280,676; stations, \$58,380; five locomotives, \$19,440; 12 cars, \$37,363; being a total of \$395,894, or in round numbers, \$400,000 per mile. The fares are now uniformly 5 cents. The speed between stations was formerly about 20



miles per hour, averaging, with stops, about 12 to 14 miles, but owing to the enormous growth of the traffic and the increase in the number of trains, which run every two minutes in the busiest portions of the day, the average speed at present is hardly more than nine miles per hour.

THE GROWTH OF TRAFFIC

on the elevated roads has been as follows: In 1872, the first year, when 3½ miles only were operated, the number of passengers carried was 137,446, and the gross receipts, \$3,745. In 1886, 32 miles of main line were operated, the number of passengers carried was 115,109,591, and the gross receipts, \$7,352,982. The aggregate number of passengers carried during this interval was 692,929,878, and the gross receipts, \$48,429,187. The operating expenses now average about 61 per cent. of the gross earnings.

The horse railway lines of New York are about 125 miles in extent, and have 246 miles of track, employing 15,061 horses and 2,063 cars. They carried in 1886, 210,030,484, the total traffic of New York being 325,149,075 passengers, in 1886.

The following table shows the increase of the traffic:

	Passengers.
In 1855, 4 railways carried.....	18,488,459
In 1860, 6 railways carried.....	36,455,242
In 1865, 12 railways carried.....	82,054,516
In 1875, 19 railways carried.....	166,918,173
In 1886, 25 railways carried.....	325,149,075

So far from the elevated roads diminishing the traffic of the horse railroads, it is the fact that five of the latter roads carried in 1886, 116,864,443 passengers, or 1,754,852 passengers more than the four elevated roads. The important fact is thus brought out by the experience in New York that the amount of travel on city railroads increases in proportion to the facilities furnished.

To measure the effect of increase of facilities, and in further proof of this, the increase of real estate valuation as well as increase of population may be taken. The following table shows in a striking manner the effect of all improvements in transit facilities upon the valuation of property. The period between 1876 and 1879, being that in which the rapid transit system of the elevated roads was in its infancy, is compared with the four years from 1881 to 1884:

	Valuation.	Increase.	Per cent.
1876.....	\$392,428,165		
1879.....	918,134,380	\$25,706,215	2.8
1881.....	976,735,199		
1884.....	1,119,761,597	143,026,398	14.0

In 1850, the population above Fourteenth street was but 113,344, and the centre of population one mile north of City Hall, or two miles from the Battery. In 1880, it was 604,851 and the centre of population three miles. To-day it is nearly four miles, and by 1896 it will be five miles. Furthermore, while 30 years ago each inhabitant rode in the cars on an average but 12 times per year, this number has increased to over 200 times for each inhabitant. The average increase in the number of passengers each year is not far from 20,000,000, and it could be readily shown by statistics that not only does the travel increase with the natural growth of the city, but that the rate of growth of the travel as well as the absolute growth increases, while also the average length of the trips increase. These considerations show the difficult nature of the problem. If the passenger traffic be divided into short distance and long distance travel, it will be found that while the former grows only with the natural growth of the city, the elevated lines, which only can supply the means for long distance travel, have practically to take this entire increase. The demand for transit facilities is doubling in about every 10 years, while the great bulk of the last named traffic is concentrated wholly upon the elevated or long distance lines, so that the elevated railroads find the demand upon them to be doubling every five or six years.

Now, in what condition are the elevated roads to meet these requirements? They have a structure designed only to carry locomotives of very light weight, and they have increased this weight to 22 tons per engine which is all the weight that the structure will safely bear. The heavy traffic demands to-day more power than engines

of this weight can supply. An engine of this weight has 17 tons weight upon its four driving wheels, and can exert a constant pull of but one-fifth this weight, or 6800 pounds, to draw the train. This tractive force is just sufficient to draw five loaded cars up a 2 per cent. grade at six miles per hour. The cars weigh 11 tons and have 49 seats each. It is common to carry 110 passengers in a car, making use of standing room in aisles and on platforms, and, these at 150 pound each, would be a load of 8¼ tons, making the total weight of a loaded car about 20 tons. The train of five such cars, therefore, weighs about 100 tons, and this weight of train can not be increased with the present motive power.

The only way left open is to increase the number of trains and diminish the speed. Rapid transit is disappearing from the elevated lines, and so slow has it already become that it is now thought that cables will have to be substituted for the engines in order to convey the traffic, and to pull heavier trains. The loss of time now endured is very great. The average distance to a ride is about three miles, and at an average speed of nine miles per hour, it would require 20 minutes to a trip, or three trips would consume an hour; 325,000,000 trips would equal 108,300,000 hours, or 12,930,000 days of nine hours each. At 300 working days to the year, the time expended in travel is over 40,000 years. Valuing this time at \$2 per day, its cost to the residents of New York is \$24,000,000 annually. Could one-half of this be saved by doubling the speed of transit, it would be equivalent to a money value of \$12,000,000, or sufficient in a single year to construct the means by which it can be secured. As the population becomes further extended, the average length of trips and the time required are proportionately increased. The number of passengers per day is now 383,000. What is to be done when this number has increased to 500,000? The remedies proposed are,

First, an entrance to the city by means of an eight-track railroad bridge over the Hudson, between New York and Jersey City, and elevated 150 ft. above the water, to clear the shipping. Such a structure would cost at least \$15,000,000, or about the same as that of the Brooklyn bridge. The ferry trips would then be reduced from 2000 to 500 per day, and the 150,000 people crossing the North River daily, could be brought by train over this bridge, the tracks of which would, of course, connect with the great railroad systems of the country. On the other side of New York, the latest report of the Brooklyn bridge shows a passenger traffic of 27,047,984, for the year ending Dec. 1, 1886, the gross receipts from which were \$743,539.

Second, the Broadway underground railway, or the Arcade railway plan. By this plan it is proposed to excavate Broadway between the curbstones, or for a width of 44 feet, building solid masonry walls directly beneath them, extending as far down as the foundations of the buildings and vaults. Four tracks are to be laid, the two central ones being used for long distance travel and rapid transit, or for a speed of 35 miles per hour, and the two outer for local traffic. Abutters can communicate with these tracks, if desired, for the shipment of freight, for which purpose the tracks would be used at night. Between these two sets of tracks are iron pillars upon which are carried the heavy beams, 25 feet in length and 30 inches in depth, extending from side to side, for the support of the street above. These cross beams are placed eight feet apart longitudinally. Fireless locomotives are to be employed, which receive their superheated water and steam from fixed boilers at convenient coaling points. All smoke, dust and noise are thus effectually overcome, and the solid foundation and permanent way kept easily in repair and free from snow blockade and other obstructions. Below the outer tracks are galleries for pipeage. The cost of building this road, after very careful study and estimate, including the relaying of the city's pipes, telegraph lines, etc., and with equipment, will be about \$3,000,000 per mile. The equipment alone is estimated at \$300,000 per mile, included in the above sum. About six miles is projected, from the battery extending under Broadway to Forty-second street, or Central Park. The total cost of this section would be \$18,000,000. Its capa-

city would be over 900,000 passengers per day. Eventually extended, this plan would form a loop beneath the city some 18 miles long. Connections would be made through the Hudson River tunnel with the great railway systems east and west.

#### BOSTON STATISTICS.

Turning now to Boston, there is little to be said. Transit facilities here are in a state of transition. Although in lesser degree, the same need of increased facilities and for rapid transit exists. Consolidations are taking place, the results of which can not now be anticipated. The population of Boston in 1880 was 362,839; Cambridge, 52,669; Brookline, 8,059; Chelsea, 21,782; a total of 445,347. In 1870 the total of these same places, or of Boston and its suburbs, was 315,357, there being thus an increase in 10 years of 41.22 per cent. The population to-day of Boston and its immediate suburbs is probably 600,000. In extent, 12½ miles long by about 1½ in width, its area is about 27 square miles. Its valuation is over \$1,200,000,000. There are nine railway terminal stations in the city, and, within a radius of four miles from the City Hall, 101 stations. There are 210 miles of street railroads in Boston, and so great has been the development in this direction that a passenger can ride, in going from Forest Hills or Jamaica Plain, on the south, to Marblehead, on the northeast, a distance of about 21 miles, by horse car. Three thousand trips are made per day. The increase in the passenger traffic has been about 40 per cent. annually, or, on an average, 2,500,000 per year. The value of the horse railway lines is \$12,916,320; the gross receipts in 1886, \$3,940,854, or an average of \$18,725 per mile, or nearly double the gross earnings per mile of all the steam railroads of the State. The operating expenses were 82.67 of the gross earnings. The number of employees is 3,907; horses, 8,871; cars, 1,761. The number of miles run was 14,048,234, and number of passengers carried 79,122,714. This 80,000,000 of passengers now carried yearly in Boston is about what the New York traffic was in 1865. In other words, Boston is about 20 years behind New York in this respect, and the problem of New York to-day will be that of Boston in 1905, or nearly 20 years hence. An elevated railway upon the Meigs' plan, having a single iron girder, supported upon a line of posts, has been chartered, and is to be constructed between Cambridge and Boston. Other forms proposed are the Riley and Enos systems. These systems have for their object the minimizing of the obstruction of the permanent way in the street, combined with an increase of safety from derailment. It is apparent that some one or more of these methods must be looked to for the fulfilling of the conditions necessary, that the needed improvement in transit facilities shall be made, or before a safe increase of speed shall be possible.

The Sprague experiments on the 34th Street Branch are for the present terminated, partly because of the difficulties attending the use of the present central station, which is equipped with old style machinery and was but a temporary make-shift, and partly because the 34th Street Branch is so short that many of the problems that are involved in distance, and which can only be settled over a longer line, can not be there illustrated.

PROPOSALS are solicited by the City Council of Socorro, New Mexico, for the franchise of a street railway to run from the Santa Fe depot to a point near the Billing Smelter, about two miles, more or less, in length. Proposals must state length of time for which franchise is to run, and rates of fare as well as other necessary requirements. A bond, to the City of Socorro in the sum of five thousand (\$5,000) dollars will be required from the successful bidder for the construction of the road within one year from the date of agreement. The City Council reserve the right to reject any or all proposals. R. McCuison is Chairman of Public Grounds and Building committee.

THE spirit of invention is as active as ever; and new street railways are projected in every direction.

## Patents.

The following list of recent Patents relating to Inter-mural traffic is specially reported for the STREET RAILWAY GAZETTE by Wm. C. Henderson, Solicitor of American and Foreign Patents, 925 F Street, Washington, D. C. A copy of any of the following will be furnished by him for 25 cents.

*Issues of the month of June, 1887.*

- 359,761. Apparatus for ventilating railway cars—H. R. Adams, Boston.
- 359,802. Cable railway—E. O. McGlauffin, Minneapolis.
- 359,854. Railway cross tie—H. C. Draper, Oswego, Kans.
- 359,607. Electric railway—I. W. Heysinger, Philadelphia.
- 359,733. Elevated railway—R. T. White, Boston.
- 359,859. Cable railway grip—C. L. Gorrell, Belaire, Md.
- 359,987. Switch for street railways—W. C. Wood, New York.
- 360,054. Car brake—J. C. Schumacher, Chicago.
- 360,062. Automatic car brake—J. S. Sterrett, Philadelphia.
- 360,400. Slack adjuster for car brakes—E. Corson and O. C. Crane, Brooklyn and New York.
- 360,137. Car strap—A. Brandon, New York.
- 360,047. Railway rail splice—S. M. Prevost, Philadelphia.
- 360,397. Railway tie—M. Y. Thompson, Arkadelphia, Ark.
- 364,061. Car starter—H. R. Stickney 2nd, Portland, Me.
- 363,838 and 363,839. Car wheel—G. W. Miller, Kalamazoo.
- 364,192. Swing bearing for street cars—W. Sutton, St. Louis, Mo.
- 364,001. Apparatus for watering railway tracks—J. L. Fisher, Pittsburgh, Pa.
- 364,200. Automatic stop for abutting rails of railways—V. Angerer, Philadelphia, Pa.
- 363,788. Grip apparatus for cable railways—N. Abbott, Kansas City, Mo.
- 364,288. Conduit structure for traction cables—W. Phenix, Chicago, Ill.
- 364,310. Car brake and starter—G. B. Siccardi, New York.
- 364,393. Cable railway car—T. Breen, Knowlton, Pa.
- 364,492. Car spring—N. H. Davis, Philadelphia, Pa.
- 364,286. Car spring—W. C. Perry, Charlestown, R. I.
- 364,511. Car wheel—M. Hardsoc, Ottumwa, Ill.
- 364,502. Street railway rail—E. Feige, East Saginaw, Mich.
- 364,549. Overhead railway switch—E. Samuel and V. Angerer, Philadelphia, Pa.
- 364,500. Conduit for cable railways—E. D. Dougherty, Philadelphia, Pa.
- 364,499. Conduit or brake for cable railways—E. D. Dougherty, Philadelphia, Pa.
- 364,400. Grip carriage for cable railways—J. H. Dale, Philadelphia, Pa.
- 364,488. Grip for cable railways—J. H. Dale, Philadelphia.
- 364,381. Gripper for cable railways—G. W. Stewart, New York, N. Y.
- 364,498. Pulley for cable railways—E. D. Dougherty, Philadelphia, Pa.
- 364,489. Tension device for cable railways—J. H. Dale, Philadelphia, Pa.
- 364,709. Cable grip—W. Dunham, Igo, Cal.
- 364,881. Street car motor—S. W. Wood, Cornwell, N. Y.
- 364,996. Rail chair for street car rails—E. B. Entwistle, Johnstown, Pa.
- 394,939. Car starter—G. T. Jobson, Augusta, Ga.
- 364,626. Switch for overhead railways—V. Angerer, Philadelphia, Pa.
- 364,725. Tongue switch for street railways—A. J. Moxham, Johnstown, Pa.
- 365,669. Suspension wheel for wire cable tramways—R. Prentice, Portage, Wis.
- 365,168. Grip releasing device for cable roads—J. T. Cooney, San Francisco, Cal.
- 365,274. Car starter—B. C. Pole, Camden, N. J.
- 365,273. Triplex motor for street railways—B. C. Pole, Camden, N. J.
- 365,341. Tramway for elevated electric railways with means of insulating the rails—B. F. Hamilton, Boston.
- 365,339. Guide truck for electric railways—B. F. Hamilton, Boston, Mass.



## POINTERS.

## ALABAMA.

*Birmingham.* The East Lake Land Co. have extended their track over the company's property, and have conveyed their road and equipment to the Union Ry. Co. of Birmingham, and the latter company will operate the same in connection with their other lines.

The belt railroad of the Highland Ave. & Belt R. R. Co., which will encircle the city, will soon be completed.

*Mobile.* The Mobile St. Ry. Co. will reduce their gauge  $5' 2\frac{1}{2}"$  to the standard,  $4' 8\frac{1}{2}"$ , the track and switches to be accurately measured. They will add two miles single track and double four miles of their present single track. A large portion of the present track is to be relaid with steel rails, cars will be partially renewed, and a full complement of live stock added.

The Mobile & Spring Hill R. R. Co. will also reduce their gauge to  $4' 8\frac{1}{2}"$ , and they will use dummies on five miles.

## ARKANSAS.

*Little Rock.* The Little Rock St. Ry. Co. intend to relay a mile and half of track with steel rails and make a little extension.

*Pine Bluff.* The Citizens' St. Ry. Co. will soon add two new cars and ten mules, and they will make an extension of a mile or more forthwith, the material having arrived.

## CALIFORNIA.

*Los Angeles.* The Los Angeles Cable Ry. Co. are about to construct ten miles of cable railway. This company was incorporated June 9. The directors are J. F. Crank, I. W. Hellman, Charles Foreman, S. P. Jewett and C. S. Hubbell. These gentlemen at present control the street car system here, and will begin at once to change the principal horse lines to cable roads. They have a capital stock of \$2,500,000—all subscribed. The articles of incorporation call for a total of sixty-five miles of road, including a line to Pasadena, another to Santa Monica, etc. Ten thousand barrels of cement are already on the way.

There is a contract signed to build an electric railway from Los Angeles to Pasadena, via Garbanzo, to be completed by the end of October.

The Temple St. Cable Ry. Co. will extend one and three-quarter miles, and double track a portion of their road.

*Pasadena.* The City Ry. Co., who have three miles of track, are anxious to adopt "anything that is cheaper than mules" on their 4.6 per cent. bill.

The Pasadena St. R. R. Co. contemplate doubling their cars, horses, staples and length of track, and intend to connect with Oakland Park.

The Colorado St. R. R. Co. will proceed to build about two miles more of road, the rails being already ordered. They expect to add more horses.

The Park Place R. R. will soon be in operation.

There is no cable or electric railway in Pasadena yet, "but it is proposed to build some in the near future."

*San Luis Obispo.* Mr. Edwin Goodall has given bonds of \$10,000 to build a street railway in this city according to the terms of the franchise granted, and says the work of construction will be pushed; the tracks shall be completed in first-class style.

## COLORADO.

*Trinidad.* The Trinidad St. R. R. Co. expect to lay a mile additional track and add two cars.

## CONNECTICUT.

*Middletown.* The Middletown Horse R. R. Co. "intend going into electricity."

*Stamford.* The Stamford Horse R. R. Co. are increasing length of road to five and one-third miles, providing twelve additional horses and four additional cars.

## DISTRICT OF COLUMBIA.

*Washington.* The Washington & Georgetown R.R. Co. contemplate adopting the cable system, and will commence operations as soon as they secure the right to do so from Congress.

## GEORGIA.

*Macon.* The Macon City and Suburban St. R.R. Co., contemplate an extension from Post Office corner on Belt Line, out at Second through Oglethorpe Street, into Belt Line again at Tatnall Square Park, distance a mile and half.

## ILLINOIS.

*Bloomington.* The Bloomington and Normal St. Railway, whose sale (May 19) to Messrs. Saddler, Graham and Hursh was reported in the JUNE GAZETTE, was again sold (June 22) by the recent purchasers to J. T. Bailey, a capitalist of Philadelphia, and ex-Senator Patterson of North Carolina, now of Mifflintown, Pa. It is said the price paid was about \$155,000.

*Chicago.* The Directors of the West Division Railway Company held a meeting June 16, and discussed the question of putting in the cable system, but reached no definite conclusion. President Jones said at the close of the meeting: "I understand that the Passenger Railway Company will put a cable through the Washington street tunnel as soon as the Council gives its permission, and that the company is also ready to go ahead and put in the cable system as the details can be perfected." Mr. Jones was asked if this would not necessitate the adoption of that system by the West Division Company, and he replied: "I suppose we shall have to work with them."

President Yerkes came in collision with President Weeks, in their movements about City Hall, and the City Fathers advised them to come to an amicable agreement, as to laying cable tracks on Washington St.

*Elgin.* Two-and-half miles of new track, four cars and ten horses are about to be added to the Elgin City R.R.

*Pontiac.* The Pontiac Street Railway Company has been incorporated; capital stock, \$20,000; incorporators, Reason M. John, George W. Patton, and C. C. Strawn.

## INDIANA.

*Michigan City.* The Citizens' St. R.R. Co. are building two miles of track—to Blair's Springs.

*Mishawaka.* The South Bend and Mishawaka St. Ry. Co. want more cars.

## IOWA.

*Burlington.* The Union St. Ry. Co. will construct about a mile and a half of track as soon as they receive franchise, which they expect immediately.

*Council Bluffs.* Work of laying ties and rails has been commenced, under the instructions of the Hon. J. K. Graves, the builder of the Manawa Motor Railway; and the work has progressed more than half way to Lake Manawa. Two noiseless motors, named "Council Bluffs" and "Omaha," have been shipped from Jersey City, and four cars have been sent from Chicago, and they mean to "get there" as soon as possible.

*Dubuque.* The cable railway, up Eleventh St. Hill, is to be constructed forthwith. A stationary engine and boiler, cars and rails are open for contract. Further information may be obtained from James Forester, Sr., Dubuque.

A horse railway (belt line), nearly 4 miles long, to connect with the inclined cable railway, will probably be built on the bluffs next year. Further information may be obtained from O. E. Guernsey, cashier First National Bank, Dubuque.

*Lyons.* The Clinton and Lyons Horse Ry. Co. are about grading and laying two miles of additional track.

## KANSAS.

*Atchison.* The Atchison St. Ry. Co., who have six and a half miles of track now in operation, intend relaying four miles thereof, and contemplate about a mile and a half extension.

The Belt Line K.R. Co. has been incorporated, by John M. Price and others, to construct a railway from the mouth of Whisky creek below the city to Deer Creek above the line, and will run west of the city three miles, and will offer an additional means of entrance into the city by rail. Another object is to provide facilities for factories on Deer Creek.

*Chase.* Cars for the street railway between this city and Strong were shipped from St. Louis, about June 25.

*Clay Center.* The Cl. C. City Ry. Co. will build four miles more track, add eight new cars, and build new stables. They will adopt either steam or electric motors "within next year." The first part of the line was opened July 4.

No city in the West has more metropolitan conveniences than Clay Center, and this modern street railway places the city away in the lead of all her neighbors, says a local scribe: "Verily this is the favored city of the favored valley of our favored state."

*Dodge City.* The Dodge City Street Ry. Co. has been incorporated. Directors are: J. W. Gilbert, E. E. Soule and W. Munsell, of Dodge City, and A. T. Soule and Wilson Soule, of New York. Capital stock \$100,000.

*Fort Scott.* A new street railway company is being organized to build a line from the Gulf depot along Margrave St. to National Cemetery.

*Great Bend.* The rails for the street railway have arrived.

*Hutchinson.* The Hut. St. Ry. Co. are building 5 miles additional track, which they hope to have in operation Sept. 1st. The steel rails and ties are already purchased. President Forsha has been to St. Louis to purchase new cars, etc.

The city council object to granting a franchise, authorizing an electric railway company to set up wire poles in their streets.

*McPherson.* The street railway here has been opened, to the great delight of the inhabitants. Our correspondent writes: "This is the first of the new enterprises to near completion. The electric lights are close after it. Mr. Bell's new bank building, the water works, and the new high school building will follow soon. Thus McPherson goes on with steady march, no brag, no wind, no bluster, but solid work, and successful work too."

*Newton.* The new building to be used as street car stables, on Broadway, will be of cut stone, two stories high, 66x125. The north end of the building will be used for cars and have a frontage of seventy-five feet. It will have a hip roof, and an elevator will be put in to take cars to the second floor. The company will commence business with three cars, but intend to purchase eighteen.

*Topeka.* The Rapid Transit Company have completed their Jackson street line. "It is double track and is the finest street railway ever built in any city, not even excepting the large eastern cities."

*Wichita.* The Wichita Construction and Supply Co. have closed a contract (June 24) to build 4 miles of extensions for the Winfield Horse Ry. Co., of Winfield, Kansas; and they have also completed the motor line railway for the Rapid Transit Co. of Wichita.

*Winfield.* The Union St. Ry. Co. will add four miles of new track and necessary equipment. President A. J. Thompson.

#### KENTUCKY.

*Lexington.* The Lexington Street Railway Company will build an additional 2½ miles of track.

#### MARYLAND.

*Baltimore.* The Baltimore, Brooklyn and Cedar Hill Ry. Co.—whose present route is from Baltimore city (over Light Street Bridge) to Brooklyn, thence to Cedar Hill Cemetery in Anne Arundel county—propose to build a branch road to Curtis Bay, as well as an extension to the City Hall in Baltimore city.

#### MASSACHUSETTS.

*Boston.* The South Boston Railroad Company have been authorized to locate tracks on Ninth, K, O, Fourth, First, Second, Third, L and Emerson streets and Dorchester avenue, provided that rails be used which are satisfactory to the superintendent of streets; also, that the road-bed inside and for 18 inches outside the tracks be kept in repair.

The Metropolitan Company has been authorized to build a third track on Tremont street, from Sterling street to Ruggles street, also tracks on Lamartine, Centre and other streets in Dorchester and West Roxbury; also tracks on West Lenox street from Tremont to Washington street; also tracks on East Chester Park extension to Swett and

Albany streets; also the right to use electric power on any or all of the above routes.

The West End Company reports that its capital stock is \$80,000, and that work will commence this summer. The company can establish cable and electric systems at its option, providing that the consent of the Board of Aldermen is obtained.

*Cambridge.* At a meeting of the Cambridge city government on June 29th, the following order was adopted, "that the Cambridge Railroad Company be authorized to establish and maintain the electric system of motive power with storage batteries in propelling its cars on the streets, providing, that said company shall not erect poles or stretch wires upon the streets without obtaining authority from the board."

*Everett.* The Selectmen have given a hearing to the officials of the Consolidated Street Railway Company, who petitioned for leave to lay tracks in Broadway and other streets. Several citizens, among them Hon. A. H. Evans, Mr. S. H. Kimball and Mr. Wallis favored the petition. Other gentlemen remonstrated. President Powers of the Consolidated Railway Company stated that he did not propose that the people of Everett shall suffer for horse car accommodations. He proposed, if the petition was granted, to double-track Broadway from its junction with Main street to Everett square, and then run a single track with turnouts up Broadway to Ferry street, and thence to the Malden line, thereby accommodating a large number of people. His company also proposed in the near future to lay a track on Buckman street, from its junction with Liberty and Chelsea streets, and thus do away with the single track now on Chelsea street. The design is to have the Everett and Malden cars go through Buckman street from Everett square, rather than by the present route. President Powers also stated that in a few days the six-cent Everett fare would be reduced to five cents, but there would be no reduction in the fare to Woodlawn. Also if the petition is granted five cars will pass Everett square every hour. The Selectmen took the matter under advisement.

*Fitchburg.* The Fitchburg St. Railway Co. will put on two or three additional cars.

*Medford.* The new line of the Boston Consolidated Street Railway Company, between Medford Centre and West Medford, was opened on June 30th.

*Mill River.* The Kankaport Valley R.R. Co. has been partly organized. R. LeLaft, President, H. D. Sisson, Sec.

*North Adams.* The Hoosac Valley St. Ry. Co. contemplate making connection with the Fitchburg yard at North Adams, and carrying freight to Zylonite and Adams.

#### MICHIGAN.

*Detroit.* The Detroit Electric Ry. Co. expect to enlarge their plant generally.

*Fort Gratiot.* The officials of the Gratiot Electric Ry. Co. are the same as those of the Port Huron Electric Ry. Co., with whose terminus the new line is to be connected.

*Port Huron.* The Port Huron Electric Railway will add two summer cars to equipment this month.

#### MINNESOTA.

*Stillwater.* The Union Depot St. Ry. and Transfer Co. are building a new depot.

#### MISSISSIPPI.

*Natchez.* Thos. Reber, owner and manager of the Natchez St. Ry. will probably build a mile and a half of track this year, in addition to the 2¼ miles now in operation. Mr. Reber writes, July 6: "This is the best town south for either residence or business. It looks as if we were going to have a railway to Fort Scott, and others in several directions; when they come the city will grow very fast. We now have over 10,000 population."

#### MISSOURI.

*Hannibal.* The Hannibal St. Ry. Co. have put in half a mile of double track, making a total length of 2½ miles.

*Kansas City.* The Metropolitan St. Ry. Co. are about to add ten grip cars and ten passenger cars for their Wyandotte extension (about two miles) of the Fifth Street cable line. They are also building a line on 12th St., about 4¼ miles long, which they hope to have in operation early next winter. The total mileage of the Metropolitan lines is about



12 miles, out of which about  $4\frac{1}{2}$  miles will be taken up and converted into cable railways during this year; and they will build an additional length of  $2\frac{1}{2}$  miles, double track cable mileage, which will make a total of about  $14\frac{1}{2}$  miles at the end of this year.

The Grand Avenue Ry. Co. are just completing their  $14\frac{1}{2}$  miles of cable track, and removing 4 miles of their horse car track to another street. They will use the Root combination cars. It is expected all will be completed and in operation by September 1st.

The Kansas City Cable Ry. Co. have ordered 21 more coaches and 12 new grip cars.

The Kansas City Electric Railroad Company is running cars regularly over the entire length of the road. The cars are crowded with passengers enjoying the novelty of riding on cars propelled by electric motors. The cars run forward and backward with ease and the speed is accelerated or decreased as gradually as may be desired. The run up the hill near Forest avenue is accomplished with great facility. The new machinery put in by the company gives the utmost satisfaction. Nearly all the buzzing sound produced by the old machinery has been eliminated.

The Inter-State Rapid Transit Railway Company Consolidated, the Kansas City and Wyandotte Railway and Tunnel Company, the Riverside Railway Company, and the Brighton Hill and Chelsea Park Railway Company have been consolidated under the name of the Inter-State Consolidated Rapid Transit Railway Company. The place of business is in Kansas City, and the capital is \$1,400,000. The officers of the new company are the same as those of the Inter-State Rapid Transit Company. This makes a powerful company, and the various branch roads of the corporation have and are doing a great deal for the development of the city.

A pair of mules drawing a street car were galloping down the Southwest boulevard at a very lively rate about 9 o'clock at night recently, and had reached the Gates addition when the driver was completely dumbfounded by observing them suddenly sink into the earth and out of sight. Before he could set the brakes the car had passed over the place where they had been lost to view. When the car stopped he proceeded to institute search for the missing animals. A few steps back over the track the car had traversed brought him face to face with them. They were standing in a sewer, which had caved in where the tracks passed over it, and only their heads were out of the water. They were extricated from their position with considerable difficulty.

The Woodland Ry. Co. has been incorporated by Thos. S. Ridge, and others; capital \$60,000. Mr. Ridge says: "We have organized to operate a cable line on Woodland avenue. The line will run on Woodland from Springfield avenue to either the Ninth street or the Fifteenth street line. Both the Grand avenue and the Metropolitan companies have put in bids for the carrying of our passengers, and neither will object to the granting of the franchise. We promise to have the line in operation two years after the granting of the franchise."

*St. Joseph.* The Wyeth Park Ry. Co. has been incorporated, with a capital of \$300,000, to construct the Olive St Cable line, etc. The stock has all been subscribed and paid up, and the incorporators say they will begin work as soon as the common council grants the necessary right-of-way. The property owners along the proposed route have signed the petition for the cable almost unanimously, and are heartily in favor of the scheme.

#### NEBRASKA.

*Hastings.* The Citizens' St. Ry. Co. has been formally incorporated. The capital stock is \$100,000. The incorporators are Henry Shudd, R. S. Batty, C. L. Jones, D. S. Cole and M. L. Alexander.

*Lincoln.* A movement toward securing still another street car line for the southwestern part of the city has been inaugurated. The road will run from Tenth street to First on South, thence through the Cadman property and toward the penitentiary. Stock is being subscribed rapidly, and the projectors of the enterprise are very confident that the

road will be built at once. It is understood that D. L. Graham and Mr. Bronson of Riverside are the most prominent of the syndicate pushing this road.

*Omaha.* The Cable Tramway Co. of Omaha have four miles of cable road (double track) in course of construction, as well as power buildings and equipment. They will commence operations with 15 grip cars and 20 passenger cars.

*Wymore.* The Wymore and Blue Springs Ry. Co. contemplate an extension of one mile.

#### NEW JERSEY.

*Asbury Park.* An adjourned meeting of the City Fathers was recently held at Park Hall to consider the much discussed street railway matter. The only bids for the franchise received by the commissioners were those of Henry S. Iselin and Samuel T. Dunham, who represented the Daft system of electric railway, and the Asbury Park Street Railway Company, representing the Van Depole system. The former company offered \$3,000 a year for a term of twenty years for the franchise, and the latter company offered 5 per cent. of the gross earnings of the road, provided the earnings exceeded 5 per cent. on the capital invested. After an extended meeting the commissioners virtually concluded to accept the bid of the Daft men, but decided to advertise both bids and routes for two weeks, when the franchise would be given.

*Hoboken.* The North Hudson County Ry. Co. will extend their elevated cable road.

#### NEW YORK.

*Binghamton.* The Washington St. and State Asylum Electric R.R. has been running motors nine weeks, and will increase rolling stock, put in 40 lbs. steel rail, and build new car barn. They have two grip cars, with 40 hp. engine. Their electric portion is the Van Depole system, with 100 hp. engine. Number of passenger cars 14.

The Binghamton Central R.R. Co. contemplate an additional mile of track.

*New York.* The Arcade Railway Co. have completed financial arrangements to raise necessary capital to construct the first section of their four-track underground railway, about six miles in length, running from the Battery, under Broadway, to Fifty-ninth street, with a branch from Madison Square, under Madison avenue, to the Grand Central Depot.

The projectors promise that within a few months one mile of Broadway will be tunneled from curb to curb, and that within two years the entire six miles of the first section shall be completed. "Everybody concedes that increased rapid-transit facilities are an absolute necessity," says a New York contemporary, "and this method will allow of water, gas, and steam pipes being placed where they can be repaired without tearing up the street."

The Central Park, North and East River R.R. Co., whose great fire was reported in our last issue, propose rebuilding their depots and stables at once, and will rehabilitate the road as rapidly as possible.

There is no intention on the part of the Daft Electric Motor Company to abandon the experiments on the Ninth Avenue Elevated road. The manner of conducting the electricity has been changed somewhat. Instead of using a third rail to convey the current into the motor, a wire has been placed just outside of the railroad tracks. This is perfectly isolated and conveys a stronger current than the rail. "Our motor is all ready," Manager Hawksworth said the other day. "The wire has been laid on the down track, and men are busy placing it on the up track from Fourteenth to Fifty-third street. We showed by our first experiment a year ago that the motor was practical. Now in a few weeks we expect to demonstrate that our motor will handle five heavy cars as easily as it did two in the former experiments."

It is said that the reason given by Governor Hill for not signing the bill of the Suburban Rapid Transit Company was that he had not time to examine into its merits in the thirty days prescribed by law.

The following Board of Directors of the Broadway and Seventh Avenue Railroad Company has been elected:

Charles Banks, William B. Dinsmore, Bernard M. Ewing, John H. Murphy, Thomas J. O'Donohue, Thomas F. Ryan, John J. Bradley, William T. Elkins, Charles F. Frothingham, D. B. Hasbronck, W. H. Rockwell, Henry Thompson and Peter A. B. Widener.

Colonel Rowland R. Hazzard, of the Underground Railway Company, has set at rest the suspicions which had been afloat relative to the new Rapid Transit Commission appointed by Mayor Hewitt, which consists of General Louis Fitzgerald, Peter B. Olney, Stevenson Towle, Thomas C. Clarke and James B. Smith. The Underground Railway Company is responsible for the application for this commission and its purpose is to secure a straightening out of its Elm street route and to put in place of its route in City Hall Square another to extend from Centre street down Park Row to a point opposite the Astor House at Broadway.

#### NORTH CAROLINA.

*Charlotte.* The Charlotte St. Ry. Co. are extending their track three-quarters of a mile, which will be completed shortly, and then two new cars and ten (or more) mules or horses will be added.

*Raleigh.* The Raleigh St. Ry. Co. intend to extend their road about one mile, to reach State Fair Grounds and suburban village of Oberlin.

#### OHIO.

*Cincinnati.* The Columbus and Cincinnati St. R.R. Co. have rebuilt dummies and relaid track with new rails.

*Cleveland.* The Broadway and Newburgh St. R.R. Co. are building new horse barns and car-house.

*Dayton.* The Oakwood St. Ry. Co. have just added seven new cars.

The Dayton Street Railway Co., will adopt electricity "as soon as the storage battery system is proven a success."

#### PENNSYLVANIA.

*Allegheny.* The Federal St. & Pleasant Valley Pass. Ry. Co. will lay 1,600 feet of new track.

*Beaver Falls.* The Beaver Valley St. Ry. Co. have added a new summer car "for extra occasions," and they are paving their entire line with brick.

*Philadelphia.* When the selectmen recently visited Boston for the special purpose of examining the construction of the plant and investigating the claims of the Meigs elevated railway system, it was generally understood that the visitors were loud in their praise of all they were shown, and it was also generally understood that Philadelphia was to have an elevated railway on the Meigs system at an early day. It appears now that there will be no elevated railway in this city the present year. The Select Council have indefinitely postponed the whole matter by an overwhelming vote. Mr. Wanamaker, the president of the Consolidated Transit Company, had previously withdrawn the application for a franchise. The citizens held a mass-meeting to protest against elevated railroads in general and that of the Consolidated Transit Co. in particular.

An interesting exhibition of a street car propelled by electricity from storage batteries placed under the seats was given recently by William Wharton, jr., & Co., at Twenty-fifth St. and Washington Av. The car used was an ordinary horse car. The batteries were manufactured by the Electrical Accumulator Company of New York, and consist of eighty-four small cells, each being of the size of about one-quarter of a cubic foot. The track upon which the car is run is 1,000 feet in length, with four curves, one of which has a radius of 33 feet, considerable more than a right angle. Immediately upon leaving this curve a gradient commences with a rise of 5 per cent. which is equal to 264 feet per mile. The exhibition was eminently satisfactory in all respects.

*Pittsburgh.* The Second Av. Pass. Ry. Co. contemplate electric traction. They are also about to build six miles of new track.

The Pitts. & West End Pass. Ry. Co. opened their 2½ miles extension July 4th, with elegant new cars, etc.

*West Hickory.* The Hickory Valley Railroad Co. has been incorporated; capital, \$50,000. It will run from West Hickory to Camp Run, a distance of five miles.

*York.* The York St. Ry. Co. will make an extension of one mile, and add three cars together with eleven horses.

#### SOUTH CAROLINA.

*Charleston.* The Enterprise RR. Co. expect to extend their lines the ensuing fall.

*Greenville.* The St. Ry. Co. of the City of Greenville, have finished relaying about three-fourths of their entire track—ballasting with rock.

#### TENNESSEE.

*Athens.* The Athens Mineral Land and Improvement Co. will make very extensive improvements in their street railway, at once. They have only a mile of track at present.

*Chattanooga.* The City St. R.R. Co. are extending their new line to Lookout Mountain, 2½ miles, and building west of 9th and Grove streets (about one mile), and they will extend the Vine street line about half a mile.

*Memphis.* The Citizens' St. R.R. Co. have completed six miles of new track, and will receive rails for two miles further extension by the beginning of August.

#### TEXAS.

*Gainsville.* The Gainsville St. Ry. Co. will add two summer cars and three more switches.

#### VERMONT.

*Rutland.* The Rutland St. Ry. Co. "would like to adopt electricity as power—if they were satisfied in regard to the matter, and if it could be adopted without too much expense." Well, according to their faith be it unto them.

#### VIRGINIA.

*Danville.* The necessary stock has been subscribed, says *Dixie*, for building a street railway in Danville, Va.

*Lynchburg.* The Lyn. St. Ry. Co. have added three cars, and they contemplate an extension of half a mile. They are also investigating electric motors.

*Richmond.* The Union Pass. Ry. Co. are about to appoint a new superintendent.

#### WISCONSIN.

*Eau Claire.* The Eau Claire St. Ry. Co. have constructed an additional mile of track, making the total 4½ miles, and they expect to make more extensions in the near future.

*Janesville.* The Janesville St. Ry. Co. have built an extension of a mile and three-fourths.

*Madison.* The Madison St. Ry. Co. may probably sell its road, equipment, franchise, etc., in the near future; and if the road changes hands, as anticipated, electric power will be adopted.

*Milwaukee.* The Cream City RR. Co. are building a double track on East Water Street, crossing Huron Street Bridge, to the new C. Mil. and St. Paul Ry. passenger depot—about 2,000 feet in length.

The capital stock of the Milwaukee Cable Railway Co. is \$300,000. Wm. P. McLaren is one of the incorporators.

#### CANADA.

*Brantford, Ont.* The Brant St. Ry. Co. contemplates ¾ mile new track.

*Niagara Falls, Ont.* The Niagara Falls, Wesley Park and Clifton Tramway Co. will build about half a mile of cable railway, where the grade is too steep for horse-power, using a stationary engine of 16 hp., with additional cars suitable for the purpose. They will also build an extension of their line across the Suspension Bridge over Niagara River.

*St. Thomas, Ont.* The St. Thomas St. R.R. Co. will construct about quarter mile of new track, and add one new car, with several horses.

#### MEXICO.

*Monterey.* The Monterey and Santa Catalina Ry. Co. contemplate an addition of six passenger cars and thirty more mules, and will build car sheds and stables for 85 mules.

#### ENGLAND.

*Bristol.* The gradients at Bristol are very severe, several lengths of 1 in 13 and 1 in 15; and a large number of trace horses are employed. The Bristol Tramways Co., Limited, will doubtless shortly apply for parliamentary sanction to use cable traction on one or more sections.





trough, the side pieces, G, thereof being preferably of iron, thereby providing sufficient strength and rigidity to enable the conductor to support itself in the intervals between the cross-ties. The iron side strips, G, are securely and permanently attached to a copper bar *g*, which forms the lower portion of the grooved conductor. This composite conductor is carefully covered on its three outer sides by insulating material H, which is preferably formed of stout fabric soaked in bitumen or other insulating substance. The blocks E (themselves insulators) are grooved along their central portions for the reception of the insulated composite conductor, which is firmly secured in said groove in a position extending slightly above the blocks E, which are sloped off toward the sides of the conduit, so as to form gutters *e'*, adapted to carry moisture away from the center, ultimately discharging it into the drain below, either through the drip-holes *e* or over the ends of the blocks E, as described.

In order to prevent moisture—such as rain and snow—from entering and filling up the grooved conductor, a cover is provided, which consists of continuous strips of flexible material, I, which are secured one on each side of the conductor, so that their upper edges will come together, forming a continuous roof or cover therefor, which will be easily forced open by the passage of the conducting-arm depending from the moving vehicle, and thus close automatically after it has passed. These strips should be protected at their upper edges by a facing of steel, *i*, so that the friction of the contact arm will not destroy them. In fig. 2 is shown a modification, in which the roof I is stationary, being fixed at one side of the conductor and extending obliquely thereover, so that anything falling through the slit *b* would be caught by said roof and carried to the gutter *e'* on one side. With this construction the contact-arm *h* is curved after its entrance into the conduit, so as to pass around the edge of the roof and then back toward the center until its lower extremity is directly under the slit *b* and the contact-brush carried thereby in working position in the grooved conductor.

In fig. 3 is shown a form for the sides of the conduit, which admits of a more ready construction of rolled iron or steel. In fig. 4 two conductors are shown set at such an angle that they may be conveniently placed at the sides of the conduit, leaving the center clear for the reception of the water falling through the slit *b*. The presence of two conductors of course dispenses with the use of track as a return, which is the usual arrangement, and preferable on the score of economy. In fig. 5 is shown another arrangement. This is also for a single conductor, which, on account of the shape of the conduit, is placed entirely under one side thereof, and in that manner escapes the drip from slit *b*.

In fig. 6 a further modification is shown, by means of which the conductor may be placed with its groove in a horizontal instead of a vertical position. This of course most effectually prevents the entrance of water therinto, and it will be obvious that this arrangement might also be applied to the form of conduit shown in fig. 3, one conductor being secured on either side. With any or all of these constructions, the construction of the roadway remains substantially the same, the drain F being provided to carry away the water entering through the slit *b*, and the space between the cross-ties, the sides of the conduit, and the rails being filled with suitable material—such as broken stone and concrete—and in the case of a city street topped off with a surface of asphaltum, which rises toward the center of the track, making it sufficiently higher to deflect all moving water toward the rails and away from the open slit. The expansion-joint J is used wherever it may be found necessary to secure the integrity of the system, and the side walls, D, D, whether of cast or wrought iron, when lapped, as shown in fig. 7, and bolted or riveted together, impart to the conduit as a whole the greatest possible solidity and permanence.

Suitable openings should be provided at points along the roadway, whereby access can be had to the conduit.

The VanDepoele Electric Manufacturing Co. have several other patents now pending for different construction and improvements in underground conduits for electric railways; they also have the first patent granted in the United States on this subject.

## The "Lyver" System.

A SHORT DESCRIPTION OF PAVEMENTS AND MODE OF LAYING TRAMWAYS ACCORDING TO THE "LYVER" SYSTEM, AND AS EXECUTED BY THE CITY OF LIVERPOOL, ENGLAND.

### FOUNDATION.

The Carriageways are excavated to a depth determined upon, as the work proceeds, by the depth of pitching or other hard foundation which exists underneath the original pavement. A bed of Portland cement concrete is then formed to within seven and a half inches and six and a half inches respectively of the finished surface of the street, and this concrete is carefully finished off to the exact cross section of the finished road-way. The concrete is composed of one part (by measure) of gravel and eight parts (by measure) of broken stone.

The cement mortar is mixed as follows: A cubic foot of gravel (by measure) is tipped on to the mixing board and a quarter of a cubic foot of cement (by measure) added; the two materials are then turned over with a shovel until thoroughly mixed and incorporated; sufficient water is then turned on, through a hose, and allowed to flow over the material, which is then constantly turned over, special care being taken that only sufficient water is added so that the dampness of the material is such that when a small portion is taken in the hand, and pressed, it will only just hold together.

### PERMANENT WAY.

On the bed prepared for the concrete foundation, moulded blocks formed with Portland cement concrete, of about eight inches square at the base, are laid with their upper faces on a level with the under side of the sleepers when the latter are fixed in position. The sleepers are then laid on these blocks, the rails being placed on them, and the wrought iron jaws secured to the rails and sleepers by bronze bolts and wrought-iron nuts. A space of about a quarter of an inch is maintained between the upper surface of the jaws and the underside of the rail by means of temporary wrought-iron split washers. The rails and sleepers having been correctly laid as regards level and position in roadway, gauge etc., the concrete foundation is then proceeded with. After the foundation has become "set," the bolts are unscrewed, the temporary washers removed, the bolts replaced and the rails and sleepers firmly screwed down to the jaws, which have then become firmly bedded in the concrete foundation. The recesses or hand holes are then completely filled in with plastic pitch which surrounds the nuts and thus prevents them from turning around.

The jaws and fastenings are three feet from center to center, except at the ends of rails, where they are nine inches from center to center. The points and crossings are of annealed crucible steel, roughened on exposed surfaces, and secured to special cast-iron sleepers in a similar manner to the Bessemer steel rails, except that a layer of roofing felt is laid between the points and crossings and their respective sleepers. The sleepers are filled with Portland cement concrete up to the level of the underside of the rails, and the recesses for the jaws filled with plastic pitch, completely surrounding and holding in position the wrought-iron nuts.

### PAVEMENT.

Between the rails, and for eighteen inches on either side of the same, the roadway is paved with syenite sets (Belgian blocks), the sizes varying according to circumstances. These sets are squared throughout, accurately gauged, and laid in regular straight and properly bounded courses, and evenly bedded on a layer of fine gravel, not exceeding half an inch in thickness. After paving, the joints of the sets are filled with fine, clean, dry shingle, rammed well and refilled and then carefully grouted with hot pitch and creosote oil of the best quality. Along each side of the rail is laid a course of alternately long and short sets, accurately gauged and squared and specially dressed. All these materials are subjected to a severe physical test, and all that there may be any doubt about are promptly rejected.

I append a scale of wages paid the workmen, and prices of materials as paid by the Liverpool corporation:—

Rate of wages paid (day work):—Platelayers, \$1.25 to



\$1.00; blacksmiths, \$1.25; paviors, \$1.25; masons, \$1.50 to \$1.35; set dressers, \$1.00 to \$0.85; paviors and masons' laborers, \$1.00 to \$0.85; ordinary laborers, \$1.10 to \$0.75; watchers, \$0.80.

MATERIAL.	PRICE.
Bessemer steel rails (per ton) .....	\$40. to \$35.
(And bent by corporation's workmen.)	
Cast steel points (per cwt.) .....	6.
Cast iron sleepers (per ton) .....	30. to \$25.
Wrought iron holding jaws (per cwt.) .....	3.50
Phosphor bronze bolts (per cwt.) .....	45.
Wrought iron nuts (per cwt.) .....	7.50
Portland cement (per ton) .....	10.00
Syenite sets (per ton) .....	7.00
Syenite sets, specials (per ton) .....	8.00
Coal tar pitch (per ton) .....	8.00
Cresote oil (per gallon) .....	.05 to .03.

At these prices no wonder the railway can be laid at the surprisingly low cost of \$7,395.90 per mile (single line).

It would be a great thing for the United States if this "Lyver" system could be laid down in its large cities; and its greatest expense would be its first cost.

W. S. GRAFF B.

**The Sargent Safety Rod Coupler.**

The accompanying cut represents a new and useful invention, in the shape of a coupling pin, for horse and cable cars. It is operated from the top of the dasher, and it is

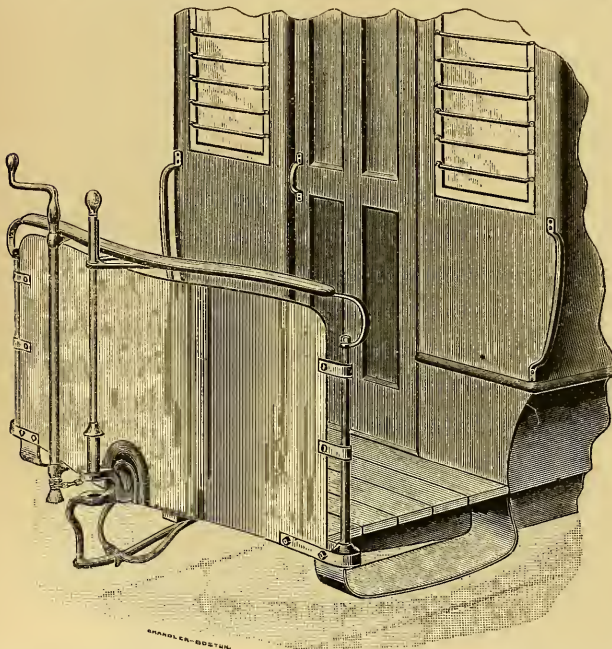

never out of position. Always being ready to drop into the bunter socket, without guidance, it does away with the old method of using a chain on the pin, thus saving the paint on the dashers, which of itself is quite an item in the course of a year. It also saves much time in attaching or detaching the pole to or from the car. It is equally useful for eveners, or swingle trees, and in the winter it does not freeze, as is the case with other kinds. It has been in use ten months; and experienced drivers speak highly of it.

A RECENT invention just patented by La Marcus A. Thompson, of Philadelphia, is an elevated gravity and cable railway constructed with descending and ascending planes, whereby a car may be carried by gravity or cable.

**Car Drivers' Views.**

"It makes a mighty sight of difference with a fellow to know his horses. By always driving the same team, the horses get so that they know what you are doing," said a sensible street-car driver of seven years' experience in a crowded thoroughfare, when questioned the other day. "Some men can not drive a team on the road at all unless they have a pole between the horses, and a pole is an awful nuisance in street-car driving, especially in cases of threatened accident. In the seven years that I have been driving, I have had many narrow escapes by being able to turn the horses quickly to one side or the other. You can't do that with a pole. I have never had anything happen to me beyond the smashing of a window. That happened once where a truckman was backing out with a load. The worst trouble we have is with the women who go out into the middle of the street and dodge back and forth. If they would stand still we would know just what to do with our car and our horses, but they make a dash across the street, then jump back, and then dash forward, and then make another dash back, so that in the uncertainty of what they are going to do, it is a wonder that we do not run over a woman every day. The general average of street-car drivers have their wits so much about them that if a person who happens to get in front of a car will only stand still, there is not the slightest danger of his being run over. Most of the men in large cities have come to understand this, and you rarely hear of an accident in which a man is run over by a street-car."

Another old hand at the reins related his front-platform experiences to a New York interviewer, on a Broadway car, saying, "I came on the Broadway cars from the University place line as soon as it was opened. I keep the same team the year round. I can do better work when I know my horses. I have not got my regular conductor on with me to-day or I could make better time. You see, it makes a mighty sight of difference with the driver when he knows the conductor's habits. My old conductor and I know each other. It makes no difference to me what conductor I have; I never look back into the car. I wait till I hear the bell. Some drivers are continually looking back into the car as if they were anxious for the conductor to start them up at the crossings. That makes the conductor nervous and mad, and he is not as likely to give the driver a fair show as if the driver just lets him alone and responds to the bell only."

An interesting addition to the advantages of electric cars over horse cars may possibly be the heating of the cars by electricity. An electric heater which has just been patented for use on surface cars consists of a plate of fire clay through which run the wires. When the current acts, this plate becomes sufficiently hot to heat the car. For surface cars of the larger size, the plates are twelve feet long, eight inches wide, and one inch thick. In experiments already made, two of these heaters have been used in one car, and it is found that in a half hour after the current began passing, the plates were giving out sufficient heat, and had attained a temperature of 180°. It is also found that the amount of current required for this purpose is almost insignificant, and would cost nothing as compared with the expense of stoves. The electric car, when complete, will therefore be run, heated, and lighted from the same current. As the use of electricity taken from storage batteries for lighting purposes it now becoming general on palace cars, and is soon to be introduced on the Pennsylvania Railroad on most of the trains, it may be possible that the same supply will be used for heating purposes. According to the experiments made the heater will remain at an effective temperature for nearly twenty minutes after the current has been withdrawn.



## American Cable Railway Construction.

BY AUGUSTINE W. WRIGHT.

PART I.—Continued from page 133.

Figure 18 is a view of the California Street Road, on the steep incline between Stockton and Powell streets. Figure 19 shows the ferry terminus.

## THE MARKET STREET CABLE ROAD.

The Market Street Cable Railroad is the most extensive one, and goes through the heart of the city from the water front to the suburbs. The equipment of the road is first-class in every respect, no expense having been spared in its construction. Traveling mainly on a street where there are some eight other lines of street cars, it immediately became the favorite, owing to the convenience and comfort of its

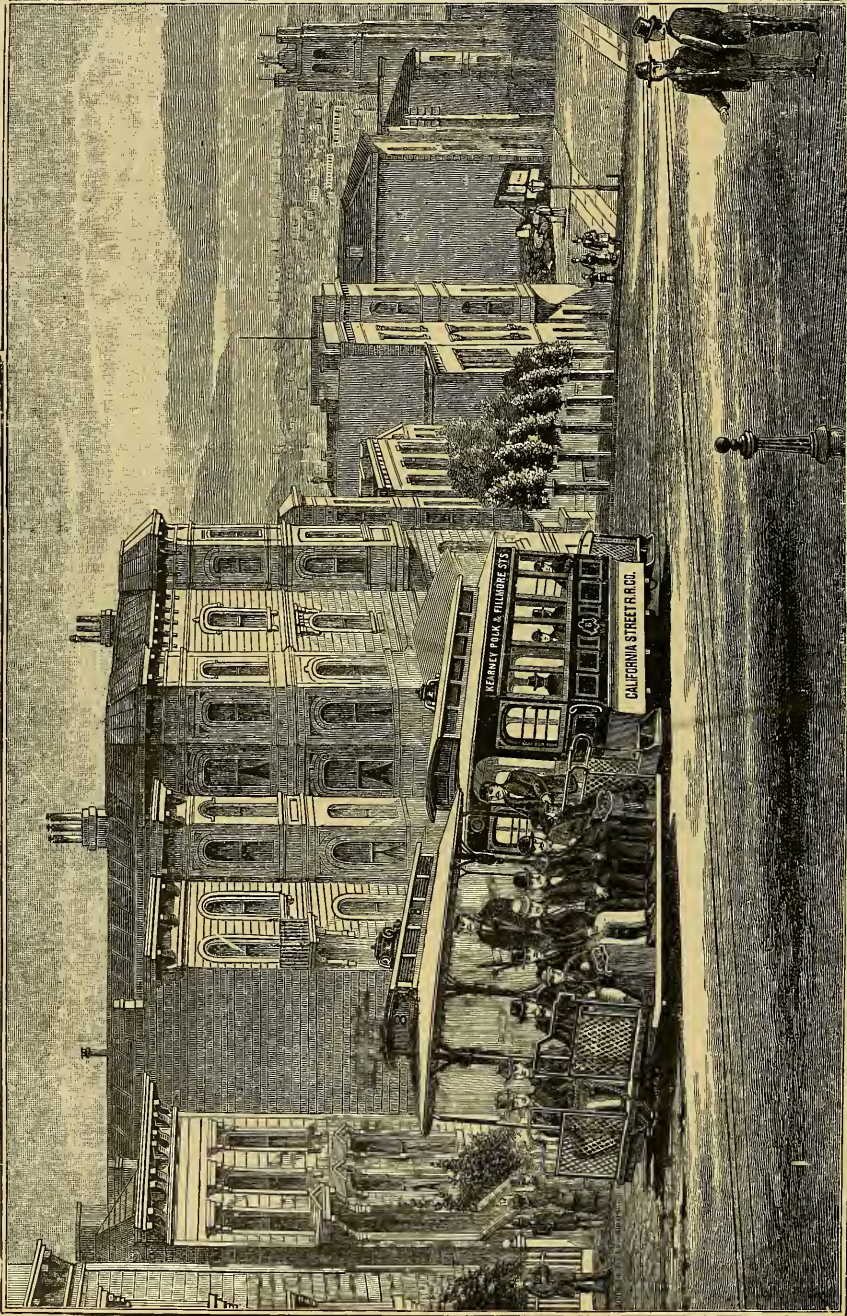

FIG. 18.—THE CALIFORNIA STREET CABLE RAILWAY, SAN FRANCISCO, CAL.



cars, the speed at which they travel, and the frequency at which they pass.

Shortly after the completion of this road we published a description of it, which we now reproduce as this description, with the engravings and details, will be valuable for reference to those interested in this branch of modern engineering progress. As they built the first of these roads here, their experience is useful to all others; and no doubt most of the roads built in the future will look to those in this city as examples for guidance.

The building of this road had the effect of enlivening, so to speak, a large tract of this city. For some years, south

towards the Mission and thereabouts, or even Market street to Tenth and Twelfth streets was detrimental to those portions of the city. The cable cars now go from the ferry to the end of Valencia Street in 34 minutes, and run frequently. All those portions of the city which the road or its branches tap have felt the good influence of rapid communication and have been extensively built up since the road was commenced.

THE ROAD AND ITS BRANCHES.

The main line of the road runs on the principal thoroughfare of San Francisco—Market Street. The streets north and south of this all open into it, and the traffic is larger

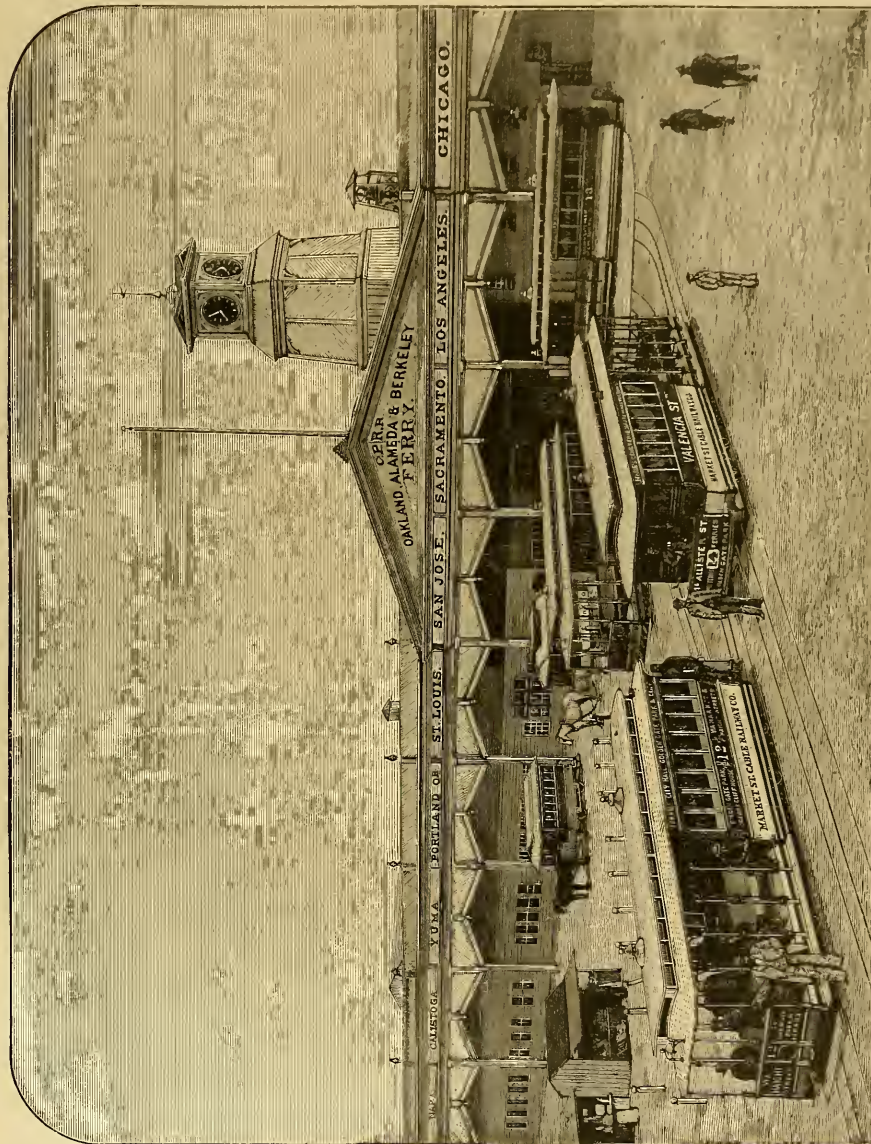

FIG. 19.—FERRY TERMINUS, SHOWING CARS OF MARKET STREET, AND TWO OTHER LINES, ARRIVING, TURNING AND DEPARTING.

of Market Street and out by Valencia, the city has been rather "slow," the northern and northwestern portions improving much more rapidly, and having improvements of better character. The length of time it took to get out

than on any other avenue in the city. Not only do the north and south streets, such as Kearny, Dupont and Stockton, and Second, Third and Fourth open into Market, but the streets north of it running across Kearny and Dupont,



such as O'Farrell, Sutter, Post, Geary, etc., also open into it. This latter line of streets run at an angle from Market. The lower ends of the cables of the Sutter and Geary street cable roads are at the junction of these respective streets and Market. The peculiar central position of Market Street, therefore, makes the road a highly important one. It was supposed by many that a cable railroad on that thoroughfare would be almost impracticable, owing to its crowded state at certain periods of the day. Many thought the cars would have to move so slowly that they would be unpopular. Experience has, however, proven these fears to have been unfounded. In fact, the line makes better time than any of the cable roads, the cable running about 8 miles an hour; and, including an average of 30 stops, the cars run from one end to the other at a rate of about  $7\frac{1}{2}$  miles an hour.

It has been found, too, that the speed at which the cars are run tends to make people more cautious than on slower roads. Moreover, the track is kept clear easily. Teamsters know that the cars run fast, and at the first sound of the gong clear the track, not taking time about it, as is apt to be the case with slower roads. People are not apt to try to run across in front of these cars, but seem rather to prefer letting them pass. The quick speed, therefore, has been advantageous to the road, and is very satisfactory to the public.

There are several branches to this road, transfers for which are given passengers without extra charge, the fare being 5 cents. At Fifth Street is a horse car branch one mile long, running south. At McAllister Street is a cable railroad branch, which runs to Golden Gate Park. There is a separate cable to Market Street, run by a separate engine, and the cars switch off from this to the Market Street cable at the junction of the two streets. This branch makes another complete line from Golden Gate Park to the ferry. The engine house of the line is at the further end of the road.

At Hayes Street there is a horse car branch to Hayes valley, through a populous neighborhood. The next branch to the right is that of Haight Street. Every other car on the main line switches off here to go out Haight Street to Golden Gate Park. At the end of the Haight Street line a road is built to run as far as the Pacific Ocean beach and Cliff House. This is run by steam dummies, and is a separate line from Haight Street, though connecting with it. The Haight Street branch is a very important one, and the city has been built up rapidly out in that direction. Opposite the main line engine house is the Market Street extension branch, soon to be run by an independent cable, provision having been made in the engine houses for the cable for this branch. It is one mile long. Baldwin locomotive dummies are now running the cars on this branch.

The grade on Market Street is  $3\frac{1}{2}$  feet in 100. The grade at Haight Street is about  $12\frac{1}{2}$  feet in 100 at the steepest place, and the steepest grade on McAllister Street is  $12\frac{1}{2}$  feet in 100. It is on such grades that the cable is incomparable.

#### THE ENGINE HOUSES.

The engine houses where the motive power of the cables of the Main line and Haight Street line is applied, is on the south side of Market Street at the junction of Valencia. At this point Valencia leaves Market by a curve to the southeast, and Haight Street branches off at an angle of about 35 degrees from Market to the northwest, some 500 feet before Valencia is reached. In the rear of the engine house are bunkers which hold 2,000 tons of coal, which may be dumped into them through chutes in the yard above. Heavy brick pillars and arches support the roof of this portion, which forms the floor of the yard above. Outside the coal bunkers is an artesian well which supplies the boilers with water. One of Dow's direct-acting deep-well pumps raises the water from this well, supplying first the heaters for the boilers, the surplus going to a tank above.

The main portion of the basement is covered with a heavy brick flooring and foundation to the boilers, engines, heaters, etc. The room is well lighted and ventilated. In the rear of the engines are the long pits and tracks for the stretching apparatus. At no distant day we will have a detailed description of the underground workings at the junction of Market and Valencia streets.

Outside, the most prominent feature of this building is the chimney, which forms an important landmark, and is next to the largest on the coast. The base is nine feet below the level of the fire-room floor, so that it is about 24 feet below the surface of the ground. The foundation is 30 feet square, battering in one inch to the course until it comes to  $16\frac{1}{2}$  feet square, where the flue enters. Then it goes up to the water-table, about 10 feet above the surface of the ground. For the rest of its height the chimney is in the form of an eight-cornered star. The inside is a circle seven feet six inches in diameter. The top of the stack is 175 feet above its foundation, or 166 feet above the fire-room floor. It was necessary to have this very high stack not only for good draft, but also to deliver the products of combustion high up out of the way. We give an engraving showing the exterior of the engine house. An engine house of similar design has since been constructed on the block bounded by McAllister, Lott and Fulton streets and Masonic avenue for operating the McAllister Street line. This same engine will be used shortly for operating the Hayes valley branch, which will soon be turned from a horse to a cable line.

#### THE ENGINES.

The power for the first-named lines is two pair of engines, with cylinders  $34 \times 48$  and  $24 \times 48$ , a large and small one being compounded to work in pairs. The expansion cylinder has a capacity of double the initial cylinder. They are compounded by direct connection between the bottoms of the large and small cylinders. There is no extra receiver, the pipe answering as the receiver. Only one pipe run at a time, the other pair being spare engines, to

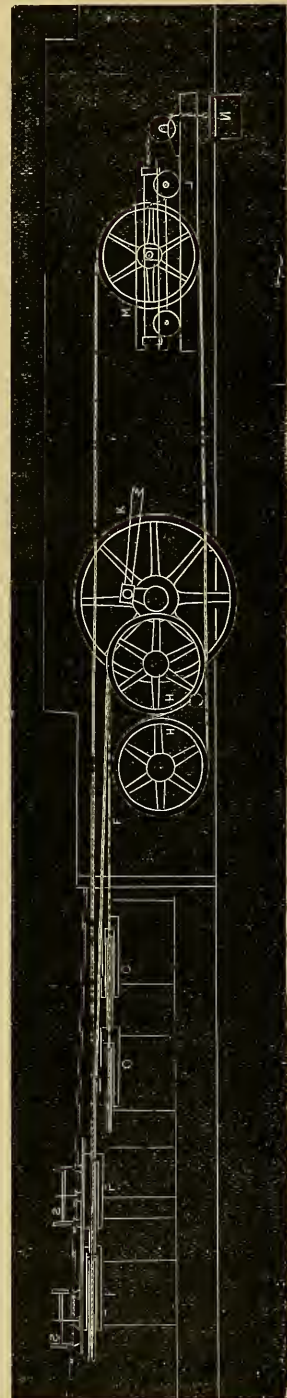

FIG. 20.—SECTION OF ANGLE SHEAVES, DRIVERS AND TENSION APPARATUS



use in case of breakage of the others. These engines have Scott pillow-blocks, and the O'Neil cut-off, with automatic governor. They were made by the Union Iron Works of this city. The engines are well made and are doing very satisfactory work, the cards showing great efficiency.

(To be continued.)

### Chas. J. Van Depoele, Electrician.

An ambitious young student, a graduate of one of our principal universities, flushed with the honor of having gained his *Artium Baccalaureus*, called at the editorial department of THE STREET RAILWAY GAZETTE, near the end of the month during which the sun enters the sign Leo, for the purpose of ascertaining the whys and the wherefores of the application of electricity to propel street cars. To gratify the longing of this enquirer after truth, we took him, by permission, to the works of the Van Depoele Electric Manufacturing Co., at Chicago. We were heartily welcomed by the company's secretary and treasurer, Mr. W. A. Stiles, who proceeded at once to speak of the grand success of the eight lines of electric railways in operation under the Van Depoele system, and of the company's flood of new contracts and numerous negotiations.

For the particular information we had come after, we were introduced to Mr. Van Depoele. He first showed us a 50 h.p. motor. "This is for a freight street railway at Ansonia, Conn.," said he, "and will, therefore, be required to propel heavy loads occasionally. For the same road there are also three 15 h.p. motors to propel three passenger cars, each car being capable of hauling one additional car. This is to be a first-class road for both passengers and freight."

"Now, what number of horses would be required to do the work which a 15 horse-power electric motor can perform?"

"Five heavy horses might do the same amount of work, *i. e.*, exert the same force as a motor of mechanical 15 h.p. That is five horses at a time. To keep at it a whole day, four sets of five horses would be required to do the work of one of these motors."

"Well, the average life of a heavy street car horse, if well cared for, is five years. How long will your motor last, Mr. Van Depoele?"

"Forever! At all events, if any particular part deteriorates, it can be renewed without any trouble, and at small cost. Any part can be duplicated readily, as every portion is made and fitted by machinery; and our motors may be kept in perfect order as easily as any first-class machinery. Everything is made strong enough to last a hundred years."

"Is not that providing too much for the future, and looking too far ahead? We know not what a day may bring forth; and even before the year 1900 arrives, electricity may be superseded by something still better."

"Oh, electricity is come to stay longer than that. And our method of applying it to propel street cars is permanent. There may be improvements in details, probably; but the system, as a whole, is complete and lasting."

"That is very good, certainly. Why, then, are so many street railway managers 'hanging fire' so to speak, and 'waiting for something to turn up?'"

Mr. Van Depoele replied smilingly: "Well, it is good for us that they are not all converted at once—else we could not supply them soon enough."

"Still, it is fair to presume you may discover further improvements to make?"

"Certainly; we have several patents now pending. We have over two hundred patents and applications in all, bearing on electric railways."

"You seem busy, too. How many men have you at work?"

"We employ over one hundred. Our premises are far too small. We are going to build new manufactories as soon as possible. In the mean time we are being helped out by the Featherstone people, who are now making 50 motors for us; and some of the generators they are constructing for us are 250 h.p. They have also on hand two 25 h.p. motors for Scranton, Pa., which are to be used to draw extra heavy trains."

"Of the working of your system at Scranton, we have

read much; and at Montgomery, Ala., you seem to be doing well."

"Very well, indeed. We are running 15 miles of road at Montgomery with 15 motors—12 are 10 h.p., and 3 are 15 h.p. The latter draw a train of three cars."

"What are the capabilities of the smaller ones?"

"A ten horse-power motor is used for one car, and this it can manage thoroughly up very steep grades. The working expenses are fully 50 per cent. cheaper than had been expected, at Montgomery. Ten cars take only 35 cwt. coal per day of eighteen hours, the price of which is \$2 per ton."

"In all you have eight electric railways in operation—aggregating over forty miles of track, and running sixty cars—according to report. What are the prospects of the immediate future?"

"Why, we have eight new contracts closed, and are negotiating with several others. Dr. Mercer was here on Saturday (July 30), and contracted for twenty cars, each to have a 12 h.p. motor, for seven miles of his electric railway at Omaha. One-half are to be ready for operation on October 1st; the remainder to follow as soon as possible. There will be from 15 to 20 miles of road ultimately, but the seven miles must be constructed right away."

"Eight lines finished and in successful operation, and eight more contracted for—that makes sixteen."

"The eight new roads will make a total length of about 88 miles—over double the length of the first eight—and will cost about \$250,000, as far as covered by our contracts. We could not wish the work to proceed faster. With everything new, there is always a great deal of unbelief. The Thomas class of disciples are very numerous. They won't believe until they see; and then their doubts cling to them tenaciously. They come around fast enough, however."

"Well, in our extensive correspondence with street railway companies, and as the GAZETTE 'pointers' plainly show, many are waiting—not in doubt exactly—but expecting some important advance to be made. There is a general expectation for something to turn up."

"I think it is useless to expect anything better. Electricity is now controlled and regulated better than steam. It isn't an uncertain power, and it is constant as well as lasting—you know what you have to depend on. But I think it is doubt more than indefinite expectancy that makes people hesitate. Do you know Mr. Kilgour?"

"John Kilgour, president of the Cincinnati Street Railway Co., we know well. Is he in love with your system?"

"He is likely to engage us to put electricity on four lines in Cincinnati; but—not yet! He will wait until he sees our system in operation at Dayton, Ohio. He has seen our new electric railway at Lima, O., (where we have four single cars, and one train of cars running), as well as our older and bigger lines which have been in successful operation a couple of years; and yet he will wait to see the working of our system at Dayton. Our Dayton line will differ from all the rest, however, in having an underground conductor for a part of the road (about two miles)."

"What is the expense of the underground conduit, as compared with the other?"

"With the overhead wire, it costs about \$1,000 per mile, while the underground conduit costs seven times as much."

"How soon will the electric road at Dayton be in operation?"

"The White Line Street Railway Co., of Dayton, Ohio, is now laying six miles of track, and has contracted for twelve cars to be running in October—ten cars to have a 12 h.p. motor on each, and two 15 h.p. motors to run trains of cars. In the evenings the cars will be lighted with electricity—that is done on all our cars."

"What about storage batteries for street car use?"

"A great deal of experimenting has been done with storage batteries. We spent a large amount of money in experiments with them and have quite a number of patents. We do not believe they will ever be a success for street railway work. Even if they were a success in propelling the cars, they would not be a success economically. The great disadvantages in the use of storage batteries are, in the first place, the immense weight required per horse power, which

has to be added to weight of cars and passengers, and which is especially objectionable where grades have to be overcome; and, in the second place, the batteries have to be replaced too often when doing heavy work, and would be liable to give out on the road when extra work would be required—as always happens in regular street car service; thirdly, there are too many conversions from the prime power to the motor, too much loss, too expensive. Fourth, the comparative short life of the batteries makes it cost too much; all of which drawbacks are avoided by a direct system of transmission—overhead or underground.”

Mr. Van Depoele's conversation was very interesting, as he took us over the manufactory. And he and his company are enthusiastically engaged, head and ears, in electric railways. They speak of what they have accomplished, as well as of what they are doing and what they are going to do. And, like a famous Roman, they know whereof they speak.

But our friend, the Bachelor of Arts, in turning over the leaves of his memory, and applying thereto the eye-glasses of his understanding, calculated himself none the wiser after being “through the mill.” He had seen the motors, and listened attentively to the electrician's explanations; but he was yet like a man trying to read before learning his alphabet. To understand the subject through and through, it is necessary to begin at the beginning, and proceed gradually. And, moreover, a master electrician must be specially inspired; and even to be a successful student, much of the same enlightenment is necessary, together with years of hard work.

### A New Electric Railway System.

The idea that something new is coming out has been “in the air” for some time. A pamphlet has come to hand which bears tokens of having been rushed through the press with so much urgency that the “Sun” proof reader had to “hurry up.” The language of the title page can not fail to be attractive to many readers of THE STREET RAILWAY GAZETTE. “The Ries Electric Railway System, comprising the latest and most economical methods of operating street railways electrically—entirely comprehensive in scope, novel in construction and design, and embodying in the highest degree the qualities of simplicity, safety, economy and reliability—the only practical system of electric railways that is thoroughly complete within itself and independent of every other electrical system at present in use.” And the text is in keeping with the title. The Ries electric railway brake was described and illustrated in last month's GAZETTE. We had been given to understand that the Baltimore electrician and engineer, Mr. Elias E. Ries, had some important invention, connected with electric railways, rapidly maturing. And already his book has arrived—containing a charming electric railway, as far as such a thing can be put in printed words.

Many clever inventions—going to revolutionize, etc., right away—have been admirably presented from time to time before, on paper, without ever coming to anything. That may be the fate of this “only practical system of electric railways that is thoroughly complete within itself.” But, on the other hand, it may come to stay and become a grand success. At all events, let us give this new aspirant for the favor of street railway companies a fair hearing. The inventor is not a crank. He is well known as a man of great experience and sound sense. And his electric railway system—whatever may become of it—is not the result of a midsummer night's dream. Let the pamphlet speak for itself:—

“The Ries electric railway system is the result of several years' original study, investigation and experiment, and is in many respects radically different from all other systems. It contains a number of decidedly new and novel features of great practical value that are not only entirely original and unlike anything heretofore produced, but serve to render this system the most economical, practical and efficient in existence.

“This system has been specially devised to meet the requirements of street railway traffic in large cities, but it is likewise applicable to the propulsion of cars or trains on

suburban, elevated, underground, and, to a certain extent, on trunk line railways.”

The line conductor and secondary battery methods may be combined in the Ries system, or either of these plans of obtaining propelling force may be used independently. There is a tone of charming convenience in this declaration. If it becomes in practice like what it sounds in this literary state, it may mark an epoch in street railway operations.

“One of the chief peculiarities of this system is that neither the line conductor or the secondary battery methods are entirely depended upon to furnish current to the motors, but a combination of both methods of supply is employed, this being carried out in such a manner that not only are new and highly important results obtained that are not possible with either system separately, but the best elements of both the secondary battery and line conductor systems are utilized without any of their individual disadvantages.

“Of the two methods just mentioned, the line conductor system of supply has very clearly the advantage in point of economy and efficiency over the secondary battery system, especially for city street railways on which the cars run under close headway and where the first cost of the conduit required for the supply conductors can be proportionately divided among a larger number of cars. On the other hand, the secondary battery system has the advantage (aside from the fact that no underground conduit or line conductors are needed), that each car is provided for a limited time with an independent source of power that permits of ready control and is not affected by interruptions in current to which the line conductors may be liable, and which does not restrict the car to any particular line of way. It is a fact, however, well known to all electricians, that the advantages of the secondary battery system as at present employed are far more than offset by the greatly increased outlay for running expenses and maintenance when compared to the direct supply conductor system, this being due first, to the necessity for providing and maintaining two complete sets of battery for each car, only one of which is at any time engaged in doing useful work; second, to the large amount of battery requisite for the necessary eight hours' supply usually provided in these systems to reduce the number of shifts; third, the great additional dead weight to be hauled per car, and consequently the larger amount of power needed at the charging station for operating the road; fourth, the loss of current due to conversion, amounting, in batteries of the most approved construction, from 20 to 25 per cent. of the total current generated; and fifth, the additional attendance required for handling the batteries and the extremely large cost of renewing the plates and maintaining the batteries in proper working condition.

“A properly constructed conduit, such as employed in the present system, and in which the supply conductors that extend along the line of way are in direct and constant communication with the dynamo-electric generators at the power station, while a little more expensive as to first cost, is by far more economical and efficient in operation, while the expense of maintenance is extremely small compared to that for the secondary battery system.

“In the operation of electrical railways, however, it is possible to obtain much more economical and efficient results, to say nothing of other desirable effects, that are not feasible with underground conduits alone. Furthermore, underground supply conductors are open to several slight objections that do not apply to secondary batteries, and it is with the object of securing these results and overcoming these objections that the combined line conductor and secondary battery system has been devised.

“This feature of the Ries system is employed in all cases where economy and reliability in operation is an object, and also in special cases where the cars are to be operated partly on non-electric branch lines or suburban extensions of the main line. It should be understood, however, that this system is not limited to the use of the “combination” method.

“In addition to the feature just referred to, the Ries Electric Railway System embraces a number of other appliances and methods, relating to the generation, transmission and distribution of electrical power for railway purposes, and



including special forms of underground conduits and other devices essential to the successful practical operation of electric street railways on a commercial basis. In this system of electrical railways the generating dynamos, motors and other appliances have been devised with special regard to the particular nature of the work to be performed, in order to gain the highest possible efficiency throughout the entire system, from the initial generation of the current to its final conversion into useful work on the driving axles of the motor cars. Every advantage has been taken to profit by the results of practical experiment made in this direction, and the system at present offered is believed to embody radical changes that will be found of the highest practical importance, and go very far toward solving the problem of cheap, safe and rapid transit."

In dealing more specifically with the Ries "combination," it is said: "The supply conductors, out and return, are carried in an underground conduit of special construction, and each car is provided with a single set of secondary battery of sufficient capacity to run the car continuously for two hours. This battery weighs less than one-fourth that ordinarily required for secondary battery cars, occupies no useful space, and is never removed from the car. It requires no change whatever in the body of the car for its reception, and the total amount of battery required for the road is less than one-eighth of that usually found necessary. Furthermore, as these batteries are only used as a source of reserve energy, and require no handling or shifting about, their life is greatly prolonged. These batteries are charged with current in one of several different ways, while the cars are in motion, and are automatically maintained at their standard strength without any personal attention whatever on the part of the motorman. According to one of these methods, the battery cells on each car are charged directly from the supply conductors in the underground conduit at such times when the motor is not drawing its full supply of current, or when the car is stopping to take on or let off passengers. In this way enough current is stored in the battery while the car is running to normally maintain an independent reserve source of energy on each car sufficient, as before stated, for a two hours' supply. It should be understood here that when the battery is not drawn upon during a trip no recharging of the battery cells from the line conductors is necessary, this recharging process taking place only after the charge in the secondary battery has become partially depleted by actual use. The benefits derived from this reserve energy are very numerous and valuable, inasmuch as it secures all the advantages of the direct supply system in point of efficiency and economy, while embracing at the same time all the beneficial results due to the independent control and flexibility of current characteristic of the secondary battery.

\* \* \* \* \*

"Another and different adaptation of the secondary battery principle to electric railways in which the motor-cars normally derive current from supply conductors, is embraced in The Ries Electric Railway System. This method is particularly adapted for railways having a number of grades, and in such cases is of the utmost importance and value from an economical standpoint. In this instance the secondary battery carried by each motor-car is not charged with current from the supply conductors of the railway, but the electro-dynamic motor is automatically changed into a generator whenever the car or train is coming to a stop and when descending a grade, and the current thus generated under the influence of the surplus energy or momentum of the car or train is fed into the secondary battery, where it is stored in the form of chemical energy for the time being, ready to be given out as useful work whenever required. This stored energy is automatically given back to the motor when the car is about to start or is ascending a grade, and serves to reinforce the line current and co-operate with it in overcoming the inertia of the car and in propelling it up hill.

"There is, however, another advantage connected with this method of operating the cars or trains, and this arises from the fact that by converting the motor into a generator the motion of the car or train is retarded, this retardation

being directly proportional to the amount of current that the motor is generating. This fact is taken advantage of in regulating the speed of the cars on descending grades and for bringing the car or train to a stop without the use of special breaking devices other than that furnished by the revolving armature of the motor itself. By this means a train of cars under full headway can be brought to a standstill more rapidly than by the most approved form of air brake, and this without the wear and tear of brake shoes and wheel tires, and with the expenditure of no power except that of the moving train itself."

Special advantages are also claimed for the Ries Double Armature Generator, which has been "designed expressly to adopt the current generated to the special requirements of electric railway work. This machine is constructed on entirely new principles and is different from anything heretofore produced. It is provided with two armatures and has interior as well as exterior field magnets, whereby an intense magnetic saturation is obtained with very little expenditure of current, and the entire current productive capacity of the armature coils utilized to the greatest possible extent. The lines of magnetic force are concentrated within the machine in such a manner as to produce the greatest inductive effect upon the armature coils, and yet are so entirely self-contained that a watch brought into close proximity to the machine will not be affected or injured by them."

From what is said on "special methods of transmission," the Ries plan may, without impropriety, be termed

THE LOW-PRESSURE SYSTEM.

For the electro-motive force is maintained at 300 volts, which "is found to be adequate for all ordinary installations." But for long lines of railway, "a special system of transmission and distribution is employed, the details of which can not as yet be made public."

When this invention has been more fully developed we will endeavor to find space for further descriptions. It may be added here that "Mr. Ries has devised an ingenious and extremely simple method of connection," between the motor and driving axles of car, "which not only dispenses with all belts, ropes, sprocket wheels, chains, connecting rods and worm gear, but affords other advantages of great importance. In this arrangement the motor is absolutely independent from the car body, it being directly supported within a light frame that bridges the driving axles. The armature shaft extends in a longitudinal direction and is directly connected with a driving gear on each axle, in such a manner that when current is admitted to the motor both axles will be revolved by it and the tractive force of all the wheels of the car thereby obtained. The connection between the armature shaft and driving axles is such that a certain amount of flexibility is maintained between them, so that the motor and gears are relieved from any strain.

\* \* \*

"Over each axle is slipped a coil of wire, these coils being connected in a derived circuit from the secondary battery, or supply conductors, whenever desired, by means of a switch under the motorman's control. When the circuit is closed through these coils the car axles and wheels instantly become powerfully magnetized, in such a direction with respect to each other that that portion of the track rails lying between them convey lines of force and complete the magnetic circuit. Each wheel thus becomes a pole of an electro-magnet whose circuit is completed through the track rails and axles, and is now found to adhere very strongly to the track and to offer an extremely large resistance to any slipping or skidding tendency, while its rolling motion is not appreciably affected, probably because of the presentation to the rail of a continuously new point of contact of the same polarity. The amount of current requisite for energizing this movable circuit is extremely small, and is insignificant when compared to the results obtained, while its magnetizing effect upon the ordinary iron axles and track rails is only effective while the circuit remains closed through the coils. In winter the track is cleared of snow by means of an electrically-propelled snow plow of special construction, and each car is provided with a fixed or rotary brush for cleaning the track rails sufficiently to enable the wheels to make good contact therewith, in order that the circuit through the wheels may be complete."

# The Street Railway Gazette.

Annual Subscription (Including Postage).	Per Copy.
United States, Canada .....	\$2.00 .....
Great Britain, Ireland, India, Australia .....	20c. ....
Germany .....	10s. ....
France, Belgium, Switzerland .....	9mk. 75 pf. ....
Spain .....	1fr. 95c. ....
Austria, Holland .....	11ps. 95c. ....
Italy .....	5fr. 74c. ....
Venezuela .....	12 lire. ....
Mexico .....	12 boliv. ....
	\$2.96 .....

Ann. Subs. in Argentine Republic, 2½ peso; Brazil, 4 milreis; Turkey, 54 piasters

Registered Cable Address—TRAM, CHICAGO.

**PUBLISHERS:**

**THE WRIGHT-MONROE COMPANY.**

Augustine W. Wright, President.  
 E. V. Cavell, Secretary.  
 S. L. K. Monroe, Treasurer.

**GENERAL OFFICES:**

CHICAGO, NEW YORK, BOSTON.

**CHICAGO:**

9 LAKESIDE BUILDING.

P. G. Monroe, General Manager.  
 William Hughes, Editor.  
 Edward J. Lawless, Associate Editor.

**NEW YORK:**

181 BROADWAY.

Henry C. Lockwood, Resident Editor and Manager.

**BOSTON:**

19 TREMONT ROW.

T. P. Pemberton, Resident Editor and Manager.

**EUROPEAN OFFICE:**

LONDON: W. S. G. Baker, Jr., (care Brown, Shipley & Co.), Res. Mgr.

**BRANCH OFFICES:**

ATLANTA, Ga.: Chamber of Commerce Bldg., Wm. Minnigerode, Mgr.  
 SAN FRANCISCO, Cal.: 1222 Bush St.,—G. W. Fairchild, Manager.

**CANADIAN AGENCY:**

TORONTO: 53 Magill Street,—Thomas Henry, Manager.

OUR Street Railway Directory of the World is issued as a Supplement to the present number of the GAZETTE. Part first contains a list of street railway companies, and their leading officials, as far as definitely known, together with length and gauges of tracks, kinds of rails, numbers of cars and horses or mules, and sizes of electric motors, as well as horse-power and cable engines or steam motors where used. The population of each city (at taking of the last census) may afford some idea of the constituencies of the companies catering to their riding propensities, and these being arranged in States, etc., show how the ground lays as to street railways. And by means of abbreviations—fully explained at the head of the Official Directory—extensive information is compressed into small space; *multum in parvo*.

As we go to press we are informed that President Powers, with a majority of the directors of the Boston Consolidated St. Ry. Co., have followed the lead of the Metropolitan R. R. Co., in transferring their stock to the American Loan and Trust Co., in exchange for West End Stock. The Metropolitan proceedings therein are fully reported on page 19 of our Directory Supplement.

THE street railways of Chicago developed a new state of existence and management on the 6th inst. The original South Side system remains in *statu quo*. But Mr. Charles T. Yerkes, and the capitalists at back of him, have purchased the West Side street railways—"wholesale." And hereafter all the surface street railways of this great city of the West will be managed by two veteran superintendents—Presidents Holmes and Yerkes. Details of "Yerkes' Latest Deal" appear in our "pointers."

"We are investigating the electric motive power," says Mr. Stephen Adams, president of the Lynchburg St. Ry. Co., Lynchburgh, Virginia. And from our "Pointers," in this and previous issues, it may be seen that some "would like full information on electric motors," while others are "waiting for something to turn up."

MR. HENRY SCHWEITER, president of the Wichita Rapid Transit Co., Kansas, has gone east to purchase new cars and steam motors. The line is in good condition and the business has been much better than anticipated. The company is well pleased with the outlook and intend to serve the public as well as possible.

FINDLAY, Ohio, has been set a-booming by natural gas. And it must have proper street car facilities. A Findlay correspondent informs us that they are going to have three different car lines built at once. "Those who wish to supply rails, ties, cars, and all that is necessary for a street railway, should address Geo. B. Kerper, Findlay, Ohio," says he. Having read the communication so far, we wondered if this is the veritable Geo. B. Kerper that we have long and favorably-known; and the conclusion of the correspondence lights up the surmise. "This gentleman is from Cincinnati," it is said, "and is in the real estate business here. He has received a franchise to build a street railway in the main part of the city, and will build at once."

A NEW conductor is readily recognized on a street car. A conductor of many years' experience, in the course of an argument in favor of encouraging "old hands," humorously told his superintendent, "It is the easiest of easy things to tell when there is a new conductor aboard of a street car. In the first place his peculiar awkwardness is a most positive assurance. There are several other ways that reveal him. One is that he is very apt to ask you for your fare the second time; another, that he is too busily engaged in watching his passengers to look smilingly on the ladies, and he never attempts to flirt until he has been on the road a couple of months. A new street car conductor never wears a button hole bouquet under any circumstances."

"THEY wait, with longing eyes, further developments," Dryden may have said, had he flourished in this hot summer of progress, 1887, and perceived the attitude of longing expectation in which many street railway managers are now standing. The Parsons Street Railway Co., of Parsons, Kansas, for instance, are actually delaying the construction of their street railway, although they have purchased rails, ties, and stringers—everything is ready; and still they are waiting for something; but what it is they do not exactly know. The fact is expectation is ripe for the advent of some extraordinary improvement in the means of propelling street cars.

THE finest street cars running in the United States (and therefore in the world) are to be seen on a line in New York City, it is claimed. And, barring that one road, Clay Centre, Kansas, has the courage to declare that its couple of Pullman cars, which have been running there since July 4th, are the handsomest. On their arrival the local organ announced that "the long-expected street cars came Saturday, and to the chagrin of the croakers they are just a little bit more elegant than the average citizen of this town ever saw. The actual cost of their manufacture was \$1,278 each. The cars seem to us larger than the average, the inside finish being of mahogany. The lamps and fare boxes are as handsome as can be, and of the latest improvement. Instead of the old method of running the rope connecting with the bell down the centre, so that the passenger is compelled to rise from his seat to give the signal to stop, straps run along either side of the car in convenient reach for the passenger, and he can jingle the signal with ease. Taken altogether—track, cars, equipment of every kind—Clay Centre can feel proud of her street car line. They are now making regular trips to the end of the road."



EACH alderman in Kansas City received a circular—in support of the ordinance for another gigantic street railway in that city, particulars of which appear in another part of this GAZETTE—in which it is declared that there is no city in the Union where as many fortunes are being made in real estate and business as in Kansas City, and that this is largely due to the courageous men who invest their capital and are developing the streets and avenues to suburban territory by means of quick transit. "Each railroad encourages other roads to build, and every franchise should be granted free, with no incumbrances, and not drive out foreign capital which is seeking investment here. This foreign capital has made our city, and will make it the greatest inland city in the United States, and 90 per cent. of its success is due to the development by quick transit and foreign capital, and we, as a body, should do everything to encourage that capital to come here and develop our city."

A LEAF in the life of Adam Forepaugh, the rich showman, is interesting to purchasers of street railway horses. Mr. Forepaugh began life as a butcher boy in Philadelphia at \$4 per month and his board. Then he worked west and reached Cincinnati, where he remained in the employ of John Butcher, well named for a butcher, receiving \$50 for the first month, and \$100 a month until the expiration of a year and a half. He didn't find anything in the Queen City to suit him, and he walked all the way to Dayton, Ohio, to look for a job. After a time Forepaugh returned to Philadelphia. He had saved some money, began as a drover in a small way, and gradually increased his business. When the war broke out Forepaugh took advantage of the demand for horses and bought heavily from farmers. He also got the contract to furnish animals for the horse-car railways in large cities. Indeed, the demand was larger than the supply. He had his agents buy the old worn-out street-car horses, send them to an island in the Schuylkill, jockey them up and resell them to the same companies for new horses.

"THERE'S millions in it," it is claimed for an invention of Monsieur Shipe, owner of the Abilene Street Railway, and by virtue of which he claims a right to the title of "Colonel Sellers No. 2." Mr. Shipe, however, may be suspected of cruelty to animals (if mules may be honored by that designation); for, if the report we have received be true, he has invented a device, simple and effective, which consists of an iron rod fastened securely to the car, and running out and over the mules. At the end of the car is a pulley and tackle. "The tackle is fastened to the animals, run through the pulley, and tied to the brake. When the mules lay back their ears, show their teeth and evince other signs of trying to outrun the car, all the driver has to do is to set the brake, which stops the car, and at the same time winds up the tackle, elevating the mules about two feet from the ground. They can then paw the air until their enthusiasm abates, when they may be lowered, and allowed to step off on schedule time."

LEGAL difficulties have arisen in several instances through the carelessness of city officials in granting street railway franchises. Des Moines, Iowa, is a recent case in point. The city council passed an ordinance in 1868, granting to the street railway company, who presented the ordinance, "the exclusive right" to run street cars in the city for a term of thirty years, and the council therein undertook not to grant to or confer upon any person or corporation "any privileges which will impair or destroy the rights and privileges herein granted to said company—until the expiration of said term" (in 1898). That franchise was sold, and the assignees, The Des Moines St. Ry. Co., when opposed by a rival street railway company, to whom also a franchise was granted to build and operate a street railway in the city, insisted upon the exclusive rights which they had purchased. The case has gone the rounds of the courts; and the law maintains the claim of the Des Moines St. Ry. Company.

## The Sprague Electric Motors.

Repeated mention of the East Boston electric freight railway has been made in the GAZETTE. An electric contemporary makes renewed reference thereto, saying: "The ease and slight expense at which an electric railroad can be operated in large works already provided with a dynamo for electric lighting is well shown in the venture recently carried out by the East Boston Sugar Refinery, at East Boston. This refinery, which is the largest in New England, is situated about 1,300 feet from the docks where the raw sugar is unloaded from the ships. Formerly the hogsheads and bags were loaded on a railroad truck drawn by horses, the work being such as to tax the animals very severely and necessitating frequent changes.

As the refinery is provided with a 150-light Edison plant, it was determined to put in an electric railroad, and the installation was undertaken by the Sprague Electric Railway and Motor Company of New York.

The rolling stock consists of two flat cars, one of which carries the motor of 15 h. p. at its forward end, together with a raised platform, upon which are placed the regulating and reversing switches. The cars are capable of taking a load of 12 hogsheads, equivalent to 30,000 lbs. The current is taken from the lighting dynamo and led to the motor from an overhead wire and trolley, the track being used on the return.

With the electric railroad the work of transferring can be done in one-fourth the time formerly required with horses; and although ships are constantly unloading at the docks the limiting capacity of the railroad to handle the work has not yet been reached.

The motor operates without noise, and although the track is always in bad condition, being invariably covered with sugar and molasses, no difficulty in operation has yet been experienced. Another interesting feature is the fact that thus far no appreciable increase in coal consumption, due to the operation of the electric railroad in connection with the lights, has been noticed.

The Sprague electric motors for newspaper printing presses, and for driving manufacturing and other machinery, are gaining great favor. The Detroit *Daily Tribune* was the ninth important paper to use the Sprague motor to run its printing presses, which they began to do on June 19; and it continues to give the greatest satisfaction. The *Tribune* says: "The motor used in the present instance is of ten-horse power, and readily performs the work that has heretofore been accomplished by an engine of double the horse power. The motor occupies but a few feet of space and can be tucked away in a corner where it will be least in the way. The motor can readily be started and checked, a simple twist of a lever performing the work. During the hot weather the press room is not rendered oppressive and uncomfortable by the presence of artificial heat. The motion is very smooth and uniform, and the work performed is satisfactory in every respect.

Another paper says: "We consider the Sprague motor first-class in all respects; whether we run one or more presses at a time, whether all are put in operation or shut down at the same time it matters not, it has no effect on the motor.

Among their more recent contracts for electric street railways we notice that the Sprague motors are to be placed on the Union Passenger Ry. Co.'s track, now in course of construction, at Richmond, Va. The power will be transmitted through overhead wires.

## An Excellent Picnic.

The Adams & Westlake Company, of 110 Ontario st., Chicago (and 115 Broadway, New York), whose street car trimmings are well and favorably known, held their eighth annual picnic at Willow Springs, near Chicago, Aug. 6th. There were from 400 to 500 employees and friends present. There were base ball, dancing, races, and other popular games; and a "good time" was thoroughly enjoyed. Dinner was partaken of from 12 to 1:30 o'clock; after which various valuable prizes were distributed to the victorious contestants

in Tug of War No. 1 (silver tea set), No. 2 (silver tea set); throwing quoits (1st prize, silk umbrella, 2nd prize, walking stick). Scarf pins, cuff buttons, silk handkerchiefs, pocket-books, opera glasses, toilet sets, suspenders, &c., were distributed, all of which inspired the winners and spectators with gladness.

### Street Railway Employees' Association.

The Street Car Drivers' and Conductors' Association of the United States met in Buffalo, Aug. 1st. They held their meeting in Metropolitan Hall, thirty-five delegates being present, and it was agreed to organize a national association. Henry G. Taylor, of Philadelphia, was chosen Chairman, and Mortimer O'Connor, of New York, Secretary. This meeting (which was continued next day) was the result of an informal conference held at Philadelphia three months ago. The matter of a national organization was then talked over and invitations were sent out throughout the country to meet in Buffalo. The American Street Railway Association has been considering the question of properly governing their employees; now the latter may try their hand at governing themselves. Unfortunately, their proceedings were secret.

### Construction, Equipment and Maintenance of American Street Railways.

BY AUGUSTINE W. WRIGHT.

(Continued from page 95.)

#### RULES AND REGULATIONS

FOR THE GOVERNMENT OF THE CONDUCTORS AND DRIVERS OF THE NORTH CHICAGO STREET RAILROAD CO.

(Adopted August 1, 1886.)

#### DUTIES OF THE CONDUCTOR.

1. He is to be cleanly in his personal appearance, make use of no profane or improper language, and is to abstain from smoking, from the use of intoxicating drinks, and all ungentlemanly conduct or unnecessary conversation when on duty or on the company's premises. He must not visit any saloon while on duty.

2. His position when on duty, and not collecting fares or seating passengers, will be on the rear platform. This position will the better enable him to keep a vigilant look out for passengers in the opposite direction from that in which the car is moving, on all corners and cross streets. He will announce the names of principal streets as they are approached.

3. He will endeavor, as much as possible, to be on the rear platform when the car is passing street corners, especially those where he is likely to receive passengers, and never to go inside of the car to collect fares as the car approaches a prominent cross street, but immediately after the car has passed it. The car should be gently slackened as it approaches prominent cross streets, to avoid collisions, and the better to enable the driver and conductor to see passengers upon them.

4. He is to stop the car in taking up and letting out passengers at the further crosswalk in going either way. He will endeavor to be on the rear platform, in all cases, when receiving or landing passengers, and not start his car until they are fairly received or landed; nor shall he allow elderly or infirm persons, ladies or children, to enter or leave the car while it is in motion, to get off or on the front platform. He will also, when passengers are getting off from the car, look and see that no car or team is approaching by which they might receive injury.

5. It is his special duty to provide seats for passengers as far as practicable, especially for ladies; and passengers must not be allowed to stand upon the rear platform or steps when there are seats or standing room inside the car, as they obstruct the passage of those who wish to enter or leave the car. The conductor should politely ask them to take seats or stand inside of the car.

6. He is to strike the bell to stop the car whenever any passenger makes it known that they wish to get off, notwith-

standing they say to the contrary. He is to render all needful assistance to passengers having children, parcels, etc., and especially to ladies and elderly persons. He will not allow any drunken, filthy or indecent person in or upon the car, nor shall he permit any passenger to use any profane or obscene language, or be guilty of disorderly conduct; such persons should be ejected from the car, using no more force than is necessary. On no account, however, is a passenger to be ejected while the car is in motion. In an ordinary case, or for a passenger refusing to pay fare, he is to call upon the nearest police officer. He is to be polite and courteous to all passengers, under all circumstances. He is to be patient, and answer any reasonable inquiry in reference to the road or company.

7. ACCIDENTS.—He will use the utmost care and caution to prevent accident of every kind to persons and property of the company. If any accident occurs, however slight, to persons or property, or to the property of the company, he must report the same as soon as possible to the superintendent or his assistant; also at the receiver's office for record; giving all the particulars and details, and, as far as he is able, obtain the names and addresses of all witnesses to the accident. If persons are injured, however slightly, he must obtain their names and addresses in full, and render all assistance in his power.

8. He is to obey the driver's call—a tap of the bell—to collect fare from passengers on the front platform immediately, and pass on the outside of the car when it is crowded. He will render all needful assistance to the driver, which will be called for by a tap of the bell, when it may be necessary to hold the horses, or detach them from the car, and he is always to take the horses by the head when they are to be changed from one end of the car to the other.

9. He will not allow barrels, boxes, lumber, iron, or merchandise of a bulky nature to be put on the car; neither large dogs, nor baskets or bundles of meat, inside the car; neither will he allow cards or showbills upon the cars without the permission of the superintendent or his assistant.

10. He is not to leave his car until he arrives at the end of his line, without permission of the superintendent or his assistant, nor to sit in his car when it is in motion, read the papers or any other matter that will interfere with the discharge of his duties.

11. He will report all defects in the road, cars or horses, or any excavations at the side of the track, to the superintendent, or at the receiver's office.

12. He must wear his badge at all times, when on duty, so that the number can be plainly seen by any one who may wish to know it.

13. He must be at the car house where the car is kept that he is to run, five minutes before the starting time. He must start promptly from the terminus of his route on card time, always keeping his watch exact with the clock at the receiving office.

14. All conductors, when appointed, are to serve as extras, in number according to their turn and time of appointment, as follows: When a regular conductor is discharged, No. 1 extra is entitled to his car, and the remaining extras are provided in their regular order. Should any conductor not be on hand as required by Rule No. 13, he will be placed at the bottom of the extra list, and extra No. 1, if in attendance, will be entitled to the car; if extra No. 1 is not there, the next extra who shall report himself is to take the car, and extra No. 1 is to be placed at the bottom of the list. He is to assist in taking his car from the car house in the morning and putting it up at night.

15. He must be in full uniform while on duty. He must call out streets going south from Chicago avenue and going north from Kinzie street.

16. He will obey the directions of the assistant superintendent concerning his duties at the car house.

17. When wishing to report for duty, will report to assistant superintendent before five o'clock p. m.

18. He must stop his car at the farther crossing of any street, and in the middle of long blocks where sign is placed, for any passenger who wishes to enter or leave the car.

*To be continued.*



### Elevated Railway Decisions.

The Court of Appeals of the State of New York has decided, at last, all the questions involved in the contest over the relative rights of the elevated railway companies and the owners of adjoining real estate. The decision is adverse to the roads. Property-owners will henceforth conduct their actions upon the theory that the only remaining question to be decided is one of damages. The lower courts had handed down varied and conflicting opinions. In the Story case the title to his property had been derived from the city under covenants protecting the street in front of his premises from any other use than that of a "public street," and the counsel for the roads contended that property obtained other than by a deed from the city would not come within the principles determined in that case. The recently decided case, however, has effectually disposed of that claim. "We are of opinion," says the court, "that no legal difference exists, with reference to the interest acquired by abutting owners on a public street, between that afforded by a title conferred under such a deed as Story had, or that acquired through a series of mesne conveyances from the original owner, whose property was taken by proceedings *in invitum* instituted by the municipality under a public statute to acquire land for street purposes, which provided that the land thus taken should be held in trust; nevertheless, that the same be appropriated and kept open for or as a part of a public street, etc., forever, in like manner as the said public streets, etc., in said city are and of right ought to be." Nearly all titles held along the elevated roads come within the lines of either one of these two cases. It would seem now, in the face of this decision, that those who are suing the roads will only be compelled to collect evidence showing the character of their titles and to establish the amount of damages they have sustained. This decision is not nearly as great a disaster to the elevated roads as it would at first seem, for the reason that these roads now have an immense income and are able to pay damages. If the companies had first had the damages assessed before proceeding to construct, possibly the roads would not then have been built. Then again the damages will be light in many places—the routes the tracks are in broad streets and business along the roads has been increased. These actions have been conducted with great ability on both sides, and the decision arrived at will probably be followed in other American cities.

### Pardy's Pneumatic Street Railway.

Mr. George Pardy, San Francisco, submitted a description of his "low pressure system" to the Street Railway Convention at Cincinnati last fall. It consists in frequently supplying an ordinary motor car with re-charges of low pressure compressed air from a pipe running from end to end of the line, by means of a flexible nozzle used by the driver standing on the platform, to tap the pipe at valved outlets placed anywhere along the route, generally at street corners. The re-charging occupies no more than the time necessarily devoted to taking on and putting down passengers. The economy of the system arises from the facts following: 1st. The service is performed with light rolling stock, requiring only a minimum effort to move it. 2d. The low air pressure gives a much larger percentage of useful effect than the high pressure heretofore used. 3d. There is no more power expended in operating the system than is actually required to move the cars and passengers. The first cost, probably the most important item, is difficult to compare with other systems in a general way, varying according to the conditions of each case, but it will be less than any known mechanical means of propulsion. It was estimated in a special case, by a careful engineer, Mr. W. H. Milliken, that the cost of this system would be \$105,000 as against \$450,000 for a cable system.

This system ceases to compete with animal haulage when less than say forty animals do the work, and with cables when the grades are long and steep. It should not be adopted on grades exceeding eight per cent rise and continuing over 1,000 feet, though it will do well on routes generally comparatively level, but having short, intermittent steep grades, a special provision being made to overcome

them. Tests of the system have been made, the capacity for mounting grades and making speed found very satisfactory. The time necessary to refill the storage tanks on the motors was found to be inconsiderable, and the facility with which the engine can be handled was thoroughly proven, nothing being left to desire in this respect. At first a noise from the exhaust was noticeable, but a simple remedy obviated all difficulty. The daily expense of running a plant supplying this motive power for, say, thirty cars, was estimated from the data obtained by these tests and found to be less than two dollars per day per car carrying 32 passengers.

"We have not yet succeeded in getting the system into practice," the owners of the system say, "because railway managers are loth to be pioneers in adopting our plans. We have offered, however, to take the risk of failure where we can get assurance of acceptance in case of success. So far this assurance has not been given us. We have been asked to build an extensive plant, not only at our own risk of failure, but at a still greater risk of acceptance even when completely successful. This has temporarily delayed, but not discouraged us. We have faith in our project, believing it will fill the severe requirements of crowded metropolitan streets, as well as the lighter service of country towns and suburban roadways. It is particularly adapted to consolidated systems; entire cities can be operated by one plant, and it is, of all systems, the most perfectly secured from breakdowns, saving that individual motors may fall out of service, but an operating line need never be disabled."

The motive power of Mr. Pardy's pneumatic system is one familiar to engineers; it is simple and not difficult to comprehend. "Its economy, both in first cost and running expenses, will not be doubted, and experts ought to be able to calculate upon every point involved with perfect accuracy, without the assistance or argument of the promoters." And in conclusion the promoters of this plan truly observe that no system will be accepted in general practice, which has not first been tested, criticised, practically developed and finally survived as the fittest. Then follow a number of indorsements by practical men, some of them being eyewitnesses of the trials that have been made of this low pressure air system as a motive power for street railways.

### Cheap Cable Roads.

Under this caption the *Mining and Scientific Press* (San Francisco) makes some statements which are inaccurate. It says: "While the people in the East recognize the utility and general good features of the San Francisco cable roads, they say they are too expensive to build. As a consequence, they have tried to build on the cheapest plan they could, and made a number of failures. The latest failure is that of the Park Avenue cable line, Brooklyn, N. Y. It was about a mile and a quarter long, and was built last winter. The cable feature has been given up and the bobtail cars put on the road instead of the handsome cable cars. This failure will be laid to the cable system, of course, whereas it was only a sort of mongrel cable, built in a cheap way, on a previous experience here entirely ignored. It had a rope-ladder cable—that is, two parallel ropes with cast links or bars between them. A sprocket wheel was placed on the dummy, this wheel being formed like a saw-plate and projecting through the slot, so the offsets would pass between the links or bars of the robe. When the car stopped the wheel revolved, and to start the car it was clamped and its rotation prevented, the car being thus carried along the track.

"This plan is not new and not practical. It is much like the Rasmussen-McNeal system, which was tried on West Lake street, Chicago, from Garfield Park to Fourth street. That road was built in 1886, but had to be given up as a failure. The Rasmussen system had only one rope, with bars on the side, with which a sprocket wheel engaged. This sprocket wheel is patented by Lafayette Foster. The ropes used with these systems are heavy and wear out quickly. The rope on the Brooklyn road wore out in three months. Double the power was required to drive it over what is used on our cable system in this city. It looks well enough in theory, but practically the idea is a failure. They thought they would have a small channel or tube for this

system, as there would be no deep projecting grip, and thus save expense of construction. But the tubes kept filling up, the rope wore out quickly, too much power was consumed, and the whole thing was a failure. The San Francisco systems of cable roads are the best in the world. They originated and were perfected here. They are long past the experimental stage and work steadily and well, serving every requirement. When people elsewhere want cable roads they should come here, get their plans, pay the patent royalties and build properly. If they must experiment, they should at least try and find out what has been done before in the same direction."

As to the Brooklyn cable line, the cause of its discontinuance is stated in our "pointers." The Rassmussen cable line, at Chicago, was only a short experimental one—temporarily placed at the extreme end of Lake street road of the Chicago W. Div. Ry. Co. It never was used for regular service. And, after serving its purpose, was abandoned. The GAZETTE does not advocate the Rassmussen, or any other system, in particular. But we wish to state the correct facts, and give all a fair chance.

### Sharp Points.

The following are some of the points taken on the argument in favor of continuing the temporary stay granted Jacob Sharp until a motion for a new trial can be made before the General Term in October:—Each of the jurors entered the jury box with an expressed opinion against Mr. Sharp.—Suppose Mr. Sharp had gone upon the stand, what could he have said except that he was not guilty? He had said this already.—The statement that a number of Aldermen had fled should not have been admitted. Mr. Sharp remained here and stood his trial. The law was trampled upon in order that vengeance might be taken upon him.—The two most important exceptions taken during the trial were those regarding the Pottle testimony and the admission against Mr. Sharp of his own evidence forced out of him by the Senate committee.—Mr. Sharp should not have been compelled to answer for more than one crime, yet evidence was admitted in an attempt to show that a year before the Broadway franchise was granted he had tried to bribe Pottle.—There is no doubt that Pottle's testimony was wilful perjury.—Falseness and prejudice were spread upon the record.—That Senate investigation was the corner stone of this conviction. Mr. Sharp was compelled to testify before that committee, but now, by Judge Barrett's decision, we can never get another conviction, because no man need open his mouth before a legislative committee. This is the first case in this State where a person has been convicted of bribe giving, and it will be the last unless a higher court sets aside this decision or the Legislature frames new laws.

### Car Fares in Copper.

"Pennies!" sniffed the conductor contemptuously, as he rung up the fare. "What's the matter with pennies?" asked the passenger.

"Oh, nothin'," said the conductor, "pennies are well enough. You can get postage stamps with 'em, or give 'em away to the children for candy, or then again you can buy a newspaper with 'em of a mornin'. But they don't go with us conductors very well. Why, those copper coins are the greatest nuisance going. Can't we turn 'em in to the company? No, we can't, because the company won't take 'em. We have got to shoulder them ourselves. Yes, sometimes we can shove 'em off a few at a time on passengers, but the passengers kick if they get more than five, and even then they, nine times out of ten, look as if they had been insulted. We have to make pennies good ourselves to the company, and so we get pretty near our whole week's pay in coppers. Pennies will make me grow gray soon."

The passenger took back the copper coins he had tendered, and pushed a silver coin into the conductor's hand.

"Why, that, now," said the conductor, "that's pretty near as bad as copper; that's a Canadian five-cent piece, and the company kicks if we turn in more than two or three Kanuck coins on a trip. Yes, sir; now you're talking; that's a good, honest Uncle Sam nickel, and that goes every time."

### Personal.

F. DE H. ROBISON was lately in Saginaw.

A. W. LYNN, of the St. Clair St. Ry. Co., Cleveland, O., was East recently.

D. F. LONGSTREET's name appeared in the "Stillman" register, Cleveland, lately.

JULIUS S. WALSH was recently at Coney Island.

CHAS. HATHAWAY has been visiting Milwaukee, Wis.

A. W. HATHAWAY, Cleveland, O., with the assistance of a fair companion, recently won a canoe race and a dinner at Put-in-Bay.

MR. HENRY M. WHITNEY is to be the president of the Boston Consolidated Street Railway Company, and Mr. Calvin A. Richards will be the general manager. Mr. Moody Merrill will also have an important place in the management.

PRESIDENT YERKES, of the North Chicago Street R. R. Co. receives as much attention by "the press" as if he was President of the United States almost. All his movements are observed, and his private affairs reported. For instance, the Chicago *Tribune*, Aug. 3, proclaimed that Mr. Charles T. Yerkes has been conveying real estate and personal property to his wife. The consideration mentioned in the bill of sale conveying the furniture and household effects is \$5,000. The real estate was first conveyed to James F. Meagher, the consideration being \$1, and by him to Mrs. Yerkes. What is intended as the description of the personal property conveyed in the bill of sale reads as follows: "All the furniture of every kind, name, and description, all the silver ware, silver-plated ware, glassware, china, crockery, linens, bedding, carpets, musical instruments, pictures, objects of virtu, articles of bric-a-brac, and all other objects of household use and adornment, all in the dwelling house No. 3201 Michigan Avenue, in the city of Chicago."

### POINTERS.

#### ALABAMA.

*Anniston.* Mr. W. A. Davis is secretary of the Anniston Street Ry. Co., who are ready to buy supplies.

*Mobile.* The Mobile Street Railway Co. contemplate various improvement.

Three steam motors will be used by the Mobile and Spring Hill R. R. Co. on the new track previously mentioned.

*Selma.* The Selma St. R. R. Co. are now building their extension.

#### CALIFORNIA.

*San Francisco.* The Powell St. Railway Co., whose cable road is now in course of construction, hope to have it in operation about the second of January next.

The Telegraph Hill R. R. Co. are waiting for the completion of the Powell St. Cable Railway.

The Sutter Street R. R. Co. will construct a mile and a half of new cable road in the near future.

#### ILLINOIS.

*Chicago.* The North Chicago Street R. R. Co. put on two new lines of cars, August 8th, reaching the west side at Milwaukee avenue by way of West Division street, going over the Division street bridge and west on that street to the intersection of Milwaukee avenue. One line, which is known as the "Market and Division" route, starts at the corner of Clark and Washington streets, going north on Clark to Chicago avenue, thence west to Market, north on Market to Division, and west on Division to Milwaukee avenue. Seven cars were put on, and more will be added if traffic justifies.

The second new line is to be known as the "Lincoln park and Milwaukee avenue" route and is being tried by way of experiment to afford west side residents living in the northwest portion of the city an opportunity to reach Lincoln park without having to go to the south side. Four cars were put on and the first nine trips were hardly a success, as but 55 cents was collected. The route begins at the intersection of Milwaukee avenue and West Division street, running northward to the north side to Wells street, thence north to the entrance of Lincoln park at Centre street, and turning west to the intersection of Centre and Sedgwick streets. It takes twenty-five minutes to make the run.



Injunctions were obtained, August 4, by the Chicago, Rock Island & Pacific and the Chicago & Western Indiana railway companies, restraining the Chicago City Railway Company from laying its tracks over the tracks of the complainants at 69th street. The cable cars are now completed to 63d street, and this is the contemplated extension six blocks farther which Judge Garnett enjoined, but only temporarily. The complainants say that the Chicago City Railway Company's charter does not give it the right to cross 69th street and it does not specify a right of way over complainants' tracks, as it ought to do.

It was stated, the middle of last month, that the 4½ per cent. debentures of the Chicago City Railway Company would soon be converted into mortgage bonds. That has since been done, we understand. And a "blanket mortgage" has been executed covering all the property, rights, and franchises of the company, on which it is a first lien. The bonds are payable in 1902, but they may be redeemed at any time previous to that year. The right of redemption will not, however, be exercised, it is stated, except under some very extraordinary circumstances.

We have previously stated the extensions in progress by this company. Nine miles of cable line and between twenty and thirty miles of horse line will be constructed during the year, much of the work being already done. They carry 20,000 more passengers daily than this time last year, and 180 more cars are being built in the company's own shops.

The Metropolitan R.R. Co. was incorporated July 22d, with a capital of \$3,000,000. They proposed to build an underground railway from some point or points in the City of Chicago to nearly all the townships in Cook county, and connect the lines so as to make a system of belt railroad connecting all points touched. The incorporators are Chicago men. Henry W. Leman, a well-known attorney, is one of the most active movers in the new enterprise.

It is designed to lay a tunnel 35 feet under the streets. The lines on the principal streets are to comprise four tunnels, two each for trains moving in different directions, and approached by staircases from street corners at intervals of about half a mile. The propelling force is to be steam, compressed air, electricity, or "other suitable power." The other incorporators (with Mr. Leman) are, Messrs. Eli H. Doud, John Miller, John Gray, John S. Miller and B. F. Chase, all of Chicago. All steps taken are to be open and above board, and no attempt will be made to obtain a charter until the idea has been discussed by the public press thoroughly. In case the matter meets with popular approval it will at once be pushed. If it should meet with vigorous opposition from other sources than existing and rival corporations it will be laid aside until such time as the public wants it. It is estimated that it will be fully three years before any large part of the system will be in operation. The scheme was so satisfactorily discussed in the newspapers that an ordinance was introduced in the City Council, July 25th, and referred to the Committee on Railroads. It provides for proper foot-tunnels and passenger stations, and that the highest point of the tunnel under the roadway shall be not less than fourteen feet. The necessary shafts are also provided for and the obstruction of streets while the tunnels are being built. At least three miles of the new railway system shall be completed within five years after the passage of the ordinance; and five miles additional shall be constructed within every three years thereafter, until the whole system shall have been completed. The company agrees to pay all property damages, and the fare of each passenger shall not exceed five cents within the city limits. The company is also authorized to maintain police and fire alarm telegraph wires with its tunnels and also electric-light and other cables and wires, steam, water, gas, air, pneumatic and other tubes, pipes, and conduits.

The West Chicago Street R.R. Company, has been incorporated by Charles T. Yerkes, president of the North Chicago Street R.R. Co., to acquire control of the one hundred and fifty miles of street railways hitherto belonging to the Chicago West Division Ry. Co. and the Chicago Pass. Ry. Co. The negotiations looking to the securing a control of the stock of the West Division Co. having been going on for

a period covering nearly eight months. During that time considerable stock was secured by the syndicate engaged in the deal, but not enough to give it a majority of the present capital, \$1,250,000. The amount thus far secured is nearly one-third of the capital stock, or about \$400,000 par value, for which \$2,000,000 has been paid, or nearly 500 per cent. more than the original value for which the stock was issued. There are several large blocks of stock which the syndicate would like to have purchased, and for which it would undoubtedly have paid \$510 a share. These holdings include those of Ben Campbell, Jerome Beecher, S. B. Cobb, William H. Bradley, and the stock controlled by J. Russell Jones, the president, as trustee. The holdings of these gentlemen would have given more than a controlling interest to the syndicate, if the other \$400,000 worth of stock is counted in. The hitch was, however, with the directors, the gentlemen named, who are all wealthy. They refused anything less than a guarantee of a dividend of 30 per cent per annum upon their stock, which it was at present paying, or 6 per cent on \$500. Money could not be invested to yield such a large certain per centage—free from taxes and other expenses—and hence they would not release their holdings for ready cash, but instead they signed an agreement to consent to a lease of the West Division Ry., provided their stock was counted in as of value of \$500 a share, upon which an annual interest of 6 per cent, or \$30 a share, should be guaranteed. Ultimately the new company leased the West Division lines for a period of ninety-nine years, agreeing to pay 6 per cent interest upon \$6,250,000 as rental per annum, which is equal to taking all the stock of the company at 500 per cent.

The new company will at once proceed to lay a cable road on all of the principal West Side street lines, and also commence, as soon as possible, the construction of new lines on West Side streets for which the old company held franchises. This deal does away with all contest over the South and West Side loop systems, and the North Side company will now lay a cable track on Washington street. Whether Mr. Yerkes will be president of the new company or not has not yet been decided upon. He is at present in Philadelphia perfecting the deal. The North and West Side systems will be managed as independently of each other as hitherto; and there will be no transfers from one division to the other without paying extra fares. The organization of the old West Division company will remain intact, except that it will have no need for other officers, save a president and secretary, and it will run no street cars; and all they will have to do henceforth is—to live on their incomes.

*Hyde Park.* The South Chicago and West Shore Railway Company has been incorporated by George W. Spencer, F. W. Green, George Willard, and others, and they have petitioned the Hyde Park board of trustees for the privilege of constructing a line of road from a point on the east line of the strand between the Calumet River and Eighty-seventh street, at South Chicago, to Cummings, south and across the Calumet River, at Chittenden's bridge, and thence south-westerly to Dolton, the limits of the Village of Hyde Park. An ordinance accompanied the petition, both of which were referred to the Judiciary Committee. Mr. Spencer said it was fully intended to construct this road if the right of way could be secured.

*Lake View.* The citizens of this thriving suburb of Chicago were delighted, some couple of months since, on receiving a charter of city incorporation, and it threw off its old town privileges and dignities in contempt. The march of progress is becoming so rapid, however, that they are inclined to be slightly alarmed, and fear they are making headway too rapidly in the way of modern civilization.

At a meeting of the Board of Aldermen of the infant city, Aug. 8, an ordinance was passed for extending the street railway on Evanston Avenue from Graeceland Avenue to a point four hundred feet north of Sulzer Street.

Then, at the same meeting, an ordinance granting permission to the Van Depoele Electric Manufacturing Company to operate street cars on Clark Street, from Diversey Street to Lawrence Avenue, was introduced, and laid over under the rules.

But the way Mr. Yerkes pushes his cable railways up there make the people of Lake View rather uncomfortable for the time being, and they grumble at the coming of the grip. The cause of their dissatisfaction, however, is that all the streets are cut up at once. Halsted Street, Clark Street, and Evanston Avenue, and all the principal thoroughfares running north were uprooted at the same time, and travel on them almost completely stopped. Chicago and Lake View have been almost cut off from Rose Hill, Calvary, and the other cemeteries lying north and west, and the long funeral corteges have for weeks been compelled to go long distances out of their way to reach the burying grounds. Had even one of these streets been left open, as might easily have been done, they say, the public would have been saved an endless amount of trouble and inconvenience. The inconvenience will be over all the sooner, and then these grumblers will say that it was the proper thing to do, and by far the best in the end.

**Litchfield.** The Litchfield Street Railway Company was incorporated July 13; capital stock, \$25,000; to build street car lines in Litchfield. Incorporators, J. A. Beverly, H. H. Beach, S. M. Grubbs, B. F. Johnson, and E. R. Davis.

#### INDIANA.

**Indianapolis.** The Cable St. Ry. Co. has been incorporated with a capital of a million dollars. Mr. Joseph R. Jackson is interested.

#### IOWA.

**Preston.** Mr. R. T. Shea, of Ottumwa (this State), has obtained from the Preston City Council the right of way to build a street railway here, which will be about two miles long. It is not known whether Mr. Shea will build the road himself, or have it constructed by contract. Our correspondent says Mr. Shea has returned to Ottumwa, and thinks it probable that the work will be done by contract.

#### KANSAS.

**Abilene.** Contractor Spencer has finished a portion of the Abilene Street Railway—one mile—and had it in operation within the stipulated time, viz., four months from the publication of the franchise. A mile and a quarter more track is being constructed.

**Ashland.** The Ashland Street Railway Company, of Clark county, has been incorporated with a capital stock of \$5,000. Directors: James P. Weeks, Frank B. Brooks, John S. Myers, I. K. Berry and Isaac T. Myers.

**Atchison.** The Atchison St. Ry. Co. (Superintendent Searl) have ordered six new cars of the Laclède Car Co., St. Louis.

**Council Grove.** The C. G. Street Ry. Co. intend to build good stables and car house this year, and purpose laying about a mile of additional track next year.

**Dodge City.** Since the incorporation of the Dodge City Street Railway Co., "poitered" in the July GAZETTE, their franchise has been transferred to a Wichita syndicate, on condition that the road is to be completed and in operation by the 1st of March, 1888. The railroad begins at 4th avenue in Crawford's addition, on the south side of the river, and runs one mile north on Bridge street. It also has two branches each one-half mile in extent. Mr. A. T. Soule has expressed his intention of continuing a line of his own from the north terminus of the main line through his addition, and on to the college grounds.

**Kingman.** The Kingman Street Ry. Co., in compliance with the terms of their franchise, commenced work on the first instant, and "the line will be crowded to completion with all possible speed." Stables will be erected on the Rock Island addition.

**McPherson.** The Salina Street Railway Co., who own the McPherson franchise, had to send a car down, July 28, to save about \$7,000, which would have been forfeited if a car had not been running at the specified time. It is said that the entire population of that little city turned out and took a ride on that car.

**Marion.** The Marion Street Railway Company has been incorporated with a capital stock of \$10,000. Directors: R. C. Cable, C. S. Winslow, W. W. Loveless, and Joseph M. Young of Marion; Samuel L. McClanahan of Fort Scott.

**Newton.** Newton has one and a half miles of street car line in operation and is building five miles more.

**Olathe.** The Kansas City and Olathe Investment and Rapid Transit Co., in conjunction with the mayor and other citizens of Olathe, have made arrangements for constructing a steam (dummy) motor railway from Kansas City to Olathe, in connection with the new Methodist university scheme. Olathe stands good for \$100,000 of the \$150,000 required to be raised by Johnson and Wyandotte counties.

**Ottawa.** The Ottawa St. Ry. Co. intend to lay one mile more track the coming year.

**Parsons.** The Parsons St. Ry. Co. have not yet built their three miles of track. They have purchased rails, ties and stringers, and are waiting further developments in means of propulsion.

**Sterling.** Mr. H. H. Jackman, of Wichita, has obtained a franchise from the Sterling city council to build and operate a street railway in Sterling, and he is to have at least one mile and a half of road in operation within nine months from the date of the passage of the ordinance. His promise to do so is gracefully set forth in the following letter:

WICHITA, KAN., July 18, 1887.

P. P. Truheart, Esq., Sterling, Kan.:

DEAR SIR—Your communication of the 15th inst. informing me of the passage of Ordinance No. 179, granting street railway franchise, is at hand. I shall endeavor to be as prompt in carrying out its provisions as has your city in passing upon and granting the same. After the arrangement of some preliminaries here—which will require a few days—I will forward the City Clerk an acceptance, as required by last section of ordinance. Respectfully, H. H. JACKMAN.

**Topeka.** The Topeka City Railway Company, owned by the Topeka Land and Development Company, has over 12 miles of track in operation, and is capitalized at \$1,660,000. The company is constantly extending its lines, which now reach all the depots, hotels, and most of the public buildings and places of interest in the city. This road has an exclusive franchise on Kansas and Sixth avenues, and the main business thoroughfares. Its traffic grows so rapidly that it is impossible to keep the equipment up to requirements, the road earning now over \$100 per day net, \$200 gross; earnings July 4, \$572. The superintendent of the road, Mr. J. Shaw, in a recent conversation said that "had there been a sufficient number of cars for use on the 4th, 25,000 or 30,000 people would have been carried. A year ago we could take care of all who wanted to ride, now we are unable to meet the demands, had hard work to keep the passengers off the tops of the cars; six new cars are now ordered, and before next 4th we will be able to take care of 50,000 people." The growth of the street car traffic is the best evidence of the wonderful growth of the city.

The "Rapid Transit Street Railway Company" has some twelve miles of road under construction, and will use the "Baldwin Noiseless Steam Motor." The "coaches" which have arrived for this line are greatly admired. In addition to the ordinary hand brake, they are also provided with vacuum air brakes, which, it is claimed, if it is applied, when the coaches are going at the rate of ten miles an hour, can stop the car before going six feet further. Mr. James Ramsey has the contract for building the car shops and headquarters of the line on Jackson and Hunton streets. The company expect twelve closed cars before fair time and motors sufficient to run them. This company can then transport at one time over a thousand people.

The West Side Circle Railway Company, to be run in concert with the Rapid Transit line, is building some three miles of track in the western suburbs, and will prove of direct benefit to the Topeka Land and Development Company in opening up a part of its property.

The franchise of the Topeka Circle Railway Company is owned by the Topeka Land and Development Company, and the road will soon be built out through the lands of the company, running in connection with the city railway. This will be a rapid transit line, giving quick and easy access to the centre of the city from all points of the company's property.



The Highland Park Railway is intended to connect Highland park and other slightly suburban residence additions in that vicinity with the city, and at some convenient point near the centre of the city will make connections with the City Railway and the Rapid Transit systems, thus affording residents of those localities direct transportation to any portion of the city they may desire. This road will be operated by steam motors and be ready for transportation this fall.

The Topeka Deer Creek Railway is rather quiet at the present but the intention is to run a line directly from the city to Deer creek bridge, on the Tenth street road. It will be the only cable road in the city, and will accommodate the residents of Gilmore heights, Irving place and the people in general living east of the city. Another important feature of this road is the traffic in furnishing stone to the city, which it can command.

**Wichita.** The Wichita City Railway Company has received an invoice of 27 mules from Kansas City. The company is now running thirty-six cars, and four more are expected from St. Louis forthwith.

The Wichita & Suburban Motor Line Co. have experienced considerable difficulty in getting tram rail. The demand for such being so great that it is difficult to get an order filled. The rails were ordered soon after the ordinance was passed. It took several months to get the rails made, and some time before they could be delivered. The shipments west are so great that the railroad companies seem to find it impossible to do work as soon as desired.

The Wichita Rapid Transit Co. will add ten miles to their line as soon as convenient. Their road was opened the beginning of July, and during the month the receipts exceeded all expectations; and the road promises to be a paying investment. The capital stock (\$100,000) is all taken; and this is to be increased as soon as possible. The two (Porter) motors, mentioned in June GAZETTE, weigh 8½ tons each.

**Winfield.** Messrs. Clark, Thompson and Ferguson have sold their interests in the Union Street Railway to Messrs. Wm. Mathewson, Robt. M. Piatt and Stewart, all of Wichita. These gentlemen now have 150 of the 250 shares of the stock which gives them a controlling interest. They will go ahead with the extension of the lines contemplated by the former owners, and they have commenced operations by repairing "Thompson's Switch" on North Main street.

#### KENTUCKY.

**Covington.** The contract for laying the new street railroad in this city was awarded, Aug. 6, to B. R. Martin, of Newport. This is the road that is to go through that portion of the city known as Austinburg. The road will be a great benefit to the people living in the Sixth Ward, and will improve that portion of the city wonderfully. Work will be commenced on it immediately, and it will be all completed this fall. The Sixth Ward is now a picture of industry on account of the railroad work in progress in the ward. The bridge between Newport and Covington will be finished very soon.

#### LOUISIANA.

**New Orleans.** It is proposed to use electric motors on some of the street railways in this city; but whose motor to choose has not yet been decided.

The franchise of the Canal and Claiborne St. RR. Co. is still "in the market." The council resolved to advertise for proposals. And they have decided, by a vote of 5 to 2, that in case the present company does not prove the successful bidder it be allowed three months in which to take up its tracks and the new company be allowed three months more in which to rebuild.

#### MASSACHUSETTS.

**Boston.** The Metropolitan Railroad Company propose to place a single track in Hudson street, Dorchester, and to change the location of the single track in Hanover street, between Commercial street and Chelsea ferry, and to construct an additional track from the terminus of their double track on Hanover street to Chelsea ferry. These proposed changes and additions have been submitted for consideration by the committee on horse railroads.

The South Boston Street Railroad Company is at work upon the new track leading off from Broadway, along Dorchester street, to connect with the line on Dorchester avenue, which will afford increased facilities for passengers traveling between South Boston and Dorchester, *or vice versa*.

**Cambridge.** The Cambridge Street Railway Company has obtained the right to establish and maintain the electric motor power in propelling its cars on North Harvard street, from Western avenue to Cambridge street, ward 25.

W. E. Plummer and J. A. Enos have petitioned for leave to erect posts on Boylston street, and to place an underground cable under the edge of the sidewalk, as an auxiliary system for running street cars by electricity.

**Pittsfield.** The Pittsfield Street Railway Company has had two rival boards of directors to manage its affairs for some time! Fortunately, both boards appointed Mr. F. Guild as manager and treasurer, and Mr. C. P. Upson as superintendent—else matters might have been worse. The stockholders have rescinded all transactions and votes passed by the self-constituted directors of the "Boston Syndicate," so called.

**Plymouth.** The Plymouth and Kingston Street Railway Company are doing nothing but "waiting electrical developments." But they say their road "will, without doubt, be built in the spring of 1888, if accumulator system of running by electricity is perfected." They are confident that their charter, which has expired, will be renewed as soon as they are ready to proceed with the construction of their road.

**Quincy.** Twenty-five prominent citizens recently met to consider the advisability of constructing a horse railroad in this town. Mr. Herbert M. Federhen is chairman and Mr. Warren W. Adams secretary. In response to requests for information a report of facts ascertained by recent investigations was made by Messrs. W. F. Lunt and J. F. Merrill, their estimate for building and fully equipping between four and five miles of road, connecting the Point, South and West districts with the Center, being about \$34,000. After some discussion, in which the opinions expressed were on the whole favorable to the proposed road, the following-named gentlemen were appointed a committee to investigate the matter and report at a future meeting: Theophilus King, H. H. Faxon, John R. Graham, Thomas Fenno, W. T. Babcock, William D. Webb, George L. Gill, John Federhen, W. F. Lunt, Fred. H. Smith, John E. Drake, Warren W. Adams, Levi Stearns, J. F. Merrill and H. M. Federhen.

**Revere.** An electric motor drawing two passenger cars over a narrow gauge railroad is running very successfully, during day and evening to and from the Point of Pines, for a distance of half a mile. A speed of 15 miles per hour can be attained.

#### MICHIGAN.

**Grand Rapids.** The Cable Railway Co. of Grand Rapids has been incorporated by Robert Wetherell, etc.; capital, \$500,000.

The Valley City St. Ry. Co. has been incorporated, to use cable and horse power; capital, \$200,000. President, Wm. P. Innes; Sec'y and Treasurer, Robt. W. Innes.

#### MISSOURI.

**Kansas City.** Another gigantic street railway ordinance has been presented to the city council. It comes from the "McGee, East Seventeenth Street & Suburban Railway Company," of which the directors are B. F. Jones, George W. Warder, L. E. Irwin, Robert S. Adkins, Isaac Whitaker, John W. Moore, Ed. H. Webster, W. O. Thomas, George Hoffmann, T. H. Edwards and M. J. Payne. The scheme is to start a road on Cherry street, near Springfield avenue, run over Sam C. Schaeffer's road, Kansas City, Mastin Park & Westport railway; then run from Twenty-seventh street north on McGee to Seventeenth street, thence to Bellefontaine avenue, along the avenue to Fifteenth street, along Illinois avenue from Fifteenth to Thirteenth, on Thirteenth from Illinois to Cleveland avenue. They propose using twenty-two tons smokeless motor. Three-quarter charcoal and one-quarter anthracite or naphtha will be used as fuel, which will be smokeless. In a statement sent out with

the ordinance, for the benefit of the aldermen who will pass upon the matter, the following claims are set forth:

The engine will be noiseless and can draw over 500 tons, or about thirty ordinary cable cars and nearly 500 people. The top of the rail will be level with the top of the street, and filled in between the rails with Colorado stone or block paving, as the council may require, and vehicles can run over the track at any point on the line without molestation or inconvenience. The cars to be used will be first-class in all respects, with electric bells inside having direct communication with the engineer to stop the train. Each car will carry thirty-eight passengers. Excursion cars will carry 80 passengers. The cars are from 26 to 34 feet long. The grades will be the same as those adopted by the city. The fare will be 5 cents, and will divide same with connecting line carrying passengers to any road through the city.

This road (in the city) will cross from Twenty-seventh street to Thirteenth street, making fourteen avenues, and will communicate with the fourteen streets thus crossed. With this connection on the outside of the city, the Kansas City, Mastin Park & Westport Railway, it will cross all the cable lines south to Fussell avenue, or Thirty-third street, and it will further cross all the avenues from Thirty-third street in and out of the city to East Fifth street, being twenty-eight avenues. It will thus communicate with every avenue running south and every avenue running east out of Kansas City, crossing all cable lines, crossing the Belt line, and by means of communication with cable lines it will communicate with every railroad, every cable line, every street, every store and church, and almost every house in Kansas City, and will also communicate with all the points within twenty miles of Kansas City.

*St. Louis.* The Citizens' Ry. Co. are enthusiastic in changing to the cable system.

Judge Laughlin is endeavoring to obtain a franchise for his proposed cable railway, in which he is vigorously opposed by residents on Grand ave. and others. The principal objection is against running the road down the alley just south of the Grand Avenue Presbyterian Church to and across Grand avenue. This plan if followed will cross Grand avenue with two tracks.

#### NEW JERSEY.

*Keyport.* The Keyport & Matawan St. Ry. Co. has been incorporated, and their road (3½ miles) is being constructed as rapidly as possible.

*New Brunswick.* The New Brunswick City Railroad Company has applied to the city council for permission to use electric motors of the Van Depoele system on its cars.

#### NEW YORK.

*Brooklyn.* The Park Avenue cable road, in Brooklyn, which began operations five months ago, has stopped, and people along the route were surprised to find that the little one-horse cars of the Crosstown road had taken the place of the bright yellow and orange cars which the Cable Company had in use. This notice in the new cars served to explain the situation in part:

#### To the Public:

The Brooklyn Cable Company having, by reason of a recent decision of the court, been prevented from extending its cable road through Central avenue as contemplated, it has made arrangements for an extension in another direction, which, until the completion of the cable road, it will operate with smaller cars. It is hoped that the reason for this change will be understood by the public.

#### THE BROOKLYN CABLE COMPANY,

TOM L. JOHNSON, President.

The work of laying the foundations for the Kings County Elevated Railroad, in lower Fulton street, Brooklyn, has been commenced. A force of men started to work at Fulton and Adams streets, near where the first span of the structure was erected nearly two years ago. All the foundations from that point to the old city line at Sackman street, have been put in, and by September 1 all will be laid to Fulton Ferry. The structure has been put up from Grand avenue to Adelphi street, and much of the iron work to Flatbush avenue is ready to go up. President Jourdan says

that the road would be running from Fulton Ferry to Franklin avenue by December 1.

A "tie-up" has occurred here again. This time it was the engineers on the Brooklyn elevated roads that "struck," July 11, causing temporary inconvenience; but their places were soon filled up. The strikers endeavored to alarm the public by proclaiming the "green" hands as incompetent. The fact is, three engineers and six firemen of the Brotherhood of Locomotive Engineers had been discharged for incompetency; and that seems really to have been the chief cause of the strike. They also demanded shorter hours and increased pay. The State Board of Arbitration assembled in the Brooklyn Court House, July 15, "to adjust the strike" on the Brooklyn "L" Road. Owing to the absence of one of the counsel for the strikers, an adjournment was taken until 2 P. M. The management of the road assert that they have secured all the men they need. The session was taken up with evidence on behalf of the strikers, who declared that the members of their committee who called on the manager were cursed and discharged. The enquiry was continued next day. On behalf of the railroad Colonel Martin said he had instituted a civil service system for the promotion of firemen to engineers. Regarding the income of the road Colonel Martin said interest day had never yet come round without some part of it having to be made up by the stockholders. The men whose discharge had caused the strike were dismissed because they had violated the rules, and it was impossible to grant all the demands of the strikers. He admitted having been rather excited when the grievance committee called upon him. In answer to a question, he said there was no chance of a compromise, as the vacancies had all been filled. The investigation was then declared closed. The commissioners of arbitration will include the result of their labors in their report to the Legislature next winter.

*Buffalo.* Fire has destroyed the barns of the Buffalo Street R.R. Co. Fortunately no horses were roasted in this conflagration, and the losses are covered by insurance. The fire originated in an adjoining brewery. President Watson and his company are to be congratulated that worse damage did not happen.

*Flushing.* The Flushing and College Point R.R. Co. have obtained a franchise from the village trustees to build a street railway from Flushing to College Point, which is to be finished and in operation by the second of January next. This village has shown much precocity in the way it has granted this franchise, and the railway company have to pay therefor four and one-twentieth per cent. of the gross receipts for the first ten years, one per cent. additional the second decade, and another one per cent. (total 6½%) thereafter.

*Hudson.* A franchise for a new street railway has been sold by auction, at the Mayor's office. The successful bidder was Mr. Edward J. Hodge—he offered a dollar and a quarter, and for that sum it was knocked down!

*New York.* The application of the New York Cable Railway Company for an order sending back to the Commissioners their report, so that there could be a rehearing in regard to certain routes, has been denied by the general term of the Supreme Court.

At the fourth meeting of the new Rapid Transit Commissioners, Mr. Calvin Goddard applied, on behalf of persons interested in the New York Underground Railroad Company, for permission to begin the work of construction. Mr. Goddard said that he represented, among others, Adolph Ladenburg, J. Coleman Drayton, A. Belmont, jr., Sir Roderick W. Cameron, Heman Clark, J. D. Cheever, John H. Davis, William Mertens, Richard Irwin & Co., and James T. Woodward. The route of the company, Mr. Goddard said, would be from the east side of Broadway at the junction of Park row, under Park row to Centre street, under private property to Elm, under Elm and Marion, and under private property and intervening streets to the point of connection with the route already laid out for the New York Underground Railroad Company at Lafayette place.

Mr. Goddard submitted models of the electric motors and rolling stock for the proposed road, which he said was



being made at the Rhode Island Locomotive Works at Providence.

The application of the Metropolitan Transit Company for the appointment of commissioners of appraisal to ascertain the compensation to be paid to the city for the use of Broadway and other streets, which are desired by the company for its proposed elevated railroad, has at last been put into the hands of Judge Donohue.

Messrs. Elkins and Widener, and other Philadelphia capitalists, now own the Seventh avenue and Twenty-third street lines. They pay a rental of \$125 to Receiver John O'Brien. In addition they pay the city \$40,000 a year, and three per cent of the gross receipts, together with a license tax of \$50 a car per annum. Last year the city received, from this source, about \$90,000.

Ground has been broken in Fulton street for the new cross-town street railway which is to run by electricity. The railroad, which is the first one to be built under the Cantor Act, will run from Fulton Ferry, with a double track, through Fulton street to West street, and along the Belt Line tracks to Liberty, Cortlandt, Barclay, and Chambers streets ferries. Work is proceeding rapidly and, unless something unforeseen happens, it is expected that cars will be running on the route on or before October 1st. The road will be run by the Bentley-Knight electric motor. The treasurer of this company gives the following figures as actual cost of the three different methods in use: Electric tramway, \$50,311 per year; horse tramway, \$106,820 per year; cable tramway, \$85,058 per year.

**Rochester.** The Rochester City & Brighton Street Railway Company and the Rochester Electric St. Ry. Company are engaged in a struggle for the possession of the boulevard to Charlotte, a distance of between five and six miles. Neither company can accomplish its wishes on account of the numerous legal injunctions that have been laid. The Electric railway has been enjoined by the diocese of Rochester and the Holy Sepulcher Cemetery Association from laying its tracks in front of their property on the boulevard. The Rochester City & Brighton Company has been enjoined by the Boulevard Company from laying its tracks on the boulevard. Patrick O'Brien has procured an injunction against the trustees of the village of Charlotte to prevent them from allowing the Electric Company to lay its tracks in the village, and one against the Electric Company against constructing the road. James W. Whitney, one of the trustees of the Boulevard Company, and as well a stockholder in the Rochester City & Brighton Company, has obtained an injunction forbidding the Boulevard Company to transfer its rights and privileges to the Electric Railway Company.

#### OHIO.

**Cleveland.** There is a fierce street railway war here. It came officially under the notice of the Board of Improvements July 11. The contention is between the Woodland Ave. & West Side RR. Co. and the Brooklyn Street RR. Co., over the right to lay tracks in Franklin avenue. The West Side company (of which Mr. Hanna is president,) desire to run a single track through the avenue from Pearl street, while the Brooklyn company (Tom L. Johnson, president) must occupy the same territory in order to build their proposed double track line through Church and State streets, Franklin avenue and Harbor, Randall and Burton streets. Mr. Johnson said: "Threats have been made by Mr. Hanna, that the West Side company would reduce their fare to two cents, in case we put our line through, and that J. H. Wade and other wealthy men would spend thousands of dollars to prevent us from doing it. But it's good railroad territory, and a great many people will be accommodated, and we are going ahead just the same." After several sessions and heated discussions, the matter stands unsettled.

While the presidents of various roads are contending, the Cleveland Street Railway Employees' Benefit Association have been very sociable, and arranged a grand picnic at Shadduck's Lake Park, near Vermillion, accompanied by a full orchestra, the programme embracing a game of foot ball between the Broadway and Superior street lines, base

ball between the Woodland and West Side and the Brooklyn lines, sack races, wheelbarrow races, potato races, fat man's race, a running race, a boat race, and a tub race.

**Cincinnati.** On July 18 Judge Taft dissolved the restraining orders heretofore allowed against the Mount Auburn Cable Railroad Company preventing the raising of the bridge over the canal on Sycamore street. He held that the raising of the bridge twelve inches would not injure the abutting property. The company was liable to the abutting property owners for any damage, and if it gave bond protecting the city, the injunction would be dissolved.

Some time ago the Consolidated Street Railroad Company's Directors decided to purchase the Mount Auburn Inclined Plane Railway. This was one of the moves made in opposition to the Mount Auburn Cable Road, now being constructed. J. M. Potter, a stockholder of the Consolidated and also of the Mount Auburn Inclined Plane Company, objected to the purchase and filed suit to enjoin consummation of it. Judge Evans heard the case July 30, and declared that the one road could not purchase the other, according to the laws of Ohio; and the proposed consolidation was enjoined.

At the council meeting Aug. 5, Mayor Smith "sat upon" the Mount Auburn Cable RR. Co., and vetoed the ordinance for the proposed extension of Route No. 22.

**Findlay.** Street cars and rails are wanted here. Messrs. Thorp and Andrews will build a street railway from their rolling mills to the court house, a distance of three miles. Their mills are to be ready for operation October 1st; and it is desirable to have the street railway finished and in operation by that time.

**Lima.** The Lima St. Ry. Motor and Power Co. opened their electric road on the Fourth, and caused great excitement among the inhabitants. Ten thousand passengers were carried during the day, with five cars. Van Depoele's is the system used.

#### PENNSYLVANIA.

**Allegheny.** President Scaife informs us that the Nunery Hill Inclined Railway will be opened October 1st. This is a short cable line, rising 200 feet in a length of 1,200 feet.

**Carbondale.** The Carbondale and Jermyrn Electric Ry. Co. are constructing four miles and a-half of track, standard gauge. They will have two cars, with Sprague motors, in operation by October 1st.

**Philadelphia.** Two organized companies—the Consolidated Transit and the Philadelphia and Northeastern are now applicants for rights to build elevated railroads.

**Pittsburgh.** The Federal Street and Pleasant Valley Ry. Co. are "waiting for something to turn up."

The Second Ave. Pass. Ry. Co. are building six additional miles of track, for electric traction.

#### TENNESSEE.

**Memphis.** The street car drivers made a demand for an increase in wages August 4. This, the Citizen's Street RR. Company, which controls all the lines in the city, refused to do. Next day a number of cars were driven by "rats," and while everything passed off much more peaceably than was anticipated, seven headstrong strikers were arrested for interfering with the green hands, unhitching teams and disorderly conduct. There are seventy-three drivers, only forty of whom have quit work. They will lose, of course.

#### TEXAS.

**San Antonio.** The San Antonio Street Ry. Co. "would like full information on electric motors—with the intention of using same, if practical."

#### VIRGINIA.

**Richmond.** The cars on the Union Pass. Ry. Co.'s track (13 miles, now in course of construction) will be heated in cold weather by an electrical apparatus invented by Dr. W. Leigh Burton, of Richmond.

#### WISCONSIN.

**Milwaukee.** The Cream City RR. Co. are seeking a franchise for an extension of their tracks northward—over the Dock street bridge.

### Business Notes.

An experienced and thoroughly practical Street Railroad man at present filling combined positions of Sup't, Sec'y and Accountant desires a change, location no object; would prefer taking hold of large failure or entire charge of operating a medium sized road. A 1 opportunity for any President or Company to secure the services of a first-class all-round reliable man upon reasonable conditions. Excellent references from former and present R. R. Companies by whom employed. Address GEN'L MANAGER, 144 E. 45th Street, New York City.

THE Horace A. Keefer Company, Kansas City, has received an order for 6,000 cable yokes and a quarter of a million bolts. The Steinway and Hunters Point R. R. Co. (L. I.) has adopted the Price's fare box, made by this company, for all its cars.

THE Sargent safety rod coupler, illustrated in another part of this GAZETTE, is the invention of Mr. W. W. Sargent, superintendent of the newly incorporated Fitchburg Street Railway Co., of Fitchburg, Mass.

THE Gilbert Car Company will make at Schenectady, N. Y., 150 cars for the Brooklyn Elevated Railroad.

THE Cline Manufacturing Co., whose removal from Monroe St. was caused by fire, are filling orders for their car heaters and patent fuel (in view of coming winter) as rapidly as possible in their new manufactory, 277 and 279 S. Canal St., Chicago.

THE BROWNELL & WIGHT CAR COMPANY, St. Louis, are now finishing up the new equipment for Grand Avenue Cable Railway, Kansas City. The cars will be of the same style as those used on the Market street line of San Francisco, that is combined grip and passenger car, 31 ft. long, with 4 wheel trucks under each end, and will be the first of this class of car built east of the Rocky Mountains.

The interior of box cars will be finished in mahogany, with beveled plate glass mirrors, spring roll up curtains, instead of blinds, and many other new and novel features. It is the intention of the makers to have them the finest in the land, and such of our readers as saw the car shown at the Convention in Cincinnati, built by this firm, will remember what that means.

They have also just completed two very elegant cars for the Woodland Avenue & West Side road of Cleveland.

They have cars in construction for Wichita, Fort Scott and Hutchinson, Kansas; Waco, Texas; St. Paul, Minn.; Oshkosh, Wis.; Aurora, Ill.; Pine Bluff, Ark.; Independence, Mo.; Lincoln, Neb.; Denver, Colo.; besides electric cars for St. Louis and Wichita.

In order to keep up with the demand for their work, they are now extending their plant, so as to give them double their present capacity.

THE Meigs Elevated Railway Construction Co., Boston, ask for proposals for manufacturing the girders, posts, bar iron and steel shapes of their girders, posts and rails, according to specifications and drawings to be furnished to any manufacturer who desires to make proposals therefor at a fair cash price. Proposals should state the price per pound of the posts, girders or rails. The way will cover eight miles, its yards and turnouts, in a double line, extending from Harvard Square, Cambridge, to a proper terminus in Boston and return. As two miles of the structure are needed as soon as it can be had, proposals should state how soon after contract each half mile can be delivered.

THE Sherman Iron Works, Sherman, Texas, have recently enlarged their premises considerably; and they are prepared to build street cars, among other things.

MR. EDISON, it seems, has a lively young rival in the electric field in the person of Frank E. Fisher, manager of the Detroit Electrical Works. Mr. Fisher is only 27 years old, a native of Detroit, and has turned out over fifty ingenious and useful devices, the latest an electric motor now in use in that city.

THE Car Track Friction Appliance Company manufacturers of the Reliable Sand Box for horse, cable and electric street cars are crowded with orders. Among their recent orders are the North and East rivers lines. New York; the Allegheny City, Pa., Moonshcket, R. I., Pullman Palace Car Co., besides several smaller orders. The Reliable Sand Box is an improvement which all street railroad companies will, eventually, adopt on account of its inexpensiveness, economy and positive efficiency.

LIVELY times are anticipated in Omaha. "Street railway extensions are being made on every side, and are continued out several miles into the country. This will enable strangers to take their lunch, go out, look over the city lots, and return in the evening, tired and ready to sleep, perchance to dream of the fortunes awaiting them on the sale of land just purchased. Cable cars are also being laid. Two corporations are in the field."

THE Armington and Sims Engine Company has been long cramped in its present quarters at Providence, the growing demand for its well known engines having far exceeded its facilities. The company now makes the announcement that it has purchased the Monohasset Mill property, whither it will remove as soon as possible.

### Patents.

The following list of recent Patents relating to Inter-mural traffic is specially reported for THE STREET RAILWAY GAZETTE by Wm. H. Henderson, Solicitor of American and Foreign Patents, 925 F Street, Washington, D. C. A copy of any of the following will be furnished by him for 25 cents.

- 365,340. Swivel truck for electric railways—B. F. Hamilton, Boston, Mass.
- 365,487. Emergency brake for railway cars—J. W. Post, New York, N. Y.
- 365,511. Railway bedding—F. X. Georget, St. Louis, Mo.
- 365,766. Cable railways—F. H. Morse, St. Louis, Mo.
- 359,665. Car brake—J. Bryan, Canton, Ohio.
- 359,880. Car brake and starter—T. Miller, Jersey City.
- 359,874. Automatic car brake—R. E. Linham and R. M. Agnew, Mansfield, Ohio, and Lancaster, Pa.
- 359,664. Conveyor for street car fare boxes—G. R. Brownrigg, Minneapolis, Minn.
- Re-issue 10,821. Cable grip for cars—T. Kerr, New York.
- 359,662. Device for supporting and operating street cars—A. G. Bierbach, Milwaukee.

*Issues of July 5th, 12th, 19th and 26th, 1887.*

- 366,119. Cable road for street cars—C. Leavitt, Cleveland.
- 366,015. Fender for street cars—A. J. Mason and G. C. Hale, Kansas City, Missouri.
- 365,964. Cable railway construction—Z. P. Boyer, Philadelphia, Pennsylvania.
- 366,031. Permanent way of railways—E. Samuel, Philadelphia, Pennsylvania.
- 366,418. Car brake—M. A. McCarron, Detroit, Michigan.
- 366,430. Car brake and starter—T. Sanders, Amsterdam, Netherlands.
- 366,448. Automatic car brake—E. Beals, Norwich, N. Y.
- 366,507. Grooved girder rails for street cars—C. A. Richards, Boston, Mass.
- 366,199. Cable railway—G. B. Bryant, Philadelphia, Pa.
- 366,545. Railway rail—W. Wharton, Jr. & E. Samuel, Philadelphia, Pennsylvania.
- 366,497. Curved crossing for street railways—A. J. Moxham, Johnstown, Pa.
- 366,598. Movable tongue switch for street railways—A. J. Moxham, Johnstown, Pa.
- 366,627. Tramway for elevated railways—B. F. Hamilton, Boston, Mass.
- 366,811. Combined street railway rail and conduit—G. C. Bolgiano, Baltimore, Md.
- 367,137. Cable railway—G. W. Douglass, San Francisco.
- 367,252. Elevated gravity and cable railway—L. A. Thompson, Philadelphia, Pa.
- 367,086. Cable propulsion for railways—R. F. Bridewell, San Francisco, Cal.



# The Street Railway Gazette.

VOL. II.

CHICAGO

SEPTEMBER, 1887.

NEW YORK

No. 9.

## The Daft Electric Railways.

"Benjamin Franklin" is the name of the Daft electric locomotive, shown with train of passenger cars in the accompanying cut, which is shortly to be placed in operation on the Ninth Avenue Elevated Railway, New York. "Benjamin" was "christened" as far back as 1885. The original "Ben" used to thank God for his vanity—above all other graces—and if Franklin's soul is still interested in earthly electricity and conscious of the honor in which the sons

hold a meeting, and an attempt was made to consolidate their interests—so as to carry out a great undertaking. A commission was appointed (Sir William Thomson being one of the members thereof) to test the various electric motors, and the best system was to be adopted. But such a scheme, as might have been expected, collapsed; and the only good it did was to act as a stimulus for separate companies to "push" their own systems. The Daft people were the first in the field in the Empire City, and they obtained permission to equip a section of the Ninth Avenue Elevated Railway

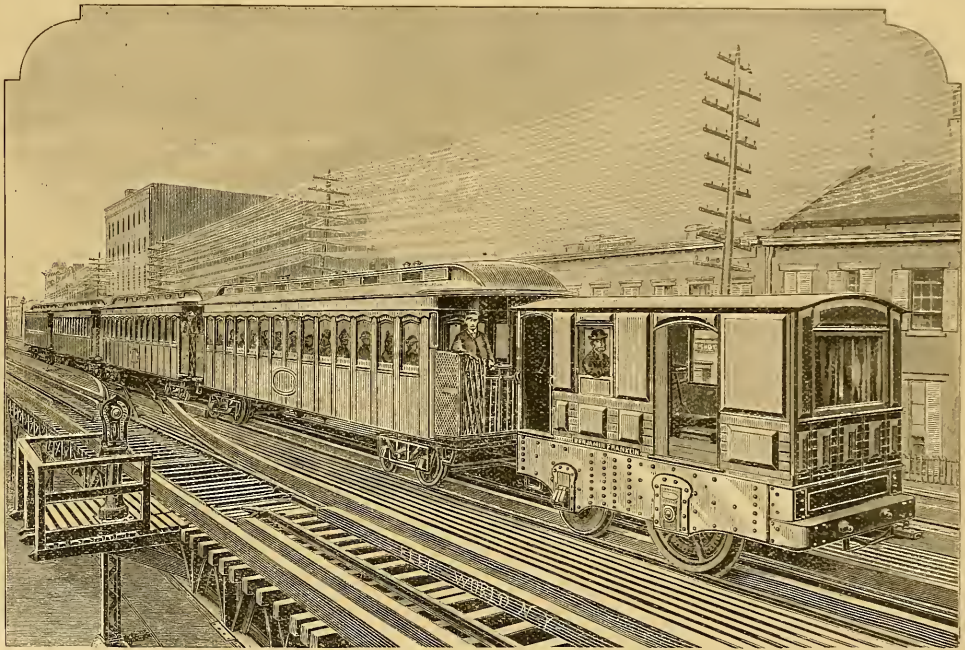

DAFT ELECTRIC TRAIN, 9TH AVENUE "L" RAILWAY, NEW YORK.

of men (especially electricians) delight to hold his memory, he must have felt flattered more or less when the Daft electric motor was placed on the New York elevated railway, some couple of years since, bearing the name "Benjamin Franklin." The Daft experiments subsequently have attracted very marked attention and been the subject of many columns of newspaper "matter."

The Daft Electric Light Company was prompted to make the venture they did in this way: Electric railways had been in existence several years before then—especially in theory, and some successful experiments had been made. And the idea had been developed by the beginning of 1885 so far as to induce the various electric motor companies to

(on the Daft system), while the Edison-Field experiments were assigned to the Second Avenue "L" road.

The Daft experiments were carried on where there are heavy grades, viz.: from 14th Street station to 53rd Street. They readily attained a speed of twenty miles an hour with "Benjamin Franklin," the central rail leading the current to the motor being elevated above the outer ones. "Benjamin" made several runs admirably, and apparently everybody were quite satisfied, except Mr. Leo Daft, the electrician, himself. He considered the motor too light to do the work required of a motor on the elevated railways, and Ben was withdrawn to have the weight increased. The motor was of 75 h. p., but when remodeled its capacity was increased to 125 h. p.

Then it was satisfactory to the electrician and all parties. But when everything appeared to be working well, the Elevated Railway Company found fault with the conductor—a central third rail—then in use. They maintained it was an inconvenience to their steam locomotives, and requested the substitution of some other conductor. A copper rod, five-eighths of an inch in diameter, outside of and parallel with the track, was decided upon; and the preparation of over four miles of this, with the necessary insulators, expansion joints, switches, etc., and the subsequent connecting, without interrupting for a moment the routine service, was ultimately accomplished.

Our illustration represents "Benjamin Franklin" as the motor now appears. In our next issue we may be able to state that it is actually "in harness."

In the meantime the Daft system of electric railway propulsion is in successful operation in other cities. In the STREET RAILWAY GAZETTE for February, we stated that the Los Angeles electric railway, which is operated by the Safety Electric Railway and Power Company's motors (Daft system), was a splendid success. There the conductor is an overhead wire. Next month the Los Angeles *Illustrated Herald* declared that "the Los Angeles electric road is undoubtedly the most successful electric road in the United States. Col. Howland secured the benefit of the working of other roads and adopted the best improvements that experience could suggest. The speed of the road is usually from 10 to 12 miles per hour, as fast as is deemed safe for the streets of the city. The apparatus is under the most perfect control and can be stopped on the instant, and if necessary, be reversed in motion. Cars have been run at times at a speed of 20 miles per hour. The road has been running nearly two months and not failed a single day. It has carried in a single afternoon on three cars, a distance of three miles, fifteen hundred passengers. This road is one of the many enterprises that Los Angeles contributes to astonish the visitor, and is daily visited by hundreds of our sojourners."

That was last March. And the Los Angeles *Times* of March 5 said that its representative had been so fortunate as to elicit the opinion of a leading street railway man (Mr. H. C. Moore) of San Jose, who said: "We heard about your electrical road; I came down and see it for myself, and am surprised at the success and smoothness of your road. I have ridden over it, and must say it is the smoothest riding road I ever rode on. You actually cannot tell, unless you watch some stationary object, just when you start and when you stop."

Our New York representative called at the office of the Daft Electric Light company in the Borel building, and there found Mr. Daft's assistant, Mr. Thos. Whiteside Rae, who replied to his questions as follows:

I hear you are building some motors for a street railway in Pittsburgh which are a step ahead of anything yet turned out. Can you give me any points about them?

Certainly! the road is the Pittsburgh, Knoxville and St. Clair street railway, and we shipped a motor—the first of five—on the 27th of August. These motors are of 35-horse power each, weigh six tons apiece, have a wheel-base of five feet and a length over all of ten feet.

That power must be greatly above the needs of ordinary street railway service. Why is it provided?

The line includes a gradient of 7.42 feet per mile—over 14 per cent.—and 35-horse power is only a prudent provision for taking a fully loaded street car up it at three miles an hour.

You don't mean to tell me that the motors with a car ascends such a gradient by natural adhesion?

I have little doubt but that it would do so with the rails clean and dry—especially as we use them for the return-circuit—but as this condition would be exceptional, a kind of rack, or a perforated band of heavy iron plate, is laid longitudinally between the rails, on this extreme gradient, and a strong sprocket-wheel on the motor, in gear with the driving axle, is dropped into, and lifted from it, at will.

Can this be relied on under all circumstances?

We have subjected it to the severest tests we can devise, and *know* the factor of safety to be considerably more than

three, and believe it to be much larger. The greatest resistance to traction that we engage to overcome is 3,500 lbs. and the motor in question caused our dynamometer to give way under a pull of considerably over 10,000 lbs. How much more it would pull I cannot say positively, but in all probability the factor of safety lay between four and five.

Is the sprocket-wheel used on going down grade?

It is, of course, available for the purpose, but the motor can be controlled electrically on descending gradients, and this will, no doubt, be sufficient, unless under very exceptional conditions.

How does this electrical controller work?

The motor running under the influence of gravity alone becomes a dynamo, delivering a current opposite in direction to that which it receives as a motor, and this current is passed through variable resistances, which operate precisely as a contracted pipe upon a stream of water, and retard the revolution of its armature. This retardation, being adjustable, makes a very effective brake.

Is the conductor overhead or underground?

Both. Within city limits the conductor is in a conduit, not unlike that used in cable railways, but of course very much less in size and cost. On reaching the suburbs, the collector is withdrawn from the conduit, the trolley wires connected, and the motor proceeds by overhead conduction.

Did you have trouble with the municipality about erecting poles?

Not anything to speak of. Pittsburgh is a notable contrast with other towns I could mention where we have had infinite trouble. True to our national characteristic of carrying everything to extremes we have allowed a well-founded objection, to forests of huge unsightly telegraph poles with their tangled meshes of wires that defeat the most energetic efforts of firemen at every conflagration, to extend to everything bearing the name until the cry of pole! excites as irrational a fear in the community as the cry of "mad dog." An artistically designed pole of metal or wood of moderate height, and bearing at the most a couple of wires, may be a positive ornament to a street instead of a blemish and can never facilitate the burning up of houses and occupants. It is a horse of another color from what is known as a telegraph pole, and when the community has sufficiently recovered its mental equipoise to regard the matter calmly it will see it.

Are there any other points of especial interest that you can give me?

This is about all that would interest a general reader, but you might say that with the exception of the "Ben. Franklin," which Mr. Daft designed for the Ninth Avenue Elevated Railroad—and which will be at work this autumn—the Pittsburgh motors are the most powerful electric locomotives ever built. Experiment has shown, that, with the aid of the sprocket-wheel, one could draw sixty loaded street cars on a level track, and by natural adhesion alone could pull twenty.

Are you busy on other work?

Yes. The Daft company is either building, or under agreement to build, eight electric railways in various parts of the country. Pittsburgh, Mansfield, (Ohio), Asbury Park and St. Paul, Minnesota, are approaching completion. Ithaca, N. Y., and Easton, Pa., are just being begun. Findlay, Ohio, and Worcester, Mass., will soon be taken up.

### American Street Railway Association.

The forthcoming convention (sixth regular annual meeting of the Association), commencing Wednesday, October 19, will be held at the Continental Hotel (in Room C), Philadelphia. This meeting is looked forward to with great interest. The prospectus comprises papers on "Cable motive power," by Mr. Tom L. Johnson (Cleveland); "Electricity as a motive power," by Mr. William Wharton, jr. (Philadelphia); "Motors other than cable or electric," by Mr. D. Atwood (Milwaukee); "Roadway construction," by Mr. Calvin A. Richards (Boston); "Street railway mutual fire insurance," by Mr. John Maguire (Mobile); and "Practical devices useful in the economical management of street railways," by Mr. De Witt C. Cregier (Chicago).



### The West End St. Railway Co., Boston.

This rising company, which is to absorb all the street railways of cultured Boston, has applied for permission to increase its capital stock, from \$80,000 to \$1,200,000. The movements of this company and of its promoters have attracted much attention from the onset, and many columns of newspaper space have been occupied with reports of meetings, etc., connected therewith. The *Boston Herald* of Aug. 25 has over five columns (mostly small type) of a report of one day's inquiry before the Railroad Commissioners, concerning the petition for increase of capital; and this was but a resumption of the inquiry. The mouthpieces of the opposition made such terribly long speeches, that go far to show that the Hub has abundance of the gas of speech, if it is not yet supplied with natural gas. The sum and substance of it all may be thus stated briefly: Mr. Henry M. Whitney, president of the West End Street Railway Co., went about quietly buying a lot of land for a land company, which was really wanted for widening streets for the new street railway, and he successfully promoted the interests of both companies (the land and the railway), and managed to buy all the land wanted at a reasonable cost; whereas, if the real purpose of Mr. Whitney had been known throughout, and the railway company's capital had been larger, exorbitant prices would have been demanded for land. Thus extortionists got left, and then they sought revenge by putting as many hindrances as possible in the way. It was endeavored to show that the railway company had deceived the public by seeking and obtaining only \$80,000 stock at first, while they really intended to want some more. This is what they really did; but most people will commend Mr. Whitney and his coadjutors for their wisdom and sagacity.

The law regarding authority to increase the capital stock of street railway companies is found in the Public Statutes, chap. 113, sec. 15. And also in amendments created by chap. 360 of the acts of 1887, which have substantially and entirely superseded the former provisions. The opponents to the petition endeavored to show therefrom that the increase asked for could not be legally granted. The Legislature has specified that a street railway may have its capital increased "for the purpose of building and equipping a branch or extension of its road upon a location duly granted or extended as provided by law, or for any other necessary and lawful purpose set forth in the petition." It was argued that "other necessary and lawful purpose" did not include the objects of this petition, and that the commissioners should not grant an increase except for extensions that had not been contemplated when the company was incorporated. The Legislature, it was said, "intended only that the persons who organize the corporation should make its capital adequate to the purposes for which that corporation was organized, and that it should only have an increase when circumstances should arise which were not foreseen at the time of the articles of association."

On behalf of the company, it was maintained that, as their plans were not matured when the company was organized, in its infancy the corporation did not know exactly what it might be able to do. They did not know how much money they might want, "and, therefore, they put in the minimum amount required, with the intention to increase the capital from time to time," in the same way that manufacturing corporations increase capital according to requirements.

In reference to the matter of "purchasing a location," Mr. Howe, after briefly sketching the history of the inception and progress of the West End St. Ry. Co. (which has been reported in the *STREET RAILWAY GAZETTE*, from time to time) explained the reasonable right of such purchase. "Can it be a question," he asked, "that if this corporation wanted to go through this block (in which we are) to reach the Tremont house, it would be permitted to purchase it? Now, then, that is similar to the purchase from Brookline and Boston, and is the sense in which we have used the word 'consideration,' as a consideration for and in order to obtain the location. I submit that the corporation has as much

right to spend money for that purpose as for raising the grade or for paving the street alongside of its tracks, because paving the gutter 10 feet away is not at all necessary to constructing the railroad. Assuming that the corporation had the right to ratify these contracts, has it a right to capitalize on this as property? I think it has. I believe that not only corporeal but incorporeal property is meant, and that that construction is put on the word by your honors is evident by the decision in the case of the Charles River railroad and by the evidence of Mr. Cummings.

"As to the cost of this franchise, it is put in at the cost at which it came to Mr. Whitney. In regard to the expenses, it is certain that they were necessary, and that the widening of Beacon street was a necessity, for without it the franchise would not have been granted. I don't understand what the objection of the citizens, whom Mr. Russ represents, is. The statute says that fares must be kept down so that more than 10 per cent. shall not be paid on the property and cost of construction of the company. Mr. Russ says there is no need for such a railroad in so sparsely settled a location, but it seems to me that the selectmen and aldermen have decided that a street railway along that line is a necessity, and it is only for the railroad commissioners to see if the increase is necessary, and to see that it is properly applied. There is no reason whatever why the charge of stock watering should be made, for there is nothing resembling it here."

President Whitney added that, "In regard to the capital of this road, I may say that, as compared with any other, it is apparently large, but the Legislature has authorized the building of a tunnel involving \$1,000,000, perhaps for half a mile of road, and it will require a large capital to do that. It is said that there are only eight miles of road, but I may as well say here that the Suburban Railroad company will be very soon before your board asking for permission to increase their capital, and that will make 13 miles that we will have." There had been hearings Aug. 19, 20 and 22 also.

On Sept. 7, the commissioners decided to increase the capital to \$544,000—less than half the amount asked. This sum includes, for construction and equipment of eight miles of single track, \$240,000; for erection of stations, car houses, stables, etc., \$75,000; for car house and stable lot near Chestnut hill reservoir, \$25,000; for car house and stable on Beacon street, \$168,000; for expense of filling the two preceding lots, \$8,500; total, \$516,500.

### The Rasmussen Cable Railway.

As shown in our Directory, the Newark and Irvington Street Railway company (Newark, New Jersey) have seven miles of track ( $3\frac{1}{2}$  miles of road) in operation. The gauge is 5 ft.  $2\frac{1}{4}$  in., and the rail weighs 47 lbs. to the yard. They run 32 cars, have a live stock of 160 horses. Like many other street railway companies, they have been seeking some other motive power than horses; and President S. S. Batin, with others, have carefully investigated the various systems of street railway propulsion in use for several months past. They went round to see the electric railways in operation, and the motors not yet "in harness," and they came to Chicago, among other places, where they had opportunities to see the grand cable system of the South Side, and the experimental half-mile line of the Rasmussen cable railway at the extreme west end of the Lake street road.

The result of their investigation has been to select the Rasmussen cable system, the peculiarities of which have been fully stated in the *GAZETTE*, and they have closed a contract with F. E. Hinckley & Co., of Chicago, to change their road into cable (Rasmussen plan), the first section thereof to be ready and in operation December 1st. The line reaches from the Pennsylvania depot, on Market street, Newark, to Irvington, and the entire length of cables will be seven miles.

The Hon G. Hilton Scribner, president of the Street Railway Association, of the State of New York, and also president of the Central Park, North & East River R. R. Co. (Belt Line), New York, has made a report to his Board of Directors in favor of the Rasmussen cable system.

### The Riley Elevated Railway System.

From the accompanying illustrations, the mechanical eye will perceive at once the arrangement of material in the structure. Fig. 1 represents a side elevation, and plan view of car and structure; Fig. 2, an end view of the same; Fig. 3, a side and an end elevation of the Riley Truck; and Fig. 4, a plan of the same.

An examination of these drawings shows that resting upon a single row of posts is a strong girder upon which is fastened a centre or main rail.

Twenty-eight inches below this centre rail and parallel with it, and upon each side, is a light rail. The centre rail weighs 75 pounds per yard, and the side rails 25 pounds per yard. Cars forty feet in extreme length, and nine feet in extreme width, weigh 16,000 pounds. Each car has two trucks, one in front and one in the rear. And each truck has four wheels, giving a wheel-base of twenty-five feet. The centre, or principal wheels of each truck tread upon the centre rail, one before the other, with centres four feet apart, and are double-flanged. The wheels upon the side rails described, are set in the same truck, and are, transversely, from centre to centre four feet apart, being single flanged. This truck is centrally pivoted to the car floor, and easily adjusts itself to curves of any practical radius; upon the same principle as the self-adjustment of the Bogie truck. By a single and an effective arrangement of springs, the centre-wheels carry seventy-five per cent. of the load and the remaining twenty-five per cent. is equally distributed between the four side-wheels, which, though not intended to do more than this service, are of ample strength to carry safely the entire car load. This car-truck has much less machinery detail to keep in order than that of the truck in ordinary use upon railroads. It is strong, compact, and light, and capable of passing around sharp curves with less friction than the old railroad truck, where the wheel-base is greater and the axles are united.

back to back lengthwise through the centre of the car, with two sliding doors at each end, so that the centre wheels and their connections are not objectionable in the car space, as they occupy no useful room; or the seats over the trucks can be placed back to back and the balance of the car arranged with regular side seats next to the windows.

This system of elevated railway, though practical for all of the motive forces now in use upon railways, can be readily adapted for the use of electricity as the motive power. The electric power can be applied to both the centre-wheels of the front truck of a forward car in a train of three cars. Our space, however, will not allow us to give a further description of the system when electricity is used as a motor power.

In speaking generally of the Riley Elevated Railway System, we can say that the general system of construction, viz.: that of concentrating the carrying metal in one main central girder—which girder transmits its load directly on the centre of the supporting posts—is one conducive to great economy in construction.

The construction of the road is simple and economical, and the structure is capable of resisting the various strains due to rapidly moving loads. The cars are safe from derailment. Sharp curves can be rounded easily and without danger. The centre of gravity being low, the cars run smoother, with little or no lateral sway or oscillation, and no pounding on rail-joints.

The Riley Railway Construction Company is organized under the laws of the State of New Jersey, and is authorized and empowered to contract for the building and equipping of railways in any part of the United States and their Territories.

Elaborate mechanical drawings showing details of construction under different adaptations, and operating models of beautiful construction can be seen and examined at Number 93 Milk street, Boston, where Mr. F. A. Bartholomew, president of the company, gives complete information and explanation of the

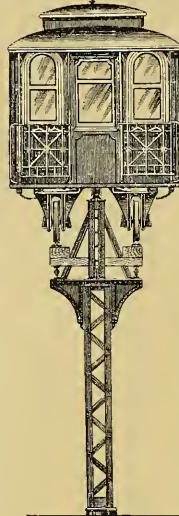

FIG. 2.

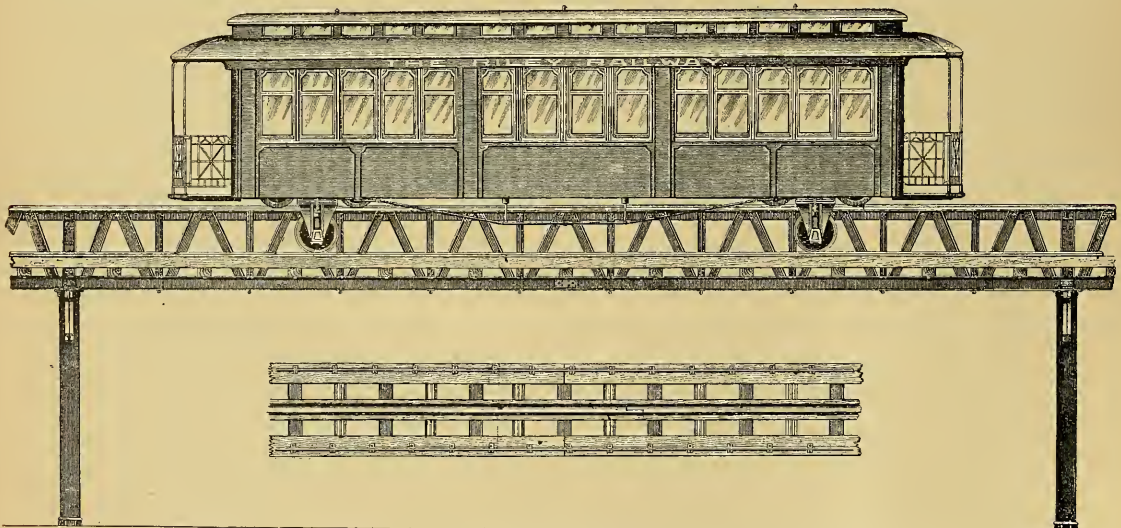

FIG. 1.

By bringing the car floor down to within four inches of the centre rail, the centre of gravity is lowered considerably. This reduces the height of stations and the number of steps thereto. As the car floor is lowered, the centre wheels must come up into the body of the car. The seats are arranged

Riley system. We may add that this new system has been critically examined by many of the ablest and most experienced civil and mechanical engineers of the country and has received their highest endorsement. It deserves the attention of those contemplating the construction of elevated roads.



**The Future of Electrical Transportation.**

It may not be inopportune to present here the views of a good contemporary on the absorbing question of electrical propulsion of street cars.

The application of electricity as a motive power for railroad trains, the earliest conception of which appears to be due to that eccentric genius, Henry Pinkus, "late of Pennsylvania, in the United States of America, gentleman," who flourished in London circa 1840, has apparently passed through its preliminary experimental period, says the *Electrician and Electrical Engineer*, as exemplified by the work of Siemens at Berlin, Edison at Menlo Park, Finney at Pittsburgh, and Field at Chicago, and has now reached the stage of a somewhat extended practical development. This era in the progress of the art may be said to have commenced with the Lichterfelde line of Siemens, opened May 16, 1881, which was followed by the Portrush line, September 30, 1882, and these two by many others, as given in Mr. Martin's table recently published. At the present

attempt to forecast some of the probabilities of the future development of electric transportation, in the light of what has already been accomplished.

In one field, that of surface street railroads, the universal employment of the electric motor is without doubt only a question of time, and not a very long time either. The practical success which has everywhere attended the introduction even of the comparatively crude methods and apparatus at present in use are sufficient evidence of the ultimate fulfillment of the prophecy. Even the ingenious and efficient, though expensive, cable system is certainly destined to follow the patient plodding horse into the limbo of superseded and obsolete street-car motors.

The next field to be occupied is that of the elevated and other city and suburban rapid transit passenger lines. This undertaking is a far more difficult one, but its accomplishment may, in our opinion, be looked for at no distant day. The conditions of the problem have been thoroughly mastered, the obstacles to be met with are sufficiently well appreciated and understood, and meanwhile several of the

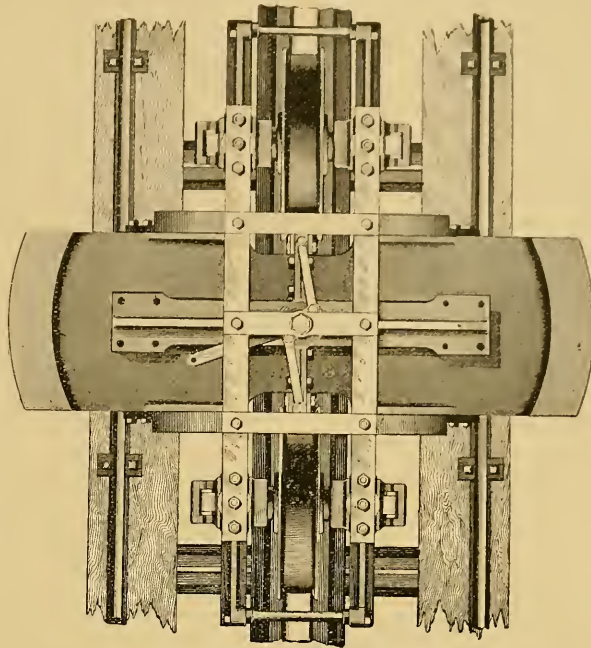

FIG. 4.—PLAN OF RILEY TRUCK.

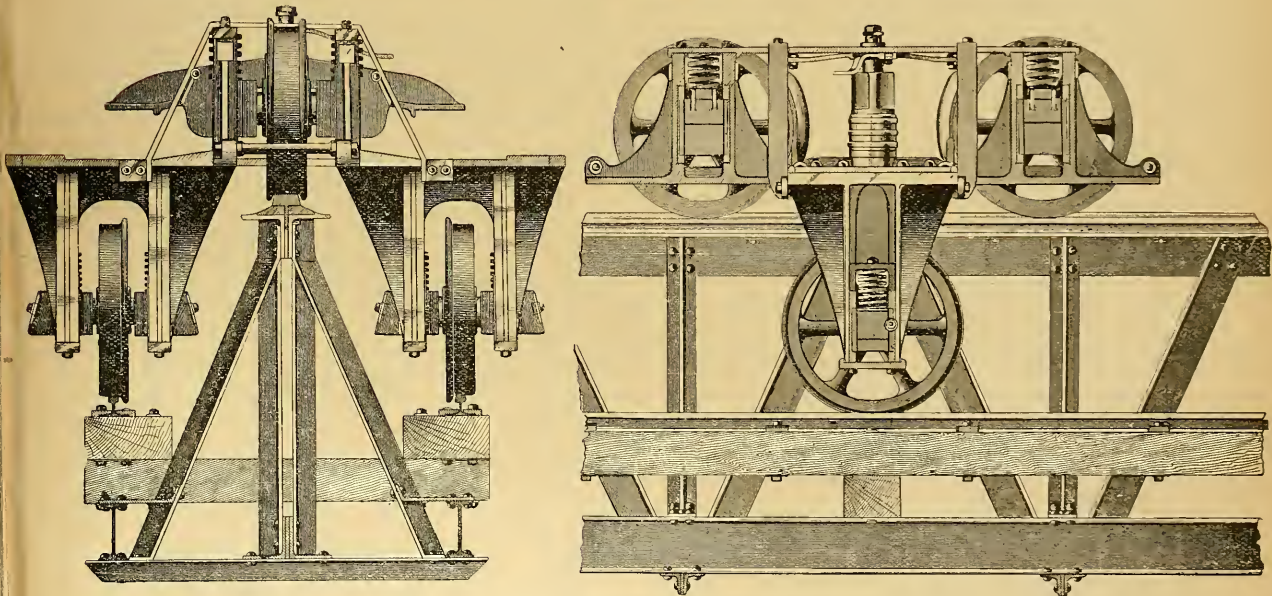

FIG. 3.—RILEY TRUCK (END AND SIDE ELEVATIONS).

moment a glance at the technical journals is sufficient to show that electric railroad enterprises are springing up like mushrooms in every direction, both in this country and abroad.

It may not be uninteresting at the present juncture to

ablest practical electricians of the day are devoting their best energies to the subject. No less than four electric locomotives designed for this class of service are under construction by different parties at the present time, and we



shall be much disappointed if one or more of them does not, upon trial, give sufficiently favorable results to render the future success of electric traction on railways of this class an assured success. The relief to the public in being freed from the annoyance of steam, smoke and cinders, and in great measure of noise as well, will be incalculable, while the probable resulting economy in operating expenses, although in our opinion considerably overestimated by sanguine inventors, will, nevertheless, be sufficient to render the change a profitable one to the owners of the roads.

### “Storage Batteries for Electric Locomotion.”

This was the subject of a special paper read by Professor Anthony Reckenzaun, electrician of the Electrical Accumulator company, at the sixth semi-annual convention of the National Electric Light association, held at Boston, August 9th, 10th and 11th. The essay itself is very interesting to those who keep their minds on the rapid progress made in the application of electricity to propel street cars, and especially to those who are anxiously waiting to see what will become of the storage battery system; and the discussion that followed the reading of the paper is most edifying. Prof. C. O. Mailloux (of the Julien Electric company) and the celebrated Dr. Otto Moses, and others, taking lively part therein.

The afternoon session of the third day of the convention was devoted to this subject. And we have much pleasure in extracting from a stenographic report of the proceedings all that may be of special interest to the readers of THE STREET RAILWAY GAZETTE. Mr. Mailloux first read a paper on

#### THE PRESENT STATUS OF THE STORAGE BATTERY.

“Only a year ago,” said he, “I would have hesitated, perhaps refused, to say anything before you in favor of the storage battery. My reason would not have been a lack of confidence, but rather a feeling that the era of the storage battery was not yet at hand. I felt that this youthful offspring of the great and powerful family of electrical applications promised to play as important an industrial role as any of its colleagues, but I also knew that it had already made one debut some years ago and failed to draw, because it was too young. I would have been sorry to see its chances of success forever spoiled by a second premature attempt. The child seems, however, to have now had sufficient time to mature and perfect its training, and after an interval of some five years it has reappeared upon the scene, this time with a fair and encouraging success. Within a few months there has been in America a great revival of interest in the storage battery, as you are aware. Many of us practical men, who were once disposed to be skeptical, begin to regain confidence. Certainly, the applications which have been made of the storage battery in this brief period prove beyond dispute that this time the storage battery is coming to stay. In some cases it found a new and profitable field waiting for it, as for instance in railroad car-lighting. In many other cases it opened an entirely new range of possibilities by its playing a secondary role. In a word it has a wide sphere of usefulness to cover, through many devious paths, some of which it alone can tread over, and many of which it will compass with the help of other applications of electricity. It does not presume to fill all these parts at once. In the case of some of them it may prove wise to permit the process of evolution to go on for some time to come before they are considered. \* \* \* The number of patents relating to storage batteries in this country and in Europe is already quite large, nevertheless the number of good storage batteries is exceedingly small. In this respect history repeats itself. The large and constantly increasing number of patents on dynamos, lamps, regulators, converters and what not, when contrasted with the small number of those inventions which are really useful, suggests that a large proportion of inventors must have been engaged too deeply in taking out patents, and pay altogether too little attention to reducing their inventions to practice.”

#### ELECTRIC RAILWAYS.

Mr. Mailloux's paper was confined to the storage battery in its application to electric lighting purposes. The discussion thereon was postponed until after the reading of Prof. Reckenzaun's paper on “storage batteries for electric locomotion.” Said he, “The idea of employing secondary batteries for propelling vehicles is almost contemporaneous with the discovery of this method of storing energy. To Mr. Planté, more than any other investigator, much of our knowledge in this branch of electrical science is due. He was the first to take advantage of the action of secondary currents in voltaic batteries. Planté is a scientist of the first grade, and he is a wonderfully exact experimenter. He examined the whole question of polarization of electrodes,\* using all kinds of metal as electrodes and many different liquids as electrolytes,† and during his endless researches he found that the greatest useful effect was produced when diluted sulphuric acid was electrolyzed between electrodes of metallic lead.

“A set of Planté original cells was exhibited for the first time, in March, 1860, before the Paris Academy of Sciences; scientists admired and praised it, but the general public knew nothing of the great discovery thus brought to notice. Indeed, at that period little commercial value could be attached to such apparatus, since the accumulator had to be charged by means of primary batteries, and it was then well known that electrical energy, when produced by chemical means in voltaic cells, was far too expensive for any purpose outside the physical laboratory or the telegraph office.

“It was twenty years after this exhibition at the Academy of Sciences in Paris, that public attention was drawn to the importance of storage batteries, and that Mr. Faure conceived the idea of constructing plates consisting of lead and oxides of lead. At that time the advantage accruing through a system of electrical storage could be fully appreciated, since electrical energy was already being produced by mechanical means through the medium of dynamo electric machines.

“It was the dynamo machine which created the demand for the storage battery, and the latter was introduced anew to the public at large and to the capitalist with great pomp and enthusiasm. One of Faure's accumulators was sent to Sir William Thompson, and this eminent scientist in the course of experiments ascertained that a single cell, weighing 165 lbs. can store two million foot pounds of energy, or one horse-power for one hour, and that the loss of energy in charging did not exceed 15 per cent. These results appeared highly encouraging, there we had a method of storing that could give out the greater part of the energy put in. The immense development which the electric transmission of energy was even at that early day expected to undergo pointed to the fact, that a convenient method of receiving large quantities of transmitted energy, and of holding it in readiness until wanted, must be of the highest importance. Numerous applications of the Faure battery were at once suggested, and the public jumped to the conclusion that a thing for which so many uses could be instantly found must necessarily be a profitable investment, and plenty of money was provided forthwith, not with the idea of commencing careful experiments, and developing the then crude invention, which would have been the correct thing, but for manufacturing tons of accumulators in their first and immature form.

“I need not describe the disappointments which followed the first unfulfilled hopes, nor repeat the criticism that was heaped upon the heads of the early promoters. Those early hopes were untimely and unreasonable. A thousand difficulties had to be overcome, scientific difficulties and manufacturing difficulties. This invention, like most others, had to go through steady historical developments and evolution, and follow the recognized laws of nature which are against abnormal and instantaneous maturity. The period of maturity has also been retarded by injudicious treat-

\*The so-called poles of the voltaic circle; or, paths for electricity.

†Liquid compounds decomposable, or subjected to decomposition, by an electric current.



ment, but the ultimate success was inevitable. Great advances have been made within the last few years, and I propose now to offer a few facts and figures relating to the present state of the subject with reference to the application of storage batteries to locomotive purposes. It is not within the province of this paper to discuss all the different inventions of secondary batteries nor to offer any suggestions with regard to priority, therefore I will confine myself to general statements. I am aware of the good work that was done in the United States by Kirchoff, twenty-six years ago, and of the more recent work of Mr. Brush, of Cleveland, Mr. Julien and others, but I am more particularly acquainted with the achievements of the New York Accumulator company, who own the rights of the Electrical Power Storage company, of London. I have used the batteries of the latter company for propelling electric boats and electric street cars. The first of the boats was the 'Electricity,' which was launched in September, 1882, and which attained a speed of seven miles an hour for six consecutive hours. Since then a dozen electric boats of various sizes have been fitted up and worked successfully by means of storage batteries and motors of my design. The most important of these were the launch 'Volta,' and another similar craft, which is used by the Italian government for torpedo work in the harbor of Spezzia. In the measured mile trial trips the Italian launch gave an average speed of 8.43 miles an hour with and against the tide. The hull of this vessel was built by Messrs. Yarrow & Co., and the motors were manufactured by Messrs. Stephens, Smith & Co., of London. The 'Volta,' which was entirely fitted by the latter firm, is 37 feet long and 7 feet beam, she draws 2 ft. 6 in. of water when carrying forty persons, for whom there is ample sitting accommodation. There are sixty-four cells in this boat, these are placed as ballasts under the floor, and actuate a pair of motors and a screw coupled direct to the armature shaft running at 700 revolutions a minute. We crossed the English channel with this boat in September of last year, leaving Dover at 2:40 in the morning, arrived at Calais at 2:30 p. m., stayed about an hour in the French harbor for luncheon, and floated into Dover docks the same evening at 6:30, at full speed. The actual distance traversed without entirely discharging the cells was fifty-four miles, the current remained constant at 28 ampères until 5 p. m., and it only dropped at 25 ampères at the completion of the double voyage between England and France. Several electric launches are now being constructed in London, and one in New York by the Electrical Accumulator company.

"M. Trouvé exhibited a small boat and a tricycle, both worked by Planté accumulators, at Paris, in 1881. The first locomotive actuated by storage batteries was used at a bleaching works in France in 1882.

"During the same year I designed an electric street car for the Storage company, and this was tried on the lines of the West Metropolitan tramways in March, 1883. It had accommodation for 46 passengers. This car had many defects, and I reconstructed it entirely, and ran it afterwards in its improved form on the South London tramways, and also on a private track at Millwall, where it is now in good condition, and I have a similar car in Berlin. M. Phillippart exhibited a car in Paris and M. Julien made successful experiments in Brussels, Antwerp and Hamburg. Mr. Eliason is running storage battery locomotives in London. Mr. Julien has also been experimenting with a car in New York, and I believe one is in course of construction for a line in the city of Boston. Messrs. W. Wharton, jr. & Co., have a storage battery car running at Philadelphia on Spruce and Pine streets, and this energetic firm is now fitting up another car with two trucks, each carrying an independent motor, similar to my European cars.

"I have mentioned all these facts in order to show that there is a considerable amount of activity displayed in the matter of storage batteries for street cars, and that continued and substantial progress is being made in each successive case. The prejudices against the application of secondary batteries are being rapidly dispelled, and there are indications everywhere that this method of propulsion will soon take a recognized place among the great transit facilities in

the United States. I feel confident that this country will also in this respect be far ahead of Europe before another year has passed over our heads.

#### THE OBJECTIONS.

"There are several popular, and I may say, serious objections to the employment of storage batteries for propelling street cars; these objections I will now enumerate and endeavor to show how far they are true, and in what measure they interfere with the economical side of the question.

"First objection: The loss of energy, which amounts in practice to 20, and sometimes 30 per cent. Now, every method of storing or transmitting energy involves some waste, but in saying this we need not condemn the system, for after all the term efficiency is only a relative one. For instance, a 10 horse power steam engine consumes three times as much fuel per horse power per hour as a 1,000 horse power engine does, yet this small engine must be, and is regarded as one of the most economical labor-saving appliances known to us. Considered as a heat engine the efficiency of the most economical steam motor is but 10 per cent—90 per cent of the available units of heat contained in coal being lost during its transformation into mechanical energy. Thus if we find that the storage battery does not return more than 70 per cent of the work expended in charging it, we ought not to condemn it on that account until we have ascertained whether this efficiency renders the system unfit for any or all commercial purposes. It is needless to go into figures in order to show that, when compared with animal power, this objection drops into insignificance.

"The second, and more formidable objection, relates to the weight of storage batteries—and this involves two disadvantages, viz., waste of power in propelling the accumulator along with the car, and increased pressure upon the street rails, which are only fitted to carry a maximum of five tons distributed over four points, so that each wheel of an ordinary car produces a pressure  $1\frac{1}{4}$  tons upon a point of the rail immediately under it.

"The last-mentioned objection is easily overcome by distributing the weight of the car with its electrical apparatus over eight wheels or two small trucks, whereby the pressure per unit of section on the rails is reduced to a minimum. With regard to the weight of the storage batteries, relatively to the amount of energy the same are capable of holding and transmitting, I beg to offer a few practical figures. Theoretically, the energy manifested in the separation of one pound of lead from its oxide, is equivalent to 360,000 foot pounds, but these chemical equivalents, though interesting in themselves, give us no tangible idea of the actual capacity of a battery.

"Repeated experiments have shown me that the capacity of a secondary battery cell varies with the rate at which it is charged and discharged. For instance, a cell, such as we use on street cars, gave a useful capacity of 137.3 ampère hours when discharged at the average rate of 45.76 ampères, and this same cell yielded 156.38 ampère hours when worked at the rate of 22.34 ampères.\* At the commencement of the discharge the e. m. f. (electro-motive force) of the battery was 2.1 volts† and this was allowed to drop to 1.87 volts when the experiment was concluded. The entire active material contained in the plates of one cell weighed 11.5 lbs., therefore the energy given off per pound of active substance at the above high rate of discharge was 62,225 foot pounds, and when discharging at the lower rate of 22.34 ampères the available useful energy was 72,313 foot pounds, or nearly 2.2 electrical horse power per pound of active matter. But this active substance has to be supported, and the strength or weight of the support has to be made sufficiently great to give the plate a definite strength and durability. The support of the plates inclusive of the terminals above referred to weighs more than the active material which consists of peroxide of lead and spongy lead so that

\*An ampère is the unit of current strength; it may be compared to the flow of water through a pipe.

†A volt is the unit of electro-motive force, which is akin to the pressure in a steam boiler.

the plates of one cell weigh actually 26.5 lbs; add to this the weight of the receptacle and acid, and you get a total of about 41 lbs. per cell when in working order. Seventy of these cells will propel an ordinary street car for four hours and a half while consuming the stored energy at the rate of 30 amperes, or over 5.6 electrical horse power. The whole set of 70 cells weighs 2870 lbs., which is barely one-fifth of the entire weight of the car when it carries 40 adult passengers, therefore the energy wasted in propelling the accumulator along with a car does not amount to more than 20 per cent. of the total power, and this we can easily afford to lose so long as animal power is our only competition. From numerous and exhaustive tests with accumulator cars in this country and abroad I have come to the conclusion that the motive power for hauling a full-sized street car for 15 hours a day does not exceed \$1.75, and this includes fuel, water, oil, attendance and repairs to engine, boiler and dynamo. We have thus an immense margin left between the cost of electric traction and horse traction, and the last objection, that relating to the depreciation of the battery plates, can be most liberally met and yet leave ample profits over the old method of propulsion by means of animals.

"The advantages of storage battery street cars for city traffic are self-evident, so that I need not trouble you with further details in this respect, but I would beg those who take an interest in the progress of electric locomotives to give this subject all the consideration it deserves, and I would assure them that the system which I have advocated in this brief but very incomplete sketch is worthy of an extended trial, and ready for the purposes set forth. There is no reason why those connected with electric lighting interests in the various cities and towns should not give the matter their special attention, as they are best informed on electrical engineering and already have a local control of the supply of current needed for charging."

Dr. Moses asked Prof. Reckenzaun to "give us the weight in pounds of the car that he speaks of in Philadelphia, and which he wants us to go and ride upon." He was also asked, (1) "What time does it take to change your battery?" (2) "What loss of energy have you found accompanies the moving of the batteries from the car to the depository where they are charged?" (3) "What is the loss of energy per diem by allowing the batteries to remain unused?" And (4) by Mr. Powers, "When it requires from four to twelve horse power to accomplish this work, I would like to know where the loss occurs — if the energy of the street car horse is good for two to six horse power?"

In reply Prof. Reckenzaun said:

"I have given the weight of the batteries in this paper. In the car which we use in Philadelphia, there are actually 80 cells, because there are considerable gradients to go over. Each cell weighs 40 pounds and the average horse power each is six. Sometimes we only use two horse power and sometimes, going up grades of five per cent., we use as much as twelve horse power, but the average rate is six electrical horse power. With reference to the weight of passengers on the cars, we have never carried more than 50 passengers on that car, because it is impossible to put more than 50 men into it. There are seats for 24 and the rest have to stand on the platform and along the step.

"The changing of the batteries takes three minutes with proper appliances. One set of cells is drawn out by means of a small winch and a freshly charged set is put in. It takes the same time to charge the battery as it does to discharge it in the working of the cars, so one reserve set would be sufficient to keep the car continually moving. The car is pushed into the depot where the cells are being charged. Therefore, there is no moving of the cells required with the exception of just taking them out of the car and pushing a fresh lot in and one powerful man can tend to that.

"The loss of energy from standing about is probably nothing. If a battery were to stand charged for eight months in a dry case the loss of energy might be in three months 10 per cent. I purposely had a set of cells standing for two years charged and never used them. After two years there was still a small amount of energy left. So as regards the loss of energy in a battery standing idle it is

practically nothing, because no one would think of charging a battery and letting it stand for three months or a year."

In answer to Mr. Powers' question the professor said he had made experiments in London with a loaded car pulled by two horses. "I put a dynamo meter between the attachment of the horse and the car, so as to ascertain exactly the pulling, measured in pounds multiplied by the distance traversed in a minute. You will be surprised to know that two horses, when doing their easiest work, drawing a loaded car on a perfectly level road, exert from two to three horse power. I have mentioned a car in Philadelphia where we use between two and twelve horse power. Each horse is capable of exerting eight horse power for a few minutes, and when a car is being driven up a grade, the same as I see in Boston for instance, pulling a load of passengers up these grades, those two horses are exerting from twelve to sixteen mechanical horse power. That is the reason that street car horses can not be run more than three or four hours out of the twenty-four. If they are run longer they would be dead in a few weeks. If they run two hours a day they will last three or four years. That is 33,000 foot pounds per minute per horse power."

An interesting statement was made in reply to Mr. Phelps' query as to

#### THE LIFE OF THE CELLS.

Prof. Reckenzaun said: "An estimate of the life of the cells, if expressed in pounds, amounts to nothing at all. The life of the cells must be expressed upon the principle of ampere hours or the amount of energy given off through them. Street car work requires that the cells work their hardest from fifteen to sixteen hours per day. The life of the cells is to be divided first into the life of the box which contains the plates. This box, if appropriately constructed, will last many years, because there is no actual wear on it. The life of the negative plates will be considerable because no chemical action is going on in the negative plate. The negative plate consists almost entirely of sponge lead and the hydrogen is mechanically occluded from that sponge lead. Therefore the depreciation of the battery is entirely due to the peroxidation of the positive plates. If we should make a lead battery of plates one-quarter of an inch thick, it would last many years; but for street car work that would be far too heavy. Therefore we make the positive plates a little more than one-eighth of an inch thick. I find that the plates get sufficiently brittle to almost fall to pieces after the car has run daily fifteen hours a day for six months. The plates then have to be renewed. But this renewal does not mean throwing away entirely all the plates. The weight is the same as before, because no consumption of material takes place. We take out peroxide of lead instead of red lead. That peroxide if converted into metallic lead produces 70 per cent. of metallic lead, so that there is a loss of 30 per cent. in value. Then comes the question of the manufacture of these positive plates, which, I believe, at the present day is rather expensive, about eight cents a plate for the labor only. But I believe, the time will come when battery plates will be manufactured like shoe nails and the process of renewing the positive plates will be very cheap one."

Mr. J. B. Martin asked if the loss in getting the current into the storage battery, and then delivering it to the motor is less in comparison than that in the use of the cable in the power finally delivered to the car, in the cable system of propelling street cars?

#### THE VARIOUS SYSTEMS COMPARED.

The professor answered: "I have made some very careful observations of the cable tramway in Philadelphia, which is quite an extensive system. I have never been able to ascertain the exact amount of waste in pulling the cable itself. But I have it on the authority of certain technical papers that there is a waste of about eighty per cent. I do not intend to depreciate cable or any other tramways, but there is a difficulty about introducing cable tramways. It is necessary to dig up the streets and interfere with the roadways. I have been told that the cable arrangements in Philadelphia cost \$100,000 a mile, and that the cable road in San Francisco cost more than that. One of the directors of



the cable company in Philadelphia told me that if he had seen the battery system before the introduction of the cable he would probably have made up his mind in favor of it.

"The wear and tear in the case of the storage system is also considerable. There is a waste of energy in the dynamo; secondly, in the accumulator charged by that dynamo; thirdly, in the motor which is driven by the accumulator; and fourthly, in the gearing which reduces the speed of the motor to the speed required by the car axles, because it would be difficult to make a motor run at the rate of eighty revolutions to the minute, which is the number of revolutions on the street car axle when running at the rate of ten miles an hour. Take all these wastes and you find in practice that you do not get more than forty per cent. of the energy given by the steam engine on the car axles. But this is quite sufficient to make this system much cheaper than horse traction."

### Electric Motor Exhibition.

There was also an exhibition of an electric motor at Philadelphia recently which attracted much attention. Our Boston representative says that President Richards and others in that city have taken great interest therein. Among those who witnessed the exhibition were the president and a committee of directors of the Brooklyn City Railway, Brooklyn, N. Y.; the president of the Norristown Street Passenger Railway, the president of the Chester Street Railway, of Chester, Pa.; Alexander M. Fox, President of the Second and Third Streets Railway; John Noblit, President of the Frankford and Southwark City Railway company; John B. Parsons, President of the People's Line, and representatives of other lines in Philadelphia, and other cities.

The car was the same as the one used in the former exhibitions, the changes being slight and in details only. In this car the storage batteries, eighty-four in number, are placed beneath the seats, and the electric energy generated is conducted to a switch-box on the front platform, so arranged that the driver may utilize more or less of the power as becomes necessary. From the switch-box the current is conveyed to a Sprague electric motor, beneath the floor of the car, which is geared directly with a toothed wheel on the front axle of the car. One change has been made in the commutator or switch-box, by which the forward or backward motion is regulated by a second and separate handle, the motor being permanently arranged to go ahead, except in emergencies, when the throwing over of the second handle arranges it to run backward. It was stated that it is rarely required to run a street car backward, and the control of both the forward and back movement by a single handle is liable to confuse an inexperienced driver. A mechanical brake has also been added to the car.

Leaving the yard of the Wharton Switch Company, at Twenty-third and Washington avenue, where the car is housed and where the experiments upon it have been made, the motor ran out on Twenty-third street up to Spruce, etc., and returned to the works. After Mr. Wharton had made some remarks upon the subject of driving street cars by electricity, and Prof. Reckenzaun, electrician of the Electrical Accumulator company, had given some facts concerning storage batteries, a second trip to the Exchange and back was made without recharging the batteries. Both trips were completely successful, and no difficulties whatever in running or controlling the car were encountered.

In the course of his remarks Mr. Wharton said that railway companies were becoming more and more convinced every year that electricity was destined to replace horses on street railways, and the great question was the method in which it should be used. A body of capitalists, not committed to any particular invention, had investigated the subject and believed that they had established several important points. There were four principal methods of propelling street cars by electricity—by overhead conductors, underground conductors, surface conductors and storage batteries. All three of the first-mentioned systems had objections which seemed to them vital. In cities of large size overhead conductors could not be tolerated, surface conductors

were dangerous, and underground conductors possessed no real advantage over the cable railway system, and in many respects were inferior to it. All were rendered almost useless by ice and snow, and, even were they freed from these and other objections, they had one defect which applies equally to the cable system, that if any part of the line became defective, if the machinery got out of order, or if a fire should block travel, the whole system must come to a stop. They therefore directed their attention to storage batteries, and believed that they had at last procured a system much cheaper and better than horses, perfectly under control, not liable to serious interruption from accidents, and whose disadvantages were trifling compared to its usefulness. He did not believe that it was destined to supplant all other forms of motors. Where steam locomotives could be used the electric motor had no place. So, too, where the gradients were excessive, as in the cities of Cincinnati and San Francisco, the cable system was the best that could be used, but as a substitute for horse power he knew of nothing which would compare to stored electricity.

The present car was only an experimental one, in which they had studied the weak points of the system and had succeeded in remedying them. The car used was only an old horse car, which had been fitted up for the purpose of experimentation, but they had succeeded in demonstrating upon it the feasibility and cheapness of the system. They had shown that a street car could be driven by stored electricity at a cost very much lower than that of horses for the same service. The batteries were stored by a small gas engine, which is a very costly method of generating power compared with a large steam engine; they then expended their energy on a motor not specially constructed for the purpose, which was used to drive a car not adapted to develop the best results, yet even with this imperfect apparatus, they were able to show a large saving over horses. During the past month the car had been used almost daily, frequently upon extended trips, but the bill for gas consumed in generating power amounted to only \$27.

They were now about building a special car, the plans of which are already drawn, to be one-third larger than the ordinary street car, and to be supported on eight wheels divided between two trucks. Two motors, designed by Prof. Anthony Reckenzaun for the purpose, are on their way, which will be used on this car, and everything about it will be especially contrived to adapt it to this form of propulsion.

When this car was finished, which he expected would be in about one month, they would be prepared to manufacture duplicates, to introduce a few of them upon such railways as would be willing to make the experiment, and, if successful, to enter into contracts to completely furnish lines with electric motor cars. Until then he asked the gentlemen present to suspend the adoption of any other system upon their respective lines, and having tried the various systems to give their contracts to whichever one showed the best results. The gentlemen interested in this system did not desire outside aid to develop it. They would merely offer the result of their experimentation to the consideration of railway men and fit up roads on a business basis.

Prof. Anthony Reckenzaun made a few remarks on storage batteries. He said that the only vital question concerning them was as to the rapidity of deterioration. He here stated some of the facts contained in his paper on electric propulsion, which we give in another column.

Mr. Wharton stated that the Emperor of Brazil has sent an order for a special palace car for his own private use, to run upon the street railway lines of Rio de Janeiro, and that it was understood that the car was to be run by Sprague's motors, driven by the storage batteries of the Electrical Accumulator company. He said that it was a curious commentary upon the widespread knowledge of the present day that the first electrical storage car of this system in practical service would run upon the tracks of a street railway in South America.

HORSE forms part of the incorporated name of the "Derby Horse Railway Co.," Ansonia, Connecticut, although it is operated by Van Depoele's electric motors.

# The Street Railway Gazette.

Annual Subscription (Including Postage).		Per Copy.
United States, Canada .....	\$2.00.	30c.
Great Britain, Ireland, India, Australia.....	10s.	11d.
Germany.....	9mk. 75 pf.	89pf.
France, Belgium, Switzerland.....	1fr. 95c.	Fr.1.10.
Spain.....	11ps. 95c.	Ps 1.10.
Austria, Holland.....	5fl. 74c.	53c.
Italy.....	12 lire.	1¼ lra.
Venezuela.....	12 bolivars.	1¼ bol.
Mexico.....	\$2.96.	30c.
<i>Ann. Subs. in Argentine Republic, 2½ pesos; Brazil, 4 milreits; Turkey, 54 piasters</i>		

Registered Cable Address=TRAM, CHICAGO.

**PUBLISHERS:**  
**THE WRIGHT-MONROE COMPANY.**

P. G. Monroe, - - - - - President.  
 E. V. Cavell, - - - - - Secretary.  
 S. L. K. Monroe, - - - - - Treasurer.

**GENERAL OFFICES:**

CHICAGO, - - - - - NEW YORK, - - - - - BOSTON.

[CHICAGO,  
 9 LAKESIDE BUILDING.

P. G. Monroe, - - - - - General Manager.  
 William Hughes, - - - - - Editor.  
 Edward J. Lawless, - - - - - Associate Editor.

NEW YORK:  
 181 BROADWAY.

Henry C. Lockwood, - - - - - Resident Editor and Manager.

BOSTON:  
 19 TREMONT ROW.

T. P. Pemberton, - - - - - Resident Editor and Manager.

**EUROPEAN OFFICE:**

LONDON: W. S. G. Baker, Jr., (care Brown, Shipley & Co.), Res. Mgr.

**BRANCH OFFICES:**

ATLANTA, Ga.: Chamber of Commerce Bldg., Wm. Minnigerode, Mgr.  
 SAN FRANCISCO, Cal; 1222 Bush St.,—O. W. Fairchild, Manager.

**CANADIAN AGENCY:**

TORONTO: 53 Magill Street,—Thomas Henry, Manager.

“ENOUGH has been said to indicate” that the storage battery system may ere long be perfected; and if it falls through it will be very disappointing to many, for not a few have put their faith therein—although the leading electricians have not yet completed their experiments.

PRINTERS' ink has been used pretty freely by the Knights of Labor, and the labor organs and handbills, short-sighted as they always are, have proved of immense advantage to them. This source of influence was turned against them by the well-known firm of John Stephenson company, street car builders, New York, during a recent strike at their works. No sooner had some of their late workmen declared themselves out on strike than the firm had the conspiracy section of the penal code printed in circular form and distributed among their rebellious hands, which had a wonderful effect.

CABLE propulsion, as strikingly shown in our special correspondence from St. Louis, is still an active rival to electricity. Indeed electricians admit that the Hallidie cable (or wire-rope) is preferable in some districts. And not only is the admirable California system making rapid headway; but the Rasmussen cable railway is also coming to stay. A contract was closed to build a line at Sioux City, Iowa, on the latter system, soon after the experiments were opened at the west end of Lake street, Chicago; and now we have to record a contract to convert the Newark and Irvington (New Jersey) horse railway into a Rasmussen cable line, with a prospect of its adoption on the New York Belt line.

“PRACTICAL Devices useful in the Economical Management of Street Railways” is the subject assigned for Mr. DeWitt C. Cregier, Supt. of the Chicago West Div. Ry. Co., to read a paper on at the forthcoming Street Railway Convention at Philadelphia (commencing Oct. 19). We regret to learn that Mr. Cregier has written to the Secretary of the Association to the effect that he cannot find time to do justice to the subject and desires the substitution of some one else. “Devices” for the management of street railways are numerous enough; many of them are practical, while several are useful, and some are economical. Mr. Cregier has been unusually busy of late; and although he has obtained patents for improvements in street railway appliances himself, he requires further acquaintance with many devices used in different parts of the country to enable him to write such a paper as would be satisfactory to himself and others.

“ELECTRICITY as a Motive Power” is one of the principal subjects of special papers to come before the Philadelphia Convention. Indeed we may well say it is the “burning question;” and it is in good hands. Mr. William Wharton, jr.,—who is to prepare the paper—has been experimenting considerably himself. As appears from a report of the electric motor exhibition under Mr. Wharton's superintendence, in another part of this issue of the GAZETTE, he favors the storage battery system. But for all that he is open to reconviction in favor of anything he may find better. We do not know what a day may bring forth. And as we have stated in previous issues, there is a general expectancy for something to turn up—surpassing anything yet achieved—in the way of electrical locomotion. We are glad to learn that Mr. Wharton's mind is in a thoroughly receptive mood for any further developments. In reply to an enquiry we took the liberty of addressing him, he says (Sept. 10): “I have not yet written the paper alluded to, and I do not intend to until immediately before the meeting of the Convention, as I wish to embody in it any improvements or changes which might take place up to the very time of the meeting. As you know, the subject is one in which there is a great advance being made almost from day to day.”

“MANY an inventor, and many a person who has invested in patent rights, can testify that an idea has seemed practical up to the last moment before its introduction to the public, and then has fallen flat over some unforeseen difficulty.” On the other hand, many an inventor has groped in the dark, and labored at experiments with the hope of bringing a “cute idea into practice, and felt a degree of uncertainty until the last moment; and behold he succeeds beyond his expectations. Many of the most useful inventions have been discovered in the latter way; and when we hear or read of professors of electricity expressing unbounded certainty as to the future development of an electric appliance we cannot help feeling dubious. In this month's GAZETTE we give a good and edifying collection of the views of some of the chief electricians of the day as regards the storage battery method of propelling street cars. That system is yet in the experimental stage. And that is the case particularly with regard to the Baltimore “combination” plan; but *The Ries Electric Railway System*, referring to the extracts from their pamphlet in our last issue, say: “The very generous extracts you make may at present appear slightly visionary, but every one of them is capable of fulfillment, as we shall shortly endeavor to demonstrate. We have been working quietly and without ostentation, but with considerable perseverance and energy, toward the development of a complete and practical system of electric railways and for the most part have not hesitated to leave beaten paths and turn our attention in new directions whenever these promised to give better or more practical results. We hope shortly to have our system so far perfected theoretically as to warrant us in commencing its practical demonstration and introduction.” The Weis storage battery test, according to our report thereof on opposite page, seems to have advanced a few steps beyond the rest, and much may be expected therefrom in the immediate future.



## Another Storage Battery Test.

### THE WEIS SYSTEM.

We are assured, by a reliable party who witnessed the experiment, that the storage battery problem, in its application to propel street cars, has been thoroughly solved and practically demonstrated at last. At all events the special report we have received says that much has been done toward making it a practical success.

The new motor and mechanical arrangement, designed by Mr. T. J. Weis (train dispatcher in the employ of the Penn. R. R. Co.), was tested on Friday night, Sept. 2, before a number of spectators, including Messrs. Wm. Ettinger, electrician, Penna. R. R.; A. Jackson, of the Electrical Accumulator Co., of N. Y.; G. B. Caldwell, pres. Citizens Ry. Co., Wheeling, W. Va.; C. J. McConaughy, train dispatcher, Penna. R. R.; E. V. Cavell, of Chicago, secretary STREET RAILWAY GAZETTE; Messrs. G. J. Sullivan, T. Bradley and others. The Jersey City and Bergen H. R. R. Co., placed its tracks at the disposal of Mr. Weis, and had one of its cars equipped with the device. Upon entering the car, which was lighted by 3 16 c. p. incandescent lights, Mr. Weis had a section of the floor taken up to permit a close inspection of the location of the 5 hp. motor (weighing 400 lbs.), etc.; this being done a seat was removed to show the location of the batteries (of the Julien type, arranged in series of 22, 32 and 40 cells, each cell weighing 35 lbs.) which had been placed thereunder.

A start was made, and the inertia overcome (total weight of car and equipment being a trifle over 6,000 lbs.) without difficulty, and the run was continued, at speeds varying from 6 to 20 miles per hour, up grades of over 4 %, and around several awkward short curves of a mean radius of 27'. The switch was turned to 32 cells at starting, but quickly changed to 22, which amount of power proved ample to propel the car at a speed equal or in excess of that attempted by any cable line yet in operation. Occasionally some one would ring the bell, and the car was stopped without jerk or jar within about its own length; quick stops were also made on both grades and curves, and in no case was there any apparent difficulty. It is a noteworthy fact that although the battery consisted of 40 cells, at no time, even when running at from 15 to 20 m. per hour, was it found necessary to call over 32 into requisition—not even in starting midway up a grade of from 4 to 5 %, where the amount of power required to overcome the inertia is greatly increased, which fact cannot but speak well for the economy of the device.

From a record of tests, covering a period of several weeks, it looks as though a single charging of the battery will yield an equivalent of from 10 to 12 hours of service as usually performed by street car horses, and so on.

A pleasing feature was the ease with which the car was controlled, the application of the motive power by means of the friction wheels direct upon the driving-wheels producing the motion, being such that neither jar nor jerk were perceptible, either when starting or stopping, or when suddenly increasing the speed by switching on power from another ten cells. In pleasing contrast to the usual "buzzing" or "whirring" noise, often objected to in the operation of various electric systems, was the perfect quiet with which the driving arrangement worked; not a sound being heard but that occasioned by the car running over the rails. Those who witnessed the trial, while admitting that there is always room for improvement, returned to the Astor House, at 5 a. m., convinced that, in his invention, Mr. Weis has done much to make electric traction by means of storage batteries a practical success, at least so far as a satisfactory speed, easy manipulation, and economical service go.

## New York Elevated Railway Fares.

The recent depreciation of the stock of the New York elevated railways again brings up the question of the restoration of the ten-cent fare on the Sixth and Third avenue roads, outside of commission hours. Some advocate this "restoration" plan. On the other hand it is urged that the fall of ten points was due to speculation. In this connection

it is interesting to review the list of securities which the elevated roads are expected to pay interest on:

Manhattan consolidated stock .....	\$24,395,700
Metropolitan first mortgage bonds .....	10,818,000
Metropolitan second mortgage bonds .....	4,000,000
N. Y. Elevated first mortgage .....	8,500,000
Debentures .....	1,000,000

Total .....

\$48,713,700

Another reason given for the proposed change is to induce people to ride on the Second and Ninth avenue roads, where rates will remain at five cents at all hours, and thus relieve the pressure of travel on the more popular roads.

## Special Correspondence.

ST. LOUIS, Mo., August 30, 1887.

The agitation of the rapid transit question in this city is beginning to bear fruit, and there is promise of a rich harvest. The associated street railway companies have been experimenting for several years with various systems of foreign and local inventions. They have hesitated about putting in the cable because they believed that electricity would ultimately solve the transit question. Three years ago John H. Maxon, then President of the Lindell Railway Co., and Julius S. Walsh, President of the Citizens' Railway Co., both told me that if they had cable plants lying beside their tracks ready to put down they would sell them for old iron rather than use them. Mr. Walsh's ideas have undergone a decided revolution, for the cable will probably be in operation on Franklin avenue by the end of September. The Lindell road, however, is still experimenting with the electric motor. The Julien motor and the Julien storage battery were used on one of the cars of the road for quite a time. Just before Mr. Maxon's resignation from the board of directors the principal stockholders were taken on a trial trip over the road on the motor car. The experiment met with their approval, and they authorized Capt. Robert McCulloch, the new President of the company, to obtain one of the Brush motors from Cleveland and a Sprague motor from New York to continue the experiments. It was confidently expected that these two motors would be in operation this month, but there have been several delays and the prospects now are that it will be well into September before all the motors are at work. The Brush motor was shipped from Cleveland, according to advices received here, on August 20, but it has not arrived here yet. The construction of the Sprague motor is delayed by the sickness of Mr. Sprague. The cells for the storage batteries arrived several weeks ago and are now at the company's car sheds. Connection has been established with an electric supply house on Seventh and Walnut streets, and everything is in readiness to proceed with the experiments when the motors arrive. Capt. McCulloch is now looking out for a storage battery which will be as satisfactory as the Julien and less expensive. He says the Julien motor gives satisfaction, but its cost is a great objection.

Within the past week the Lindell road has made a change in its schedule, which has increased its business considerably. One-horse cars have always been used on the extension from Grand avenue to Vandeventer avenue. Under the new order of things the double cars make the trip over the extension to Vandeventer avenue during two hours every morning and two hours every evening. The business of the road has increased materially since the change was made, as there was a strong prejudice against the "bob-tails."

The cable division of the Cable and Western road has been shut down for two days, the stoppage being made to permit some changes at the power-house. The drums which were put in when the road was constructed were found to be too light. Since the addition of the double-deckers to the road's equipment the strain on the cable has been enormous. At six o'clock in the evening there is frequently a strain of 600,000 pounds on the rope. The strain was too much for the drums, and the cables slipped a great deal. This was damaging the cable wire at a rapid rate.

A new cable was put in a few weeks ago, and the road has suspended business three times since for repairs to it. At one time a new piece of rope 200 feet in length had to be spliced in. Besides, the drums were found to be cracked in two places at their hubs. So new drums, somewhat heavier than the old, have been put in place. It is doubtful if this road will ever be a mechanical success until the cable is divided. Two cables, one running east and the other west of the power-house, would divide the work very nicely. General Manager De Figueiredo has done much to perfect the mechanical action of the road since he took charge, but he is working against pretty big odds just now. Recently he appointed two superintendents to divide the detail work with him. M. S. Shipley, superintendent of the cable division, began working for the road at the time of its construction, and has worked his way up. T. S. McDonald, superintendent of the steam division, was at one time assistant superintendent of the Missouri, Kansas and Texas road.

The Cable and Western Co. has gone very heavily into one of the Pain pyrotechnic exhibitions. Pain's representative was looking about for a suitable location for "The Last Days of Pompeii," one of his finest spectacles, when some one suggested a location on the cable company's narrow gauge road. The St. Louis management of the road, backed up by Boston capital, took hold of the thing with energy, and already contracts have been entered into for the expenditure of more than \$40,000. The track has been doubled to King's Highway, a distance of two and a quarter miles. A large strip of property near King's Highway has been leased, and a larger strip purchased. A Y is being run from the main line, platforms built, a stand costing more than \$7,000 erected, a lake constructed, and the equipment of the road increased by the addition of a number of summer steam cars. In order to double the track of the road it was necessary to make the street crossings at night. A force of men was set at work shortly after midnight Sunday morning, and the crossings were all made in three hours without molestation by the police. The property holders raised strong objections, and the city council brought suit for injunction against the road. The cable people claimed the right to cross the streets under an old ordinance. A compromise was finally effected, the cable company agreeing to abide by the decision of the Municipal Assembly at its next session. The assembly is now in special session, but it will not take up the cable question until its regular session in November. The pyrotechnic exhibition will open September 14th. President Tredway has written the Mayor, extending an invitation to the President of the United States and his party to visit the show October 3, when he proposes to display a large pyrotechnic picture of Mr. and Mrs. Cleveland.

General Manager De Figueiredo is now working on a plan for the illumination of the entire route of the cable line by electric lights placed at intervals of one block.

Work on the Franklin avenue and Morgan street cable is progressing rapidly. The contractors are under bond to complete the road by September 15th, and they expect to have it done by that time. It will be in operation October 1st. The contractors put on a double force of men two weeks ago to expedite the work. The crossing of the two cables at Franklin and Garrison avenues was partly made during the stoppage of the Cable and Western two days ago. Another crossing is still to be laid. The big pits are completed, and the power-house will receive the finishing touches this week. Workmen are now engaged in putting in the big engines, the foundations for which were completed last week. The tunnel running from Grand and Cass avenues to the power-house has been completed. It will be illuminated by electric light. A two-story car shed, 396x200 feet with a large steam elevator for hoisting cars to the second floor is under construction and will be completed some time next month. One of the supervising engineers, H. M. Kelly, of San Francisco, has devised a slanting rail to be attached to pulleys at curves to prevent the cable slipping off and wearing itself out against the sides of the conduit.

Chas. K. Dickson, Secretary of the Northern Central

R. R. Co., has been made Superintendent of Construction of the Franklin avenue cable.

Work was begun on the Olive street cable August 19th. Some difficulty was experienced at first in getting workmen, but a heavy force was put on as soon as they could be obtained. The cars of the Olive street line were run over Twenty-third street to Market street, where they took the track of the Missouri Railway Co's other line, returning on Fifteenth street to Olive. This morning Olive street was abandoned to the workmen as far east as Eighth street. The cable conduit will be put in to Tenth street, and the street paved again before September 7th, the date when the Exposition opens. The Exposition building is on Fourteenth and Olive streets. When the Exposition opens, work will begin on the western end of the line and the eastern end will be left until the close of the Exposition, October 19th. The road is expected to be ready to operate November 1st. The main line will be extended from Grand avenue to Sarah street.

Late to-night the St. Louis Car Wheel Co's Shops, on the Missouri Pacific track, burned down, and with them the patterns for the cable yokes. O. W. Meysenburg & Co., the contractors, say that this will not interfere with their work at all.

It is reported that Chas. Green, President of the People's Railway Co., is endeavoring to sell his stock in the company, 2,200 shares.

In the fight over the franchise for a north and south road across the Tayon avenue bridge, between John Scullin and the Cable and Western road, neither obtained anything. The contest will be renewed in November.

The Cass avenue line will put in the cable next spring. The line runs from Broadway and Walnut street, on Walnut, Seventh street, Cass avenue, Glasgow avenue, St. Louis avenue, and Spring avenue, to the Fair Grounds, about three and a quarter miles.

G. G. B.

## American Cable Railway Construction.

BY AUGUSTINE W. WRIGHT.

PART I.—(Continued from page 161.)

Each pair of engines furnishes 400-horse power in ordinary working, and is capable of working up to 700-horse power. The pinion on the engine-shaft is 4 feet 1 inch in diameter and 20-inch face. It connects with a V-toothed gear 12 feet 6 inches in diameter, and 20-inch face, which in turn meshes with another gear of same size. Each gear shaft has two reels or drivers for the rope. The engines are set in pairs 19 feet apart. The diagram given shows the position of the engines with relation to the reels, guide-pulleys, and tension apparatus. The steam pipes for the engines were furnished by W. T. Garratt & Co., of this city. The exhaust pipes were made by H. W. Rice, manufacturer of portable engines and boilers, in this city, and a very satisfactory job he made of them.

The boilers in use are the first of the Babcock and Wilcox type ever put up on this coast. They came here all built and ready to put up, and are guaranteed to be of 250 horse power for each section, there being four sections. These boilers are very substantial looking structures. There is a Llewellyn water heater five feet in diameter and a fine pair of the Dow steam pumps, made in this city.

### THE DRIVING ARRANGEMENT.

The driving method is what is known as the American method of driving, and is about the same as that used on the "Gordon Plane" in Penn. Fig. 20\* shows the general arrangement. Two drivers, H, H, 12 feet in diameter, are placed in line. The rims are loose, and in between these rims are bolted blocks of wood two inches thick and set on end. Maple is used here, but beech is supposed to be better. The rope passes in from the street on a slight downward incline, just clearing the top of the forward driver and passing on to the top of the rear one (or that next the engine, K), it being set six inches higher than the other driver. It passes three-quarters of the way around,

\*See August GAZETTE, page 160.



and thence upward, diagonally forward, over the top of the forward one, then down and backward, just clearing the bottom of the rear one, to the tension sheave, M, on the tension carriage. There are only three-fourths of a turn on each of these drivers, or one turn and a half in all. Yet this drives 24,557 feet of rope with heavy loads. One would hardly suppose that mere friction of the rope would admit of this, but that it would slip. The tension apparatus is the secret of this result; without that it would be impossible. The automatic action of the weighted tension sheave, however, is such as to keep the rope closely jammed on the drivers, so that it is not easy for any slip to occur. The great advantage of this method is the small number of wraps on the drivers, as wraps on drivers form one of the principal sources of breakage and wear on cables. The improvements on the old English system (where numerous wraps are used) patented by S. B. Whiting in 1876-7, and used on the Brooklyn bridge, are unsatisfactory, for this reason: the friction wheel from which the power is derived, located in line between the shafts carrying the driving drums, relieves the bearings, but the old and principal fault of the wrapping of the rope still remains. As the part of the pulleys where the rope first comes on wears the most, the driver is not kept of uniform size. Therefore, the rope has to "overhaul" to compensate for difference in circumference between the sides of the driver where the rope comes and goes off. This overhauling throws excessive strain on the rope and soon breaks or tears it into pieces. By the system we have described as in use here this objection is overcome, the rope nowhere taking a complete turn of any driver. In the engraving F shows the Market Street cable; O O the Haight Street angle sheaves; P P the Market Street angle sheaves, and S S the cars on the tracks.

(To be continued.)

### On the Diamond.

The base ball fever appears to have struck the St. R. R. men of Cleveland.

The first attempt at base ball was with the Press club and the paper men made the Railway officials work as they had never worked before.

The R. R. team was composed as follows: Frank De H. Robison, J. Stanley, A. Honacker, C. Coleman, M. S. Robison, jr., E. Hewitt, A. Marshall, A. G. Hathaway and J. Honacker, while the Press club honors were held by nine scribes of the daily and local papers.

A special car on the Payne avenue line, of which Mr. Robison is president, took this would-be athletic collection to the ball park, several of whom returned four hours later in the ambulance.

The game started in favor of the Press club and for five innings it seemed as though they would completely eclipse the railroaders. The game then stood 15 to 9 against the railroaders, which looked very bad indeed, but in the sixth inning President Frank De H. Robison appeared at second base with a pair of large yellow drivers' gloves which some of the press men mistook for boxing gloves. It is needless to say that, from that on, the game went in favor of the R. R. men.

In the ninth, Stanley made a wonderful ballet catch on one foot, thereby retiring the side, giving the R. R. men four runs in excess of the Press club.

President Robison covered all the ground between first and third bases, coached all the men and occasionally proved the umpire a "boodler," at least so far as cigars were concerned.

The base running of Bell, Hathaway and Tello was very fine, while the coaching of Brunell in his "Father Hubbard" costume, has only been excelled by Latham of the Browns.

Supt. Robison in the latter part of the game managed to hit the grand stand in his praiseworthy endeavors to throw to first base.

The St. R. R. men in the grand stand were especially gracious to Alderman Athey who acted as umpire, and whose manly figure was much admired by the ladies. T.

(Continued in DIRECTORY SUPPLEMENT, p. 19.)

### The Woodward Storage Battery.

During the last week of August a public exhibition was given in Detroit of a storage battery, devised by Henry Woodward, of London, England. The battery consisted of twenty-four cells, each fourteen inches long by nine and a half wide and fifteen inches high. Each cell contained eight lead plates, and the solution was composed of minimum and diluted muriatic acid. The weight of each cell was eighty-five pounds. The patents in the United States covering this battery are owned by a Detroit syndicate, consisting of Robert McKinstry, C. H. Thompson, E. C. Brown, Geo. S. Terry, Charles A. Warren, J. M. Farland, Thos. Williamson, James Ronald, Frank B. Preston, Wm. Foxen, Frank B. Trout, E. M. Washburn and N. T. Thurber.

### Personals.

F. J. SPRAGUE, of the Sprague Electric Ry. and Motor Co., New York, is at Franconia Notch, N. H., convalescing.

DR. GEO. B. CALDWELL, pres. Citizens' Railway Co., Wheeling, W. Va., was in New York end of August, investigating electricity as a motive power. Subsequently he visited the Van Depoele electric railway system at Chicago.

GEN. A. K. STILES, of the Van Depoele Co., was registered at the Astor House, New York, the beginning of August.

H. A. EVERITT, sec. of the Ohio State Tramway Association, and also sec. of the East Cleveland R.R. Co., was in Chicago recently. He also went to Lima, O., to investigate the Van Depoele electric railway system in operation there.

A. J. SWEENEY, of Wheeling, W. Virginia, projector of the new electric railway there, has also been investigating the Van Depoele system, and recently visited Chicago.

HON. J. RUSSELL JONES, pres. Chicago West Division Ry. Co., is astonished at the wonderful abilities of newspaper men in getting information before the people concerned. He looks into the papers to see statements attributed to himself which he never uttered!

CHICAGO squirrel (up a tree)—"What do you want?" Mr. Yerkes—"I want more franchises." "Who are you?" "I'm one of the Philadelphia syndicate." "Don't shoot. I'll come down."—*Omaha World*.

WHILE Deacon Richardson, of Brooklyn, was in Liverpool recently, he received a telegram from London, "Meet me at the Langham Hotel. Lucy." The deacon had some difficulty in explaining this dispatch to his wife until he ascertained that it was Mr. Tracy who wanted to meet him, and not "Lucy." Mr. Tracy will sign his name more legibly hereafter.—*Chicago Evening Journal* (Aug. 22).

LAWSON N. FULLER.

At a recent informal meeting of New Yorkers, interested in street railways, Mr. Lawson N. Fuller was about to begin his oft-repeated discourse in favor of cable roads.

"One moment, Mr. Fuller," interrupted a representative of an underground railroad who had been in Europe for many years. "The last time I remember seeing you at a railroad affair was twenty-five years ago. You were delivering a lecture at that time on the subject of a railway in the upper Boulevard. While you were talking, I was compelled to leave in time to prepare for sailing."

"I hope my lecture did not drive you out of the country," said Mr. Fuller, laughing.

"Oh, no," was the reply, "but I did not hear the end of it until my return a few months ago, when I read it in one of the daily newspapers. I merely wanted to ask if this was the same lecture?"

And even Mr. Fuller laughed.

DEATH OF A. J. VANDERPOEL.

A famous lawyer, in street railway matters, has passed away. Aaron J. Vanderpoel, born in October, 1825, died suddenly in Paris, Aug. 22. He was a prominent member of the New York bar. He had been counsel for the Brooklyn bridge, the Western Union Telegraph company, and for various street railways. He helped to get the charter for the elevated roads.

## POINTERS.

## CALIFORNIA.

*La Presa.* The latest new town in Southern California is La Presa, up the Sweetwater River from National City, and a motor road is to be running to it by the first of November, and already a street railway is contemplated.

*Los Angeles.* A franchise has been granted J. H. Moon and his associates for an electric railway (storage battery) from Sante Fe depot to the western city limits.

A street railway franchise has also been granted to T. E. Rowan.

A serious accident happened on the Agricultural Park street car line, when the horses of a heavy timber wagon ran away, and the pole of the wagon went right through the street car, which was crowded (it being about six p. m.), and the passengers were knocked about right and left, but miraculously escaped death. Several were injured, but only two severely.

The Elysian Park Street Railway company has been incorporated. Capital stock, \$50,000; amount subscribed, \$14,000. Directors: J. S. Maltman, O. A. Ivers, W. S. Wills, Thomas Kelly, P. M. Scott, J. W. Scarborough and W. J. Marsh.

*Piedmont.* Experiments are being made at Piedmont with Casebolt's overhead grip cable car system. After it worked successfully the car and cable were photographed.

*San Diego.* The capital stock of the San Diego Street Car company has been increased from \$100,000 to \$250,000. This marks a new era in the street car lines here, and new cars and better facilities will be the result.

*San Francisco.* The people here are become so habituated to street car riding that the more accommodation they have the more is wanted. Considerable extensions have recently been made and much is now in progress—still the cry is for more. W. H. Martin, John Ballard, W. J. Adams, Thomas Magee and H. H. Lynch, representing the Powell Street Railroad company, have petitioned the Supervisors for permission to lay a double or single track, to extend from California street via Seventh avenue to the north end of Golden Gate Park west of the Bay District Racetrack, to run dummies to connect with the main line at Jackson street and Central avenue.

## COLORADO.

*Manitou.* A street railway is to be built here by Kansas City capitalists.

## CONNECTICUT.

*Ansonia.* The Derby Horse Railway Co. hope to have their road opened about November 1st. Its business will be freight principally.

*Birmingham.* The car-house and stables (80x50 ft.) of the Birmingham and Ansonia Horse RR. Co. are now completed—to the great comfort of the horses.

*Middletown.* The Middletown Horse RR. Co. still "think seriously of going into electricity."

## DAKOTA.

*Rapid City.* The Rapid City St. RR. Co. say they "will build over our city as fast as our condition will permit us to. We have a growing city."

## ILLINOIS.

*Aurora.* A certificate was filed with the Secretary of State, at Springfield, Aug. 24, to record the increase of capital stock of the Aurora City Railway company of Aurora to \$60,000.

*Chicago.* Rumors, gossips, reports continue to evolve in thick clouds from the sale of the Chicago West Division Railway, with its control over the Passenger Railway. The *Inter Ocean* has declared that the deal is all finished; and specials have been wired all over the country that Messrs. Elkins and Widener, of Philadelphia, representing the syndicate that owns valuable surface railways in New York, left Chicago for the East, Aug. 30, after having acquired a controlling interest in the West Division Street Railway company of this city. The newspaper statement nearest the truth, however, and which is in accord with the statement in the August GAZETTE (to the effect that the deal requires "perfecting"), is that in the *Chicago Tribune* of Aug. 30, saying: "The

West Division Railway deal is likely to go through any minute, and is likely to be delayed a fortnight," said a leading broker yesterday, "but it will certainly be a trade." Others were less sanguine as to the outcome of the negotiations, and a man who is well posted in regard to such matters expressed the opinion that the bidders could not get together enough money to bring the owners of the road to terms. Under ordinary circumstances the present stringent condition of the money market would be a serious obstacle to the consummation of so great a transaction, but the friends of the Philadelphia syndicate declare that that is the last thing to trouble them. Messrs. Widener and Elkins leave for Philadelphia to-day. It is stated that they have committed their interests to persons in this city who will carry the negotiations to a successful issue. Friends of the scheme say that a good deal of Chicago capital will be put into the purchase money along with the Philadelphia funds, and that there is more Chicago money in the North Side road than people generally suppose. One institution has \$500,000 invested there."

The La Salle Street Tunnel has been taken hold of by Mr. Yerkes, and the cable will soon be laid there.

*Hyde Park.* The cable extension of the Chicago City Ry. Co. down here will soon be in operation. The delay in finishing has been at the engine-house at Fifty-fifth street and Cottage Grove avenue and at the corner of Jefferson avenue and Fifty-fifth street, where the grip changes cables to make the turn around the "loop." Now, however, the delay is about over. The building for the engine-house is all finished except where the roof is left open to receive certain portions of machinery, and the boilers will be ready for use before the cable can be put in. A large force of men has been at work connecting the Fifty-fifth street track with the "loop," which passes South Park Depot on the Illinois Central. The stone foundations for the big wheels are laid, and everything is all but finished.

The consolidation of the Chicago & Calumet Terminal Railway company and the Hammond & Lake Michigan Railway company has caused some speculation in the lower end of Hyde Park as to what the new company (the Chicago & Calumet Terminal Railway company) proposes doing. It is understood the new organization will immediately set to work to build several miles of road throughout southern Hyde Park, touching South Chicago, Cummings, Hegewisch, Colehour, and Hammond. The officers of the new organization are the same as those of the former Chicago & Calumet Terminal Railroad, and the capital stock is now \$5,000,000.

*Lake View.* This new suburban city, on the north side of Chicago, recently passed an ordinance granting permission to construct and operate an experimental electric railway within its boundaries. Since then the mayor has vetoed the ordinance. But the prevailing opinion is that Mr. Yerkes will get there all the same. And we understand that if this experiment proves successful, electricity will be adopted on the West Side railways, when they come under Mr. Yerkes' control, instead of cable—newspaper assertions to the contrary notwithstanding.

## IOWA.

*Des Moines.* The Des Moines St. RR. Co. contemplate extensive improvements and additions.

## KANSAS.

*Abilene.* The Abilene Street Railway company (M. M. Shipe, president) would like to use dummies instead of horses, and wish us to refer to some one who would state cost of dummies, weight and power necessary to pull two cars up a grade of six feet to the hundred.

*Atchison.* The Atchison Street Railway company are putting down half a mile of new double track and one mile of single track, and contemplate further extensions.

*Fort Scott.* The Fort Scott Street Railroad company are making preparations for a very considerable extension of their line on the east side. They propose to build out Wall street to a point south of the foundry and machine shops, then north to a point near the shops. The road will run along the west side of Tallman's addition, and furnish facilities for everyone residing in that portion of the city.



*Horton.* A franchise has been granted to the Horton Street Railway company, who will begin the work of laying their line of road immediately. When one meditates upon the progress, Horton has made within the past year he is filled with amazement and wonder. A year ago the land upon which Horton, a town of 2,000 souls, is now located, was a vast field of waving grain.

*Hutchinson.* The Hutchinson Street Car company's new lines and extensions are being pushed as fast as a large force of workmen can do it. The Avenue A line is completed from Cleveland street to a point between Walnut and Main, and will be connected with the Main street line as soon as that portion of the old creek bed, which is being filled up by the city to widen the street, is filled up. The second track, on Main street has been completed, and cars are running regularly. On the Fourth avenue extension the street is down to grade, and the rails are being laid.

*Kingman.* The Kingman Street Railway company is now trying to make arrangements with C. D. Wright & Co. of the Kingman Electric Light Company, to have that company furnish the power to propel the street cars of the city by electric motors.

*Leavenworth.* The new dummy railway from Fort Leavenworth to the Soldiers' Home is to be completed and in operation by October 1st. The Memphis capitalists who are constructing it contemplate extensions so as to connect Leavenworth with Kansas City.

*Pratt.* The Pratt City Railway company has been incorporated; capital \$20,000. Directors: Geo. Kuhns, E. M. Kuhns, of Pratt; Geo. S. Chase, A. M. Chase and Jas. Gillett, of Topeka.

*Topeka.* Topeka now has ten miles of street railway running from Kansas avenue. "There will be cars and horses, even though there may not be enough people to ride," says our correspondent. Six of these lines run west from the avenue.

The City Railway company show that they are endeavoring with all reasonable haste to get their lines in good running order. The unavoidable delay of their material has greatly retarded the work. It is daily remarked on the streets that this company ought to get motors for their lines, either electric or steam, and be able to compete with the facility in motion of the Rapid Transit. "The City railway is a popular institution and these modern improvements are all it lacks in the estimation of the citizens."

This seems in a fair way of being accomplished. For as soon as General Manager Dean will return from Boston, a location is to be applied for and extension west of the city to be operated by steam motors. We are informed this company contemplate introducing electric motors also.

The Rapid Transit cars are now running on schedule time. A good business is being done, and the passengers are delighted. Four new closed coaches are on the way to Topeka and will be put on the track at once upon their arrival. It is said that the word "daisies" can give no idea of their beautiful design and elegant finish.

**A STREET RAILWAY WAR!** Since the above pleasing account was written and set up in type, we have received a copy of the Topeka *Capital*, dated Sept. 4, which contains over a newspaper column of report describing a "row" between the Topeka City Ry. Co. and the Rapid Transit street Ry. Co. The tracks of the Rapid Transit street railway company at the intersection of Tenth avenue and Jackson street had been laid under that of the City railway company, the excavation being about sixteen inches, owing to the difference in grades of the two thoroughfares. A proper crossing had not been put in, owing to the fact that the City railway company had neglected to lower their track to the grade of the Rapid Transit as ordered by the city council. The Rapid Transit company sent a force of nine men to lower the track of the City Railway company and complete the crossing. They commenced removing some ties which had been placed under the company's tracks for support, but were soon interfered with by a larger force from the City Railway company's barn, and for over an hour the contending forces were engaged in pulling out and putting back ties. Two cars were

run down by the City railway force and fastened at the crossing with chains and locks. Ultimately Mayor Metsker appeared on the scene. A wagon load of police arrived when all was over. A special meeting of the city council was hurriedly called, and finally everything was settled satisfactorily. "All's well that ends well."

*Winfield.* The Union Street Railway company contemplate a further extension of a couple of miles. The line is being extended through Riverside park across the river to North Winfield and also on Ninth avenue, and when completed will aggregate several miles in length. A new car was recently placed on the road. It is somewhat smaller than the old ones, but is very convenient, and "a beauty in appearance." It is No. 4 and is marked "the college, depots and hotels." The Laclade car works of St. Louis built it, and "it is a credit to that company and also to the Union Street Railway company."

#### LOUISIANA.

*New Orleans.* Acting Controller Newman advertised for bids for the Canal and Claiborne St. RR. franchises, and proposals were to be opened Aug. 26th. We understand, however, that the franchise is still in the market.

#### MASSACHUSETTS.

*Boston.* The Metropolitan Railroad company has been granted permission to lay double tracks and make connections for 1,000 feet on Lexington street, East Boston. Also to lay a single track on Hudson street, Dorchester, and on Hanover street between Commercial street and Chelsea ferry. The same company will probably lay double tracks on Charles street and Leverett street.

#### MISSOURI.

*Independence.* The work on the Kansas City, Independence & Park railway continues interrupted. The news that the road had been sold to the Grand Avenue Cable company, of Kansas City, was received with much pleasure, as connection with some city road was necessary to get into the heart of Kansas City. The people of Independence, having a very high regard for Mr. Winner, rejoice that there has been such a rich harvest to him financially in the building of the road and developing land in the city and south and west. It originated the boom in real estate and has been no mean factor in sustaining it.

*Kansas City.* An ordinance has been presented to the city council for granting to the Indiana Avenue Motor company the right to construct and operate a single track street railway on Indiana and Springfield avenues. The road will begin on the former avenue at Twelfth or Fifteenth streets and extend south to Springfield avenue, and thence east to Cleveland avenue. The new corporation has a capital stock of \$50,000, and the incorporators are William H. Jones, Warren B. Sexton, and Edward C. Parker. It is expected to have the road completed within a year and a half from the approval of the ordinance.

*St. Joseph.* Mr. Hobson intends to have the Miller system for the Wyatt Park Cable railway, the same as used on a New York line. "Although it costs much more," says Mr. Hobson, "in my estimation it is far preferable to any other. It has a complete double set of machinery with a double cable and there is no such thing as being delayed by broken cables. If one cable snaps all you have to do is to hook on to the other one and you can go right ahead until it is replaced."

*St. Louis.* The St. Louis Cable and Western R.R. Co. put in a new drum at their power house during the last week in August, measuring twelve feet in diameter and having ten grooves. It is about one-third larger than the old drum, which has given much trouble in the past. Three new Pullman coaches and nine Coney Island summer cars are being placed on the steam division of the road, and the new cable is expected to be ready for delivery by the middle of this month (September).

*Wyandotte.* About 150 men who have been employed in the work of constructing the River View cable line, gathered at the River View end of the line the afternoon of Aug. 16th, and clamored for their pay. They claim they have received no money in two weeks. The contractor, McDonald, had not been seen in Wyandotte in several days

previously, and it is said that he is at Sweet Springs. At last accounts the demands of the men had not been satisfied.

#### NEBRASKA.

*Omaha.* Dr. Mercer has ordered ten Pullman cars for the electric railway (Van Depoele system) now being constructed here.

#### NEW JERSEY.

*Asbury Park.* The Sea Shore Electric Railway Co. (Daf system) are crowded with passengers, and more cars are urgently required.

#### NEW YORK.

*Auburn.* The Auburn City Ry. Co. are constructing a mile and a half of street railway; also two and a half miles of steam railway from the city to Owasco Lake (summer resort). The new street line is to be laid with 45 lb. steel rails.

*Brooklyn.*—The electric railway (Van Depoele system) is progressing rapidly. The track is being relaid with new rails, and new cars are ordered from Pullman. It will be completed and in operation by about the middle of October.

A suicide occurred here August 29th. A man, apparently forty-five years of age, threw himself from the platform of the Elevated Road at the Lexington and Summer avenue station, falling in front of a train. He was torn to pieces by the locomotive, and portions of his body fell to the street below. In the man's pocket was a card bearing the words, "My address, A. Gally, 315 Broadway, New York City." There was also \$1 in money and some circulars of eating-houses.

Work is now advancing rapidly on four elevated railroad systems in Brooklyn, and if the promises of the projectors of these roads are fulfilled, the first of January, 1888, will see trains running on all the new routes. Elevated railroad projects have had many difficulties to contend with in Brooklyn, and even now work on some parts of one of these roads is interrupted because of injunctions obtained by abutting property owners. The only elevated railroad in operation in this city is the Brooklyn Elevated Railroad, which, by a roundabout route, brings passengers from East New York to the East River Bridge and Fulton Ferry, traversing a sparsely built-up district of the city, except when it traverses the Seventh, Twenty-third and Twenty-fifth Wards. The most important of the new roads now building is that of the Kings County Elevated Ry. Co., which is to run through Fulton street from Fulton Ferry to the city line, a distance of about five and a half miles. Work was begun on this road a year or two ago, and two spans of the structure were erected in the neighborhood of the City Hall. Last summer work was begun again, and, despite many difficulties, it has been pushed forward rapidly. Now all the foundations for the superstructure are completed, except in the two or three blocks between the ferry and the entrance to the bridge on Sands street. These foundations are laid on the curb line, and there are no obstructions in the roadway, except when other streets intersect the line of Fulton street at acute angles. The work of erecting the superstructure was begun at Grand avenue. The iron spans crossing the street, and the longitudinal girders on which the tracks of the road will be laid, are hoisted and placed in position by means of steam derricks built on heavy wooden carriers. The superstructure is now in position as far down town as South Portland avenue, covering a distance of about three-quarters of a mile, and advancing at the rate of about 150 feet per day; and it is expected that the road will be in running order from the Ferry to Franklin avenue, a distance of about three miles, by the first of January next. The contract for the locomotives and cars has been given out, and a full equipment will be in readiness for use as soon as the rails are laid.

The other railroad enterprises now in progress are under the direction of the Union Elevated Railroad company, which has been consolidated with the Brooklyn Elevated Railroad company, and these roads will, when completed, be run in connection with the system now operated by that corporation. Through Hudson street all of the foundations are laid, and where this street crosses Fulton the company

has erected a span of its structure. This was done to block the way of the Kings County company, but the difficulties between the two companies have, it is claimed, been adjusted, and the structure of the Kings County company will pass over that of the Union company at this point at a height above the street surface of about thirty feet. The latter company is to lower the structure it has in position at the contested crossing. The foundations are in place along Flatbush avenue, and the work is being pushed forward rapidly in Fifth avenue, except where restrained by injunctions.

The other branch road now building is on Broadway, from the ferry at the foot of that thoroughfare to Lexington avenue, where it connects with the Brooklyn Elevated Road, extending to East New York. The structure here spans the street, and work is going on very satisfactorily. The foundations are completed about one-third of the distance and the columns and superstructure are in position for about three blocks. This route will be a favorite one for the German citizens of Brooklyn to reach the cemeteries contiguous to East New York, and will also be the most direct route for people living on the east side of New York city to reach that point, where connection can be made with Long Island Railroad, the Manhattan Beach Railroad, and the railroad to Canarsie.

Elevated railroads are projected in Atlantic avenue throughout its entire length, Boreum place, and Kent avenue, but up to the present time nothing has been done on any of them except in Atlantic avenue near the ferry where a few excavations were made and foundations laid.

A new phase has been put upon the efforts to rid Thirty-sixth street, Brooklyn, of the railroad tracks placed there by the Brooklyn, Bath and West End Railroad company. Judge Cullen recently refused an injunction to prevent the city from interfering with the tracks, and City Works Commissioner Conner gave the company ten days in which to remove the tracks. But instead of taking up the rails the company sought by every means to get the consent of the property-owners, who were seeking to get rid of the road, to permit the tracks to remain, and meantime applied to Judge Barnard, in Poughkeepsie, for an injunction. Deputy City Works Commissioner Murtha and a force of men went to the street on the morning of Aug. 17 to take up the tracks as the ten days' limit had expired. But before any work was done they were served with injunction papers, which were based upon a representation that the consent of a majority of the property owners had been secured when Judge Cullen denied an injunction.

*New York.* Wall street was greatly exercised the last days of August over the decline in Manhattan Railway stock, and everybody endeavored to explain a reason therefor. "The street" argued that, if Mr. Jay Gould paid 120 for fifty thousand shares of Cyrus W. Field's Manhattan stock, and a syndicate paid the same price for twenty-eight thousand shares more, there must be some remarkable reason for the decline of 25 per cent. below the figures paid. Probably the best reason for the decline is that the people whom Wall street expects, or has expected to support the stock got about all they wanted at 120, and could not afford to average very extensively above 100.

The returns of the Street-Railway companies show that the earnings of the Third Avenue Co. have increased 40 per cent. as compared with the same time last year, and that this company is now paying a dividend of 3 per cent.

The directors of the Broadway & Seventh Ave. RR. Co. contemplate a change in their transfer system which was introduced in January. Passengers having paid a fare on a Broadway car have, upon request, been handed a transfer ticket which is good for a ride on the cross-town cars on Houston, Grand, Prince and Chambers streets, and persons paying a fare on any of these cross-town cars have been transferred at Broadway with a slip good for either a downtown or an uptown ride on Broadway. Many passengers have been in the habit of putting the transfer slip in their pockets and using it later in the day, instead of making immediate use of it on a continuous journey. The company has thus lost many fares, and it is probable that a new trans-



fer slip will be put in service good only within the hour punched out by the conductor at the time he hands it to the passenger.

A regular meeting of the Rapid Transit commission was held at the Equitable Building, August 15. Louis Fitzgerald presided. The other commissioners present were James B. Smith, Stevenson Towle and Thomas C. Clark. C. E. Morse presented a plan of rapid transit for a steam elevated railroad from the Battery to Harlem River, express trains to be run in thirty minutes. According to the model presented, this structure is to be built of dense cast tubular steel. A shield to prevent water, oil or anything from dropping on the streets is provided; also a conduit to carry down to the streets whatever may accumulate under the tracks. All the ferries above City Hall are to be connected with the main line.

On the part of the Broadway Transit company, for an elevated steam railway from the Battery to Forty-second street, J. M. Hannah presented a supplemental paper setting forth that the double track would occupy thirteen and a half feet only. At the narrowest point in Nassau street, which is thirty-two feet in width, a space of nine and a half feet on each side would be left clear. By the use of small steel ties, three feet apart, but slight obstruction to the light of the street would be caused. As it was to be a cable road, there would be no noise, ashes or gas. There would be four car wheels only, and these incased in wood would be rendered noiseless. The cars would be no wider than the ordinary horse cars, seating fifteen persons on each side. Cars, single or in trains, as required, would start every half minute. At the terminus the cars would come around on a circle, obviating the necessity for switching, and no unused cars would stand in the street.

Henry D. Sedgwick, representing the New York Underground Railway, filed a brief, proposing a new and additional route, south of Lafayette place, to the City Hall, under Elm street, this street to be extended and widened so that four tracks could be laid from Bleeker street north to Forty-second street, but there would be only two tracks south of Bleeker under Mulberry street. This would assure the double advantage of four tracks from City Hall to Forty-second street, and at the same time bring the line south of Lafayette place nearer to Broadway.

Lawson N. Fuller, on behalf of the property-holders west at Central Park and at Kingsbridge, took the ground that the rapid transit schemes proposed up to date did not meet the needs of the people. He was of the opinion that a road should run through Tenth avenue to the end of the island. Mr. Fuller urged the board to locate the road through the boulevard, and said that the Legislature could then be petitioned to repeal the act excluding the boulevard.

*Rochester.* Since our last issue the directors of the three companies who contended for disputed rights on the Boulevard have held a conference, when each presented a proposition for the acceptance of the others, and the prospect at present is for a union company. The electric motor will be used for power. This all the companies have agreed upon.

#### OHIO.

*Cincinnati.* The North Cincinnati Cable railway is nearly ready for operations, and the opening day is to be celebrated in style becoming the dignity of the Queen City. The work has been proceeded with night and day; and a "committee on arrangements" have appointed sub-committees to carry out a "big celebration." This is expected to occur in the last week of September.

*Cleveland.* Articles of incorporation have been filed with the secretary of state by the Garden Street Railway company, of Cleveland, capital stock \$250,000, the incorporators being Thomas B. McKearney, H. L. Vail, P. I. Spenser, A. H. Stöhlmann, Daniel Marshall and Charles Body. The shareholders say: "We, the undersigned, do hereby severally subscribe for the number of shares of the capital stock of the Garden Street Railway company set opposite our respective names, and do agree to pay therefor the sum of \$100 per share upon the following conditions, however which are and shall be binding, as part of this contract of

subscription, between each of us respectively, jointly, and severally with each other and with said corporation.

"Said corporation within thirty days after 50 per cent. of its capital stock is subscribed, shall apply to the common council for a grant of permission to construct and operate said railroad on Garden street, from Willson avenue to Brownell street, and from the easterly and westerly terminus by such other routes, westerly to and on Superior street, easterly upon such ways, streets, etc., as may be deemed advisable; and as a part of said application it shall agree with said city of Cleveland that it will pave said street from Brownell to Willson with Medina block stone at its own cost, and will during the period for which said grant is given keep and maintain said pavement in good repair, to such width as shall be decided upon by said city, except such breaks therein as are made by reason of sewer, water or gas connections."

The following agreement is to back the Garden Street company's petition for a franchise: "We, the undersigned, owners of real property fronting on Garden street, in the city of Cleveland, hereby consent that the Garden Street Railway company may and we hereby request our common council to grant permission to it to construct, operate, and maintain a double track street railway on said Garden street between Willson avenue and Brownell street; and we hereby give and consent respectively for and on behalf of every foot fronting on said Garden street, as set opposite our names, and we hereby waive all claims to damages by reason of the construction and operation of said railway on said street."

"Still a muddle," "verbal fireworks," and "on the war-path" are some of the attractive captions over columns of newspaper reports of the Franklin avenue fight. The bone of contention and personnel were stated in the August GAZETTE. There was "a sharp discussion" before the Board of Improvements, Aug. 22; and on Aug. 30 Judge Noble issued a temporary injunction in response to the application of several property owners, restraining the Woodland & West Side Railway company from occupying Franklin avenue.

On the same day the city council received a petition from the Woodland Avenue & West Side Street Railway company, asking for permission to extend their double track across the Abbey street branch of the Central Viaduct and through Jennings avenue, Willey street and Scranton avenue. The last clause in the petition is as follows: "The design of the extension is to immediately construct across the Central Viaduct to Jennings avenue, from the corner of Pearl and Lorain streets, an extension of the double track road of the Woodland Avenue & West Side railroad; thence along Jennings avenue to Willey street, thence out Willey street to Scranton avenue and along Scranton avenue as far as the city limits, intending to extend the same beyond the city limits to Riverside cemetery, and to operate said extension by cars running each way through Abbey street until the Central Viaduct across to Ohio street is completed, then to operate a line of cars across said Central Viaduct and provide for transfers upon any branches of the Woodland Avenue & West Side Street Railroad company."

#### PENNSYLVANIA.

*Eaton.* The contract has been let for the construction of an electric railway up College Hill at Eaton, Pa. The road will be about a mile long, and will ascend a hill which has an 8½ feet grade for over 1,000 feet. The Daft system is to be used, and the road fully equipped will cost \$18,000.

#### RHODE ISLAND.

*Woonsocket.* The new street railway here is about to substitute electricity for horse power. "The overhead system has been adopted," says our correspondent, "and wires connecting with dynamos are extended 18 feet above ground, and joined to the cars by wires which slide on the upper wires by means of rolling trolleys. The electric motors are placed under the floors of the cars, and they will be lighted by four incandescent lights of twenty-candle power each."

## WISCONSIN.

*Milwaukee.* The Milwaukee Electric Railway Company has applied for a franchise to construct and operate an electric railway through several streets of the city. The Van Depoele system is contemplated. And it is to be "a popular people's line," with reduced fare, etc.

## CANADA.

## ONTARIO.

*St. Catharines.* The Van Depoele Electric Manufacturing Co. hope to have their apparatus in operation on the St. Catharines, Merrilton & Thorold St. Ry. (which connects the three towns, and is 6 or 7 miles long) by the end of the present month (September.)

## SIAM.

*Bangkok.* His Majesty, King Chulalongkorn, has granted Captains A. J. Loftus and A. Richelieu, two Europeans who stand high in the king's favor, the sole right for fifty years to lay and operate a tramway in the city of Bangkok, which will necessitate the laying of at least twenty miles of rail.

## Books, Periodicals, Pamphlets, Etc.

*Report* of the fourth annual meeting of the Street Railway Association of the State of New York has just been issued, giving full text of papers read and discussions thereon, together with list of officers, committees, etc.

*National Car Builder Supplement* (July, 1887) contains a list of street railways in the United States and Canada, etc., giving their gauge, weight and style of rail, mileage, number of cars and horses, etc., with officers' names and addresses. This is issued by Mr. John N. Reynolds (140 Nassau street, New York) semi-annually. And it was in the *Car Builder "Supplement"* that the first directory of street railways ever appeared. The companies are arranged alphabetically in cities and towns, the State being specified after each; and there is none to compare with it under that arrangement. On the whole the Reynolds' (or Car Builder's) Street Railway Directory is well got up—is very creditable and useful for reference, especially when one may not remember in what State a city he may want to refer to is situated. We know of but few street railways (in America) that are not included in this list; but there are some (in full operation too) which have escaped notice; such, for instance, as the Santa Ana, Orange & Tustin St. RR. Co., in California. On the other hand, there are companies in this directory which have been *non est* (by consolidation or otherwise) for some time: the Birmingham & Pratts Mines St. Ry. Co., Birmingham, Ala., is a case in point; and, by the bye, the "printer's devil" (probably) has transposed this from its legitimate place (Birmingham, Ala.)—if it had a right to be inserted at all—and put it under Binghamton, New York. The few errors that we have been able to discover, however, are but "mere flea-bites," and taking it for all in all (as the poet would say) there is nothing like it, and it deserves a place in every street railway office, and especially in the offices of manufacturers and supply men, side by side with our own OFFICIAL DIRECTORY OF THE STREET RAILWAYS OF THE WORLD.

*Poor's Directory of Railway Officials* (1887). This and POOR'S MANUAL are great books—the leading books of reference in railway circles. This is the second (annual) issue of the Officials Directory, which contains (in addition to the steam railroads throughout the country) a list of all the street railways of America, with their officers, mileage, gauge, weight and style of rail, number of cars and horses, etc. The special advantage of Poor's list of street railways is that the companies are classified alphabetically in States. It only comes once a year, however; and although it is useful and reliable as far it goes, Poor's Directory soon becomes old. The present issue is only just out, and yet many changes have taken place, not recorded therein. For instance, the body of the directory contains information about the street car lines at Auburn, New York, as they were operated last year; and the *latest* information, at the end of the book, is now

obsolete, although it gives the appointment of Mr. J. L. Windsor as superintendent, which took place last May.

*Cable or Rope Traction*, as applied to the working of street and other railways, is the subject of a treatise by J. Bucknall Smith, C. E., being a reproduction in book form of a series of articles thereon in *Engineering* (London), revised and enlarged. The book is elegantly got up, being printed in London, on very fine paper, and contains 195 pages, crown quarto. There are 37 first-class illustrations. "The chief object of this volume is to describe the application and development of a comparatively novel system of mechanical traction for street and other railways, known as the *Endless Cable Haulage System*." The Kasmussen and other cable railway systems are not noticed. But the book treats fully of the system of cable railway, which originated in San Francisco, Cal., in 1873, and it contains such valuable information (adequately indexed) that no street railway company, nor any one interested at all in cable railways, should be without it. "This work is dedicated, by the author, to William Munton Bullivant, Esq., as a tribute of respect and recognition of his ability and enterprise shown in connection with the introduction and establishment of cable traction for tramway working in Great Britain." The book is published in London, at the offices of "Engineering," 35 and 36 Bedford st., Strand, W. C., and in New York, by the well-known firm of John Wiley & Sons, 15 Astor Place. Price, \$2.50.

## EUROPEAN TRAMWAYS.

*Union Internationale Permanente de Tramways, Réponses au Questionnaire soumis à la discussion de l'Assemblée Générale réunie à Vienne les 1er, 2 et 3 Septembre, 1887.* We have to acknowledge, with thanks, a pamphlet bearing the above title, together with a circular containing the programme of the reunion and the order of the day for the general assembly of the International Tramways union at Vienna, held on the 1st, 2nd and 3rd instant. The pamphlet containing the answers to the questions submitted to the various members of the union, comprises fifty folio pages, and the responses are valuable in their completeness. The subjects under consideration include division of cars into classes; system of charges; style and cost of uniforming employees; cost of renewal of animals; cost of renewal and duration of rolling stock, and systems of pensions, insurance and assistance to employees. The last named subject is of special interest to American street railway companies, and the responses are very suggestive.

The question submitted is as follows: What are the plans of the institutions of annuities (or pensions), of insurance, and of aid in case of sickness, by which your employees are affiliated with the members of the association?

Responses are given from eighteen companies, including the Compagnie Générale des Omnibus, of Paris, the Deutsche Local und Strassenbahn Gesellschaft, of Berlin, and the Wiener Tramways-Gesellschaft, of Vienna. The response on behalf of the first named company is given by M. Delnochat, engineer. Briefly stated, the insurance system is regulated as follows: The fund is supplied by certain sums retained from the wages of the employees, depending upon the pay received by them; by fines imposed for infraction of rules; and by provisory subventions authorized by the directors.

(1) Employees at fixed salaries, as conductors, drivers, etc., pay into the fund, 1 franc a month; (2) grooms, relay-men, etc., 75 centimes; (3) night watchmen, etc., when old employees retired by the company, 50 centimes; (4) women employed at exchange stations, 75 centimes; (5) cleaners 50 centimes.

In case of suspension from service on account of verified sickness, under conditions reserved in the rules, employees receive from the fund daily indemnities as follows: Those of the first class, 2 francs; second class, 1½ francs; third class, 50 centimes; fourth class, 1 franc; fifth class, 50 centimes. The right to the stipulated indemnity begins only with the verification of the sickness by the company's physician; if the sickness lasts longer than twenty days the first three days are not counted. The indemnity is paid



only during two months, the resources of the fund not admitting a longer care of the incapacitated.

The retention of the monthly tax is voluntary on the part of the employees, and the expense of the physician is borne by the company.

The German company of local railways has in one of its branches a fund for giving aid in case of special sickness, to which each new employe must subscribe. If he has not, in the thirteen weeks preceding his connection with the company, been affiliated with any other aid society, or if he has not contributed to the Communal Aid Fund, he must pay an entrance fee equal to six weeks' dues, *i.e.*, 50 pfennig. Dues are fixed at 1½ per cent. of the salaries; the company paying into the fund an equal sum; and collections from fines and penalties are also added thereto.

From the fund, aid is given as follows :

(1) Medical attendance from beginning to end of the sickness. (2) In case of incapacity for work, beginning with the third day of sickness, an indemnity equivalent to half the actual salary of the insured person; this indemnity being paid during thirteen weeks at the longest. (3) In case of death the fund pays a sum equal to twenty times the ordinary wages of a day laborer in that place.

The plan has given excellent results, and the balances carried over at the end of each year have steadily increased. This good result is partly due to the mutual assistance given by the employees to one another, in giving their own services during a certain number of days, to supply the places of disabled fellows, so that the latter may receive their regular salaries, without drawing upon the insurance fund.

In the other branches of this company the plans for aid in case of sickness comprise the following provisions: Employees are obliged to join the aid funds of the locality; the management pays into these funds the weekly dues of employees, retaining from their salaries a portion of the total amount, in such proportion that the company itself contributes an amount equal to 50% of the sums paid by its employees.

In case of sickness, indemnity and medical attendance are accorded from the first day of incapacity for work, if the incapacity endures eight days or less. Indemnities are paid during six months at the longest. In case of death the fund pays, in general, 30 marks.

The Vienna Tramway company has established a pension fund for employees and a fund for insurance and aid in case of sickness of workmen. The company pays, according to law, into these funds ½% of its gross receipts from the transportation of passengers. This amount is divided as follows: The pension fund receives a sum equal to the sum total of payments by employees, and the aid fund receives the balance. Employees pay into the fund 5% of their annual salaries, besides a fixed amount which they give each time they receive an increase of salary. After ten years of service they are entitled to pensions in their old age; and their widows draw pensions for themselves and for their children, under 18 years of age. The workmen pay into the aid fund 3% of their daily wages. In case of sickness they receive during twenty weeks, besides medical attendance and the necessary medicines, an indemnity equal to half their wages. This indemnity is increased to two-thirds the salary when the workman has been injured in the service.

If a workman, after ten years' service, becomes an invalid, or if he is permanently disabled by an accident received in the service, he receives an annual pension equal to one-third of his wages. In case of sickness the families of workmen receive medical attendance at a reduced price.

The widow of a workman that would have been entitled to a pension, receives a pension equal to one-sixth of the wages earned in his last situation by her husband, besides an equal sum for each of her children under 14 years. In case of death the parents of the deceased receive 30 florins for funeral expenses, and in specially worthy cases, the managers of the fund may accord special additional assistance to the survivors.

ADOLPH TOELLNER, chief promoter of the new electric railway in Milwaukee, was recently in Chicago.

## Business Notes.

Pizzotti & Bellone, of Via Principe Tommaso 30, Turin, Italy, are negotiating with the Van Depoele Electric Mfg. Co., Chicago, for apparatus and equipment for an electric railway, at Turin, 11802.20 kilometers long.

The Roebling Co., of Trenton, N. J. have lately purchased the Seal patent for making cable road wire ropes. They claim that cables made under this patent during the past two years, have given far better results than the old style cables. During the past few weeks cables for the following cable roads have been shipped from Trenton: The Chicago City Railway Co., Chicago; Metropolitan Cable Railway Co., Kansas City; Grand Avenue Cable Railway Co., Kansas City; Kansas City Cable Railway Co., Kansas City; Tenth Avenue Cable Railway Co., New York. Also Philadelphia Traction Co., Philadelphia, and several to San Francisco, Cal.

THE consolidated elevated railroad companies of Brooklyn have contracted with the Rhode Island Locomotive Works for 45 new engines, and with the Gilbert Car Manufacturing Co. for 150 cars.

THE Sprague Electric-Railway and Motor Co.'s newly opened branch office, at 700 Kansas av., Topeka, Kansas, is considered by the business community there as an important addition to Topeka's means of prosperity, inasmuch as all the business of the Sprague people in Kansas is to pass through that office. Mr. W. S. Elliot is manager, and is assisted by a full staff of clerks and agents.

JOHN STEPHENSON COMPANY, limited, New York, recently fitted out the Mt. Adams and Eden Park Inclined railway, of Cincinnati, with sixteen new open cable cars, and they are about to make shipment of others, both close and open, to the new Vine Street Cable railway, of the Queen City. The Stephenson company also sent out, August 18th, the first installment of new cars for the Belt line (Central Park, N. & E. River R.R. Co.), New York, all of whose cars were burnt recently. This original street car building establishment is now employing a larger number of hands than ever, and is pressed to its utmost capacity. Orders on their books cover eighteen states of the union, and all points of the compass—for instance, in Massachusetts, new Stephenson cars are to be shipped to Boston, Lowell, Taunton, Stoneham—Connecticut: Meriden.—New York: New York city, Brooklyn, Newburg, Rome, Utica, Elmira, Binghamton.—New Jersey: Elizabeth, Orange, Keyport.—Pennsylvania: McKeesport.—Georgia: Atlanta.—Florida: Jacksonville, Pensacola.—Tennessee: Nashville, Knoxville, Columbia.—Maryland: Baltimore.—Dist. Columbia: Washington.—Missouri: St. Louis, Kansas City.—Kansas: Arkansas City, Topeka.—Arkansas: Pine Bluff.—Nebraska: Omaha, Lincoln.—California: Oakland, San Bernardino.—Kentucky: Covington, Owensboro, Paducah.—Ohio: Cincinnati.—Vermont: Burlington. Also to Ottawa, Ont.; Mexico and New Zealand. The John Stephenson Company are also adapting cars to cable and electric motors.

## Patents.

The following list of recent Patents relating to Inter-mural traffic is specially reported for THE STREET RAILWAY GAZETTE by Wm. H. Henderson, Solicitor of American and Foreign Patents, 925 F Street, Washington, D. C. A copy of any of the following will be furnished by him for 25 cents.

*Issues of August 2d, 9th, 16th and 23d, 1887.*

- 367,699. Street car brake—C. H. B. Burris, St. Louis.
- 367,541. Car starter—J. M. Linscott, Worcester, Mass.
- 367,467. Cable railway grip—W. J. Thomas, San Francisco.
- 367,765. Railway switch—J. W. Roberson, Red River Station, Tex.
- 367,609. Foot guard for railway switches, etc.—E. P. Edwards, Webster City, Iowa.
- 367,607. Railway track and rail—J. Fitzgerald, Girardville, Pa.
- 367,655. Combination crossing and switch for railway tracks—A. J. Moxham, Johnstown, Pa.

- 367,887. Elevated railway—R. M. Beatty, Hackensack, N. J.  
 368,291. Cable tramway—J. S. Lake, Pleasantville, N. J.  
 368,838. Car brake—J. C. Larkin, Lancaster, N. H.  
 368,581. Car brake and starter—D. Goff, Millville, N. J.  
 368,625. Street car motor—A. W. Getchell, Cleveland.  
 368,695. Car starter—J. R. Tracy, Toledo, Ohio.  
 368,812. Sand box for street cars—C. Clark, Brooklyn.  
 368,668. Cable railway—J. B. Heverling, St. Louis, Mo.  
 368,783. Elevated railway gate—R. Rinaldi, New York.  
 368,638. Railway rail—H. T. Wilson, Hendersonville, Tenn.  
 368,714. Securing railway rails to metal sleepers—L. P. Goffin and E. Vanriet, Brussels, Belgium.  
 368,576. Conduit for electric railways—F. Euphrat, Boston.

### New Mode of Warming Street Cars.

We call attention to the new mode of warming street cars with the Cline Patent Heater and Aromatic Carbonic Composition Fuel, the same being adopted by several companies whose testimonials appear on page 8 of our Directory Supplement. The great advantage of this invention over all other modes of heating is that it takes up no seating capacity, as it occupies but a small space and is placed under the seat. It is an ornament as well as heater, and can be made to fit any car. No cutting of car is required to put in the heater, and it will not destroy the paint. Should a break-down occur, the heater can be removed in a moment and placed in another car without any fear or danger.

The fuel which is used in the heaters differs largely from all others, viz.: that it burns downward and heats upward. The cost of fuel is cheaper than any other mode of heating.

The fuel is a black composition, perfectly harmless, and will not injure the finest fabric—is free from all smoke and entirely safe in handling. It is guaranteed healthy, and can be lighted by a child. Two quarts of Cline's fuel placed in one of the pans, will burn about fifteen hours, and needs no further attention when once started in the morning.

### The Coming Electro-Locomotive.

Another field, and one in which the electro-locomotive of the future may be expected to achieve its greatest triumphs, is that of rapid passenger traffic between our chief commercial centres. Steam locomotion, so far as speed is concerned, has practically reached its limit. The unavoidable restrictions of bulk and weight forbid any material increase in the power of the express locomotive of to-day. No such restrictions apply to the electric engine. The amount of power which by this means it is possible to apply to the axles of an ordinary train without materially increasing its weight, may, without exaggeration, be said to be almost limitless. We believe that the rapid transit railroad of the future will have its trains propelled by electricity; it will be straight, as the crow flies; it will follow the topographical undulations of the country almost regardless of grades, and its trains will attain a speed of more than 100 miles per hour with safety. Without doubt, this may be looked forward to as the next great step in the progressive improvement of the art of transportation.

It remains to speak of another development of electric transport, which for some occult reason has failed, at least in this country, to attract the attention that its importance deserves—the telpher system.

This ingenious invention, although apparently perfectly successful at Glynde, England, where it has been for quite a long time in practical operation, can be expected to have but a limited field of usefulness in the land of its nativity, compared with that which awaits it in the rugged and mountainous regions of our western mining states, to say nothing of the vast undeveloped territories of Mexico and Central and South America.

We have thus briefly indicated some of the probable future lines of development of electric transportation. Doubtless many others will discover themselves from time to time, as the ceaseless march of improvement goes on.—*Electrician and Electrical Engineer.*

## TYPE-WRITERS

"Remington Standard."

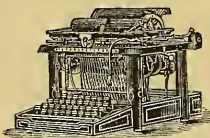

Full Line of  
Supplies  
and  
FINEST

Linen  
Paper.

Send for price list. The Standard is  
Superior in Mechanism, Ease of Operation,  
Speed, Durability and Principle  
of Construction.

Over 30,000 in Use. Fully Warranted.

WYCKOFF, SEAMANS & BENEDICT,  
196 La Salle Street, Chicago.

PRICE LIST on APPLICATION.

CHAS. H. MITCHELL,

Attorney and Counsellor at Law.

Practice in all the Courts. Railway Litigation a Specialty. Special attention to Patent Cases and Collections. Prompt attention to Correspondence outside the city. Refers by permission to THE ENGINEERS' CO., THE WRIGHT-MONROE CO., and others.

161 La Salle Street, CHICAGO, ILL.

AN experienced and thoroughly practical Street Railroad man, competent to fill any or all of the following positions: Superintendent, Secretary, Purchasing Agent, Auditor and Accountant, desires a change. Location no object. Present position combines the duties of Superintendent, Secretary, Auditor and Accountant. Would prefer position as General Manager to take hold of large failure, entire charge of operating a medium sized Road or to look after the interests of a syndicate controlling several small Roads. Remuneration whole or in part can be based on results obtained. This is a genuine and unusual opportunity to secure a first-class reliable right-hand man on easy terms; expectations are small. Correspondence or an interview is solicited. Address—

"Expert," Box 17,

No. 1692 Broadway, New York City.

## CONDUCTORS AND DRIVERS.

"The Travels of the Bontramont and Gorman Families," an elegantly illustrated book of Southern Travel, written in the form of a romance, will be mailed free to any one sending four cents in postage to

E. O. McCORMICK,

G. P. A., Monon Route, CHICAGO, ILLS.

## COFFIN, DEVOE & CO.

(F. W. DEVOE & CO., N. Y.)

COACH AND CAR COLORS, Ground in Japan,  
COLORS IN OIL,

**Fine Varnishes,**

FINE BRUSHES,

And Every Requisite for the Painting Department.

176 Randolph St., Chicago, Ill.

CORRESPONDENCE SOLICITED.



# The Street Railway Gazette.

VOL. II.

CHICAGO

OCTOBER, 1887.

NEW YORK

NO. 10

## American Cable Railway Construction.

BY AUGUSTINE W. WRIGHT.

PART I.—(Continued from page 187.)

On the same shaft carrying the drivers, heretofore mentioned, are large gears, of about the same diameter as the drivers, operated by a pinion on the engine shaft of one-third their diameter, so the engine makes three revolutions to one revolution of the drivers. V-teeth are used on all these gears, and they are four and a half pitch and 20-inch face. There are four sets of drivers for the four ropes, but one set of gears and one pair of engines operates them all. The other pair of engines are held in reserve as a spare set in case of accident. The engines for the other lines located in the McAllister engine house are simple engines, 18x48 feet, arranged to work either singly or together.

### THE STRETCHING AND TIGHTENING ARRANGEMENT.

The tension of the wire rope on all these roads is something which has to be provided for, otherwise there would not be a uniform tension maintained. Moreover the change in length, with the ordinary changes in temperature, during the day and night, of 40,000 feet of metal cable, must be also looked after.

On a hot day the cable is several feet longer than on a cool one, and this ever-varying change in length must be compensated for, and the apparatus for doing this must be automatic. The rope is furthermore continually lengthening by wear, and during the life of a rope the total stretch is about one per cent. of its total length. The method in use on this road is considered to be the best known. Of course each rope has to have a separate stretching and tension arrangement. The principal object in keeping the uniform tension is to prevent the rope slipping on the drivers, it being driven merely by friction. Behind the engines in the engine room, and in line with the driving pulleys, brick-lined excavations 165 feet long each and 5 feet wide and deep have been made, one for each cable. Over each one is a stretcher arranged for a separate cable. A description of one will serve for all. A large and heavily framed carriage, L (Fig. 20)\*, mounted on wheels and moving on tracks, is placed over the excavation. A pair of tracks, close together, is on each side, and each pair forms a rack-bar, with which a pawl on the carriage engages. These pawls prevent the carriage moving forward, as the strain of

the cable tends to make it. On top of this main carriage is a smaller one, also on rails, the rails being on main carriage.

The small or supplemental carriage carries a vertically revolving pulley, M, about 12 feet 6 inches in diameter. The cable or rope, after it passes around the main drivers of the engine, extends back around this sheave on the carriage. A very heavy weight, N, weighing about 10,000 pounds, hangs on a chain and connected with the supplemental carriage, passes over a chain wheel on the lower carriage and draws backward on the upper one, thus keeping a constant tension on the cable equal to one-half the amount of the weight, the strain being divided between the upper and lower ropes. This tension sheave prevents any slipping of the cable on the drivers, as elsewhere described.

The function of the lower carriage is to take up the permanent stretch of the rope. When it is found that the weight is settling down into the pit it is known that the cable has permanently stretched. Then the lower carriage is moved back and the pawls are dropped into the ladder formed by two T-rails with pins through the webs, forming a sort of rack bar, thus holding the lower carriage in its position. This moving of the lower carriage is accomplished readily, notwithstanding the strain of the cable, and without necessitating the slowing of the ropes or interfering in any manner with the operation of the road. A heavy tackle is hooked to the rear end of the carriage, and the tail rope or hauling part is taken to a spindle or gypsy on the end of the axle of the main sheave on the supplemental carriage. This is revolving steadily all the time, and by taking a few turns of the rope the tackle is operated by the power of the cable itself and the carriage hauled back on its rails, the pawls before described automatically engaging with the teeth or pins provided by them, thus holding the carriage at the desired point. As the lower carriage moves back the weight rises and the upper carriage remains stationary, but changes its position with relation to the lower one. That is, when the lower carriage is drawn back as far as desired, the supplemental one is at the front end of the lower one, ready again to be moved back automatically by its compensating weight. By the arrangement described 330 feet of each cable can be taken up.

THE SUTTER STREET (CABLE) R.R.

This road had been operated by horses; but in 1876 it was converted into cable. The more prominent change (from the Clay street cable road) was in the construction of

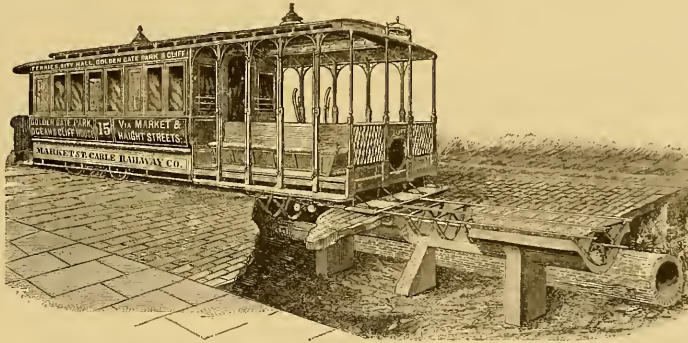

FIG. 21.—SECTION OF ROAD BED, SHOWING FOUNDATION, PIERS, TUBE, PATENT CAR, ETC.

\* See August GAZETTE, page 160.

the gripping apparatus, which was arranged so that the jaws which take and hold the cable are moved vertically, and so that the cable enters between the jaws of the grip from the side instead of from the bottom, as does the one in use by the Clay street road. These are distinguished from each other by the direction from which the cable enters the jaws. That of the Clay street entering from the bottom is called a "bottom grip," and that of the Sutter street entering from the side is called a "side grip." The side grip is so constructed that it can not be lowered like the Clay street grip to take the cable, but has a fixed position when placed on the dummy. As the cable will normally lie directly under the jaws of the grip, either the jaws or the cable must be moved sidewise to allow the cable to be brought up to a height which will allow it to enter the open jaws of the grip. As the readiest means of accomplishing the raising the cable, a sheave is so placed in the tube that the cable will be raised by it to a height corresponding to the opening of the jaws; but as without lateral movement of the grip it would strike the sheave, the rails and iron forming the slot are deflected to carry the dummy and with it the grip to one side sufficiently to pass the sheave, and immediately again the track and slot is deflected into its normal direction, thereby bringing the opening of the jaws over the cable before the cable has sagged or dropped sufficiently to prevent it entering the grip. In the latter constructions of the grip, the points at which it is supported on the car are so arranged that it may vibrate from this point laterally, so that the dummy need not be carried bodily sidewise; therefore only the irons forming the slot are deflected.

[To be continued.]

### American Street-Railway Association.

We have received very numerous inquiries concerning the forthcoming convention—especially as regards exhibits. No more information is obtainable than what may be gleaned from the following official letters, etc.

#### SECRETARY'S CIRCULAR.

BROOKLYN, N. Y., Sept. 19, 1887.

*Dear Sir:*—The Sixth Regular (Annual) Meeting of the American Street-Railway Association will be held in Parlor C of the Continental Hotel, Philadelphia, Pa., the third Wednesday in October (the 19th), 1887, beginning at 10 o'clock, A. M. The membership of the Association has reached one hundred and fifty-three companies, a list of which is inclosed.

Committees will report on some of the most important subjects concerning the street-railway business; and a meeting of unusual interest is expected. Mr. William Wharton, jr., of Philadelphia, the president of one of the members of this Association, will have three electric cars on exhibition, one of four wheels and one of eight wheels, both with storage batteries, and one of four wheels with overhead conductor.

It is hoped that delegates will, if possible, be in the city the evening previous to the meeting, so that little or no delay may be experienced in commencing the meeting promptly at the hour announced and speedily disposing of the opening business.

In order that the best accommodations at the hotel may be secured by the delegates, it is advisable that you write to the proprietors at your earliest opportunity, stating the number of delegates representing your company that will be present at the meeting, and the accommodations required. An addressed envelope is inclosed for the purpose. Board \$3 and \$4, according to location of rooms.

Presumably in consequence of the passage of the Interstate Commerce Law, the Central Traffic Association will not grant reduced rates to any organization that is not "religious, benevolent, educational or medical," and as it has decided that this association does not come under any one of the foregoing designations, there will be no special railroad rates in connection with the meeting this year.

A delegate's card is sent herewith. Will you please promptly acknowledge the receipt of this letter, returning the card duly filled out. We sincerely hope that your company will be represented at this meeting. Yours truly,

WM. J. RICHARDSON, *Secretary.*

#### EXHIBITS AT PHILADELPHIA.

The following from the president of the association may be of interest to prospective exhibitors:

PHILADELPHIA, Sept. 24, 1887.

*Dear Sir:*—Supply men will have to make exhibits in their own rooms, as no room suitable could be secured for that purpose. And several have already secured rooms for that purpose. Consent has been gotten for the exhibition of 2 or 3 street cars opposite the hotel. \* \* \* Mr. Wm. Wharton, jr., will have 3 electric cars (battery system) in full operation running on the streets, one of which will seat 40 persons. Yours truly, THOS. W. ACKLEY.

#### OFFICIAL ORGANS AND EXHIBITS.

In answer to many inquiries, both from street-railway officials and manufacturers of street-railway appliances we publish the following self-explanatory letter from National Secretary Richardson:

BROOKLYN, N. Y., Sept. 27, 1887.

*Dear Sir:*—In reply to yours of 22nd inst. inquiring if this "association has ever adopted any publication as its recognized official organ," would say that it has not; and, on the contrary, at its Third Annual Meeting, held in New York City, it took action upon the question and decided adversely in regard thereto.

As to your inquiry whether this "association proposes to hold any kind of an exhibit at the Philadelphia convention, and if not, if any is to be held under its auspices, or one that is authorized by it, in any shape or form," would say, that the only exhibit that the association proposes to hold is as fine a looking set of gentlemen and as "briny" as can be got together by any association in this country!

Sincerely yours, WM. J. RICHARDSON, *Sec.*

The subjects for discussion, with chairmen of special committees to prepare papers thereon, were stated in the September GAZETTE. We here reproduce them following the list of officers, for convenience in referring to the proceedings of the Convention, as far as they are ascertainable before hand.

#### OFFICERS.

*President:* Thomas W. Ackley (President, Thirteenth and Fifteenth Street Passenger Railway Co.), Philadelphia, Pa.

*First Vice-President:* Albert G. Clark (Vice-President, Cincinnati Street Railway Company), Cincinnati, O.

*Second Vice-President:* William H. Sinclair (President, Galveston City Railroad Company), Galveston, Texas.

*Third Vice-President:* Prentiss Cummings (President Cambridge Railroad Company), Cambridge, Mass.

*Secretary and Treasurer:* William J. Richardson (Secretary, Atlantic Avenue Railroad Company), Brooklyn, N. Y.

*Executive Committee:* President, Vice-Presidents and Julius S. Walsh, Pres., Citizens' Railway Company, St. Louis, Mo.; Henry Hurt, Pres., Washington and G. R. R. Co., Washington, D. C.; C. Densmore Wyman, V.-Pres., C. P. N. & E. R. R. Co., New York, N. Y.; A. Everett, Pres., East Cleveland Railroad Co., Cleveland, O.; S. S. Spaulding, Pres., East Side Street Railroad Co. Buffalo, N. Y.

#### SPECIAL COMMITTEES, 1887.

*Cable Motive Power:* Mr. Tom L. Johnson (Pres., Brooklyn Street Railroad Company), Cleveland, O.

*Electricity as a Motive Power:* Mr. William Wharton, jr., (Pres., Cape May and Schellenger's Landing Railroad Company), Cape May City, N. J.

*Motors other than Cable or Electric:* Mr. D. Atwood (General Supt., Cream City Railroad), Milwaukee, Wis.

*Roadway Construction:* Mr. Calvin A. Richards (Pres., Metropolitan Railroad Company), Boston, Mass.

*Street-Railway Mutual Fire Insurance:* Mr. John McGuire (Sec., City Railroad Company), Mobile, Ala.

*Practical Devices Useful in the Economical Management of Street Railroads:* Mr. De Witt C. Creiger (Supt. Chicago West Division Railway), Chicago, Ill.

Two of the above special committees have been so unfortunate as to have chairmen too busily engaged in their own businesses to devote time to prepare papers on the subjects appointed for them. But it is expected that good substitutes will turn up with interesting papers, at the convention.



## FORWARD EXHIBITORS, ETC.

The first to inform us of their intention to be represented in the way of business, at the Philadelphia Convention, were these:

MR. W. T. BUTLER, of Boston, will be there with his *Sand Box*; we heard that away back in the early days of September. And we wish the "Reliable" great success.

MR. EDWARD BEADLE, Manager of the Railway Register Manufacturing Co., New York, will make an exhibit of the different styles of *Register* manufactured by them. (MR. JOHN F. COURTNEY, Agent.)

MR. EDWARD BEADLE, 1193 Broadway, New York, will also exhibit his *Eureka Folding Mats* at the coming Convention. And "I am pleased to say to you," says he, "that I am meeting with very good success with them, and have lately filled very large orders."

THE BROOKLYN RAILWAY SUPPLY CO., 37, 39 and 44 Walworth street, Brooklyn, favor us with the following information: Probably this company will be represented at the Convention in Philadelphia by the writer. We expect to exhibit there a new *Sweeper*, medium size; also one *Walk-away Snow Plow*, and one *Boss Snow Plow*; and very likely a little light stock, such as *Stable Brooms*, etc. These machines will be set up in the Passyunk Avenue Depot, corner 13th street and Snyder avenue. \* \* \*

Very truly yours, CHAS. B. ALLYN.

THE JOHN A. ROEBLING'S SONS' CO., Trenton, N. J., cannot see that a straight piece of wire rope would amount to much, as far as looks are concerned; and so they are not likely to exhibit their wire rope for cable railways at the Convention.

THE SPRAGUE ELECTRIC RAILWAY AND MOTOR COMPANY, of 16 and 18 Broad street, New York, say, in reference to having a car for exhibition ready October 10th, "that the great pressure of business incident to filling several large and important contracts for railway work render it impossible for us to have a car ready by the date mentioned. We of course recognize the importance of the proposed gathering, and appreciate the advantages that would be derived from showing the railroad men present the merits of our system. We regret, however, that, for the reason stated, we will be unable to avail ourselves of the opportunity."

THE BROWNELL & WIGHT CAR COMPANY, St. Louis (writing September 29), say, "It is doubtful whether we will attend the Convention at Philadelphia or not. If we do go we will make an exhibition of a *Burglar Proof Fare Box*."

MR. HORACE A. KEEFER (Horace A. Keefer & Co.), Kansas City, Mo., will exhibit the *Price's Improved Fare Box*.

MESSRS. PUGH AND RUSSELL will be there in force.

THE LEWIS AND FOWLER MANUFACTURING CO., Brooklyn, have applied (by their agent, MR. L. E. ROBERTS), for half a dozen rooms on the first floor of the Continental, near the Convention Auditorium.

MESSRS. RUFUS MARTIN & CO., New York, will be represented at the Convention by Mr. R. P. Sherman, and will exhibit a variety of miscellaneous supplies.

MESSRS. A. WHITNEY & SONS, Philadelphia, are on the grounds. They do not expect to make any exhibit at the Convention, but will keep their car wheel works open and in operation, and shall be very glad to see any or all of their railway and railroad friends there, as well as at the meetings. It will be of great interest to many to see the process of manufacturing car wheels.

As we go to press, we have received a communication from Mr. H. McL. Harding, general agent of the Sprague Electric Railway and Motor Co., dated New York, October 10th, saying: "We beg to state that a representative of this company will be present at the Convention of Street Railway men to be held in Philadelphia on the 10th instant. We trust that arrangements can be made which will permit of his making some remarks on the subject of electricity as applied to street cars, should he find it advisable to do so."

## Efficiency of Cable Railways.

BY W. W. HANSCOM, M. E.

Since cable railroads have come into practical existence and successful financial operation, it has been well demonstrated that the cost of operating them is much less than roads operated by horses, and that the capacity of the same road has been much increased by changing the motive power from horses to steam by using the cable for conveying power to the cars.

While the cost of construction is an important factor, the efficiency of either system is quite as important, and is probably more discussed in comparing the relative economy than the cost of construction. When we say efficiency we mean the proportion of gross power required actually to move the cars and passengers. Steam being usually the motive power, a central station is constructed where this power is generated, and from which place it is distributed to the various cars along the road. The means by which this power can be distributed the most economically is the system most desirable, other things being equal. The systems now attracting most attention are the cable and the electric; each having advocates and advantages over the other in different respects. The cable system has secured a substantial footing from its fourteen years of use; and the electric system is having such a great number of practical investigators that no one can question but what all its advantages will soon be thoroughly demonstrated.

This article is intended to show the degree of efficiency in operation which cable roads have easily attained, and are daily showing, so that a fair standard may be known and accepted by which to measure the efficiency of the electric system. We may say that a cable road having less than one mile of double track, and transporting less than 4,000 passengers per day, is paying 10 per cent. dividends on an investment of one hundred and fifty thousand dollars. The efficiency of the power on this road for distribution to the cars is, for friction of machinery and cables, 79 per cent., and for moving cars and passengers, 21 per cent. This is much less than is expected of other systems, especially when of greater length; so that we may say that any road having the conditions as favorable for cost of construction, and having no less efficiency than the above road, can, with a travel equal to 4,000 passengers per mile of double track, per day, be made profitable.

Now, while with this showing a cable road may be profitable, the efficiency of the distribution of power on other cable roads has been and is being daily shown to be much greater. The Market Street Cable Railway in this city (San Francisco), one section of which is operated from the Valencia street engine-house, and includes the cables on Market, Valencia and Haight streets, has a length of double track of about  $6\frac{1}{4}$  miles, and in 1884 ran 44 cars.

At this time the distribution of power from this engine-house was as follows: for cables, 201 hp.; for cars and passengers, 100 hp.; total, 301 horse power; the cable requiring 66.7 per cent., and the cars and passengers 33.3 per cent. Since that time the traffic has so much increased that they often have 88 cars on this section now, and the number of passengers is doubled. This would require the power distributed as follows: cable, 201 hp.; cars and passengers, 200.12 hp.; total, 401.12 horse power. Or, in per cent., cable, 50.1 hp.; cars and passengers, 49.9 hp.; total, 100 horse power; showing that almost 50 per cent. of the gross engine power is used in the movement of cars, etc.

If we take the gross average power, and divide it by the average number of cars, we shall have the average gross power required for each car and its average number of passengers, which would be, in this case,  $401.12 \div 88 = 4.55$  horse power for each car. And it seems as if this was the simplest way, and fairest, for making a comparison of the efficiency of any two or more systems of street railway motive power. Of course there may be great difference in the comparative efficiency of the details of any system by itself; but these figures are such as are attained under favorable circumstances, and not the best that may be reached under especial conditions.

### Sand Box for Closed Cars.

In the July number of the STREET RAILWAY GAZETTE, we published an engraving and description of a Sand Box; known as "The Reliable" sand box, showing how it was applied to an open cable road car.

The engraving now presented shows how this sand box is applied to closed cars.

Comparing the two engravings\* it will be seen that in the former case, the sand box is placed under the floor of the car; in the latter it is placed on top of the floor. Its position relatively to sill and forward wheels being similar in both cases.

The mechanical arrangement is slightly different in the closed car, as will be observed and readily understood on reference to the annexed engraving.

end of a straight lever. The pressure of the foot on pin *K*, moves the lever and opens the mouth of the box thus allowing the sand or other ingredient to run; the release of pressure (taking the foot off) causes the spring to act on the oscillating incline, closing it quickly and forcibly.

The mouth of the chute is rectangular in form; there is no liability to choking or sticking.

The traverse motion of the foot pin is adjustable. By means of the screw seen in the engraving the height of *K* can be raised or lowered, and the traverse motion is increased or decreased at pleasure. This traverse motion regulates the amount of opening of the mouth of the chute, and allows more or less sand to fall.

The address of "The Reliable" Sand Box Company appears in our TRADES DIRECTORY.

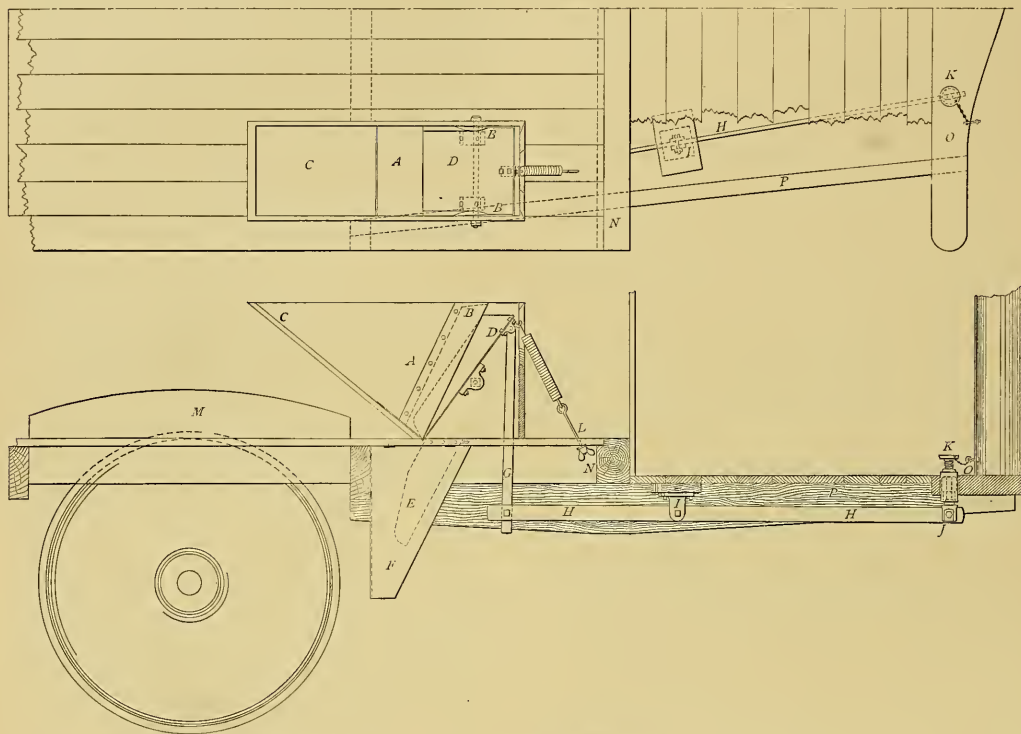

"THE RELIABLE" SAND BOX AS APPLIED TO CLOSED STREET RAILWAY CARS.

*A*, sand box complete;  
*B*, concave guards;  
*C*, fixed incline;  
*D*, oscillating incline;

*E*, sand chute;  
*F*, guard for chute;  
*G*, connecting rod;  
*H*, rocker arm;

*I*, hanger for fulcrum pin;  
*J*, spring and adjusting nut;  
*K*, foot adjusting pin;  
*L*, hook for spring;

*M*, wheel box;  
*N*, end sill of car;  
*O*, dasher foot board;  
*P*, platform timber.

This device has been found to be the best for the purpose designed. Sand (wet or dry), salt, gravel or common soil can be put into the box, and any one of these ingredients can be used at option. Indeed the box can be filled, in some cases of country travel, with sand from the road or embankment, should circumstances require an extra quantity. The operation is exceedingly simple. The foot adjusting pin *K*, is close to the driver's foot; on a slight pressure of the foot giving an inch or two of movement, the mouth at the bottom of the oscillating incline *D*, and fixed incline *C*, is opened instantaneously and the ingredient will run out on the track so long as the pin *K*, is held down.

The parts are few, simple and strong; the power and movement being obtained by the pressure of the foot on the

horse go are increasing. A few years ago, says one, steam used direct was thought to be the best means for operating street railways. At the present time this means has but few advocates. Steam street motors have substantially proved failures after what appears to have been a very fair trial. It does not follow that attempts to use steam motors for this purpose will be abandoned, but the prospects for success in that direction do not appear to be flattering, compared with either the cable or with electric motors. The race appears to be between these two, and between them the horse will be gradually crowded out. Just as the steam engine displaced horses used for pumping water and performing other service at mines, so it will, indirectly probably, displace horses on street railroads.

\* See July GAZETTE, page 137.



**A New Transfer Table.**

The accompanying illustrations show a new transfer table, invented by Mr. C. J. Langdon, of Fulton Foundry, Cleveland, O. Numbers 1 and 3 show the hub of the wheels with internal anti-friction rollers, of cold rolled steel, made to fill the hub, after it is bored to the size required. A glance at cut No. 2 will show that the weight of the table is always on the bottom rollers, giving it the easiest possible motion. The table is here shown set up and ready for service. No pit is necessary, only openings in the floor, 2" wide through which the carrying bars are connected to the transfer truck. Any old tram or T rail in tolerably fair condition can be used as a track for this table to run on. So long as the track is kept clean, the space underneath the table can be left open, or filled up with dirt or cinders. The set screws in hub of wheel covers the oil hole. The table is made in four pieces and any one of fair average ability can put them together.



FIG. 1.

**Special Correspondence.**

St. Louis, Mo., September 30, 1887.

The work on the two cables—the Olive street and the Franklin avenue—has progressed rapidly, notwithstanding the fact that the Franklin avenue line has experienced much difficulty in getting men. They had hoped to have the work all done and the cable running before the opening of the big Fair. Two weeks ago there was a fair prospect of it as there were but two of the St. Louis, Cable and Western crossings to be made, and a gap on Grand avenue to be filled. A week ago the superintendent of construction, Charles K. Dickson, announced that if they could have five days' practice before the Fair, they would run the cable cars during the Fair, traffic being very heavy at that time. They confidently expected to begin practice on Wednesday of this week. President Walsh of the Franklin avenue road stated that in case the work was not completed in time to string the cable and begin operations, the paving between the tracks would be finished as nearly as possible with the granite, and the open spaces would be covered with boards, that the horse cars might be run during the Fair week. This is now being done, the completion of the work not having been accomplished. There is no more conveniently located line leading to the Fair grounds, and the regular traffic incident to Fair week, will this year be largely increased by the presence of President and Mrs. Cleveland at the Fair. This line will be using its own tracks by Monday next though the cable will not be running before the middle of the month.

Work on the Olive street cable has extended west. At the time of the opening of the Exposition the street in front of the Exposition building was in bad condition, and just west of the Exposition it was torn up by the workmen laying the cable. At that time the Olive street cars were leaving Olive street at Thirty-fourth street and returning at Seventh, all the intervening space being in possession of the workmen. This cut the Olive street road off from most of its Exposition travel—one of its most fruitful sources of income. Just before the beginning of the Grand Army Encampment, however, the track west of the Exposition was completed for some distance, and cars again assumed operations on Olive street as far west as Twenty-third street. Mr. Maffitt expects to complete the road by November 1st, and have it running by the time snow falls.

The Cable & Western road has been singularly unfortunate, in many respects, in its pyrotechnic enterprise. On the opening night of season of the Fall of Pompeii, at the

cable amphitheater there were two accidents on the narrow gauge road—the steam division of the Cable & Western—which completely blockaded the track and the entertainment had to be postponed. On the second night a slight accident below the platform delayed the trains which were to take the 7,000 people home. A gate-keeper, disobeying instructions, left open the gates, and the crowd swarmed onto the track and filled cars so completely that when an effort was made to back the train up the Y in front of the platform in order to reverse it, it was declared impracticable, and after much delay, it was found necessary to back the train down to the city, on the wrong track. This caused much confusion and delay to the other trains all of which occasioned great complaint. Matters were set right, though, by the next performance and everything was soon running smoothly. No sooner, however, had the mechanical difficulties been overcome, than the weather interfered to prevent the performance which, being in the open air, can only be produced under clear skies. During almost the whole of the Encampment week, which should have been the best week of the season, it has rained steadily and the company has lost a large amount of prospective profits, if nothing more. The display is exceedingly fine, and would certainly attract throngs of people but for the inclement weather.

The Brush motor for the Washington avenue line arrived from Cleveland about a month ago, and was sent immediately to Brownell & Wight's car shops to be fitted to the car which had been prepared for it. It was discovered on its arrival that no regulator had been sent with it, and the Brush company was telegraphed at once.

The car was promised within a week, but one delay after another has occurred and it is still unfinished. This interferes greatly with the company's electric experiments. The Sprague motor has not been heard from recently, but it is thought it will be here early in the coming

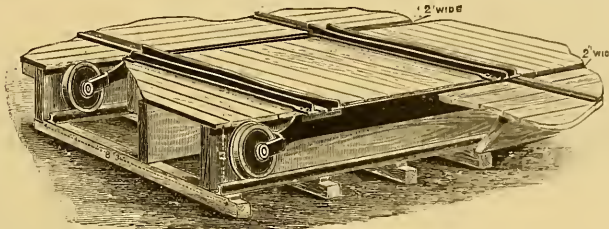

FIG. 2.

month. A telegram received two weeks ago announced that it had been successfully tried in Boston.

The question of the stoppage of the street cars has been more or less agitated in the last two weeks among street railway men. A local paper endeavored to work up sentiment in favor of the establishment of regular stations on each line, with the idea of expediting travel. It was proposed to establish these station two or three squares apart, no stoppages to be made between these points; but the proposition did not meet with much favor among railroad men. Some time ago Captain McCulloch of the Washington avenue line rescinded an order issued by his predecessor, Mr. Maxon, that all cars should stop only at the far crossings. He renewed the order, however, finding that the stoppages between crossings demoralized his schedule.

G. G. B.

"THE Horse must go," echoes our contemporary, the *American Machinist*. "The opinion that some other means than horses must be employed for moving street cars is rapidly gaining ground. Cars moved by horses present a spectacle too unmechanical to be tolerated in these times, when the power of steam is taking the place of muscular exertion in almost everything. Better speed is demanded on street roads, and it has become a case of absolute cruelty to animals to compel horses to perform the service required. The life of a horse in such service is but a few years at the most. Fortunately, the demands for better service are such as leave horses out of the question, and, undoubtedly, in a few years they will be out of the question in point of economy."

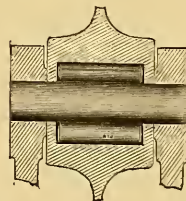

FIG. 3.

### The Ries Underground Conduit.

Of all the recent applications of electricity now undergoing the process of practical development, there is perhaps none that is at present watched with greater interest, says the *Western Electrician*, or absorbs a larger share of the public attention, than the employment of this force as a motive power for street railways; nor is there any field in which this most flexible power can be more profitably employed, or in which it promises to produce a more rapid and noteworthy change for the better.

We illustrate an electric railway conduit that forms the subject of a patent granted September 20th to Elias E. Ries, of Baltimore, Md., which is said to be admirably adapted to the requirements of electric street railways in large cities. This conduit embodies a number of novel features of practical value and bears evidence of having received sound mechanical treatment in its design and construction. One of the peculiarities of this form of conduit is the provision made for carrying and distributing electric wires, cables and other conductors, the space at both sides of the conduit proper being utilized for this purpose.

In the accompanying illustrations, fig. 1 is a perspective view of the conduit, partially exposed to show the construction and arrangement. Fig. 2 is a form of bracket for a double track railway, cast in a single piece, and having flanged openings for the reception of wire ducts, pneumatic tubes, etc. This view also shows the conduit channel with its conductors, and the arrangement of the track and slot rails. Fig. 3 shows an ordinary cable railway conduit provided with electric railway conductors, arranged in such a manner (with respect to the cables and grips) that the conduit may be utilized simultaneously by both systems. This construction is of importance where an electric railway is required to turn into a street already occupied by a cable conduit.

Referring to fig. 1, it will be seen that the supporting brackets are placed in a shallow trench at intervals of four feet apart, and rest upon cross ties of concrete in order to insure a solid foundation. These brackets have a flanged central spring, 6, forming the conduit channel, and on their upper surface are recesses for the reception of the track and slot rails, respectively, as shown. The track rails are preferably of the girder type, and are self-supporting between the brackets, and they are removably secured in place by a locking plate, 16, so as to permit removal without disturbing the conduit structure. The width of the conduit slot, which in this system is half an inch, is regulated by means of the adjustable tie bolts, 7, in the usual manner. The construction is such, however, that no perceptible variation in the width of the slot, or in its distance from the rails, is possible, the entire conduit being as firmly and solidly united as if it were one single piece. The walls of the conduit opening are provided with undercut recesses that serve to hold insulators, 12, which are secured in place as the construction of the conduit progresses. Within these insulators, the supply conductors, 13, are afterwards inserted, these conductors being perfectly free to expand and contract by reason of the slip joint support thus formed, while at the same time they are

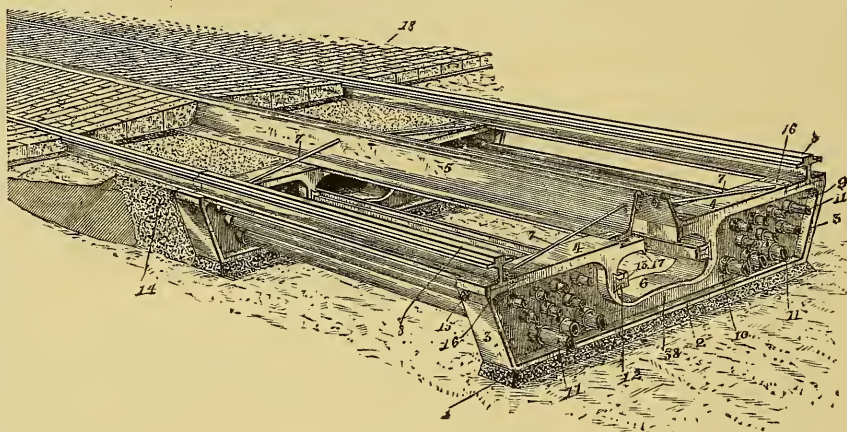

FIG. 1.—RIES COMBINATION CONDUIT.

sufficiently rigid to bear the pressure of the current-collecting wheels that travel in a horizontal position between the two conductors. The conduit channel is provided with drainage outlets at proper intervals, and the brackets have depending ribs, 17, that serve to deflect any water that may enter the conduit slot and cause it to drop clear of the conductors, 13.

It will be noticed that the conduit brackets are formed with a series of flanged openings, 10, at both sides of the conduit channel. These openings serve as a support for paper tubes or ducts, that are prepared in a special manner and impregnated with asphaltum to render them moisture and gas proof. These tubes extend from the center of one bracket to the center of the next so as to form practically continuous tubes, and are hermetically sealed with liquid asphalt poured around a joint of special construction formed upon their ends. When the tubes between two or more brackets are in place the space between the brackets and around the conduit channel is filled with a suitable cement or concrete, which securely embeds and protects the tubes and serves as a support for the paving blocks, thus making not only an economical and permanent conduit structure, but forming a smooth, solid and durable road-bed and street surface. At intervals of one or two blocks manholes are provided for gaining access to the ducts or

tubes, and for making connection between the conductors or wires carried in the main conduit and those of branch or distributing conduits at street intersections.

Owing to the novel form of current collectors employed in the Ries electric railway system, the depth of conduit channel necessary is but six inches, and the entire depth of conduit shown in figs. 1 and 2, measured from the street surface, does not exceed eighteen inches, thereby saving the expense and obviating the various underground obstructions common to deeper excavation. And it will be apparent that the wire ducts are not essential to the conduit, but may be omitted in localities where they are not required without interfering with the general construction shown. It is perhaps worthy of mention that two of the twenty-three claims obtained on this patent practically secure to the Ries system a monopoly of the operation of both electric and cable railways from the same conduit, and also the conversion of a cable into an electric railway, a change that by means of this system is rendered entirely feasible.

ELECTRICITY direct from fuel is one of Mr. Edison's latest problems; he has been at work a considerable time generating electricity directly from the fuel without first converting it into power in the engine. A paper prepared by him has been published recently, wherein is described an apparatus for this purpose, which he calls the pyromagnetic dynamo.



**Electric Welding and Tempering Metals.**

“Be it known that Elias F. Ries, a citizen of the United States, residing at Baltimore, in the State of Maryland, has invented certain new and useful improvements in electric welding and tempering metals.” So says the patent just

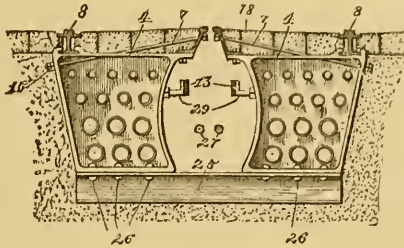

FIG. 3.—RIES COMBINATION CONDUIT.

issued. The invention relates to a new and improved method and apparatus for effecting the welding and tempering of joints between metals by the regulation of the heating effect of an electric current, and the immediate application of a tempering bath or compound. It will be obvious to those skilled in the art to which this invention appertains that the juncture formed between any two like metals of the same cross-section by means of the heat developed in the ratio of the square of the flowing electric current at the point of union or contact will be left in an annealed or softened state. Take, for instance, two sections of steel railroad-rails and effect a fusion between two adjacent extremities thereof by means of an electric current. Manifestly the joint formed will not correspond to the normal hardened condition of the other portions of said sections, and therefore it will be comparatively incapable of strength and durability. Furthermore, in fusing a joint between two steel rails, as before cited, if the current of necessarily low potential and having heavy heating effect should be suddenly applied with its full strength, the end of each rail will immediately assume a molten state and a joint will be formed; but such sudden application will destroy the tempering properties of the steel beyond redemption or subsequent restoration by any tempering process. Consequently, although such process may be used to advantage where a mere union is all that is required, it can not be employed successfully for welding tempered or hardened metals, such as steel, without first gradually regulating the strength of the current permitted to pass through the adjacent ends of the rails, so that the said ends barely attain a melting temperature, and then applying an immediate and effective tempering means. Again, inasmuch as the apparatus necessary for fusing hardened metals by the conversion of electrical energy into heat precludes the employment of ordinary tempering means, and as this difficulty is even more increased in the particular

special construction; and fourth, to adapt this hereinbefore-mentioned system for advantageous use in laying railway tracks in continuous sections.

This latest invention of Mr. Ries is of special interest to street railway men, so far as it provides an improved method of track laying, wherein rail sections may be permanently joined and laid end to end *in situ*, thereby furnishing an almost perfect road-bed, free from rail joints and their attendant evils—chairs, fish plates, and nut-locks—that have always been the fruitful cause of accidents, and have likewise been the chief source of expense for repairs and maintenance of way and rolling stock. By this method, and by means of apparatus forming the subject of other patents still pending before the patent office, the welded portions of the rails are rendered even stronger and tougher than the rest of the rail, so that any amount of pounding or strain can not affect the junction, and the operation of welding and tempering takes place much faster and can be effected at less expense, we are assured, than the laying of the ordinary joints. To provide for expansion and contraction, a special form of slip joint has been devised, of which there are ordinarily four to the mile. The section of rail between two joints is firmly spiked at its central portion, and expands in both directions. This joint is so arranged as to give a solid support to the wheels while passing, so that practically the entire track is one smooth, continuous way. Whether applied to steam or street railways, this construction will contribute very materially to the comfort of traveling, to the life of the roadway and rolling stock, and to the economy and general superiority of the permanent way.

**Edison's Electro-Motograph.**

About the first instance in which the electric current was directly employed to increase the amount of friction between the two rubbing surfaces was in Edison's electro-motograph. In this instrument, the variations in the strength of telephonic current caused corresponding variation in friction between a revolving cylinder of moistened chalk and the free end of an adjustable contact arm whose opposite extremity was attached to the diaphragm of the receiving telephone. It has been discovered in the operation of electric railroads, in which the track-rails form part of the circuit, that a considerable increase in the tractive adhesion of the driving-wheels is manifested, due to the passage of the return current from the wheels into the track. Experiments have shown that the co-efficient of friction between two conducting surfaces is very much increased by the passage therethrough of the electric current of low electro-motive force and a large volume. This is especially noticeable between two rolling surfaces in peripheral contact with each other. This increase in frictional adhesion is principally noticeable in iron, steel, and other metallic bodies, and is probably due to the molecular change in the conducting substances at their point of contact, caused by the heat developed at that point. This heat is not ordinarily perceptible. It becomes apparent only when the current strength is largely augmented.

It is therefore possible that a portion of this tractive adhesion is due directly to the current itself, aside from its heating effect. In a model car and track arranged to show the operation of this system, the current is one of alternating

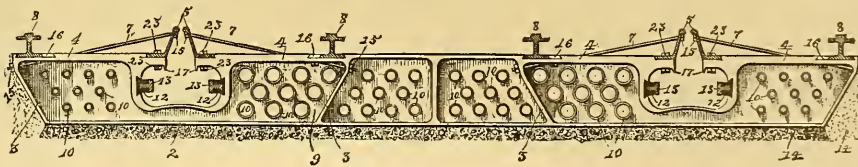

FIG. 2.—RIES COMBINATION CONDUIT.

adaptation of this welding and tempering process, this invention has for its object, first, to provide for the regulation of the heating effect of the electric current both before and after the formation of the joint; second, to furnish a suitable tempering compound and improved means for the immediate application of same after fusion; third, to convert a primary current of high potential and small quantity into a current of low potential and heavy heating effect by means of secondary generators or transformers and other apparatus of

polarity. It is converted by the transformer into one having the required volume. In practice, the electro-motive force would be about half a volt.—E.v.

THE entire motive power of the world is given by the bureau of statistics in Berlin. The force equivalent to the working steam engines represents in the United States is 7,500,000 horse power, in England 7,000,000 horse power, in Germany 4,500,000, and in France 3,000,000.

## Warming and Ventilating Boston Cars.

The car stove did go, but it will soon be sneaking back again. *Boston Globe.*

There is no difficulty about doing so, many suppose, and to a certain degree they are right in their supposition. It is quite easy to cut out one seat and place a small, neat cylindrical stove in the opening, carrying the smoke pipe up through the roof of the car. A box of coal put under the seat serves as a coal bin from which the fuel is taken when needed. As for ventilation there are two doors, side windows, and adjustable swivel windows in the upper part of the car. No trouble about warming the car and getting fresh air. But these simple means for warming and ventilation have given street railway companies no little trouble. Indeed every winter brings its complaints from passengers, its growls from Grumbler & Co., about uncomfortable cars. Listen, reader. Some are too warm when they sit near the stove, in front of it or on either side of it. Some are too cold when they sit near the door. The car gets too warm, doors or windows are thrown open, then, draughts precipitate themselves with rushing chilling currents and "catching colds" is in order. The windows and doors are kept closed and then the air gets stifling and impure. Old people want warmth; thinly-clad people want warmth; passengers who have to travel four or five miles through a snow-storm or in a freezing atmosphere, want warmth. The industrious mechanics and the poor working girls who travel at early morning to their duties and return only during dark evening hours, want warmth—in short—all who travel in street railway cars want warmth, light and pure air. Do they get them?

For some time past this subject has received the attention of railway companies, and also of car-builders, engineers and inventors, who are all aware of the frequent discomforts experienced in street cars during the winter season.

The street cars in Boston had no warming apparatus last winter—not even a small stove. Why? In answer to many enquiries we have made relative to the non warming of the cars in this city, the very discomforts we have referred to were named as excellent reasons for not putting in stoves. Other answers were loud in condemnation of the "penuriousness" of the companies who "are too stingy to go to the expense of a little stove and a box full of coal for each car." "They know," said a worthy citizen, "that most of us are compelled to use the cars in order to go to and return from our business, and that we cannot help ourselves, and therefore, in cold weather we have to grin and bear it. Now in our crowded streets we have a great many stoppages,—sometimes long and tedious ones at that,—but many get out and walk rather than shiver in a horse car."

We are not of those who think the street car companies act penuriously. It must be remembered that there are not a few who prefer to ride in a cool car with fresh air, rather than get heated into perspiration and go out suddenly into a cold atmosphere. Stoves are not the only means for warming cars. As a matter of expense they are the cheapest and simplest, and some will add, the nastiest means for the purpose, but there are other devices and apparatus and systems that can be used for obtaining a pure warm air in a car. (Cline's system has become favorable in Chicago and elsewhere, and deserves universal attention.)

The Boston companies, however, as a starter, might put in stoves of a pattern similar to that used in New York and Brooklyn, without incurring great outlay or risking any experimental system of a dubious character. With proper care and attention on the part of conductors, a car may be kept comfortably warm with an ordinary cylindrical stove that takes up but little room and needs only regular and intelligent attention. We opine that this subject of warming street cars during the coming winter will receive serious attention from several companies who desire to do justly, and meet as far as possible the wishes of the public.

Would not a limited number of warmed cars be a success on every road during the winter? Past experience seems to answer—Yes. The tone of the public mind would then soon be ascertained, and *pro* or *con* quickly reached.

## Increasing Tractive Adhesion of Electric Motors.

Mr. Elias E. Ries, the Baltimore electrician, whose "combination" system was fully explained in the August GAZETTE, read a paper before the recent meeting of the American Association for the Advancement of Science, in New York, showing a method of increasing the traction of railway motors, which is said to be peculiarly adapted for street railways, and is intended to be used in connection with a system of electric railways "now being developed" by Mr. Ries.

"In this system electro-magnetism provides the means whereby the increase in tractive adhesion is produced, and this result is attained in an entirely novel manner. Several attempts have heretofore been made to utilize magnetism for this purpose, but apparently without success, chiefly because of the crude and imperfect manner in which most of these attempts have been carried out. The present system owes its efficiency to the formation of a complete and constantly closed magnetic circuit moving with the vehicle and completed through the two driving axles, wheels, and that portion of the track rails lying between the two pairs of wheels. \* \* \* The helices on both axles are so connected that when energized they induce magnetic lines of force that flow in the same direction through the magnetic circuit. There are therefore four points at which the circuit is maintained closed by the rolling wheels, and as the resistance to the flow of the lines of force is greatest at these points, the magnetic saturation there is most intense and produces the most effective results just where it is most required. \* \* \* The amount of current required to obtain this increased adhesion in practice is extremely small. The system is very simple as well as inexpensive, and the amount of traction secured is entirely within the control of the motor-man, as in the electric system. The revolution of the driving axles and wheels are not interfered with in the slightest, the former because the axle boxes are outside the path of the lines of force, and the latter because each wheel practically forms a single pole piece and in revolving presents a continuously new point of contact of the same polarity to the rail, the flow of the lines of force being most intense through the lower half of the wheels and on a perpendicular line connecting the centre of the axle with the rail. In winter all that is necessary is to provide each motor car with a suitable brush for cleaning the track rails sufficiently to enable the wheels to make good contact therewith, and any tendency to slipping or skidding may be effectually checked. By this means it is easily possible to increase the tractive adhesion of an ordinary railway motor from 50 to 100 per cent. without any increase in the load or weight upon the track, for it must be remembered that even that portion of the increased friction due to direct attraction does not increase the weight upon the roadbed as this attraction is mutual between the wheels and track rails; and if this car and track were placed upon a scale and the circuit closed, it would not weigh a single ounce more than with the circuit open. And it is obvious that this increase in friction between two moving surfaces can also be applied to *check* as well as augment the tractive power of a car or train of cars; instead of opening the traction circuit, the current flowing through the helices is simply reversed by means of the pole changing switch, whereupon the axles are magnetized in the opposite direction and the brake shoes are instantly drawn to the wheels with a very great pressure, as the current in the helices and brake coil now assist each other in setting up a very strong magnetic flow, sufficient to bring the motor car almost to an instant stop, if desired.

"Experiments have also been and are still being made with the object of increasing friction by means of permanent magnetism, and also with a view to *diminishing* the friction of revolving and other moving surfaces, the results of which will probably form the subject-matter of a subsequent paper."

After taking all these theoretical improvements into account, it may be worth knowing what are the calculated expenses of the "new electric railway system" described in the



STREET RAILWAY GAZETTE for August with extracts from the Ries electric railway pamphlet.

By adding schedules A and B, we will have excerpted the main portions of this pamphlet, for an advance copy of which we return thanks to "The Ries Electric Railway System," this being the *nom de plume* of the capitalists at back there-

of. (Mr. Albert H. Henderson, Room 27, Chamber of Commerce, Baltimore, Md., U. S. A., is the business manager.) We observe, however, that these interesting comparative statistics show the cost of "other electric railway systems" much higher than the estimates of some of the electric railway builders who have already "won their spurs."

THE RIES ELECTRIC RAILWAY SYSTEM. (Schedule A.)

Estimated Cost of Construction and Equipment, with Comparative Tables of other Systems.

NOTE.—These estimates are all calculated for a double-track city street railway for heavy traffic, 5 miles in length each way, operating 40 cars, at an average speed of 6 miles an hour, 16 full running hours per day, at 2½ minutes headway. Maximum grade, 6 ft. in 100. Smallest curve, 40 ft. radius.

CONSTRUCTION AND EQUIPMENT.	RIES SYSTEM.		OTHER ELECTRIC RAILWAY SYSTEMS.*			Cable Conduit Systems.	Horse Railway Lines.
	Average Cost per Mile. <sup>b</sup>	Total for Ten Miles	Overhead Conductors <sup>d</sup>	Underground Conductors.	Secondary Battery.		
Underground Conduit, complete (10 miles).....	\$15,000	\$150,000 <sup>e1</sup>	\$75,000 <sup>d1</sup>	\$200,000	\$-----	\$45,000	\$-----
Track Rails and Road-bed.....	7,000	70,000	70,000	70,000	70,000	42,000	70,000
Cars, 16 foot bodies, at \$900.....(40)	3,600	36,000	36,000	36,000	40,000 <sup>f1</sup>	40,000	36,000
Motors and Attachments, complete.....(40)	3,200	32,200 <sup>e2</sup>	36,000	49,000	40,000	-----	-----
Secondary Battery Equipment, complete.....	1,800	18,000 <sup>e3</sup>	-----	-----	80,000 <sup>f2</sup>	-----	-----
Steam-power Plant, complete.....	1,200	12,000	17,500	20,000 <sup>e1</sup>	22,500 <sup>f3</sup>	28,000	-----
Generating Dynamos, etc.....	900	9,000 <sup>e1</sup>	18,000	20,000 <sup>e2</sup>	23,000 <sup>f4</sup>	-----	-----
Generating Station, Car Buildings, etc.....	1,000	10,000	12,500	12,500	17,500	20,000	50,000
Engineering Fees.....	1,000	10,000	10,000	10,000	5,000	15,000	5,000
Miscellaneous and Contingencies.....	500	5,000	5,000	5,000	5,000	10,000	5,000
Other Operating Machinery, Sheaves, etc.....	-----	-----	-----	-----	-----	12,500	-----
Curves for Cable Road (4).....	-----	-----	-----	-----	-----	7,500	-----
Horses (400) at \$150, including Harness.....	-----	-----	-----	-----	-----	-----	4 <sup>h</sup> 60,000
<b>Total Cost of Construction and Equipment.....</b>	<b>\$35,200</b>	<b>\$352,000</b>	<b>\$280,000</b>	<b>\$413,500</b>	<b>\$303,000</b>	<b>\$633,000</b>	<b>\$226,000</b>

\*NOTE.—The several systems for which comparative figures are here given have been selected from among those at present known, as being the most economical and practicable, in construction and operation, in their respective classes and the prices quoted under each have been placed at the lowest figures consistent with proper workmanship and service.

REMARKS.—*b*. Estimated on a 10-mile basis, single track. *e1*. This price is for the shallow Conduit System, double Conductor; for Combined Electric Railway, Roadbed and Wire Conduit add \$15,000 per mile to first cost, and subtract \$12,500 per year for income. *e2*. 40 Ries Double-current Motors at \$800. *e3*. Single permanent set of 2 hours' capacity for each car, at \$450 per set. *e4*. Three Ries Double Armature Generators, at \$3,000, capacity 150 H.P. each, one in reserve. *d*. Not adapted, except in special cases, for cities of over 10,000 population. *d1*. Estimated for a Double Conductor System on standard supports. *e1, e2*. Excess in plant necessary due to more or less imperfect methods of generation, transmission and reconversion, and losses due to leakage. *f1*. \$100 additional per car for battery accommodations. *f2*. Two sets of 8 hours running capacity for each car, at \$1,000 per set, with fittings. *f3, f4*. This cost may be somewhat reduced by running the plant 24 hours per day instead of 16; the coal consumption and attendance, however (see Schedule B) will be the same in either case. *g1*. Includes grip and attachments. *h1*. Includes stables. *h2*. Allowing 10 horses per car.

THE RIES ELECTRIC RAILWAY SYSTEM. (Schedule B.)

Estimated Annual and Daily Operating Expenses, With Comparative Tables of Other Systems.

RUNNING EXPENSES AND MAINTENANCE.	RIES SYSTEM.		OTHER ELECTRIC RAILWAY SYSTEMS.			Cable Conduit System.	Horse Railway Lines.
	Average per Day.	Cost per Annum.	Overhead Conductors.	Underground Conductors.	Secondary Battery.		
Coal, at \$2.50 per ton.....	\$10.00 <sup>b1</sup>	\$3,650 <sup>e1</sup>	\$6,844 <sup>d1</sup>	\$7,756 <sup>e1</sup>	\$9,125 <sup>f1</sup>	\$11,406 <sup>g1</sup>	\$-----
Engineer \$2.50 and Assistant \$1.50.....	4.00	1,460	1,460	1,460	1,460	1,460	-----
Fireman, at \$1.50.....	3.00	1,095	1,095	1,095	1,642	1,642	-----
Additional Help at Generating Station.....	-----	-----	-----	-----	1,642	3,284 <sup>e2</sup>	1,642
Oil, Waste, etc.....	2.75	1,004	2,225	1,750	1,004	4,800	-----
Renewal of Battery Plates and Wire Cable.....	3.42	1,250	-----	-----	12,500 <sup>f2</sup>	13,200	-----
Other Repairs and Maintenance.....	28.93	10,560	11,200	16,540	15,150	25,320	9,040
Feeding, Replacing and Caring for Horses at \$215 per year.....	-----	-----	-----	-----	-----	-----	86,000
Entire Operating Expenses per Annum.....	\$52.10 <sup>b2</sup>	\$19,019	\$22,824	\$28,601	\$42,523	\$61,112	\$96,682
Interest at 6 per cent. on Plant, etc.....	58.42	21,320	16,800	24,510	18,180	37,980	13,560
<b>Total Cost per Year, with Interest.....</b>	<b>\$110.52<sup>b2</sup></b>	<b>\$40,339</b>	<b>\$39,624</b>	<b>\$53,111</b>	<b>\$60,703</b>	<b>\$99,092</b>	<b>\$110,242</b>
Total Cost of Operating 40 Cars, per day, including interest.....		\$110.52	\$108.56	\$146.33	\$166.58	\$271.48	\$302.03
Cost of Operating 40 Cars per day, without interest.....		52.10	62.53	78.36	116.50	167.43	267.62
Total Cost per Car, per day.....		2.76	2.71	3.66	4.16	6.78	7.55
Actual Cost of Operating each Car, per day (90 miles each) <i>a1</i> .....		1.30	1.56	1.96	2.91	4.18	6.69
Actual Cost per Car, per Round trip of 10 miles (9 trips daily).....		.144	.173	.217	.323	.464	.743
Total Cost per Car mile, including interest.....		.031	.030	.041	.046	.075	.084
Actual Cost per Car mile, exclusive of interest.....		.014	.017	.022	.032	.046	.074

REMARKS.—*a*. Exclusive of official salaries and pay of drivers and conductors. *a1*. The cost per day here given is on the assumption that all cars are kept running at 2½ minutes headway for 16 hours per day under full power. It can safely be estimated that no more than two-thirds of the power given is ever used on an average through the day, and this will reduce cost of coal consumed by one-third. The cost of animal power (horses) has been given for existing conditions, and not on the 90 mile run basis. *b1*. This small amount of coal consumed (4 tons) is due to the high efficiency of the double armature generators used, the great economy in the transmission of current peculiar to this system, and to the large saving in power effected by the combination in this system of the line current and battery. *b2*. Per day. *c1*. See *b1*. *d1*. 7½ tons per day. *e1*. 8½ tons daily; excess due to leakage and imperfect transmission. *f1*. 10 tons per day, incurred because of 20 per cent. loss of the generated current in conversion, the greatly increased weight of the motor-cars or load to be moved, the smaller economy of the low potential current used, and the lower net efficiency of the charging machinery. *f2*. Life of positive plates estimated at 2½ years; life of remainder of battery (included under maintenance) at 10 years. *g1*. 12½ tons per day, due to power lost in driving the cable and machinery, and in overcoming friction of sheaves and curves. *g2*. Does not include trackmen and oilers.

The  
**Street Railway**  
Gazette.

	Annual Subscription (including Postage).	Per Copy.
United States, Canada.....	\$2.00.	20c.
Great Britain, Ireland, India, Australia.....	10s.	11d.
Germany.....	9mk. 75 pf.	89pf.
France, Belgium, Switzerland.....	11fr. 95c.	Fr 1.10.
Spain.....	11rs. 95c.	Ps 1.10.
Austria, Holland.....	5d. 74c.	53s.
Italy.....	12 lire.	1½ lra.
Venezuela.....	12 bolivars.	1½ bol.
Mexico.....	\$2.96.	30c.
<i>Trans. Subs. in Argentine Republic, 2½ pesos; Brazil, 4 milreis; Turkey, 54 piasters</i>		

Registered Cable Address—TRAM, CHICAGO.

PUBLISHERS:

THE WRIGHT-MONROE COMPANY.

P. G. Monroe, - - - - - President.  
E. V. Cavell, - - - - - Secretary.  
S. L. K. Monroe, - - - - - Treasurer.

GENERAL OFFICES:

CHICAGO, - - - NEW YORK, - - - BOSTON.

CHICAGO:  
9 LAKESIDE BUILDING.

William Hughes, - - - - - Editor.  
Edward J. Lawless, - - - - - Associate Editor.

NEW YORK:  
181 BROADWAY.

Henry C. Lockwood, - - - Resident Editor and Manager.

BOSTON:

19 TREMONT ROW.

T. P. Pemberton, - - - Resident Editor and Manager.

EUROPEAN OFFICE:

LONDON: W. S. G. Baker, Jr., (care Brown, Shipley & Co.), Res. Mgr.

BRANCH OFFICES:

ATLANTA, Ga.: Chamber of Commerce Bldg., Wm. Minnigerode, Mgr.  
SAN FRANCISCO, Cal.; 1222 Bush St.,—G. W. Fairchild, Manager.

CANADIAN AGENCY:

TORONTO: 53 Magill Street,—Thomas Henry, Manager.

A LEGAL decision of considerable importance has been rendered at Kansas City, by Judge Gill, in dismissing the injunction brought against the Metropolitan street railway Co. by J. R. Lockwood, of the United States Wind Engine company, and other property holders, on the narrow portion of Twelfth street, between Mulberry and Hickory streets. The judge said: "When parties dedicate lands for a public street, the city can grant all privileges which it may see fit, the same being customary to a public street; street railways are proper adjuncts to public streets; further, the dedication of lands for public purposes is a release by the dedicator for all damages which may be incurred by his property abutting on the same through the use of the same for the public." This decision sets at variance the numerous compromises which have been made on the same question. It cost the Kansas City Cable Railway company \$11,000 to satisfy the Woodland avenue property owners when the extension was made at that point. If this decision holds, it will also be a barrier to other damage suits of a similar character. The matter will probably be carried to the higher courts.

"The electric motor line company are having some trouble about getting their electric machinery to work. There seems to be some doubt whether the system will be a success." So we are informed, as we go press, by a correspondent at Wichita, Kansas. We have no opportunity to ascertain further particulars. We may safely conclude it is not the Daft System (on Central ave.), as stated in our pointers; that will not be ready until the end of November; it is that other concern, no doubt. "The doubts on

the question are so strong that Mr. J. O. Davidson has asked the council to let him run a steam motor over the line instead of an electric motor. It seems probable that there will be some trouble about getting a steam motor instead of electric. Some of the council speak rather unfavorable of the change. They don't seem particularly mashed on the steam motor. Another communication gives more details, and expresses a desire for a cable railway. It says: "President J. Oak Davidson, despairing of satisfactory work of the electric motors on the Market street and Riverside line, is contemplating a cable line. The stationary engine, dynamo and machinery generating the electric power has been in place on the west side for some weeks; the wires have been stretched, but still the beautiful little motor's performances lack much of being satisfactory. It skips out with its complement of passenger coaches in a lively manner for a little way, but when an attempt is made to have it cover the same track back there is a failure. The inventor or proprietor has spent no little money in attempting to make good his guaranty. For a few days a steam motor belonging to the Valley Center line has been working up and down the road. Riverside, and in fact Market street and the people along the entire line would be pleased if a cable line should be put in. No street transportation yet invented or tried gives such satisfaction as the cable lines. Steam motors, horse power, elevated railways and electric lines, in popularity do not hold a candle to the cable service, and we hope that Mr. Davidson's desires may be realized." So says our correspondent. But we would suggest that President Davidson had better wait to see the performance of the Daft electric motor; or try the Van Depoele, Sprague or Bentley-Knight systems, which are no longer mere experiments.

CABLE Railways have received a couple of severe "shocks" since our last issue. On the other hand, the good endless wire rope has found new advocates in various quarters. The mishaps occurred at Kansas City and Cincinnati. In the first place—"the Chicago of the West," as Kansas City has been called—the cable of the Ninth street line caught in a pulley at Woodland avenue. This strain thus brought to bear on the great wheel around which the cable runs at the foot of the incline at Union avenue, caused the braces to give way and the wheel was pulled out of position. The machinery was stopped and the many passengers in the various trains were forced to walk to their destinations, and operations were delayed several days. The other hitch—at Cincinnati—occurred October 2d, and created considerable excitement. A new cable had been put on the lower division of the Walnut Hills cable road on Saturday. On Sunday evening there was an extraordinary amount of travel. The warm weather permitted the cable to expand and lengthen, instead of (as in cold weather) contracting and shortening it. And, third, there was a temporary blockade on the hill, at the end of which two thirds of the cars, densely crowded, started down the hill with no balancing weight coming up on the other side. The result of these conditions was to throw an excessive "slack" in front of the down-coming cars, and that slack became twisted, for a length of some thirty feet, into the shape of a cork-screw. When Car No. 64, after loosening its grip and before fastening it again, ran against this distorted piece of slack, the twisted cable could not pass through the grip, but caught its edges and severed some strands of the cable, which so wrapped themselves about the jaws of the grip that it was beyond the power of the gripman to loosen the hold upon the cable. So the car sped ahead and collided with other cars, which then ran wild for several blocks, and until the machinery was stopped. One of the winding drums was broken, and many people were frightened, and two women that jumped off the car were slightly hurt. President Kerper lost no time in remedying the evil, and proceeded to have on this cable road, which is 20,000 feet long, 400 telegraph boxes at very short intervals, of a character resembling the District Messenger call-box, only with six distinct signals varying as follows: "Stop Engine," "Grip Broke," "Car Off," &c. This is expected to meet and prevent any similar accident.



## President Kerper Defeats the K. of L.

A strike was recently inaugurated along the lines of the Mount Adams & Eden Park Inclined railway of Cincinnati, of which the Geo. B. Kerper is president, and culminated in a decided victory for the operating company as against the Knights of Labor.

The primary cause was the refusal of President Kerper to reinstate two employees, Fallon and Wilson, who had been discharged for disobedience of orders.

Mr. Kerper held his first conference with them, through their committee, on Friday, September 16th, when he undoubtedly convinced them that the circumstances warranted his action in the premises. Some of the disturbing element, however, seemed to think that if they were to die at all, they might just as well "die now." Mr. Kerper declined most positively to reinstate the two discharged employees, and informed the committee that he intended to settle the question as to who was running the road once and for all, and that sooner than submit to the dictation of his employees, he would discharge every single man in his employ, and fill the vacancies with other men. It was agreed, however, that cars should be run until 8 o'clock that evening, when he would again take under consideration any statement that the committee chose to lay before him. In conformance with this arrangement, a second meeting was had, but no compromise was effected. Negotiations were had on Saturday until Mr. Kerper was informed by J. J. Hoffman, chairman of the committee, that the men had already decided to have a strike, whether they were right or wrong, whereupon he issued the following manifesto through the *Commercial-Gazette*:

MR. KERPER'S STATEMENT.

CINCINNATI, September 17, 1887.

"I desire to say to the people of Walnut Hills and our patrons of the Eden Park and Walnut Hills Cable line, that the entire trouble originated from the discharge of two employees for good cause. Friday a committee of the employees called on me, and I convinced them that the men were in the wrong. I agreed at a later hour to meet the committee, the men and the witnesses and show them the evidence on which the men were discharged. After this agreement was made, J. J. Hoffman, the chairman of the committee, informed me that they had already decided to have a strike without regard to the evidence. I then informed them if that was the case, a further conference was useless, and they could strike if they wished.

"It appears that the two discharged men have more influence with the employees than the committee. We have had applications from a number of men to go to work, and with police protection, we can operate both lines to-day. The sergeant of the police who was sent to the end of the cable line to prevent intimidation, acted in sympathy with the men, and permitted the strikers to gather around the men and prevent them from taking out their cars; for this cause alone the people were compelled to walk to their homes. For the protection of our property we stopped all cable cars at 8 o'clock last evening. If afforded proper police protection we will operate regularly to-day; if not we will cease to run until those of our employees who have proven faithful to the company and the new men we are now employing, are thoroughly protected from interference by discharged employees, and all men who fail to return to work this morning will be regarded as such.

"Yours very truly, G. B. KERPER."

Mr. Kerper said to the committee: "You have inaugurated this strike, and you can keep at it as long as you wish. I don't propose to ever employ those two men again. They have done me and the road and the public a great injustice, and I will not give them employment at any price. You men who wish to return to work now can do so. You can go and run out the cars and return to your work if you wish. But you must go at once. If you refuse to work until these men are reinstated then none of you will ever be employed again. If everything is not running smooth by 8 o'clock to-night, I shall shut down and quit until I can reorganize my forces."

At a meeting of the strikers committee, at the Highland house, Messrs. Atchley and Miller adjured the men not to return to work until their comrades had been reinstated, shortly after which they adjourned to meet again at 8 o'clock at their hall.

The adjourned meeting was called to order by Daniel Wheaton, Master Workman of the Midnight Assembly, K. of L., who addressed the men in a vituperative speech, substantially as follows, at the same time warning them not to interfere with any cars bearing the words U. S. MAIL.

"I congratulate you all on the fine work you have accomplished to-day. You have the sympathy and backing of every friend of labor. I am speaking to you from an official standpoint, and can guarantee you the support of the Knights of Labor of this city. You are in the right, and, now that you have commenced hostilities, must stick together and fight it out. I want to advise everyone here to keep from drinking and not lose your heads.

"You must not do any violence. Be cautious, and do nothing to cause any arrests. Don't intimidate any new men that Kerper may employ. You have the right to persuade them in a respectable manner to leave his employ, but you must not use force or create any disturbance or do any violence. The people are with you, and good behavior will go a great way toward creating sympathy for you. I want you, however, to stick together, and not return to work unless Fallon and Wilson are reinstated. You are not only striking to have these two men put back in their places, but are striking to maintain the rights of laboring men.

"You have been treated like dogs by this man Kerper. He says he believes his superintendent's story before he does yours. You ought to demand Alley's immediate discharge as one of the main conditions before taking out your cars. You have a dead hold on Kerper. He can't get experienced men to run his cable, and every new, inexperienced man he may put to work lays his passengers liable to injury. *He ought never to be allowed to run his cables through Deer Creek when manned by 'scabs.'* One more thing I wish to emphatically say to you. If John Harris, Superintendent of the Consolidated road attempts to send a man over to Kerper to handle his cars, the Knights of Labor will order every car run in on the Consolidated lines. I speak authoritatively regarding this. It is the duty of the hostlers of the Park avenue line to go to the stables and see that the horses are fed and properly cared for. I would advise that, if Kerper attempts to run any cars to-morrow, the Knights of Labor will see to it that the cars are stopped.

"You are striking for your future benefit. This strike is but the first act in a great drama to be enacted. We are bound to bring Kerper to time."

James Fallon, one of the discharged, gave his version of his trouble with Stubb, which led to his discharge, and after about an hour's session the meeting adjourned.

On Saturday morning Kerper ran a car down over the cable-line, which returned to Gilbert avenue loaded with policemen. This was about 5 o'clock in the morning. The police were divided into squads for the protection of the company's property, and one officer was placed on each of its cars. At 7, Kerper put twenty-four new men to work, who were instructed in their duties by employees who had refused to join the strikers. During the day the company operated twenty cars—fourteen on the cable line (seven trains of two cars apiece), and six on the Eden Park division (horse). The new employees were earnestly importuned to leave their positions and join the union, but, to their credit be it said, they stood to their posts of duty. All cars on both divisions were run in at 8 p.m., and a large number of extra police stationed along the line, to check any interference with the cable.

Mr. Kerper issued the following bulletin to the public in the Sunday papers:

"CINCINNATI, September 18, 1887.

"The thirty thousand people on Walnut Hills are indebted to Colonel Philip Deitsch, Chief of Police, for the prompt measures he took yesterday in placing a policeman on each car of the cable and Eden Park street car lines. By

this action the people were carried as in the past to and from their homes without the inconvenience of Saturday afternoon and night. Cars were turned in early in the evening to give the employees a rest and enable the new men to take a recess from their duties. We bespeak for them of our patrons patience and support, knowing they will deserve the same, as they come to us with a determination to do their duty and be faithful in the performance of same. We pledge them good treatment on our part and steady employment.

"With our old employees we have no differences; they left our employ voluntarily, and we wish them success in their new fields of labor. Their places are being promptly filled by men willing and able to learn, and they will soon be taught to fill their respective positions with credit to themselves and our company. In the faithful men who have remained at their posts our patrons will find those who were ever thoughtful, respectful and obliging in the performance of their duty, and to the hundreds of our patrons who yesterday sent their good wishes for our success in maintaining discipline and good order on our lines, we return our sincere thanks, and can assure them that all our present employees and the management will strive to give them such service as will keep for us their continued good will and support. Yours very truly,

G. B. KERPER."

The strikers held a meeting at their hall, where Wheaton continued his abuse of his former chief. Among other things he said: "We are fighting for our principles, and if this man Kerper does not settle with you to-day and reinstate not only Fallon and Wilson, but every man who was in his employ when this strike was started, we will call for aid from our sister assemblies and inaugurate such a strike as will shake the very ground upon which this city is built. We won't put up with any more foolishness. We must get down now to business, and I hope every man here will stick to one another. If Kerper does not give in by midnight, we will hold a meeting of Midnight Assembly at 1 o'clock in the morning, and will hold an all-day meeting to-morrow. All those gripmen, conductors and drivers who have not joined our union, we will be glad to welcome at these meetings. To-morrow morning we will serve Kerper a notice to put all the old men back at work by 2 o'clock to-morrow afternoon, and if he fails to come to his senses we will have to knock it into him and a few others. That man Alley and John Harris, of the Consolidated road, must be discharged, or we will order a strike to-morrow afternoon against every line under the control of the Consolidated company, as well as on the Covington and Newport lines. We can and will show these monopolists who govern the affairs of this city, whether it is the bosses or the laboring men, and we will demonstrate to their complete satisfaction that an organization like the Knights of Labor is a bad thing to fool with. I want to advise all of you not to make any overtures to Kerper. It is his place to come to us. We will make the 'Little King,' as they call him, bow to us before we get through."

And he left nothing undone to start a strike on the lines of the Consolidated roads, on account of a supposed grievance against the genial Mr. John Harris, its superintendent.

Without a minute's delay, Mr. Kerper took prompt and decisive steps for the protection of the property entrusted to his care. One of the first things he did was to get each of his non-striking employes to file affidavits stating that they were loyal to the company, but were in constant danger of their lives at the hands of the strikers, and were intimidated by them. In every case the full name of the intimidator being given.

Armed with these documents, Mr. Kerper had no difficulty in obtaining the fullest possible protection for his men, and was in a position to assure his new hands that they need fear no physical injury at the hands of the strikers.

He then obtained from Judge Peck of the Superior Court, a temporary injunction restraining Jones, Fallon and 47 others from interfering with, or obstructing or annoying the employees of the company in their work, and from coercing them to quit work, and from preventing those who desired to enter the service of the company from so doing. The injunction was obtained on the grounds of conspiracy,

the company alleging that unless the conspirators were restrained from said interference, etc., it would be compelled to discontinue the operation of its lines, upon which from 15,000 to 20,000 people living in the suburbs were dependent for their daily transportation.

Service of the injunction was made upon the following—the names of whom we record for the benefit of other operating companies to whom application may be made for work.

"STRIKING EMPLOYEES."

*Horse Car Conductors.*—J. R. Burch, J. W. McNulty, Chas. Nold, Samuel Swank, Herman Zix, John Hogan, John Hines, Pat Gilligan, Martin Noonan, Tom Brannan, John Finnegan, Charles Zix, John Bland, Timothy Whalan, Chas. Gies. *Drivers.*—Edward Bryan, Geo. Calvert, Joseph Meeker, Chas. Roberts, John Chaney, John McCormack, Wm. Rowe, James Bradley, Cornelius Bradley, Albert Snyder, Edward Tierney, Chas. B. Smith, Wm. Knapp, John Qualey, Jacop Frigger.

*Cable Conductors.*—Charles McCarthy, Henry Miller, Walter Means, R. D. Atcheley, Edward Hines, Tom Ernschaw, Theo. Smith, Charles Stroup, Chas. H. Rogers, Harry Scudder, E. Evans, W. H. White, Bart. McCarthy, H. Hunt, Star O. Burch, C. Burnett, R. W. Degman, John Taylor, Wm. F. Mueller, Henry Alfather, F. M. Atcheley, John O. Reilly, Joseph Kroum, Richard Ferree, John J. Daley, J. Argadine, O. Marshall, George Ensige, Alf. Burnett, Geo. Whitehouse, Posey Curlis, Pat Madden, Clayton Webb. *Gripmen.*—J. H. Puthoff, S. Kirkpatrick, Clinton Strubbs, H. Lindsay, J. G. Scofield, F. M. Bronson, I. Lentz, A. Hollinger, John Kramer, Jerry Conoley, M. Hickey, Geo. Hoffman, Richard Byerly, Thos. Kyle, Frank Hughes, Thos. Bosley, Anthony Dean, James Fallon, John Wilson, Mike Powers, Henry Bitters, James Burke, Zef. Posey, John Murray, Henry Hugelow.

Mr. Kerper being apprised of the fact that a committee composed of Messrs. Hickey, Dailey, Wheaton, Ryan and Hugh Cavanaugh—of the K. of L.—had been appointed to confer with him as to a settlement of the so-called "strike" prepared the following letter:

"Gentlemen:—You come to me as a committee of employees and workmen to submit a communication or make a demand. I can not recognize you in such a capacity, and have no curiosity to know your desires. As old employees, I am pleased to see you in good health and looking so cheerful after your three days vacation. It has apparently done you so much good that I would advise you to continue it indefinitely. If I were you I would not, under any circumstances, return to the employment of a company that has, to the knowledge of Brother Wheaton, treated you as dogs. In my opinion you have acted wisely, and I endorse your action and commend you to those who are better able to appreciate your merits than your humble servant. You have my best wishes and sincerely speaking your families have my heartfelt sympathy. A sympathy growing out of the fact that their husbands, though blessed with hands, seem to have lost their heads. Husbands and brothers who make their families suffer and bind themselves to protect their fellow men right or wrong without regard to the duty you owe to the women and children at home, without any consideration for your employers, who have treated you well, paid you promptly and gave you steady employment rain or shine, without any feeling for the thousands who have ridden with you daily on your cars and contributed the means with which all of us have been able to earn our living. We have all suffered by your action. But the patrons and the company can well afford to suffer, as this movement on your part brings about a radical change for the general good. They will find in your places men of intelligence who came to us determined to do their duty. They will, in a few days, be taught to fulfill that duty just as you were taught. I have a duty to perform and I shall do it without fear or favor. The old men who have been faithful to the company and the new men I have employed have my word that they will be protected and taken care of. That good pledge I have made to them. I propose to stand or fall by my men.

"Respectfully yours, GEORGE B. KERPER."



Hugh Cavanaugh requested Mr. Kerper for a conference, which was arranged for at 2 p. m. Tuesday. Promptly to the minute Mr. Kerper entered the office, but it was nearly an hour later before Cavanaugh, Hickey, Dailey and Wheaton arrived. Cordially greeting the committee, Kerper requested them to proceed at once to business, whereupon Cavanaugh detailed how he tried to dissuade the discontents from striking, etc.

"To what strike do you refer?" asked Mr. Kerper.  
 "To the strike of your employes on Saturday," answered Mr. Cavanaugh.

Mr. Kerper then stated that he knew nothing of any strike having occurred on his line. A number of his men had quit work, it was true, and he had proceeded to, at once, fill the vacancies with new men. He would be pleased to discuss any business matter, if they had any to discuss, but if they came to dictate as to whom he should, or should not, employ or discharge, they might save their valuable time, as he, being responsible to the stockholders of the road, would act solely upon his own judgment and stand by the consequences. Seeing that all efforts to effect a reconciliation between Mr. Kerper and his former employes were fruitless, and realizing the dampening effect that the defeat given to the order, by Mr. Kerper, might have upon it in general throughout the country, Mr. Cavanaugh attempted to show that the men had acted on their own responsibilities, and without any authority, or official knowledge of the Knights of Labor. This, however, had but little weight with Mr. Kerper, who remembered the utterances of Dan Wheaton, when addressing the strikers at the Highland House: "We will demonstrate that the Knights of Labor is a bad thing to fool with;" and again, "the Knights of Labor will see that the cars are stopped."

In order to put a recurrence of this trouble almost beyond the range of probability, Mr. Kerper had each of his men sign the following agreement:

THIS AGREEMENT, made this \_\_\_\_\_ day of \_\_\_\_\_ 1887 between the Mt. Adams and Eden Park Inclined Railway, of the first part, and \_\_\_\_\_ party of the second part.

*Witnesseth*, That the party of the first part has this day employed the party of the second part as \_\_\_\_\_ during the pleasure of said first party, and agrees to pay to the said second party, in consideration of the covenants hereinafter made by him, the sum of \_\_\_\_\_ per day of twelve hours, when at work on day cars of The Mt. Adams and Eden Park Inclined Railway, and further agrees to pay the party of the second part six per cent. per annum interest on such deposits he may have with said Company.

The party of the second part, for and in consideration of the foregoing covenant, made by the party of the first part, agrees to deposit the sum of \_\_\_\_\_ dollars with the party of the first part as a guarantee for his faithful discharge of his duties, and the correctness of his accounts and registering of fares, and as a further guarantee that he will not leave the service of the Company without giving a written ten days notice at the office of the company, and he certifies that he is now and he will be, so long as he is in the employ of the said Company free to make such guarantee; failing to do so, or failing to make proper returns of his accounts, the said party of the second part agrees to forfeit the said sum of \_\_\_\_\_ dollars as liquidated damages to the Company.

*In Witness Whereof*, The said \_\_\_\_\_ hath hereunto subscribed his name, and the Mt. Adams and Eden Park Inclined Railway has caused these presents to be subscribed by its President this day and date above written.

\_\_\_\_\_  
*Pres't.*  
 \_\_\_\_\_  
*Witness.*

The above was read, signed and delivered in the presence of

\_\_\_\_\_  
 \_\_\_\_\_  
*Witness.*

Trouble is brewing among the men employed by the Cincinnati Street Ry. Co., and the decided action taken by President Kerper may well be emulated by others equally situated, if the Knights of Labor repeat their bombastic and ruinous conduct.

It is a significant fact that a majority of the agitators were *single* men, the married ones being for the most part intimidated into joining the crowd. In picking out his new men, Kerper has selected *married* men as far as possible, it being his belief that "single men think only of themselves—married men think of their wives and babies."

### A Threatened Strike Settled.

Honor is due to those who have averted a big strike in Chicago, for not only was the threatened strike turned off, for the time being, but it has been settled amicably. About the middle of September two Lake View conductors were discharged by Superintendent Threedy of the North Chicago Street R. R. Co., and the associated conductors and drivers of that well-regulated system sent a deputation to wait upon President Yerkes. Good reasons were given for the discharge of the men, and there was an end 'n't.

About the same time the spirit of dissatisfaction took possession of the West Side Conductors' and Drivers' Association. They had been discussing their grievances for a month or more, and during the first week of September, a committee, with Luke Coyne as chairman, waited upon Mr. De Witt C. Cregier, superintendent of the Chicago West Division Railway Co. On September 12, we made inquiries of Mr. Cregier, and he stated that "A committee of five, one from each division of the road, called upon the officers of the company last week. They wanted a number of changes made in the method of conducting affairs, little details that come under my department. We had a quiet talk upon this matter, and succeeded in arranging everything satisfactorily to all concerned. They then requested that their pay be raised from 20 to 22 cents an hour. This is a matter with which no one but the Board of Directors can deal. No threats were made and the committee expressed themselves as perfectly willing to await the decision of the board. Two cents an hour for over 1,000 men is a great deal of money in the course of a year. The men also asked that ten hours be a minimum day's work."

Subsequently we called at the treasurer's office; and in answer to the question, "What do the men want?" A young man (lacking the wisdom of his superiors, gained from the insight of experience) declared that "They want the earth," and then seemed to feel that he had spoken wisely. "Look here," said he, unrolling a paper covered with long columns of figures in tabulated form, "two cents an hour at twelve hours a day for 1,200 men is \$288 a day. Multiply this by 365 days and you have the sum of \$95,120. It is this that these men blandly and quietly ask the West Side company to donate them."

Fortunately this short-sighted clerk has not much to do in guiding the actions of the company.

The proposed transfer of the West Side system to Mr. Yerkes' syndicate had something—we might say, very much—to do with the demand for an increase to 22 cents an hour. It was evident the earnings of the company were immense, and the men resolved to make their hay while the sun shone on the fortunes of their employers. It was not the hot-headed young fellows who were foremost in the agitation, it was declared, but it was the older men that took the lead, and at first they advocated a demand for 25 cents an hour, which figure was voted down by a very small minority. Ultimately the demand for 22 cents was unanimous. The demand was made in a respectful but determined manner. The men like Superintendent Cregier very much, for "he is just and fair" said a veteran conductor. "He never bounces a man without cause, and when there is cause the offender must go. Years ago, political influence could keep a careless, stupid, drunken conductor or driver in his place, but there is nothing of that kind now."

The president of the company wrote as follows, Sep. 16th: "Messrs. Forehan, Farrell, Burns, and Others of the Committee—GENTLEMEN: I was unable to bring your matter before the board at its meeting yesterday, but will do so at our next regular meeting, and will arrange for your coming before the board and stating your wishes.

J. R. JONES."

There was a total absence of bitterness between the officials and the employees, and no dispute was ever conducted with more dignity and common sense. And the refusal of President Jones to be interviewed by newspaper reporters no doubt helped the contending parties to keep their balance. The Board of Directors discussed the matter September 21, and resolved to pay 21 cents, if the men would agree to that proposal. The men's representatives, Luke Coyne, John Goodwin, Richard Burns, etc., subsequently held a conference with President Jones, who told them the company had decided they could not grant the request for 2 cents an hour advance, "The directors have decided that a raise of 2 cents is more than we can afford, but we are willing to compromise on 1 cent, and will pay you 21 cents an hour, if that is satisfactory to you," said he. The men's deputation replied, "That can only be decided by the men themselves." "Very well," said Mr. Jones, "I will stay at my office and await your reply."

Then the committee filed out of the office and went at once to Seamen's hall, at 99 West Randolph street, where the men were to receive the report. The committee entered the hall with great pomp, under escort of the emergency committee of thirty-four. Mr. Coyne took the chair, called his following to order, and these forty gentlemen constituting the representative assembly of the 1,600 west side drivers and conductors proceeded to hold a meeting, which lasted from 5 to 7 o'clock. Mr. Coyne told them that Mr. Jones had promised them that the company would compromise on 21 cents, and it devolved upon the assemblage in session to ratify or reject the proposition. After long and heated debate and by a vote of scant majority the former was determined upon, providing the men be given at least ten hours' work a day and every conductor and driver starting out with a car be paid for all the schedule trips whether all the runs be made or not.

President Jones was duly informed of the men's decision, and ultimately he wrote out the following:

"Mr. Luke Coyne, President—DEAR SIR: It is herewith agreed that hereafter no run shall call for less than ten hours' work; that if cars are run in the men will be paid for the time specified on time-tables, and that the pay of conductors and drivers shall be 21 cents per hour, commencing Oct. 1.

J. RUSSELL JONES,

"President West Division Street Railway Company."

It only remained for the general meeting of the members of the West Side Conductors and Drivers' Association to ratify the action of the committee. At 9 o'clock crowds of uniformed street-car conductors and drivers began to assemble in front of Seaman's hall. At 11:30 President Coyne called the meeting to order. Mr. Jones's communication was read and the committee submitted a report on its action. This was followed by a general discussion, which lasted until 1:30 o'clock. Finally a motion to adopt the report of the committee as well as Mr. Jones' proposition was carried, and the meeting adjourned.

Mayor Roche is given much of the credit for the amicable settlement of the trouble. He acted as moderator between President Jones and the men's representatives, at a critical stage of the proceedings. President Yerkes (of the North Side) was closeted with Mr. Jones for over an hour before the men received the offered compromise; and his wise counsel had also much to do, no doubt, with the bringing about of the happy result—the settlement of the threatened strike.

The matter has been settled so well, probably, that no talk of a strike can reasonably be expected among the street railway men of Chicago for a long time to come. There is such a happy feeling between President C. B. Holmes and his army of gripmen, conductors and drivers of the Chicago City Railway Co. (the South Side) that a strike appears impossible there. President Yerkes has also a firm hold on the affections of the men in the employ of the North Chicago Street R. R. Co., and the way the recent complaints there were treated betokens a continuation of the good feeling prevalent between the officials and the men. And now that the West Side discord has been adjusted by mutual agreement—the only way to secure permanent peace—the

men will be content as long as the present company and its officials rule the rails of the West Division; and if the projected transfer becomes *un fait accompli*, President Yerkes and his confreres will receive into their service an army of 1,500 or 1,600 additional experienced men well contented with their lot. And the great and growing City of Chicago is to be congratulated, as far as the prospect of its street railway service is concerned, at all events.

## New York Street Railway Association.

FIFTH ANNUAL MEETING, HELD IN BROOKLYN.

The Street Railway Association of the State of New York held its fifth annual meeting at the Hotel St. George, Brooklyn, September 20th. In attendance were the Hon. G. Milton Scribner (president), Messrs. Wm. J. Richardson (secretary and treasurer), Hy. M. Watson, Chas. Cleminshaw, William Richardson, George S. Hart, John W. McNamara, Daniel F. Lewis, Henry Thompson, John N. Partridge, George Starr, Chas. E. Harris, etc.

PRESIDENT SCRIBNER'S ADDRESS.

*Gentlemen of the Association:* It gives me pleasure as President of the Street Railway Association of the State of New York to welcome you as delegates to this meeting. I shall not detain you with an extended address on this occasion, believing that all subjects claiming our attention can and will be more thoroughly and beneficially discussed during the progress of the session. By such a method of procedure each topic of interest will have light thrown upon it by those members whose personal observation and experience have best qualified them to deal with the subject in the most intelligent and practical manner.

The street railroad interest has grown to large proportions in this state, and its importance as a distinct industry is not likely to be over estimated. Since the formation of this association, a spirit of laudable emulation has arisen, prompting a better service and a desire to adopt better methods in management than existed at any time before. This spirit is in every way praiseworthy, and should be fostered by every means in our power. Every improvement in construction and propulsion which has finally passed the condition of experiment, and which promises a better and more economical service, should be adopted by the companies without hesitation. Of course it cannot be denied by any impartial observer that the several municipal corporations of the state within whose jurisdiction nearly all roads are located, are as a rule not only helpful to the companies, but positively obstructive in taking these advanced steps. Every new motor has had to fight for a mere chance of trial, and in the city of New York a severe struggle awaits any company which seriously sets about inaugurating a better service. In this particular there is little doubt, however, that we are upon the threshold of

A CHANGE FROM HORSE POWER

to some other means of propulsion, which in a short time will force its own way, and will revolutionize the whole system in this respect. Every company should encourage all legitimate effort in this direction, and not only welcome but adopt the first improved method which will answer the purposes of economy and efficiency, for these are the first elements in securing to each passenger the best possible return for his fare.

There is another matter which in my judgment is still more vital, and that is the matter of *unequal taxation*. There is no reason or justice in the present law of this state, which taxes the real estate of street railroad corporations on as full an assessed valuation as that of any citizen, and then taxes the personal estate at three or four times its value, by the false standard of measurement which results from taking the aggregate market value of all its stock as the equivalent in value of its personal property, then afterwards taxing the company's gross receipts, then again taxing separately its dividends or net receipts, which in effect taxes the same property three times each year, taxing also its tracks as real estate, taxing each company specifically for support of the Railroad Commission, and lastly taxing in the city of New



York the cars a specific sum of fifty dollars per annum, with the threat that the companies are next to be taxed on what they owe. The whole system is an outrage, and has no good excuse nor one redeeming feature. If street railroads are inimical to the public welfare, if they are nuisances in the streets subverting the proper uses for which streets are established, they should be abolished by the repeal of their charters. But if they are not so, if investors were justified in the first place in building street railroads, and it is honest and proper to maintain and operate them, then the corporations doing so should pay taxes for their real and personal estates assessed at a full and fair valuation, so that their property should bear just burdens as other property bears, and anything beyond this is an oppression and an injustice, and should not be tamely submitted to by the companies for a moment. But my views upon this subject have been so recently and so fully expressed to you that I will not go further now than to say that this whole matter should be, I think, explained to, and urged upon, the attention of every legislature until relief is granted; and in the mean time no company should submit to the injustice unless compelled to do so by the court of last resort.

There is another law which has recently gone into effect which in my judgment is equally impolitic and unjust, but which affects more seriously those who ride upon street railroads than the companies which build and operate them. Indeed, it does not affect at all the street railroads already in existence, but is curiously illustrative of the principles that injustice sometimes immediately, as it generally does in the end, rests most heavily on those who invent it and attempt to apply it to others. I refer now to the

#### METHOD OF SELLING THE FRANCHISES.

for new railroads to the company which will engage to pay into the city treasury the largest proportion of the money it collects from the persons who ride on its cars. This is in effect selecting out from all those who use the street in common that particular class who chose to ride in street cars, and compelling them through the agency of the company to pay something into the city treasury for the privilege of doing so. In other words, this class are forced to pay a sort of fine or tax for using the street for the very purpose for which the street was made and for which all other persons are freely using it. If such franchises were accorded to the company which would carry people most comfortably, safely and expeditiously and for the least sum of money, such a course would result in using the street to the best possible advantage, without injury or injustice to anybody.

The labor organizations which commenced their existence, or at any rate their last dispensation, by persuading men that they were ill-treated in our employments, at a time when ten new men armed with supplicating letters and recommendations were waiting for the place of each one who was discharged or in any way dropped out, have for the past year so extended their field of operations that the railroads are to a degree obscured and lost sight of for the time being behind the more momentous questions and movements with which these philosophers are now wrestling on a wider and more elevated platform. After much thought I have reached the following conclusions in respect to these labor unions. Between the socialists who claim that the government should do everything and control everything, take possession of all corporations and even fixing all profits in trade, on the one hand, and the anarchists who oppose all government whatever, and claim that every man should be allowed to do just as he pleases, on the other, there exist in these labor organizations every shade of like opinion imaginable, but the tendency of each particular organization is toward the one or the other of these extremes, and to one or the other of these extremes every interfering organization must inevitably reach in the end. If these organizations meddle with other people's affairs according to any rule, it must soon come to be by authority, or a uniform custom having the force of authority, and that is law and government, and so would justify further and further extensions of like interferences, until the government, as the socialists claim it ought, would come to regulate all private relations and lastly how much a man may make in his transactions, or be worth. On

the other hand, for any kind of illegal interference to become chronic is to foster another and still another interference, not different in kind but applicable to some new matter, until no rights are sacred in the individual except such as he can maintain by individual force, and this is anarchy. It is hardly necessary to add that either extreme means revolution as soon as it is reached, and war until order is again established. These troubles, however, have, I believe, come to stay and be tried and tested until these problems are worked out and settled once for all. And who shall say that they may not as well be solved now as at any time in the future?

I could not refrain from at least calling your attention to these three great questions, which are constantly pressing upon the attention of us all—the first involving the adoption of a better motor; the second that of securing relief from unjust and unequal taxation; and the labor question, which is always with us. Nor have I attempted in these allusions to find remedies for, or even to solve our perplexities, but simply to state the nature of them, with the merest hint as to the possible way out of some of them.

There are other topics of interest to us and impinging upon our business and affairs, which I should like to touch upon, but I promised at the beginning to be brief and I will detain you no longer than to thank you each and all for the honor conferred in electing me as your president for and during the last year. And lastly let me assure you that the welfare and prosperity of this association will always be a matter of deep interest to me, in whatever capacity I may be associated with it.

The Secretary, Mr. Wm. J. Richardson, read the report of the Executive Committee. It stated that a more amicable feeling existed between employer and employee than in the past, and as evidence of this fact there had been no strikes reported during the past year. The committee recommended making street car lines

#### UNITED STATES MAIL ROUTES.

Mr. Cleminshaw said that his road had completed arrangements of this kind. Secretary Richardson read letters from George B. Kerper, president of the Mount Adams and Eden Park road of Cincinnati, in which Mr. Kerper spoke highly of the mail plan which had been adopted by him.

The report of the Treasurer was read next, and it shows the present membership of the association to be 27.

A paper on "Car Building by Street Railway Companies," having been prepared and forwarded by William White, of the Dry Docks, East Broadway and Battery Railroad Co., was read by the secretary. It recommended large companies to construct their own cars, but advanced no new argument, and this subject has been thrashed out in previous issues of the STREET RAILWAY GAZETTE.

#### THE BEST CHECKS UPON CONDUCTORS' RETURNS.

Mr. Jas. A. Bonnell (of the Atlantic Ave R. R. Co. of Brooklyn) read the following special report upon the "Best System of Checking Conductors' Returns:—"

The time was when the title "conductor" of a horse car was synonymous with that of a petty thief, and a man who held such a position was not given credit for honesty by the general public. His temptation to be dishonest was greatly increased by the fact that a large number, if not a majority, of his associates were dishonest. Since the introduction of the alarm register, a great change has taken place as to the estimation in which the integrity of the position of a conductor on a street railway is held by the public as well as the company. Now the conductor has it in his power to show to every passenger who rides upon his car that he is an honest man, by always recording a fare promptly upon its collection. It was not an uncommon occurrence for a conductor to be jokingly, and sometimes seriously, charged with "knocking down." Now a conductor who is similarly charged, is justified in knocking down with his fists any person who so addresses him, thus questioning his integrity.

There is no occupation upon which a man may enter the tests more thoroughly of his inherent honesty; for it is simply impossible for the officers of a company to know exactly how many passengers ride upon a car and how many fares

the conductor collects. This could only be known by the employment of a "counter" to ride on every half trip the conductor makes. Of course, this would be impracticable. However, a man who is honest is honest all the way through; a man who is dishonest is likewise dishonest to the core. He may not steal in on some trips; he will steal on others. He will sooner or later be discovered and ultimately discharged; and so far as his discharge may affect his obtaining other employment, blast his reputation. He will know that he has brought it upon himself, and that he alone is to blame. No man is obliged to work for the wages that are paid him. If a man is not satisfied therewith, it is his duty to honorably resign from the employment of the company, and to give his position as a conductor to a man who is willing to work for the wages paid.

There have been many kinds of alarm registers invented for the checking of the collection of fares. They are essentially of two different characters, one class being known as "open," the other as "secret." The principle of one is that the conductor and the public shall know the number of fares collected, while the theory of the other is that neither the conductor nor the public shall know the number of fares collected; but that both shall be kept in ignorance thereof, so far as the same is disclosed by the register. Both systems have their warm advocates, and it is a question which is the better. The advantage that is claimed for the "stationary" register, namely, that the record made by the conductor may be seen by himself and the public, is considered for that very reason by those who advocate the "secret" register a disadvantage, and *vice versa*. The advantage of a portable register are, that being always carried by the conductor it is absolutely under his control and free from interference by the passengers or others also, fares can be more rapidly collected with it than with a stationary register, because of its immediate presence with the conductor. This, of course, applies to those portable registers that are suspended from the shoulders of the conductor, leaving both hands free for the collection of fares. With a portable register, it is possible to have two sets of mechanism and alarms, covering "half" fares as well as adults' fares, in this way keeping the record for work done by the conductor absolutely correct. An evident disadvantage in a portable register is that it affords greater opportunity for the use of a "dummy" or false alarm bell in connection therewith. As an offset to this evident disadvantage, however, will be the detectives' returns, which ought very soon to disclose the improper use of such a false bell.

One essential rule, we think, should be applied to all alarm registers, regardless of their fundamental principle being either open or secret, and that is, a conductor should not be required to register a fare until he collects it. A stringent rule, that can be rigidly enforced, which will require a conductor to collect his fares promptly upon a passenger getting upon the car, will obviate the necessity of the conductor being obliged to register a passenger as soon as he steps upon the car and before the conductor collects the fare. It seems to your committee that this manner of registration is but fair to the conductor, and in so important a matter doing only as we would wish to be done by, were we in his place and he in ours.

No alarm register, however perfect, or upon what principle constructed, will work itself. If a man is naturally dishonest, he will find some way of circumventing the register; either by not ringing at all, and thus barefacedly declaring that he is dishonest, or else by the use of a false bell, or by some other ingenious device, attempt to deceive the passengers and mulct the company. It is, therefore, necessary for every company to employ counters or detectives, and the system of management of these detectives will be such as may be best adapted to the demands of each separate road.

A disadvantage in the stationary register is, that it is not always exclusively under the control of the conductor. It is sometimes possible for a passenger to pull the register strap in mistake for the drivers' bell strap for the stopping of the car. In case of a fire, especially if it is prolonged, the record that may have been made for that day is very largely destroyed if the stationary register is used, by reason

of the fact that the conductor, being obliged to leave the car he first had, and take his passengers across the impending hose to another car, upon the other side, may get his accounts thereby considerably mixed, while for the counters who may be riding on the cars, the records of the registers would be made practically of little use, at least so far as showing totals is concerned. The merits and demerits of a stationary register, forming a part of the car, are:

Merit—If open face, a "ready reckoner" of the conductor's work.

Demerit—Because a ready reckoner, the conductor not being obliged to count his fares, in case he should have forgotten to register a fare (inasmuch as he has not counted his money at the beginning and end of the trip), the company would be the loser of the fares collected and not registered.

Merit—Being stationary in the car, whether "open" or "secret," a larger instrument, and, therefore, a much larger bell, may be used than it is possible to have in a portable register, and thus less danger of its being imitated by false or "dummy" bells.

Demerit—Being stationary and away from the conductor, it is not so easily manipulated as a portable register carried on the conductor's person, especially on "rush" trips.

An open-face register, while it has the advantage of assisting an honest detective, yet as all men are not honest, it may be made use of by a detective to enable him to make his work easy by his failure to count every passenger whose fare is collected, but simply to rely upon the record made by the conductor upon the face of the register for the counter's returns. It will be seen, therefore, that what may be or should be an advantage, is sometimes turned to the company's disadvantage. The stationary register being so large, it is not considered practicable to have two sets of registers, one for adult and the other for half fares, and this, as is manifest, introduces an element of discord into the conductor's record, either, on the one hand, by his ringing once for two half fares, or on the other by ringing once for each half fare.

The "secret" register has the advantage over the "open," in that the conductor is required to count his money at the end of every half-trip, and after deducting his own to turn the fares in to the company, thereby obliging him to know whether he has stolen from the company or not. In the case of the open register he will not count his money to ascertain that fact.

To summarize the relative advantages of the stationary and portable registers, would say, first, the portable has the advantage over the stationary register in the more rapid collection of fares; second, it is of greater advantage over the stationary register in being absolutely under the control of the conductor and free from interference on the part of outsiders; third, it is of greater advantage over the stationary register in that being portable, it accompanies the conductor in case of fire or other disturbance on the road when the changing of cars is necessary; fourth, it is of greater advantage over the stationary register, in that it is manipulated by the conductor and register inspector only. The stationary register must be adjusted at the end of every half-trip by the starter, and the possibility of collusion is enhanced when the register is open-faced. The advantage of the stationary register over the portable register is that, being much larger, and the alarm louder in sound, the conductor has not the same opportunity for using a false register.

An additional check upon conductors' returns, and which your committee considers to be a valuable one, is a check against receivers in the office. A slip should be prepared for a summary of each conductor's work for the day, and inclosed in an envelope addressed either to the president or one of the officials of the company, and it should then be examined to see that the summary thus represented by the conductor is identical with the work upon the receiver's books. This precludes the possibility of a receiver altering the pencil figures of the conductor on his day slip and thus defrauding the company. No honest man, whether receiver or conductor, will object to the placing of as many legitimate and proper checks upon the work done by him as are



necessary, but would rather invite the placing of such checks upon his work, and such a man would heartily wish for such a register as would preclude the possibility of pilfering from the company, were such a thing in its very nature possible.

Again we say, in closing, see to it that your detective system is as nearly perfect as is possible to get it, and do not rely too much upon the alarm register that your company may use.

#### STABLE DISINFECTANTS.

The subject of disinfecting stables was thoroughly and ably discussed. William Richardson believed in lime and copperas. Mr. Scribner stated that a deodorizing preparation had been used by the Belt Line while the burned horses were being removed. Mr. Cassaber spoke in favor of copperas, and explained the difference between a disinfectant and a deodorizer. He also said that assafetida was valuable for the benzoic acid it contained. Mr. Cleminshaw had tried scrubbing and burning sulphur.

[Mr. McNamara, at this time, made some sensible, as well as facetious, remarks bearing upon the fact that the Brooklyn companies had prepared a very good dinner for the entertainment of their guests, and that it was already served. Thereupon all adjourned to the dining hall.]

After dinner Mr. Joshua Crandall, superintendent of the Broadway R.R., Brooklyn, read a special paper on "Disinfecting stables and hospitals for horses." But the pith of the paper was a statement on the construction of stables, stress being laid on the importance of good ventilation.

The committee on nomination of new officers reported the following, who were unanimously elected: For *President*, John W. McNamara, of the Albany Railway; *First Vice-President*, C. C. Woodworth, Secretary Rochester City & Brighton R.R. Co.; *Second Vice-President*, John N. Partridge, President Brooklyn City & Newton R.R. Co.; *Secretary*, William J. Richardson, Secretary The Atlantic Avenue R.R. Co., of Brooklyn; *Executive Committee*, G. Hilton Scribner, President Central Park, North & East River R.R. Co., Daniel F. Lewis, President Brooklyn City R.R. Co., and Lewis Lyon, President of the Third Avenue R.R. Co., of New York.

It was determined so hold the next meeting in the city of New York.

#### Personals.

MESSRS. GEO. B. KERPER and H. H. LITTELL and wife will be the guests of Dr. Warner, Philadelphia, during the forthcoming Street Railway Convention.

MR. and MRS. H. A. EVERETT, of Cleveland, O., will attend the Convention. Likewise the "Dr."

PRESIDENT CALVIN A. RICHARDS, of the Boston Metropolitan, will be at his post, as usual, and will have his paper ready at the Convention.

MR. F. J. SPRAGUE, vice-president and general manager, together with Mr. H. McL. Harding, general agent, of The Sprague Electric Railway and Motor Co., were in Chicago the third week in September, on their way west. They visited the Chicago Electric Club September 19, and received a hearty welcome. In response to urgent request both addressed the club.

MR. F. T. LERNED, general agent of Mr. Frank H. Andrews, New York, was in St. Joseph, Mo., the latter part of September, when he closed a contract for the construction of the Olive Street Cable Railway. While in Chicago, on his return journey, he called at the office of THE STREET RAILWAY GAZETTE, as every gentleman connected with street railway work should do. We were glad to see Mr. Lerner once more, and to find him in such good health and spirit. We regret, however, that he fears he may not be able (on account of pressure of business) to attend the forthcoming Street Railway Convention at Philadelphia.

MR. TOM L. JOHNSON, Cleveland, O., is so extremely busy that he has asked the officers and executive committee to excuse him from doing his part to prepare the paper on Cable Motive Power for the Convention, which subject has been placed in the hands of the special committee of which Mr. Johnson is chairman.

## POINTERS.

### ALABAMA.

*Birmingham.* The Milner Springs & Birmingham Street R.R. Co. have not yet decided what kind of motor they will adopt on their proposed line of four miles of track, a mile and an eighth of which is already constructed.

### CALIFORNIA.

*East Oakland.* Experiments continue to be made upon the Casebolt overhanging system of cable roads and Keith's telephage electric system. The former, it is stated, has been a success. While the electric motors operate, yet the system of regulating the speed is not as satisfactorily arranged as yet, and the inventors are hard at work remedying weak points.

R. Chabot, Henry Martin and others have applied for a street railway franchise.

*Livermore.* Town trustees have granted a charter for a street railway to J. W. Seligman of New York, E. R. Lilienthal of San Francisco, George W. Comegys and G. C. Stanley of Livermore. The motive power is to be steam or otherwise, and the charter calls for ten principal streets, all leading to main county highways and being keys to entrance to the town. Seligman is a prominent New York banker, and as a Santa Fe official has invested in town property.

*Napa City.* The city trustees have granted a franchise to W. T. Henning, Dennis Spencer and others, for a street railway, to start from the corner of Main and First streets, extending to the city limits at the head of First street, with a branch line at Randolph, running to the intersection of Calistoga and Lincoln avenues. The cars are to be run by horses, electricity or cable, and are to be completed by September 1, 1889.

Work on the electric street railroad, from the head of Main street to the asylum, is expected to begin soon.

*Oakland.* The Telephage Electric Railway Co. has completed the construction of a roadbed and plant on New Broadway for experimental purposes. Electricity is generated in a temporary building near the corner of New Broadway and Piedmont avenue, by means of an ordinary engine and boiler. From a thirty-horse power dynamo the electricity is conveyed by wires to conductors in the conduit midway between the rails of the track. On each car is an eight-horse-power dynamo, which, revolving at the rate of 1,600 revolutions per minute, transmits sufficient power to run the car at the rate of ten miles per hour. One mile of track has been laid, and the conduit between the tracks is similar in appearance to that of cable roads. The motor connects by means of a shuttle with an electrically charged rod running from the large dynamo in the engine-house, and thus force is supplied. It is proposed to extend the line southward to Fourteenth street.

*Sacramento.* The city trustees have granted franchises for two additional street railways, one to Alsip & Lewis and the other to Frank N. Myers. "The boom continues here, and the daily real estate transactions amount to thousands of dollars."

A cable railway company has also been incorporated.

*San Francisco.* The latest surprise here is the conviction of ex-state Senator J. Creighton in the superior court, on the charge of jury-bribing in connection with the suit for damages commenced against the Sutter Street Railroad company a few years ago by a widow whose husband had been run over and killed by one of the company's cars. Indictments for attempting to bribe the jury in this case were found recently against Robert W. Morrow, a millionaire and principal stockholder in the Sutter street road; James McCord, a prominent politician and ex-superintendent of the road, and Creighton and F. N. Northey, two local politicians, who, it is claimed, were employed by Morrow and McCord to bribe the jury to render a verdict favorable to the corporation. Creighton is the only one who has been tried, and when he was convicted the court ordered him to appear for sentence. The penalty for Creighton's offense is one to ten years' imprisonment, and there seems to be no doubt he has left the state. Advices from Tucson, Arizona,

Oct. 5, stated that he had passed through that place, and it is supposed here that he was on his way to Mexico.

The Powell-street Cable Railway Company, having nearly completed its road-bed, is now engaged in putting in the sections of track which cross the lines of the Sutter and Geary street companies at right angles. This work involves considerable trouble, as it must be done without interfering with the running of the cars on the roads which are to be crossed. The problem, however, has been satisfactorily solved, and crossings have been made on Polk street, at its intersection with Washington and Jackson streets.

The long-talked-of transfer of the Clay Street Cable Road to the Powell, Jackson and Washington streets cable extension, now being built and nearing completion, is no longer a rumor. A bona fide sale has been consummated. The price is not definitely known; but it is understood to be between \$250,000 and \$275,000.

*San Jose.* "The gem of the golden west," San Jose (pronounced San Ho-say), is being "boomed" with unusual vim. Six columns, *i. e.*, a whole page except one column, of the Chicago *Inter Ocean*, Sept. 28, was occupied with an illustrated article on this "suburb of paradise," which has an "ever-smiling sky overhead, and a multitude of handsome young ladies promenading the streets." San Jose is the county seat and principal city of Santa Clara County, and is said to have at present a population of 25,000 (including suburbs), which is nearly double that given in our directory—taken from the last census. The city is well supplied with street railways; still there's more to follow; and they are going to have an electric railway right away—a franchise therefor having been granted J. B. Randal, et al.

*San Luis Obispo.* The San Luis Obispo Street Railway has been constructed from the depot of the Pacific Coast Railway to the northern end of Higuera street, about one and a half miles. The tracks will be laid through other streets immediately.

*Santa Barbara.* The Santa Barbara Street Ry. Co., has completed its road to the Mission. Further extensions are contemplated.

#### FLORIDA.

*Fort Meade.* The F. M. Street Car Co. intend to add a quarter mile new track (making a total of  $4\frac{5}{8}$  miles) and three switches, within the next few months.

#### ILLINOIS.

*Chicago.* A new ordinance has been prepared by Ald. Clarke, requiring railroads occupying streets to pay an annual revenue to the city of 5 per cent. on the valuation of the street as ascertained from the price of contiguous property. Other members of the council think this is practically leasing the streets, and question the city's right to do so. The corporation counsel has been asked to give his opinion of the matter.

One of the cables that will be used on the new Clark street cable road reached here Oct. 1st, and it is President Yerkes' intention to have it strung as soon as possible. It is the cable that will extend over the section of the road between Illinois and Division streets. The other cables are expected shortly, and if they are sent on according to contract the road will surely be in operation by the middle of November. One of the tunnel tracks has been completed and a car was run through the big bore early Oct. 2d, as an experiment. It was the first street car that has ever been run through a Chicago tunnel, and it went through without an accident of any sort. The experiment was rendered necessary, Mr. Yerkes thought, because the space inside the arches in the center of the tunnel is very limited, and besides the tracks deflect a little to one side. It required the most delicate sort of engineering to make a curve that would cover the deflection exactly, and it was thought best to see that it had been done all right before completing the work.

The West Side deal has not been completed yet, but all that remains to be done is to draw up some of the legal papers necessary to make the transfer complete. Messrs. Widener and Elkins, the Philadelphia capitalists, who, with President Yerkes, are at the head of the deal are here now, we understand, and it is more than likely that be-

fore they leave again the sale will have been consummated. It is understood that President Jones' action in granting the demand of his drivers and conductors for more pay and hours will not have any influence on the result of the negotiations between him and the Philadelphians.

A serious accident occurred on Lincoln av., Sept. 28th, caused by an insecure coupling device which has been adopted by the North Chicago Street RR. Co., on the cars which they have recently had remodeled to suit the cable system. Heavy cast-iron bumpers have been placed at each end of the cars and the whiffle-trees are insecurely fastened by a light coupling pin dropped into the hole in the bumper. The coupling-pin worked out of a car near the corner of Cleveland and Lincoln avenues, and the horses were frightened by the flapping of the whiffle-trees about their legs. They broke loose and ran into the rear end of another car on the Webster avenue line, smashing the platform and seriously injuring Mrs. Louis of No. 546 Cleveland avenue, who was just getting on the car. One of the horses was killed and the other badly hurt. The driver, who kept hold of the lines, was pulled over the dashboard and thrown on his head on the pavement, but escaped serious injury. Another Lincoln avenue team ran away from the same cause but did no damage.

*Chillicothe.* The Chillicothe Street Ry. Co. has been incorporated by Linus S. Hoyt, Wm. Mead, Rollin L. Smith, and John S. Russell; capital stock, \$50,000.

*Cicero.* An ordinance was passed by the Cicero Town Board, October 5, which will enable the Wisconsin Central Railway Co. to compete with the Chicago & North-Western Ry. Co. for the suburban passenger transportation traffic of the West Side of Chicago. The rights granted to the Chicago and Western Dummy Ry. Co., in 1881, are transferred to the Chicago, Harlem and Batavia Ry. Co. (to be sold by them to the Wisconsin Central Co.), who thereby undertake to maintain and operate a suburban passenger railway along the route prescribed in said ordinance of Aug. 20, 1881, and they are granted the right to connect its track or tacks as now laid, or as they may hereafter be laid, while the track or tracks of the Chicago and Great Western Railroad Company over property which it may hereafter own or control at some convenient point, to be agreed upon by said companies, between Fortieth street and Forty-sixth street, in the town of Cicero, and the right for that purpose using no greater curve than 12 degrees to cross all necessary streets, alleys and public places, together with the right to straighten or render practicable all existing curves in said right of way or tracks. It is stipulated that hard coal is to be used; that the road shall be kept in good repair; and that safety gates shall be erected at crossings designated by the Town Board. It is expressly provided that no freight trains shall be run over said road. And residents of Cicero hope soon to be able to reach the business center of Chicago very comfortably.

#### IOWA.

*Centerville.* The People's St. Ry. Co. intend to ballast their tracks, and they propose run freight cars.

#### KANSAS.

*Atchison.* The Atchison *Patriot* says: "Beeson's Fifth street cars have become so wabily of late that the passengers have to hold on to the guards whenever the mules go out of a walk. It will be a relief to his patrons when the cold weather compels him to pull them into the barn"

*Bellville.* The Bellville Street Railway Company, Republic county, has been incorporated. Capital stock, \$20,000. Directors: J. R. Burton, Abilené; B. R. Hogin, Bellville; Geo. W. Findley, D. A. Maulton, J. W. Hamilton, Topeka; G. W. Daty, W. H. Lord, and L. E. Finch, Burlingame.

*Beloit.* No work will be done until next spring on the Beloit City Street Railway, which is to be somewhere between two and four miles long when constructed.

*Clay Centre.* Mr. Campbell managed to have two cars from the La Clede Car Co., St. Louis, in time for the Fair, September 27.

*Dodge City.* The Dodge City & South Dodge Street Railway Company has been incorporated; capital, \$20,000; Directors: Jas. H. Crawford, Charkley M. Beeson, Louis K. McIntyre, D. F. Owens, Walter C. Shinn, all of Dodge City.



"These gentlemen are all hustlers," says our correspondent, "and are heavily interested in the enterprise and will push it through without delay."

**Hutchinson.** The Hutchinson St. Ry. Co. contemplate an extension to South Hutchinson for which a new bridge will have to be built across the river.

**Leavenworth.** A correspondent says "the city council have overcome with a rush all objections to the dummy line which had had considerable trouble heretofore. Mr. Newman Erb, of Memphis, Tenn., is the ostensible head of the concern, but Sam Scott, of Kansas City, is the power behind the throne. The road covers eight miles, and runs from the soldiers' home to the fort, thence to the city, and is one of the most valuable franchises in the state of Kansas.

**Newton.** The Newton and Wichita Rapid Transit company has been chartered to run a line between the two cities, a distance of thirty miles. Capital stock, \$200,000. Directors, A. P. Smith, S. D. Williams, B. C. Parmelee, J. R. Dresden and E. J. Turner.

**Pratt.** At a meeting of the city council, Sep. 20, two street railway companies chartered to do business in Pratt, to-wit: The Pratt Street Railway Co., and the City Street Railway Company of Pratt, appeared before the council asking for franchises to build and operate a street railway in Pratt. Representatives of both companies were present and announced themselves ready to commence operation at once. A vote of the council decided that the franchises be given to the Pratt Street Railway Company, and a committee was appointed to draft an ordinance to that effect reciting terms, conditions, etc.

**Strong City.** A correspondent informed us that street cars run regularly between Strong City and Cottonwood Falls.

**Topeka.** The Rapid Transit company have now fifteen miles of track laid, and are now running eight cars.

**Wellington.** The Citizens' Street Railway Co., have three miles of track in operation (16 lbs. T rail), and have five cars running.

**Wichita.** The Market Street Horse Railroad of Wichita has been incorporated with a capital stock of \$50,000. Directors: H. H. Richards, George W. Walter, L. D. Skinner, George C. Strong and George L. Douglas.

Wichita will have an electric railway in operation in a few days. Mr. T. C. Hughes, engineer of Electric Motor Co., says: Two miles of the overhead conductors are already up. The branch which runs to the Alamo addition is not yet equipped with overhead conductors but shortly will be. On that line they will use a steam motor and two cars which will run the line all through the route. The dynamo used by the electric company, is made by Rush & Co., is 14 horse power and technically known as the Genoesse motor. Experts regard the cars as excellent specimen of beauty and utility combined, the power being concealed beneath the car and invisible almost. The completion of this line will be of great convenience to the public and by those living along the route, it is anxiously looked for. It has been an enormous undertaking costing more than \$9,000 per mile, and aggregating between \$45,000 and \$50,000.

Mr. H. S. Iselin, general manager of the Safety Electric Ry., and Power Company of New York, (Daft system), is here making arrangements for the electric motor line on Central avenue, which it is proposed to have in operation within sixty days. There will be no experimentalizing with this power, as the motor to be used is now operating successfully in Los Angeles, Cal., in Baltimore and in Asbury Park and Orange, N. Y.

#### KENTUCKY.

**Louisville.** The Kentucky Street Railway Co., has a separate existence, President Minary informs us, and they own nine miles of track, and eighty cars, but have the same operated by the Central Pass. R.R. Co., of which Mr. Minary is vice-president; and the moving power is included in the 778 mules of the latter, as reported in our Directory Supplement this month.

#### LOUISIANA.

**New Orleans.** The Algiers and Gretna Railway Co. will probably run two more cars the coming winter, making five

in all. The road is 3.1 miles, single track, with five sidings, the gauge being three feet. They employ 17 horses, and have one dummy not in use. The line runs from Algiers, through Gouldsborough, to Gretna; and the company has right of way to Harvey's Canal, which is a mile further up, and that extension will be built in the future, so President Auvray assures us.

At City Hall, September 27, the specifications of the Canal and Clairborne Railroad franchise, together with the offer of \$55,000 for the renewal of the franchise, were taken up. The ordinance failed to pass, and the vote standing 13 to 8 against, and requiring 16 votes to pass.

#### MASSACHUSETTS.

**Boston.** A hearing of the Suburban Street Railway was held September 26th, before the railway commissioners. Henry D. Hyde and Elmer P. Howe represented the petitioners, who asked for an increase of capital stock for the purposes of equipment and construction. The following was ordered by the commissioners: That said company is hereby authorized to increase its capital stock for the purpose of constructing its railway in the localities heretofore granted by the Board of Aldermen of the city of Boston and selectmen of Brookline, respectively, and for the purpose of equipping the same by the addition thereto of \$100,000, so that the capital stock shall be \$150,000.

Open cars are being taken off and closed ones substituted on the Metropolitan and the Consolidated lines, as well as on the suburban roads, on account of the prematurely cold weather.

The Consolidated and the Metropolitan street railway companies are running a certain number of cars at stated times direct to the exhibition, by the Massachusetts Mechanic Charitable Association, now held in the city, at usual fare of five cents. The South Boston Street Railway Company is running five cars within an hour from South Boston direct to the exhibition buildings, on Huntingdon avenue. Fare, five cents.

**Cambridge.** The Cambridge Railroad Company have received from New York, the new electric car, which is now, at time of writing, receiving its equipments for completion. When completed, a series of experimental trips will be made. The car itself is of the ordinary Stephenson pattern, differing, however, in this, that the floor is a few inches higher than the platform. This arrangement is for the purpose of allowing sufficient space beneath for the motors. There is a Sprague motor over each of the two axles. The interior of the car contains an electric chandelier, four lights in the center, others at the ends, electric signal bell, electric alarm bell, and other contrivances for the comfort and safety of the passengers. The passengers will communicate their wishes by pulling a strap by which an automatic whistle is sounded. The car is marked "West End Street Railway" and "West End Railway Company." The car will make its first regular trip between Harvard and Bowdoin squares within a short time. A further description thereof appears under New York City.

**Newburyport.** The Black Rocks and Salisbury Beach Street railway Co., will extend their road toward Hampton river, which is four miles from their present terminus.

#### MICHIGAN.

**Detroit.** The Metropolitan Electric Railway Co., who contemplate building an electric line (Fisher system) on Belle Isle Park, say "the probability it that work will commence in the spring."

The Detroit City Railway have had suspicions for a considerable time that the receipts from their Congress and Baker street line were not as large as they should be. An investigation led to the belief that the company was being defrauded by a combination of conductors and drivers. On Oct., 1st, the company began paying off and discharging men supposed to be in the combination. Seventy-six were disposed of in this way, much to their surprise. Some of the men got intoxicated and shortly after dark attacked and severely beat one or two of those who had taken their places. One team of horses ran down the street, causing terror among the people. The rioters dispersed just before the police arrived. Superintendent Barry of the lines named has also

been discharged, the company thinking he should have discovered the leakage himself.

*St. Joseph.* The St. Joseph and Benton Harbor street Railway Co., contemplate one mile extension.

#### MISSOURI.

*Independence.* The Independence Ave. "air line dummy" has petitioned the board of aldermen for a franchise.

*Kansas City.* An electric explosion occurred recently on the Kansas City Electric Ry. Co.'s line (Henry system). As one of the cars was passing Fifth and Harrison streets, about mid-day, the electric motor exploded, entirely demolishing the car and injuring a passenger named Robinson. Within an hour, however, the wreck was removed and traffic resumed.

The Kansas City and Olathe Investment & Rapid Transit Co. will require complete equipment for their new road, which will have a track 16.6 miles long when completed. They are investigating the electric systems, and have not yet decided what power to use. They "possibly may enter the city by cable traction."

George Klinger has entered suit in the circuit court by his next friend, Edward Vozi, against the Metropolitan Street Railway Company for \$20,000 damages. The plaintiff alleges that while riding on an Eighteenth street car, on May 20, he was thrown from the front platform and run over, through the running away of the team drawing the car, at the corner of Grand avenue and Eighteenth street. His left foot was mangled to such an extent as to make amputation necessary.

The city council has granted a franchise to the Kansas City & Suburban Belt Railway Company for a double-track railroad on Second street from Harrison street to Broadway. The franchise is to run for thirty years, and the road is to be completed within two years from the date of its acceptance. The grade of Second street will be changed considerably by the building of this road. At Campbell street the grade will be cut down sixty feet. The franchise requires the company to deposit \$10,000 cash with the city comptroller as a guarantee that the road will be built.

The Union Railway Company has been chartered, with a capital stock of \$300,000, to build an extensive cable road on the north side of Kansas City. One of the directors, Mr. H. L. Coombs, says that thirteen miles of cable road is projected. The other directors are: Benjamin F. Coombs (president), M. G. Harmon (secretary), John P. Loomas, Walter Harwood, H. M. Elliott, C. C. Clements, William L. Luck, C. H. Hartman, J. B. Broadwell, H. J. Bruner and A. R. Cecil. This company was incorporated last June, but hitherto they have managed to "keep it dark." In fact, they had not selected their location until recently. Now a franchise has been filed, and they anticipate that the construction of their projected road will cause the rapid building up of the East Bottoms, and the company has in view the erection of mammoth warehouses along the proposed route. Wholesale houses will also be established. The company will use the Terry grip, and it is claimed that the road can be built for one-half the cost of any of the cable roads now in operation in this city.

*St. Joseph.* The Circle Cable Railway is being constructed as rapidly as possible.

The contract for the construction of Olive Street Cable Railway was let Sept. 24, to Mr. F. T. Lerner, general agent to Mr. Frank H. Andrews, New York. The contract provides for the commencement of work within sixty days. A large sum of money has been deposited in one of the banks of the city, and will be forfeited in case the contract is not complied with.

#### NEBRASKA.

*Grand Island.* The Gr. Is. Street Ry. Co. are constructing a mile of new road, and have four new cars under contract.

#### NEW YORK.

*Brooklyn.* An accident occurred on the Brooklyn elevated railway, Sept. 19th. An engine of one train ran into the rear of the other, and the boiler head of the latter was blown out, and the furnace door of the latter was forced off. Steam escaped and enveloped both engines. Engineer

Hollenbach extricated himself after the crash and got out on the plank platform, but fireman Cooper was penned in his cab. His situation was a frightful one. Steam was escaping all around him and burning him terribly. He begged the bystanders to end his misery by shooting him. Engineer Hollenbach, who sprang from his engine to the plank platform, escaped almost unhurt. He had enough presence of mind to save his life, but not enough to put down his lever and stop his engine. The cars were half full of passengers. A number were hurt, but none killed.

*New York.* The Sprague Electric Railway and Motor Company recently exhibited its new electric car, built for the West End Street Railway of Boston, to a small party of invited guests. Among them were S. D. Greene, F. Wilson, C. W. Jenks and H. J. Tucker of the Sprague Co.; John Stevenson, the builder of the car; C. M. Oakley, of the Belt Line; G. B. Prescott, of the Metropolitan Line of Boston; D. L. Jones of the Belt Line of Utica; and others representing roads in the West. The car is a handsome one of the usual size of a horse car, but higher and making a finer appearance. There are two motors of seven and one half horse power each, placed under the floor. The shaft of the armature or the revolving part of the motor ends in a pinion, which meshes into a gear wheel, controlling the wheels of the car. The electricity is supplied by a storage battery of 120 cells placed under the seats. The battery will run the car for about four hours without recharging and the speed may be made to reach fifteen miles an hour, or even more. The whole is controlled by a lever on the front platform.

When everything was ready Mr. Greene took his place in front and pushed the lever to the right. There was a flash of green fire at his feet and the car moved off. The route was through the tunnel to Forty-second street and thence up Madison avenue. After those on board had sufficiently admired the easy motion of the car, they found amusement in the wondering expression of the people along the way.

Twenty-eight and Twenty-ninth Streets RR. Co., has a capital stock of \$500,000. The officers are: President Jonathan H. Crane, Vice-President Edward P. Beach, Secretary Frederick A. Bartlett, Treasurer John H. Davis. This company will build a track of about five miles in length, with 47 lbs steel, side-bearing rails. It is agreed to pay the city 29.2 per cent. of the gross receipts for the first five years and 31.2 per cent. thereafter.

The North and East Rivers Ry. Co. will probably commence operations the first of December. The Electric road propose to rebuild the horse car track in order to allow the Bleeker Street Company to run its cars over the electric railway for the four blocks where the two roads conflict and also to Broadway.

#### A LEGAL DECISION.

Among the decisions handed down by the General Term of the supreme court, September 24, was one regarding the Broadway Surface Road, of which the following is a synopsis:

"In the case of the people upon the action of the Attorney General, against John O'Brien, receiver of the Broadway Surface Railroad Company and others, the General Term affirms the judgment of the trial court without prejudice to the attorney bringing such action as he may be advised, to test the validity of the so-called traffic contracts."

It is held that the act of 1886, which annulled the charter of the Broadway Surface Railroad Company, is constitutional; but its effect was only to kill the company, not to destroy its estate. The property of the company, of which the franchise to operate the railroad in Broadway was part, passed, upon the death of the company, first to the directors, and afterward to the receiver, charged, however, with all the mortgages and contracts which the company lawfully created. The court holds that the franchise to operate the railroad was property, because by the constitution of 1875 it was made the subject of sale by the city and of purchase by the company; and the tenure upon which the Broadway Surface Company held it was not simply for the life of the company, but of such duration as would be adequate to give



full force to the contract of purchase and sale; that, since by the statute it could be mortgaged, the law authorizing contracts and mortgages imparted such tenure as would be adequate to uphold both contracts and mortgages.

The mortgages upon the railroad and franchises to operate it were not affected by the death of the company. With respect to the traffic contracts they were not in this action challenged by any party who had shown any right to interfere with them. With respect to the "winding up act" of 1886, so far as it attempts to close the ear of the court to any evidence except such as the receiver may permit to be heard, and directs in advance the sort of judgment the court should thereupon render, it is unconstitutional, as being a perversion of the due process of law, which the constitution guarantees to all suitors; and hence the provision for the adjustment of claims before the receiver is void.

The prevailing opinion is written by Justice Landon. Presiding Justice Learned writes an opinion to the effect that the repealing act of 1886, whereby the Broadway Surface Railroad Company was declared annulled and its charter repealed, is unconstitutional and void; also that the appointment of the receiver without notice to the company or its directors was void. He concurs, however, in the affirmation of the judgment.

Corporation Counsel O'Brien has written an opinion in which he holds "that the elevated railroad company has no authority to place the stairways from their stations in the cross streets below Fourteenth street or east of Sixth or Ninth avenue in cross streets above Fourteenth street. He also states that the construction of stations of wood is a violation of the building law." If these are really violations, they have existed five or six years without serious detriment to the interests of the city or to any individual, certainly there should be no haste in the attempt to remove these structures, which could not be done without interruption of business and needless legal wrangling.

Corporation Counsel O'Brien says that the Second Avenue Railroad Co. is assessable for the expense of paying its roadway including two feet outside of the tracks from Ninety-second to 109th St. on First avenue.

"Mr. Loew had better investigate this thing," says an officer of the Broadway and Seventh Ave. R. R. Co., in reply to the charge that the conductors do not ring up to register the transfer tickets which they receive from passengers, "before he talks about it. The transfers are all recorded. The cross-town lines pay our company for carrying the passengers, and the sum goes into the gross receipts, of which the city receives its percentage. If the company choose not to register anything but cash fares, it is their own business." The number of transfer tickets used in February was 25,659; March, 42,955; April, 54,627; May, 62,284; June, 79,243; July, 91,208.

The report of the Rapid Transit Commissioners was sent to the Mayor and made public September 20. The commissioners were appointed to lay out a route for a steam railway "from a point on the easterly line of Broadway, near the City Hall Park, to a point of junction with the authorized line of the New York Underground Railway company south of Fourteenth street." The commissioners, after resolving that there is a necessity for such a railway, decide that they have no power to lay out the route and so report to the Mayor. In their report they say: "We are prohibited by the express terms of the law from extending such road in either direction necessary to give rapid transit. In this we are confirmed by the opinion of the counsel to the corporation. We accordingly decline to accede to the request. After calling the Mayor's attention to the laws in question the commissioners say: "Your honor will see that it is evident that nothing can be done to give the city further rapid transit until the Legislature sees fit to remove in whole or in part such prohibitions as now exist." They then go on to give their own ideas as to what should be provided in the way of rapid transit for this city, as follows: "We are led to the conclusion that there is but one way to obtain rapid transit, and that is by the construction of a solid viaduct line through the blocks, as far as possible, and when compelled to cross or follow the lines of streets to be constructed

with much greater strength and solidity than the present elevated railroads. Such a viaduct road should be built in accordance with the following conditions: First—The structure should be built through the blocks of brick and stone in the most solid manner. The streets should be crossed by massive steel girders, with solid steel floors, having no openings. The track should consist of heavy steel rails on ties laid in an elastic material between floor and ties. There would be no jar or break of continuity of motion in such a structure, and trains could be run at a high speed with little noise. Second—The stations should be not less than one half mile apart and long enough for ten cars. The cars should be as wide as possible. Third—Trains should be run by independent motors and as frequently as on the elevated roads, and at a speed of at least twenty-five miles per hour, including stops. This would enable the trip to be made"—  
Distance. Time.

From Wall street to			
City Hall.....	½ mile	1¼ to	1½ minutes,
Union Square.....	2 miles	5 to	6 minutes,
Madison Square.....	2½ miles	6 to	7 minutes,
Forty-second street.....	3½ miles	9 to	10 minutes.

The Fifth Avenue Transportation Co., Ltd., whose route is on Fifth Ave., from Bleecker street to 89th street, have 60 omnibusses, with 437 horses, gratifying the riding propensities of the wealthy dwellers and visitors on that strip of the Empire City. The company will import some English 'busses. This departure seems due to the fashionable demand for outside accommodation. The 'busses in question will carry eighteen people outside.

A call for a special meeting of the stockholders of the Third Avenue Railroad has been issued, to be held on October 31, "for the purpose of authorizing the issue by the company of its bonds for the purpose of retiring, paying and consolidating its existing debts and obligations and of providing for the construction and equipment of a cable railway and for other purposes, and of authorizing the securing of such bonds by a first mortgage upon the properties, franchises and incomes of the company." The call for the meeting is significant as showing that a cable has finally been settled upon as the means of more rapid surface transit. The road is once more on a dividend-paying basis, but the rapid growth of the East Side, above Central Park, together with the competition of the elevated roads and the loud public demand for increased facilities, impels the surface road to take this step.

*Pelham.* The Pelham Park RR. Co. will put on two additional cars and five horses.

*Rochester.* The matter of the application of the Rochester City and Brighton railroad company for a franchise to extend lines in the city was taken up, September 21st. Permission was asked and granted to withdraw the application, "inasmuch as the steps taken by the common council have made it impossible for the company to bid for a valid franchise." It is probable that the courts will be resorted to in the matter.

A comparison of the list of directors of the Rochester City and Brighton road with the stockholders of the new West-side and Northside roads show some interesting facts. The directors of the Rochester City and Brighton company, as named in its last annual report, are George Ellwanger, C. B. Woodworth, Patrick Barry, James M. Whitney, C. C. Woodworth, William C. Barry, Charles F. Pond, William D. Ellwanger, John H. Barry, William G. Watson, Charles S. Baker, F. E. Woodworth and Charles P. Barry. The West-side road was incorporated on the 6th of last August. The stockholders mentioned in the articles of incorporation are W. D. Ellwanger, J. M. Whitney, C. C. Woodworth, John Alexander, Charles F. Pond, F. E. Woodworth, C. B. Woodworth, William C. Barry, George H. Ellwanger, Charles S. Baker, Charles P. Barry, William G. Watson and Joseph S. Hunn. This company wishes to construct a road from the rapids to the boulevard. The Northside company has the same list of stockholders except that Patrick Barry and George Ellwanger are substituted for Charles F. Pond and Joseph S. Hunn. This company desires to build a line from Church street to Bay street. The articles of incorporation

were filed on September 13th. It will be noticed that nearly all the stockholders of both the Northside and Westside companies are also prominently identified with the Rochester City and Brighton company.

The street railway ground here is still covered with injunctions. The electric company will probably bid on the line from the rapids to the boulevard. There has been an effort to arrive at an understanding between the electric company, the old company and the directors of the boulevard about the laying of a track on the boulevard and the time in which to answer the complaints has been extended in all the actions. Either some arrangement will be arrived at between all the companies or steps will be taken to vacate the injunctions restraining the laying of tracks on the boulevard. It is now getting too late to build railroads this fall.

*Utica.* The Oneida St. RR. Co. have only a mile and half of track in operation, but they expect to extend their road nearly three miles south, one mile north, and about three-quarters of a mile west. And they are one the *qui vive* for developments in electric locomotion.

#### OHIO.

*Cincinnati.* The Vine Street Cable Company have one engine erected, and three boilers *in situ*; and recently they sent a car over the entire route to the great delight of a large number of spectators. The engine house is not yet built, but work is progressing as rapidly as possible. Mr. H. M. Lane, M. E., is the constructing engineer.

The Mt. Auburn Cable Railway Company is now finishing on "Cheapside" double crossings for the two cable roads at Fifth and Sixth streets. They are made of the heaviest angle iron and chilled wrought iron and steel. They each weigh about six tons, and were cast in Pittsburgh at a cost of about \$2,000 apiece. The company is also constructing a switch for throwing cars from either the power-house to the Avondale branch or from the branch to the main-line, or vice versa. This has been a very difficult piece of mechanism, but has been successfully accomplished, the turns being nicely adjusted to the gauge of the car. When the cable is to be inserted in the conduit half of it will be hauled to the power-house and then attached to the drum, by which the other half will be drawn up by machinery, thus saving half the hauling.

The Mt. Auburn cable will run under the Walnut Hills cable at the crossing, and a sheave will be inserted to protect the two cables from interfering with each other. The conduit of the Mt. Auburn line at the crossing is about three inches lower than that of the Walnut Hills line.

An ordinance was presented to the Board of Public Affairs, Sept. 28th, to grant the Mount Auburn Cable Railway Company the right to occupy Fourth street between Sycamore and Walnut streets. The Martins, father and son, were present in person to press the passage of the ordinance, and Judge Taft, Judge Smith and Ex-Governor Noyes representing Mount Auburn, were also in attendance for the same purpose. The matter was not settled. The knotty question to be solved is whether the Mount Auburn or the Consolidated Company shall be given the "first whack" at a cable conduit on Fourth street. The senior Martin, president of the Mount Auburn Cable Company, stated that that corporation is willing and ready to construct the conduit and share its use with any other company desirous of traversing Fourth street between the points named. He guaranteed that two cables can be operated in the same conduit, and pointed to precedents of such an arrangement.

A portion of the second floor of the two-story brick annex to the Cincinnati Street Railway Company's Brighton stables, on Harrison avenue, just west of the intersection of Central and Colerian avenues, gave way about half past ten o'clock on the night of Sept. 20, as a result of the tremendous weight of corn which had been piled upon it. The falling beams and grain completely buried about ten horses which were stabled on the floor below. The barn at which the accident occurred was partly burned down on May 27, as reported in the June GAZETTE. Recently it was rebuilt. The lower floor of the extensive structure is utilized as a stable, in which 353 horses were kept. On the upper floor the feed was kept. In the south end of the building, on the floor re-

ferred to, was a quantity of grain which had been piled five feet deep. The weight of the enormous accumulation of grain was too much for the wooden rafters, and this crash was the result.

*Cleveland.* The Garden Street Ry. Co. is not meeting with the least prospect of success, we are told. Its novel and high-sounding resolutions were passed with the view of "inducing" the East Cleveland R. R. Co. to do what they "resolved" to do—paving the whole street, etc. The East Cleveland R. R. Co. has a franchise already for the street in question.

At the Board of Improvements, Sept. 23, there were none of the lively street railway "discussions," such as have lately taken place, and the meeting proceeded smoothly. The Garden Street Ry. Co. petitioned for the right to operate a railroad through Garden and Ohio streets and Woodland avenue, Ontario street, the Square, and Superior street. As this will probably bring another fight upon the carpet, the board postponed consideration of the subject for one week, when it will be made the special order of business.

The Board sanctioned the proposal of the Brooklyn Street R. R. Co. to connect their Pearl street and South Side lines by way of the Abbey street branch of the Central viaduct.

Moved by the recent scenes in the board meetings during the street railroad discussions, Mr. Carpenter introduced a resolution appointing Sidewalk Inspector F. H. Wallace sergeant-at-arms for the purpose of keeping the board room clear inside of the railing. The resolution was adopted.

#### PENNSYLVANIA.

*Allegheny.* The directors of the Pittsburgh, Allegheny and Pleasant Valley Passenger Railway Company intend to afford an outlet for the growing city in the direction of Jack's Run, about five miles from the city hall. An ordinance giving the company the right to continue their tracks past the first toll gate and along the New Brighton road to the Bellevue Cemetery, is now before the city council. And a correspondent says that, "as is already the case with the directors of almost every horse car railroad in existence, those of the Pleasant Valley road have come to the conclusion that electricity will out-trot horses in the near future, and either a cable or an electric road will undoubtedly take the place of the present horse line." The first part of the extension will be carried out along the New Brighton road from the point where the line now diverges into Brighton Place. This will be about half a mile of new track.

The Observatory Hill Pass. Ry. Co. intend extending their track about a mile, across the Allegheny River into the city of Pittsburgh.

*Bellevue.* The electric railway is to be operated from a 100 horse-power engine, the contract for which has been awarded to the Westinghouse Machine Co.

*Norristown.* The Norristown Pass. Ry. Co. will add three or four miles of new track "probably within a month."

#### TENNESSEE.

*Memphis.* The East End Railway Co. contemplate further extensions.

#### VIRGINIA.

*Charlottesville.* The Charlottesville & University St. Railway Co. are building new stables, car shed and office. A number of new cars are under contract.

*Staunton.* Messrs. A. D. Payne and Moses Leterman, of Charlottesville, are applicants for a franchise to build and operate a street railway at Staunton.

NOTE: Charlottesville is 97 miles distant (by rail) from Richmond, the capital of the "Old Dominion." And Staunton is sixty miles further west.

#### WISCONSIN.

*Madison.* The Madison Street Railway Co., with its two miles of track, operated by eight cars, with four horses and twenty mules, does not give satisfaction to the citizens; and extensions and improvements are imperative. Hon. D. K. Tenney, of Chicago, president of the company, with Vice-President Keyes, have told the City Fathers that the line has been a complete failure financially. They said: "Blood cannot be got out of a turnip. The company from its inception have lost in operating the road \$200 a month."



# The Street Railway Gazette.

VOL. II.

CHICAGO

NOVEMBER, 1887.

NEW YORK

NO. 11

## Charles Butler Holmes, Esq.

PRESIDENT OF THE AMERICAN STREET RAILWAY ASSOCIATION.

The second annual meeting of the American Street Railway Association, held in Chicago in 1883, was marked by the reception of the Chicago City Railway Company into its membership; the company's president and superintendent, Mr. Charles Butler Holmes, being its representative. The Chicago City Railway is famous the world over as being one of the best managed street railways known, and especially for the great success of its cable system of propelling the cars.

It was in January, 1882, that the first train of cable cars was run in Chicago, consisting of ten cars drawn by one grip car, and containing a thousand passengers. While the cable had been used for some time previously, to a limited extent, in San Francisco, it was now for the first time put to the test of an enormous traffic, and the still greater trial of snow and ice. Over twenty miles of cable track was soon built, and all operated from one central power station. Another section of the company's extensive horse railways was afterward converted into cable, with a separate engine house. Other independent power stations, and long lengths of cable lines, are now in course of construction. The most convenient means of rapid transit, thus provided, is highly appreciated by the public, and the greatest honor is due to Mr. C. B. Holmes for all this, for it was principally through his foresight and courage that the plans of this undertaking were successfully carried out, while most people predicted sure failure.

Not only are Mr. Holmes' talents appreciated in Chicago, but he stands so high in the estimation of the American Street Railway Association, that they have elected him as their president for their current fiscal year at the convention recently held at Philadelphia. It may be specially interesting, therefore, to give a brief sketch of Mr. Holmes' career.

Charles Butler Holmes was born in Springfield, Vt., March 18, 1840. His father was the late Rev. Henry B. Holmes, and his mother was Harriet Butler Holmes,

daughter of Judge Butler, of Stuyvesant on the Hudson. When quite young his parents moved to Massachusetts, and for some eight years lived in Andover, where the son was educated in Phillips Academy, leaving school at sixteen years of age, to try his fortunes, and make his own way in the West.

Having studied surveying, he found many calls for his services in the then wild West, and spent one season in railroad engineering. He worked on a farm, taught school, and carried the compass until twenty-one years of age, when

he married Miss Eliza J. Robinson, of Cherry Valley, and settled down to farming and stock raising; but his wife's health failing, he came to Chicago, in 1863, and after a few months took charge of the Union Line Transportation Co., then operating three steamboats and fifty canal boats in supplying the army with grain and provisions.

After winding up the affairs of that company, Mr. Holmes was elected superintendent of a coal mining company, and continued in that business for seven years.

In the beginning of 1873 he was elected superintendent of the Chicago City Railway Company, and has retained the position ever since. In the beginning of 1882 he was called to the presidency of that company, and has since filled both positions. His wife died in 1880; and about a year later his youngest son, then nine years of age, died. Mr. Holmes has two sons living, now 18 and 16 years of age respectively. He was married in 1883 to Miss Kate K. Raworth of Chicago, and has since lived on Prairie Ave. at 30th street.

One can know but comparatively little of the real Mr. Holmes from the foregoing record. In the last GAZETTE, and in previous issues, references have been made to the splendid harmony that exists between President Holmes and the very numerous staff of conductors, gripmen, drivers, as well as officials of the Chicago City Railway Co. But to find out the whole man, we had to turn our faces from the South Side, and wind our way to Clybourn Avenue, in the northern part of the city. There in a fine building, 100 ft. by 99 ft., one recent Sunday afternoon, we found between two and three thousand children, arranged in appropriate groups, receiving instruction under the superintendence of Mr. Holmes. It was a grand



*C. B. Holmes.*

sight. The total number of scholars on the roll is over five thousand! Harper's *Young People* (May 10, 1887) declares that it is "the largest Sunday school in the world," and to that paper we refer those who desire more information. We may observe that the same tact and talent which has succeeded in building up and operating the extensive Chicago City Railway, is readily traceable in the management of the great Sunday school. The paper to which we have referred says: "The exercises move along like a well-regulated express train, and the reading and singing alternate without the loss of a moment's time. No books are used in this Sunday school, for the songs are painted in big letters, that may be read a block distant, on great sheets of heavy paper as large as a door—one verse to a page—and hung on a big easel. As fast as a verse is sung the sheet is turned over. And such singing! it is an inspiration in itself."

### The Sixth Annual.

We have been to the Convention

Of the great street railway men,

And have heard of each invention

They discussed—eight, nine or ten;

Foremost came the car electric,

With the storage batteree;

Reckenzaun being most magnetic,

With his motors, two or three.

William Wharton read a paper

On the strange electric force,

Which is used as motive power

For propelling the street cars.

Calvin Richards gave a welcome

To this "child" from angels' land;

And to it, in manner handsome,

He held out a helping hand.

F. J. Sprague, the electrician,

Next appeared upon the stage,

And in reference to this question

Showed advancement of the age.

Then the theme was not exhausted,

But continued the next day;

And great interest there existed

In what each one had to say.

One of th' interesting speakers,

And the liveliest, on the whole,

Is well known to our readers,

Namely, Chas. J. Van Depoele.

Mr. Blackwell joined discussion

And spoke well for Bentley-Knight.

Ending came adhesive traction,

By Elias Ries, just right.

There were plenty other subjects,

Road construction and the rail;

And adjoining were exhibits

Which were shown us without fail.

Fire insurance, motors various,

Were discussed, and papers filed;

Everybody were harmonious

Until Mr. G. got roiled.

Philadelphia's great Convention

Thus came nicely to a close.

And the Capital of the Nation

For next Annual they chose.

'Thanks to Thomas W. Ackley,

Who performed his duties well—

No confusion and no medley—

With such care that none can tell.

And the Secretary's kindness

Helped proceedings to run straight;

Ruling legal points with aptness,

Showing that his skill is great.

Then Dougherty's great oration

At the banquet made us burn,

Till we're filled with admiration.

As now to our Holmes we turn.

## SIXTH ANNUAL CONVENTION

OF THE

## American Street Railway Association.

The Sixth Annual Meeting of the American Street Railway Association was held at the Continental Hotel, Philadelphia, on Wednesday, October 19, and following day, under the presidency of Mr. Thos. W. Ackley. The attendance at the opening session (Wednesday morning) indicated unusual interest in this year's Convention. The number present was large, and the reading of the paper on "Electricity as a Motive Power" particularly was listened to with wrapt attention.

The President, in calling the Convention to order, announced that the first business was to call over the roll of membership. This was done by the secretary, Mr. Wm. J. Richardson. The members are indicated by an asterisk (\*) prefixed to their names in our Directory Supplement. The following is a list of delegates, with the names of companies they represented:

Edward G. Mosher, Gen'l Manager Augusta & Summerville R. R. Co.

Nelson Perin, prest.; Albert G. Clark, director; Baltimore Union Pass. Ry. Co.

Chas. E. Powers, prest.; Julius E. Rugg, gen. supt.; Jno. H. Studley, supt.; Jno. A. P. Martin, director; Boston Consolidated Street Railway Co.

Calvin A. Richards, prest. Metropolitan Ry. Co.  
Daniel Coolidge, supt. South Boston (West End) R. R. Co.

Albert Eames, prest.; B. F. Lasher, gen. supt.; Bridgeport Horse R. R. Co. (Conn.).

William Richardson, prest.; Wm. J. Richardson, sec.; Atlantic Avenue R. R. Co. of Brooklyn.

Daniel F. Lewis, prest. Brooklyn City R. R. Co.  
John N. Partridge, prest. Brooklyn City & Newtown R. R. Co.

Henry M. Watson, prest. Buffalo Street R. R. Co.  
Prentiss Cummings, prest. Cambridge R. R. Co.

Henry H. Windsor, sec.; Thos. C. Pennington, treas.; Chicago City Ry. Co.

E. V. Cherry, director, Cincinnati Inclined Plane Ry. Co.

John Kilgour, prest. Cincinnati Street Ry. Co.  
A. Everett, prest.; Henry A. Everett, sec. and treas.;

East Cleveland R. R. Co.  
J. B. Hanna, sec. Woodland Ave. & West Side Street R. R. Co.

Moses Humphrey, prest. Concord Horse R. R.  
A. W. Anderson, supt.; C. B. Clegg, director; Dayton Street R. R. Co.

W. W. Bean, prest. Newport & Dayton Street Ry. Co.  
B. F. Longstreet, director, Denver City Ry. Co.

Sidney B. Miller, prest.; S. Hendrie, sec.; Jno. H. Fry, auditor; Detroit City Railway.

Geo. S. Hazard, supt.; James H. Vhay, ———; Fort Wayne & Elmwood Ry. Co.

Henry A. Sage, prest. Easton, South Easton & West End Pass. Ry. Co.

Henry A. Willards, prest.  
Morris C. Fitch, prest.; Walter A. Jones, vice prest.;

Thos. Hodge, director; Gloucester Street Ry. Co.  
E. S. Goodrich, prest. Hartford & Weathersfield Horse Ry. Co.

Chas. B. Thurston, prest. Jersey City & Bergen R. R. Co.

V. Cronyn, prest. London St. Ry. Co. (Canada).  
H. H. Littell, gen. manager, Louisville City Ry. Co.

R. Dudley Frayser, sec. Citizens' Street R. R. Co. (Memphis).

R. Dudley Frayser, prest. Memphis City Ry. Co.  
Winfield Smith, prest. Cream City R. R. Co.

Chas. Odell, prest.; Thos. H. Johnson, director; W. B. Ferguson, supt.; Newburyport & Amesbury Horse R. R. Co.



C. Densmore Wyman, vice prest. Central Park, North & East River R. R. Co. (New York).

H. Edward Bedfill, director Harlem Bridge, Morrisania & Fordham Ry. Co.

Thos. H. McLean, sec. Twenty-third Street Railway Co. (New York).

Benjamin Flagler, prest.; Arthur Schoellkopf, gen. manager; Niagara Falls & Suspension Bridge Ry. Co.

W. A. Smith, supt. Omaha Horse Ry. Co.

D. F. Longstreet, vice prest.; E. N. Littlefield, treas.; Pawtucket Street Ry. Co. (R. I.).

Thos. C. Barr, sec.; Edward Samuel, director; Lombard & South Street Pass. Ry. Co. (Phila.).

John B. Parsons, prest.; Wm. Wharton, Jr., engineer of construction; People's Pass. Ry. Co. (Phila.)

E. B. Edwards, prest. Ridge Avenue Pass. Ry. Co. (Phila.).

Thos. W. Ackley, prest.; Wm. R. Warner, B. S. Kunkle, directors; Wm. Penn Cooper, gen. supt.; Thirteenth and Fifteenth Streets Pass. Ry. Co. (Phila.).

Wm. McCreery, prest. Federal St. & Pleasant Valley Pass. Ry. Co. (Pittsburgh).

Chas. Atwell, prest. Pittsburgh, Alleg. & Manchester Pass. Ry. Co.

D. F. Longstreet, vice prest. Union R. R. Co. (Providence, R. I.).

Benj. F. Owen, prest.; Jas. L. Douglass, vice prest.; — Talheimer, director; Reading City Pass. Ry. (Pa.).

C. C. Woodworth, sec.; C. B. Woodworth, treas.; Rochester City & Brighton R. R. Co.

Chas. Odell, prest.; Rufus H. Brown, director; Naumkeag Street Ry. Co.

— Moss, sec. Sandusky St. Ry. Co. (Ohio).

James H. Johnston, prest. City & Suburban Ry. Co. (Savannah).

A. E. Smith, treas. Springfield Street Ry. Co. (Mass.).

Julius S. Walsh, prest. Cass Avenue & Fair Ground Ry. Co. and Citizens' Ry. Co. (St. Louis).

Wm. D. Henry, sec. and treas. Missouri Railroad Co. (St. Louis).

Chas. Green, prest. People's R. R. Co. (St. Louis).

Joseph S. Minary, sec. Southern Ry. Co. (St. Louis).

John E. Bailey, prest.; Daniel E. Bailey, director; John G. Croxton, stockholder; Toledo Consolidated Street Ry. Co.

Geo. W. Kiley, director, Toronto Street Ry. Co.

Wm. H. Skirm, vice prest.; Chas. Y. Bamford, treas.; City Ry. Co. (Trenton, N. J.)

Chas. Clemmshaw, prest.; Chas. H. Smith, supt.; Troy & Lansingburgh R. R. Co.

Henry Hunt, prest. Washington & Georgetown R. R. Co.

Wm. J. Harvey, prest. Wilkesbarre & Kingston Pass. Ry. Co.

Wm. Canby, prest.; Jno. F. Miller, sec.; Geo. H. Bates, director; Wilmington City Ry. Co.

Chas. Hathaway, sec. St. Clair St. Ry. Co. (Cleveland).

#### NEW MEMBERS.

Fitchburg St. Ry. Co., Fitchburg, Mass.

St. Clair St. Ry. Co., Cleveland, Ohio.

Pavonia Horse R. R. Co., Jersey City, N. J.

President Thos. W. Ackley delivered the

#### PRESIDENTIAL ADDRESS.

#### Gentlemen of the Convention:

I congratulate this association upon the large attendance of its members and delegates at this meeting. It is an evidence of the great interest felt in the deliberations of this body of intelligent railway managers, an assurance of fraternal feelings and cordial greeting in coming together from the far and extreme sections of the United States and Canada. Each one can contribute and become an important factor in the prosperity of the cause in which we are engaged. When once in operation the street railway of the period becomes an indispensable necessity, an important auxiliary in the growth of towns and cities, a medium by which distance is overcome, a guarantee of prosperity to follow, the people's benefactor.

This association, although moderately new in its formation, this being the sixth annual session, shows thrift with rapid advancement by the large accessions to its membership. The enterprise in which we are engaged is one of endless study, representing as it does the carrying of passengers by street surface railways, and with new inventions and new

ideas forcing themselves upon us, compels progressive action, which is essential to success in our business. The public, our patrons, seldom if ever satisfied with the accommodation given them by the carrying companies, spur us to a greater sense of duty and energy in catering to their demands. The present and future of street railways suggest as a field of thought for their better management, more rapid and safe carrying of its patrons.

The free interchange of experience and discussion of subjects relative to passenger conveyance should produce handsome results. As your presiding officer I ask the fullest, freest expression upon the various interesting topics that will be brought before you. Let no one hesitate or withhold his experience in railway management, thereby exerting his influence for an improving standard of our business. After the several reports upon special subjects shall have been read and discussed, an opportunity will be given for the introduction of new matters. The tendency during the past year has been the development of some economical power other than horses for the propelling of street cars. In this city the cable system can be seen in operation, the electric storage battery system will be shown you with a practical exhibition of its workings, with some probability of other motors being exhibited of novel construction.

The labor question, which threatened a revolution in railway management, has, to a great extent, subsided, the employer and employee working again harmoniously. The business of the year might be summed up as generally prosperous, with indications for the future full of encouragement for like results.

By the report of your able treasurer will be shown the financial condition of your association.

Let each of us, at the close of this conference, carry with us back to our scenes of labor a feeling that it has been both profitable and entertaining to have been here. I commit the business of the convention to your better judgments. Let us in our deliberations be actuated by motives of public benefactors, that we can go before the world, our patrons, with the congratulation of "Well done, good and faithful servants."

#### EXECUTIVE COMMITTEE'S REPORT.

The Executive Committee's Report was read by the Secretary, as follows:

#### Membership.

The Association at the commencement of the meeting in Cincinnati had a membership of one hundred and forty companies. At that meeting and during the year the membership has been increased by the following companies, making, with the changes noted in the succeeding paragraph, a total of one hundred and fifty-three companies now members of the Association:

Chicago Passenger Railway Company, Chicago, Ill.  
Lincoln Street Railway Company, Lincoln, Neb.  
Galveston City Railway Company, Galveston, Texas.  
Citizen's Street Railroad Company, Memphis, Tenn.  
Augusta & Summerville Railroad Company, Augusta, Ga.  
Metropolitan Street Railroad Company, Kansas City, Mo.  
College City Street Railway Company, Galesburg, Ill.  
Wilmington City Railway Company, Wilmington, Delaware.  
Canal & Claiborne Street Railroad Company, New Orleans, La.  
City & Suburban Railroad Company, Savannah, Ga.  
Canton Street Railway Company, Canton, Ohio.  
Hastings Improvement Company, Hastings, Neb.  
Sandusky Street Railway Company, Sandusky, Ohio.  
Mobile Street Railroad Company, Mobile, Alabama.

#### Changes in Names.

The following changes in the names of members have taken place: The City Railway Company of Memphis, having been consolidated with the Citizen's Street Railway Company, both members, the former is merged in the latter under one membership. The New Bedford and Fairhaven Street Railroad Company, of New Bedford, Mass., at the time a member, was consolidated with the Acushnet Street Railway Company, of the same place, forming the Union Street Railway Company, which latter company has been substituted in place of the first named. The East Saginaw Street Railway Company, of East Saginaw, Michigan, has changed its name to the Union Street Railway Company of East Saginaw. The Washington Street and State Asylum Railroad Company of Binghamton, N. Y., has withdrawn, and the City Railway Company of the same place has taken its place. The Oakwood Street Railway, of Dayton, Ohio, has withdrawn.

#### Legal Opinions.

The following legal opinions have been issued, with more or less regularity covering the entire year, and inclusive of September and October, 1886, which at that time of the last meeting had not then been issued:

1886.

September—Lewis H. McDade against Washington and Georgetown Railroad Company.

October—Columbia & Cincinnati Street Railway Company against S. V. Wiseman.

November—The City of Cincinnati against The Columbia and Cincinnati Street Railway Company.

December—Portland and Williamette Valley Railroad Company against the City of Portland.

1887.

January—The New York Cable Company against the Mayor of the City of New York and others.

February—The Corporation of the Borough of Easton against The Easton and South Easton and West End Passenger Railway Company.  
 March—Galveston City Railway Company against James M. Hewitt.  
 April—George Lahr against The Metropolitan Elevated Railroad Company.  
 May—Charles G. Rochat, Ad'mr. against The North Hudson County Railway Company.  
 June—Des Moines Street Railroad Company against Des Moines Broad Gauge Street Railway Company.  
 July—John Harmon against The Washington and Georgetown Railroad Company.  
 August—Coast Line Railroad Company against Mayor and Aldermen of the City of Savannah.  
 September—James N. Carpenter against The Washington and Georgetown Railroad Company.  
 October—City of Waterloo against Waterloo Street Railroad Company.  
 The Committee takes this occasion to express the desire that the individual companies would manifest greater interest in this feature of associational work; it being vital, and the value of the information derived from important street railway decisions can not be overestimated. We ask that each company will send promptly the opinion of the court in any case in which it may be interested.

#### *Street Railway Fire Insurance.*

An effort was made by the American Street Railway Mutual Fire Insurance Company, whose directors, to the number of fifteen, it will be remembered, are representative street railway men throughout the country, to have its capital reduced from \$500,000, to \$200,000. It was not successful; but there is reason to believe that it will be during the coming legislative session in the State of New York. It will then, undoubtedly, be in a position shortly thereafter to undertake to insure street railway property. It is believed that all that is necessary to its successful development is that it be in the hands of a thoroughly competent and efficient fire insurance man, who fully understands the business. The men who would have charge of its financial affairs, being the officers of leading street railway companies, and prominently known to the gentlemen interested in this association, would inspire confidence, and it is believed receive hearty support, and lead to a successful business of the company. When the Company is ready to do business, we heartily commend its support by the street railway companies of America, inasmuch as we firmly believe from facts hitherto elicited direct from the companies, that street railway insurance is fifty per cent. higher than it should be, while the moral risk of the property is of the highest order, and the fire risk one of the safest.

#### *Street Railroad Taxation.*

Street railroad taxation, which was commented upon in the report of the last executive committee has not, as yet, been in anywise materially effected by legislation. Taxed in every conceivable way, a grievous burden is laid upon the companies. A united and determined effort by all honorable means should be made to endeavor to lighten these excessive burdens. The people are more benefitted by the lowest possible fare, than by the highest possible taxation.

#### *Knights of Labor.*

During the last fiscal year of the association the Knights of Labor have not, to any considerable extent, disturbed the business prosperity of the country, at least, so far as annoying the street railway companies is concerned, by "strikes" and the constant violent interference with the running of the cars. In one or more individual instances, however, the companies have been grievously and unjustly interfered with in the prosecution of their business. This has been done without rhyme or reason, and to the ultimate discomfort, not to say defeat, of the Knights of Labor engaged in these "strikes." We should not be considered egotistic when we say that we deal fairly with our employees, as between man and man, and are ever ready to listen to so-called grievances, complaints or differences that may exist in the minds of our men, concerning them in the management of our business. Willing to treat them justly, we should in turn be treated fairly; and are happy to record the fact that where local labor organizations are managed by broad-minded men, little or no inconvenience has been or need be experienced from the society in question. When, however unscrupulous or narrow-minded men are selected to come in contact with the managers of large corporations, the brief authority conferred is apt to be unwisely taken advantage of, to afford temporary notoriety, to the irreparable loss and detriment of their associates, who find out when it is too late that their confidence has been misplaced. In such cases these organizations are rather to be pitied. We believe that the improved intimacy existing between the employer and the employed has been a means of benefit to the companies in many instances. One thing is tolerably certain in America, namely, that a man will reach his level, if he be free to do so. Another thing equally certain, is, that the tendency of great combinations of labor is to drag down and handicap the skilled artisan. We believe there is sufficient wisdom in the managers of street railway companies to take of this enormous business, and as questions of labor in their different forms come before them, they will be able successfully to cope therewith.

#### *Union Internationale Permanent de Tramways.*

We are pleased to record the fact that there is in Europe an organization known as the Permanent International Union of Tramways, and of the desire on the part of that association, as expressed through its general secretary, M. Nonnenberg, to become informed of all matters of interest that concern the welfare of the American Street Railway Association. Copies of the reports of these associations have been exchanged; and any of the officers of the members of this association desiring to

inspect European tramways, when abroad, will undoubtedly be facilitated by the members of that association.

Notices of this meeting have been sent not only to every company that is a member of the association, but to all the companies in the United States and Canada, inviting representation at this meeting. We are pleased to note that, from the replies received, it is evident that at this meeting, as at every preceding meeting, large accessions to the membership will remain.

#### *Obituary.*

We take occasion at this time to note the demise of several who have been more or less prominently connected with the association:

WILLIAM H. HAYES was for many years president of the Eighth Avenue Railroad Company of New York City, and died suddenly at the end of a well rounded life. A kind father, a true friend, and an esteemed Christian gentleman, he was mourned by a large circle of friends and acquaintances.

JAMES W. FORSHAY was for many years president of the Broadway and Seventh Avenue Railroad Company of New York City. Under his able administration the business done by that company became of great magnitude. He was a hard worker, a genial companion, a sincere friend and a courteous gentleman.

GEORGE W. APPLETON was the auditor of the People's Passenger Railway Company of Philadelphia. That company writes of him: "It is with regret that we inform you of the death of George W. Appleton, after a brief illness. He was a man of ability and ripe experience, highly honored and esteemed in all the walks of life."

ROBERT BELL was the general superintendent of the Detroit City Railway Company. He was a man of action and good judgment; and the welfare of the company, as well as that of all those employed under him, was his continual care. He was a man without ostentation, and was admired most by those who knew him best. He passed away very quietly after a few days' illness.

It is with sadness that we make mention of the loss of these friends.

#### TREASURER'S REPORT.

The Treasurer's Report was presented by Secretary and Treasurer Richardson, who stated that, as the report had been submitted to the association and approved by a vote of the executive committee, he would, unless otherwise requested, omit the reading of it and make a mere statement of its substance. It showed a balance on hand, on Oct. 20th, 1886, of \$1018.07. A summary of the receipts showed that annual dues had been paid by 140 companies and admissions by 14 companies. From the sale of annual reports \$7 had been received, and from the sale of salt pamphlets \$2.40—the total of receipts amount to \$2459.40. The disbursements during the year, amounted to \$2022.81. Leaving a balance in bank of \$1454.66.

Mr. William Wharton, Jr., then read the report of the committee on

#### "ELECTRICITY AS A MOTIVE POWER."

Since the last annual meeting of this association the subject of using electricity as a substitute for horse power on street railways has received much attention, and great advances have been made in the practical application of it to that purpose, so that it may now be stated broadly there is no longer any doubt or uncertainty that electricity can be successfully and economically employed in a great many places, if not most places, as a substitute for animal power. Quite a number of electric railways are in operation in the United States, running satisfactorily under all the requirements of public service, so that there is much greater familiarity with, and a more general knowledge of, electricity among railroad men and the public than ever before. There is so much confidence in the practicability of electrical propulsion of cars being well established, that the subject is no longer treated with doubt or disdain; on the contrary, great interest and respectful attention are at once manifested whenever the subject is brought up. Although some parties, interested, perhaps, in pushing forward their own special inventions, may claim too much, the actual facts, as presented daily in the regular work of the cars, are good enough to warrant this belief and confidence. Electricity, in its manifestations, applications and capabilities, has been hitherto a subject the knowledge of which has been confined mainly to scientific circles, but it is evident that the time has come when it will be put in harness in place of the horse to draw cars, and to perform many other duties which a few years ago would have been considered entirely chimerical and visionary. So long as the oxidation of metals or other chemical action was the only available method by which electricity could be produced, the expense attendant upon such means limited its use to a very narrow sphere. Since, however, steam power and water power have been so successfully employed to generate electricity, and to do it so cheaply, the range of its usefulness and application has been wonderfully enlarged from year to year. It is not in ended in this paper to make use of scientific terms, or to discuss the question from any standpoint but that of practical observation and experience, nor is it in ended that any comparisons shall be drawn between electric motors and steam locomotives, but there is a wide field for work in which neither the locomotive or the horse is able to satisfactorily accomplish the duty called for.

The systems at present in use for electrical propulsion of cars are divided into two classes:

First, That in which the electricity is conducted from one or more active generating sources along a suitable conductor or conductors, to be used in the cars with proper return connections; and,

Secondly, That system in which the electrical power is obtained from accumulators or secondary batteries carried along with or within the body of the car. Of the first there are several methods, viz.: that



in which the electricity is carried along a conductor above the ground, considerably above the car, either directly over it or toward one side; that in which the electrical conductor is situated at the side of the railroad and elevated a few feet only above the ground; that in which the electricity is carried upon the surface, either by a third rail or other conductor, running on the level of the ground or pavement; and that in which the electricity is carried beneath the surface by a conductor placed within a suitable conduit for its protection, access being had to said conductor through a slot in the top of the conduit, so as to allow of electrical connection with the motor on the car.

The plans of having the conductor along the surface or at the side of the railroad, not much above the surface, have so many evident and practical disadvantages that they need not be taken into consideration in this paper; therefore the question is reduced to the three methods of overhead conduction, underground conduction, and storage batteries.

It is evident that better service must be furnished at the same cost, the same service furnished at a cheaper rate, or that both objects combined shall be attained by the use of electricity, before it takes the place claimed for it. The writer believes fully that the last proposition of both better and cheaper service has already been proved by actual service and daily use, but in the nature of things, improvements upon the present method will be discovered, and "the survival of the fittest," which applies as well to mechanical appliances as to animated life, will by its inexorable laws weed out and discard those which are deficient or incompetent. There are so many intelligent, persevering and scientific minds engaged in active experiments and researches into the mysteries of nature's powers, and more especially those relating to electricity, that discoveries are constantly being made, human knowledge in this age extending more rapidly than at any previous time. The subject is fascinating and the prizes sought after are brilliant and valuable. The increased cheapness in production of electricity which may fairly be assumed for the future, will of course add to the advantages and enlarge the scope of its use. At present there are many places where electricity can be generated at a nominal cost by the use of water power, and this energy can be carried a number of miles without any loss or leakage of practical consequence. Where this can be done, of course the parties have special advantages. So also there are many towns and cities in coal regions, or natural gas regions, where the same result of cheapness in production can be obtained, although by different means. As a case in point it may be mentioned that the electrical railway in Scranton, Pa., has its power station located about midway of the route, and immediately at the foot of a large hill or great mass of hundreds of thousands of tons of culm, which is principally composed of the small fine particles of coal produced in mining or left after the screening and preparation of the commercial sizes of coal for the market. This has been accumulating for many years, is still accumulating, and has hitherto been considered only an inevitable nuisance, which the mining proprietors would gladly have given away for nothing, to get rid of it, and not have it occupy their land. The price which the railroad company pays for this culm is but ten cents per ton, and as it only has to be wheeled through the door of the engine house, the whole distance from the culm hill to the furnace under the boilers not being over fifty feet, and as the whole consumption per day is on the average but five tons, or in money value but fifty cents per day, it is evident that the cost of electricity in this case is exceedingly small indeed, that sum being sufficient for the fuel to produce the steam power which generates electricity enough to run four and sometimes five cars, carrying at times seventy-five passengers each, over a railroad track about four and a half miles in length, having long grades, a number of which are five or six feet to the hundred, and the steepest of which is seven and a quarter feet per hundred. The tractive power required upon some of these grades is still further increased by curves or switches occurring upon them. It may be well to mention some other points about this railroad in Scranton, which has been running about one year, with great success, and exhibits in many respects a favorable example of an electrical railway with overhead conductors. The cars have four wheels; two of them are open cars, each carrying one motor of twenty horse power. The motor is placed in the body of the car midway of its length, and all four of the wheels are driving wheels, the connections between the motor and the wheel axles being made by means of chains and sprocket wheels. Three of the cars are closed cars, each with one motor of fifteen horse power, which is placed on a closed platform at the forward end of the car. In these the forward wheels only are driving wheels, and their connection with the motor is made in the same way as on the open cars, with chains and sprocket wheels. The company will shortly place four more cars upon the line, each with a motor of twenty-five horse power. These larger cars are intended not only to propel themselves but to be able each to haul in addition two other cars loaded with passengers up all the grades. The running time of the round trip on the main line, being in all eight miles, is one hour, which includes all stoppages and the waiting at each end of the route, so that the average speed attained is more than eight miles an hour. There is no difficulty in going much faster, in fact the men in control of the cars have to be watched to prevent their running at excessively high speed, particularly on the return trip to the city, where the grades allow the car to be run for the most of the distance by gravity alone. At the generating station there are two stationary engines of 180 horse power each, two dynamos of one hundred horse power each, and four boilers of one hundred horse power each. Only one engine and dynamo, however, and two of the boilers are in use at one time. The railway company expects also to furnish in the future electricity for the lighting of the town of Dunmore, situated at one end of the line, by which the income of the company will be materially increased. The duplicate engine and dynamo and the duplicate set of two boilers, are for the purpose of providing against contingencies of accident to those in use, and also to allow of al-

ternations in service, thus giving opportunity of frequent examination and inspection. Upon this railway, as before said, the overhead system of conduction is employed, having flexible connections between the motor on the car and the carrier traversing the conductor, which is a solid copper wire of five sixteenths inch diameter, suspended on a part of the route from transverse wires attached to wooden poles, placed on both sides of the street, about one hundred feet apart, usually about twenty feet and about six inches in the diameter at the surface of the ground, and on the rest of the line suspended from arms projecting sideways from wooden poles at the sides of the railway about twenty feet above the ground. The line is a single track railroad with several turnouts or passing places, at which points the electric overhead conductor branches off over the side track also, and an ingenious system is in use by which the carrier, running upon the overhead wire, with two grooved wheels of about two and a half inches diameter, automatically shifts the connections at the points of divergence from the main line, so that the carrier always follows that one of the overhead conductors which is above the track upon which the car is traveling. It is contemplated, however, to use two separate and independent overhead conducting wires throughout the whole length of the route, so as to avoid the possibility of any difficulty with the carriers at the points of interest on at the turnouts, although this has not happened often. The return current of electricity is taken by the rails. The electrical current has a tension of about six hundred volts, which, while sufficient to give a shock, could not produce any dangerous effect on man in case the current should by any means be diverted. Part of the road is laid with tram-ways and the rest with T-rails, and a part is paved and the rest unpaved, so that these different conditions, in connection with the many grades and the curves and turnouts, give ample opportunity to thoroughly test the working of the system. Although the overhead wires in this case do not present any more unsightly appearance than the numerous telegraph cables and wires to which we are so accustomed, it is, however, evident that the use of the overhead system will be prohibited in most cities and towns, especially since the general determination to place all electrical wires through cities underground. The noise of the carriers running on the conductors is not much, although it can be readily noticed, but the noise produced by the motors and the chain and sprocket connections, is quite considerable. This latter could be entirely avoided by the use of a noiseless motor and a better method of connection, of which motors and connections there are several kinds easily obtainable. Noiseless, efficient and durable electric motors, suitable for use on cars, can be had, in which the weight per horse power does not exceed sixty pounds.

In a paper of the length to which this must necessarily be limited, it will be impossible to do much more than treat of the subject in a general manner, but it can be stated specifically and certainly that electric railways with overhead conduction have demonstrated beyond a doubt their capability to propel a few cars, even if heavily loaded, at less cost and much greater speed than could be obtainable on railways operated by horse power. This is true in places where the coal required must be bought at usual rates, and the exceptional advantage of fuel at a merely nominal cost does not exist as at Scranton, and likewise at Wilkesbarre, where an electrical railway is under construction, upon which the cost of coal used will not exceed sixty or seventy cents per day for five cars.

In the case of electrical railways with underground conduction, the effort has been made to give all the advantages of the overhead system, and at the same time remove the objection, which in most places is absolutely prohibitive of having the conductors and poles or other supports obstructing the streets. In doing this, however, great difficulties arise, some of them of a very serious character. The costly conduit, with the needful arrangements for drainage and for cleaning out, together with the increased care necessary to provide against the considerable loss or leakage of electricity, which, nevertheless, generally takes place in spite of all precautions, detract greatly from the apparent advantages of the plan. Many inventions have been patented, and numberless devices contrived, to overcome the many objections of this method, but there is great room for doubt, whether practical success has yet been obtained.

Neither by overhead nor underground conduction have more than a few cars as yet been moved simultaneously upon railways although many ingenious arrangements are offered by various parties who confidently assert they can run any required number of cars. This, however, yet remains to be proved. Both plans also are open to another serious objection in the entire stoppage of travel on the whole line in case of breakage or derangement to any part of the conducting apparatus or the generating machinery. In this respect they are under the same disability as the cable system of car traction is hampered with. Possibly by suitable arrangements of duplicate engines, boilers and dynamos, duplicate conductors, and auxiliary, sectional or relay systems of conduction, this disability, threatening as it appears to be, may be so reduced as to be of no great detriment. This, however, also remains to be demonstrated. Taken altogether, underground conduction does not compare favorably with overhead conduction up to this time. One great trouble with the latter plan, however, is that although it can be used to great advantage and economy on lines running a few cars in towns, or in suburban districts, outlying large cities, it will probably never be allowed by the municipal authorities in large cities which of course are the very places where the advantages of electrical propulsion are needed the most. To move a large number of cars, as for instance upon the Third Avenue or Broadway lines in New York City, the electrical conductor whether overhead or underground must be of great size, if the current is of low tension; while on the other hand if a small or moderate sized conductor be used the current must then be of dangerously high tension, and of course, it would then be very difficult to avoid great loss of electricity from leakage.

There remains to be considered the accumulator or a secondary bat-

tery system. In this each car carries its own supply of energy, and is entirely independent of any method of continuous electrical conduction. No change of track or roadway is required, nor any costly conduit or unsightly poles or other supports, while the cars can run anywhere that a battery car can be taken by horses. These points are of immense advantage and are the chief merits advanced by its advocates, independent of its economy over horse power.

In practice, cars of the size of the usual two horse cars are provided with about 80 accumulators, weighing, when filled with fluid and ready for use, about 40 pounds each. These cells are placed under the seats, one half being on each side of the car. Their combined weight is 3,200 pounds, and the weight of two motors each of five horse power should not, together with their connections to the car axles exceed 800 pounds, so that the additional weight imposed upon the car is, say 4,200 pounds, which allows 200 pounds for the apparatus to control the current and for other electrical appliances. This added weight if placed upon a four-wheeled car may be of disadvantage to the car or to the track. If this should be the case, the difficulty is removed by the use of eight wheels on two swinging trucks, which support the car much better, and distribute the weight upon the track. Both these kinds of storage battery cars are in service with entire success. The charging of the cells is done by a dynamo driven by steam power or any other desirable means, and it takes four hours to charge cells which are able to perform four hours work. To remove from the car the cells which have done their work, and to replace them by freshly charged cells, takes no more time than the time required to change horses. It requires no horse power exerted for four hours to charge the batteries or cells of each car, so that 40 horse power hours are needed to accomplish it.

The cost of running large stationary steam engines of say, 200 to 400 horse power constructed with the modern improved cut off appliances and other economical devices, has been found, after extensive investigations, not to exceed two-thirds of one cent per horse power hour. This allowance is a liberal one and is above rather than below the actual average cost, including fuel at average market prices, attendance, repairs to engines and boilers, oil, etc. We will, however, take it at one cent per horse power hour: 40 horse power hours, at 1 cent cost 40 cents, which is the cost of four hours car service, and as the days work of a car should be taken as 16 hours we have as the whole cost a day's supply of electricity four times 40 cents or \$1.60. Since four teams of two horses are required to draw a car for 16 hours, and as one additional horse per car is the usual allowance for sick or disabled horses, nine horses per car are needed for a day's work, which at 50 cents per horse for feed, bedding, attendance, shoeing, etc., is \$4.50 as against \$1.60 for the storage battery electricity. Making extraordinary allowance for possible errors in this comparison, the difference is still astonishing to those who have not looked into the matter critically. With motors properly constructed a speed of eight or nine miles per hour is readily accomplished in fact eight miles per hour may be taken as the speed at which such motors will work to the best advantage and return the greatest percentage of mechanical efficiency. The requirements of street car service demand variable rates of speed, as for instance in crowded streets, behind other vehicles, or in turning curves and entering switches, it is necessary to go slowly and cautiously; and the weight of the load carried at different times will vary from an almost empty car to one overloaded. These conditions, together with increased power needed to ascend grades, and to start loaded cars, especially on up grades, call for electric motors, which will, under such greatly varying circumstances respond at all times almost equally well.

There are motors which while engaged in performing an equable work and running at an equable speed, for both of which purposes the motor was specially made, will return 90 or possibly 95 per cent efficiency, while the same motor when run at some different speed or under some different load may return but 30 or 35 per cent. So that the average performance of such motors in street car service would probably give only 50 per cent. return of efficiency. Motors can, however, be obtained which will under all the variations of street car work constantly return 75 per cent. of efficiency.

The durability of storage batteries is a point on which those interested in other systems are very prone to doubt, but it has been proved in actual use in cars that they will continue in good serviceable condition for 18 months or two years. Makers of these batteries offer to guarantee them good for two years of street car service. The lead lined wooden containing boxes will last for many years; the negative plates are good for more than two years; while the positive plates are certainly good for eighteen months if not more. The plates being of lead and lead oxide are still of value when they become unserviceable, for the metal can be recast into new plates, and the lead can be recovered from the oxide. The first cost of storage battery cars and the engine and dynamos is at present prices considerably more than the first cost of cars provided with suitable complement of horses and harness, but when the saving in first cost obtained by dispensing with the ground and the stables required for horses is taken into account, the balance will in many cases, be in favor of storage battery cars. This is, of course, applicable more particularly to large cities where ground is very valuable. By methods now being introduced into the manufacture of storage batteries, their production will shortly be made at a reduced cost, and their durability increased at the same time.

It should be remembered that the increased speed at which electric cars can travel is so much greater than horses could draw them, that two cars can readily do the work of three horse cars, especially as the electric cars require no time for resting at the ends of the route; but although they can easily do this, so much increase of speed would not be allowed or be practicable through the streets of most cities or towns. It could be done with safety and advantage through wide streets or avenues and

in suburban districts. It will, however, be perfectly safe to say that three electric cars can do the work of four horse cars, and if desired they can at the same time be of greater capacity than horse cars, for while the horses can do no more, no such difficulty exists with electricity. Without referring to the excessive first cost required for the expensive cable traction system, and comparing the first cost of the entire plant and equipment needed for a storage battery electric railway, on which three cars will perform the service of four horse cars, with the first cost of the entire plant and equipment of a railway, using horse power, it will be found that the advantage will in most cases be in favor of storage electricity.

Let us now compare the operating expenses:

Running expenses of 4 two-horse cars for one year, to wit:	
Conductors, 365 days, at \$3 each car per day of 16 hours.....	\$ 4,380.00
Drivers, 365 days, at \$2.50 each car per day of 16 hours.....	3,650.00
36 horses, 365 days, at 50cts. each per day .....	6,570.00
	14,600.00
One year's deterioration and repair of 4 cars at \$200 .....	800.00
One year's deterioration of 36 horses, at \$40 each .....	1,440.00
Total .....	16,840.00

Running expenses of 3 storage battery cars for one year, to wit:	
Conductors, 365 day, at \$3 each car, per day of 16 hours....	3,285.00
Drivers, 365 days, at \$2.50 each car, per day of 16 hours....	2,737.50
Electricity, 365 days, at \$2 each car, per day of 16 hours....	2,190.00
	8,212.50
One year's deterioration and repairs of 3 cars, including dynamos, storage batteries and motors, \$1,600 each .....	4,800.00

Total .....	\$13,012.50
This leaves a balance to the credit of the storage battery cars of .....	\$ 3,827.50

The fact of each storage battery car carrying within itself its own energy gives to the individual cars an independence of action which neither the cable traction plan nor the overhead or underground system of electrical propulsion possesses, for all of these depend upon central sources of power, which may at any time be interrupted, so that breakage or accident, to any part, involves the stoppage of the whole line. In a sanitary or cleanly point of view, the withdrawal of the car horses from our streets would be of great benefit, and this would be accomplished without having, as in the case of the cable railway, an open drain, which, although supposed to be kept clean, in fact, nearly always contains, deposit of street refuse to a greater or less extent.

The leakage of electricity in storage batteries, charged but not in use, need not be taken into account for any length of time that cars would probably stand idle. In fact, the leakage from batteries in good condition would not exceed ten per cent. in three months.

The percentage of mechanical energy given by the steam engine which is recovered in actual work under the variable conditions of street car service on the driving axles, with storage battery cars properly equipped is at least forty per cent. and with electricity by direct conduction at least fifty per cent. In cable traction, after deducting the power need to move the cable and to revolve the wheels guiding and carrying the cable, not over twenty-five per cent. is left for drawing the cars, and on some cable railways even less.

The increased speed so easily and advantageously obtained on electric railways, as a class, not only enables three cars to do the work of at least four horse cars, and effect the great annual saving shown above, but it has a tendency to invite travel and thereby increase receipts, also to give street railways the opportunity to extend their lines advantageously further into outlying districts, and to compete on better terms with elevated roads and steam railroads than would be possible with horse power.

The rapid deterioration and destruction of street car horses shows the exacting and terrible nature of their work, although it is only for four hours per day. Their powers are already overtaxed, and they can do nothing more in either speed or in load carried.

Electric cars by dispensing with horses allow more room in the streets for other vehicles, and this advantage in crowded streets is of moment. Take for instance Washington street, Boston, or Broadway, New York, and it will be readily seen that this relief to the clogged traffic would be great. Electric cars can go backward or forward with equal facility, they are under perfect control, can stop and start more quickly than horse cars, and in case of delay can make up lost time. They never get sick with epizooty or other disease, and during strikes or other periods of enforced idleness, do not require to be fed. On down grades they will run by gravity without the expenditure of other force, and on level or nearly level stretches, a very little electric energy continues them in motion when once they are started. The electricity besides running the motors, will supply the cars with incandescent electric lights, actuate a electric signal gong, and operate electric bells for the use of the conductor and passengers in stopping or starting the car. It is usual to have the regular hand brake for stopping the cars, but the motors can be instantly reversed by electricity, if desired. This method however should only be employed when it is necessary to stop the car quickly to avoid accident or for some other imperative reason. By this means the car be stopped in much less distance than is possible by the hand brake, which, of course, operates with the same efficiency whether upon electric cars or horse cars.

It has been questioned whether in winter when the tracks are liable



to be obstructed with snow or ice the electric cars will be able to propel themselves, owing to the fact that they obtain their power of propulsion from the adhesion of the wheels upon the rails, so that if the wheels are prevented from reaching the track there would be a great liability to the car slipping and turning around without giving any forward motion to the car itself. In answer to this, it may be stated that during last winter, on the electric railway in Scranton, having the overhead conduction system, and from experiments made in Philadelphia with a storage battery car, it was found that there was no unusual difficulty presented in snow storms, the wheels, owing to the added weight, settling more readily through the snow and thus reaching the rails. Upon roads properly equipped with snow plows, or snow sweepers with revolving brushes, propelled by powerful electric motors, the clearing of snow from the tracks would no doubt be much more efficient than horse power could effect. Street car electric motors of 50 horse power, or more, if required, can be as easily made and are as easily controlled as motors of five and ten horse power, so that electricity has ample ability to keep the tracks clear from accumulation of snow. As with locomotives, sand boxes should be placed upon electric cars, so that in any slipping of the wheels should be observed, either from the greasy, slippery condition of the track, sometimes seen in damp weather when the streets are not properly cleaned, or from snow or ice upon the track, the driver, by opening a suitable valve, can let out a little sand upon the rail and at once overcome the difficulty. It is sometimes asked why two motors of five horse power each should be needed upon a car usually drawn by two horses. In explanation of this, it may be stated that a car horse can, and very often does, exert for a short time, in starting a car or upon steep grades, a force of five or even more horse power. A mechanic 1 horse power is the measure of the moderate duty which a horse can constantly and regularly exert day after day in a regular day's work without injury, but car horses are constantly temporarily called upon to exert unusual and unreasonable power, which is the reason they are so rapidly destroyed in street car service. It is evident, therefore, that the electric motors must be able, when called upon, to exert the same power that the horses under pressure can be made to perform temporarily, so that the maximum of five horse power in each of the two motors will develop only such force as the requirements of street car service are constantly demanding during their periods of time.

It is not intended in this report to indicate that cable railways for use on steep hills or high grades will be superseded by electric railways, for the latter are limited to such grades as the adhesion of their wheels upon the rails will enable them to surmount, just as in the case of the steam locomotive, so that there is a suitable and proper sphere of usefulness for cable railways in the many places for which they are particularly adapted.

It has been proposed to increase the tractive power of electric cars upon inclines by causing magnetic attraction to be developed between the wheels and the rails, and also by the use of other devices. All these methods present complications which probably will more than outweigh the advantages sought to be attained. In developing the best construction and management of electric cars and railways, careful attention to details, some of which at first sight may appear trivial, should be exercised, in order to obtain the best results, no matter which of the three plans be adopted. It should, however, be said that, in practice at the present time, the running of electric cars requires no more intelligence or skill than the running of horse cars, and also that the electric current, with continuous conduction on lines using a few cars, need not be of such tension as to endanger human life, 500 volts being sufficient. With the storage battery system the tension of the current is so low, 160 volts being sufficient, that no shock whatever could be experienced by a man taking through his body the whole current required to propel the car. This has been repeatedly done, some of the people stating they felt nothing at all, and the others no more than a slight tingling sensation.

The term "storage batteries," so generally in use, is apt to give a wrong impression, no electricity whatever being stored or contained within them, for in charging the batteries a chemical action is forced to take place, and when this chemical action is allowed to reverse itself, electricity is generated thereby. The car motor immediately uses this, and when the motor is stopped, the chemical action and therefore the generation of electricity ceases.

In this report, care has been taken not to refer by name to any patented inventions, or to recommend any particular make of electrical appliances. As to these matters, those proposing to use electricity, whether by overhead or underground conduction or by storage batteries, should of course be careful to select such methods as are the most reliable, efficient and durable, and to deal with parties not only responsible as to the validity of their patents, but capable of doing what they undertake to perform. Any one who peruses the railway journals and notices the number of electric railways now in operation, and the still greater number of those in course of actual construction or projected, has cause for surprise if he has not closely been following the course of events. That electricity, by some of the present methods of its use, or by better ones yet to be invented, will entirely supersede the use of horses and cable traction upon all street railways, excepting under the special conditions for which cable traction is occasionally applicable, is a question that admits of very little doubt.

WM. WHARTON, JR.

The president announced that the paper just read would be printed in full in the Annual Report. He invited discussion of the contents thereof.

MR. R. DUDLEY FRAYSER, of Memphis, inquired as to the figures of the additional weight imposed on a car by the use of the motor.

MR. WHARTON replied that the total of the extra weight was 4200 lbs., viz: storage batteries, 3200 lbs.; for the two motors and their con-

nections with the axes, 800 lbs; for the apparatus to control the current and for other electrical appliances, 200 lbs.

MR. ALBERT G. CLARK, of Cincinnati, inquired as to the amount allowed for deterioration in the item of "operating expenses."

MR. WHARTON explained that the allowance was for the deterioration of the storage batteries, the dynamos and of the car itself; and he had fixed the amount at \$200 per year, as in the case of horse cars. He had endeavored to be accurate but was inclined to think he had been too liberal in this, as in other instances. In other words, he believed that he had over-stated the amount of deterioration. He could not divide it up and tell just how much belonged to the battery how much to the motor and how much to each particular wheel of the whole appliance, but, according to his best judgment, the total was within the amount stated.

MR. WINFIELD SMITH, of Milwaukee, called attention to the difference in the price of coal between that sold in the part of the country from which he came and that sold in Philadelphia. He desired to know the assumed price of coal to be used for the generation of electricity.

MR. WHARTON replied that his own assumption of the cost was based upon the average price of various localities. He suggested that the cost could be estimated by taking the average of prices in Philadelphia, New York and Boston and that, for coal of the character required, this certainly need not exceed \$3 per ton.

MR. ALBERT G. CLARK, of Cincinnati, remarked that, in his investigation on the subject, he had failed to find that any practical underground system had been as yet established. In Montgomery, Ala., fourteen miles of road, on which ten cars are run, are being operated on the over-head system. This plant is worked by two 75 horse power engines, which are capable of being increased to 100 horse power; and there they use, in operating, one and one-half tons of coal per day. In Lima, Ohio, five cars are being operated with the expenditure of seven barrels of oil per day, at 39 cents per barrel. According to the information given him, oil at 68½ cents per barrel was equivalent to coal at about \$2.50 per ton. In Mansfield, Ohio, a road is being operated by electricity. Both in Mansfield and Montgomery, there is an eight per cent. grade.

MR. MOSS, of Sandusky, Ohio, inquired as to Mr. Wharton's preference for two motors of five horse power each, instead of one of ten horse power.

MR. WHARTON replied that, in his opinion, the two motors of less power afforded better opportunities of combination in adjusting the current and in manipulating its strength. On the other hand, double labor was involved in keeping two machines in order and the liability to break down was also doubled. As an offset to that, however, there was the counter consideration that, if one machine broke down, the other could be availed of to keep the road in operation. With two motors in use, each can be applied to an axle of the car and thus all four of the wheels be made driving wheels. With but one motor, only the two wheels on the same axle can be made driving wheels. Certain advantages are to be gained on either plan. The question is one which can only be answered by careful study and actual experience.

MR. MOSS, of Sandusky, said he had heard with surprise the statement of the report that the batteries had been stored in four hours, because only on the previous day, in New York City, the statement had been made in his hearing that thirteen hours had been consumed in the storing of what he understood to fifteen horse power batteries.

MR. WHARTON answered by reiterating the assertion made in his paper that he had not consumed more than four hours in storing his batteries. He again declared that this period was abundantly ample.

MR. CALVIN A. RICHARDS, of Boston, commented upon the persistency with which the author of the report had been interrogated upon its details and deprecated what he regarded as a carping criticism of a paper which, in his judgment, was the most exhaustive on the subject which could have been rendered. He contended that the mere fact of the utilization of that unknown power, electricity, for purposes of transportation was something which was entitled to be received with joyful acclamations by all present. It was perhaps well known in the convention that he (Mr. Richards) had been one of the most earnest, as he was one of the earliest, advocates of the system under consideration. He was delighted and gratified with what Mr. Wharton had accomplished and, in the light of the fact that much yet remained to be done, it seemed proper for the convention to pause at this point and take an observation upon the point they had reached in this great field. For one, he did not propose to inquire critically into the whys or the wherefores of it; it was sufficient for him to know that the essayist had given a demonstration of the practicability of propelling street cars by this new medium, at a cost much less than that of animal power. There was in this, he thought, sufficient cause for jubilation and mutual congratulation. He desired simply to make one suggestion, and that was that Mr. Wharton should give an exhibition of his goods; in other words, should enable the association to make a personal examination of the running of a car by electricity.

[The secretary (Mr. Richardson) here read a letter, dated Oct. 19th, which he had received from the Electric Car Company of America, and from Wm. Wharton, Jr., and Company, incorporated, inviting the members to visit the works of the two companies.]

MR. MOSES HUMPHREY, of Concord, N. H., said that, after an inspection which he made two years ago of the steam motors in use on the Brooklyn road, he went home and ordered two steam motors for the Concord railroad. These had been since, and were now running. They had proven highly successful and had more than doubled the receipts of the road. If now there was something better to be had, he wanted to have it.

[A motion by Mr. Littell, of Louisville, as amended by Mr. Hood, of Camden, that the invitation just read be accepted, and that a vote of

thanks be tendered to Mr. Wharton for his able and exhaustive report, was adopted without dissent.]

MR. CHAS. CLEMINSHAW, of Troy, N. Y., explained that the inquiries propounded to Mr. Wharton had not been inspired in any spirit of criticism, as had been intimated by Mr. Richards, but to acquire information.

MR. WHARTON, in reply to Mr. McCreery, of Pittsburgh, stated that arrangements would be made by which the members of the convention would be enabled to examine the motor car and its plant on this (Wednesday) evening and also on the following evening. He proposed to show them a car which could surmount a six per cent. grade. He had himself traveled on a railroad in Scranton, Pa., on which a grade of 7¼ feet to the hundred was surmounted with perfect ease; and he had been told of a railroad in Pittsburgh on which the motor did ascend a grade of 12½ feet to the hundred.

[The Secretary here read letters extending to the convention the hospitalities of the following institutions: Girard College, Union League, A. Whitney & Son's Car Wheel Works, Masonic Temple, and Baldwin Locomotive Works. An invitation from the Board of Passenger Railway Presidents of Philadelphia to join them in a banquet at the Union League building on Thursday evening, at six o'clock, was also read. The invitations were accepted with thanks and acclamation.]

MR. WHARTON, informally replying to an inquiry by Mr. Winfield Smith, of Milwaukee, as to the merits of the steam motor in comparison with electricity, stated that there are many localities in which the use of steam on the streets is prohibited, and that the cost of steam when used in portable engines is relatively greater than that of electricity as applied to portable engines.

At 1:20 p.m. an adjournment was taken until 3 o'clock.

Upon the re-assembling of the convention in the afternoon, on motion of Mr. Powers, of Boston, the pending order of business was informally deferred to permit Mr. F. J. Sprague, of the Sprague Electric Railway and Motor Company, to submit some remarks suggested by the discussion on "Electricity as a Motive Power."

MR. SPRAGUE said that, of the three general systems applicable to street railways, viz.: the overhead wire, the conduit, and the storage battery, the first is the cheapest and the one most frequently in operation. The conduit system would doubtless be used, in some cases, where the number of cars in operation is large and the return proportionate to the investment. The storage battery system will be used where there are only a few cars and these are running under long headways. It requires a liberal outlay of capital because it must stand the same strain and conditions of weather and traffic which a cable conduit must stand, and, in addition, must provide ample protection for the conductors on which the operation of the whole system depends. Such an investment can not be made where cars are run at long intervals, because the traffic receipts would not pay a sufficiently remunerative dividend. The storage battery system offers the advantage over the others of perfect independence of action, but it has this disadvantage, that the capacity of the battery is limited, while the weight of it is objectionable and its depreciation not easily ascertained. Storage battery companies are in the habit of guaranteeing their batteries for two years upon the condition that not more than a certain capacity is required of them. It is quite possible to develop, with a good battery of not over 3,500 pounds in weight, fifteen horse power with a net efficiency of about 73 or 80 per cent.

The question of traction, upon which objection has been made by some street railway men, seems to have been met. We have had, said Mr. Sprague, a car, driven with only one pair of wheels, surmount a six per cent. grade. This may be considered to have been done under exceptional conditions of track, but it was done on a very sharp curve. If both axles are driven independently—the one not being dependent on the other—there is no question that a six per cent. grade can, under all circumstances, be taken.

In the adoption of any system or method of operating cars by electricity, the question of the number of cars operated is a most serious one. If operating one or two cars over five or six miles, it were better to dispense with electricity. When operating three or four cars, the question of headway is an important one, unless the power is derived from some existing station, or under exceedingly economical conditions. A certain number of cars, under given conditions of station operation, must be operated under any of the systems before any economy, as compared with the horse traffic, can be attained. The greater the number of cars, of course the more apparent that economy will be.

#### STREET RAILWAY MUTUAL FIRE INSURANCE.

The next business was the reading of a paper on Street Railway Mutual Fire insurance, prepared by Mr. John Maguire, of Mobile, Ala. Secretary Richardson explained that Mr. Maguire had been for many years personally interested in the insurance business aside from his interest in street railways. The paper is as follows:

#### Report of Committee on Street R. R. Mutual Insurance.

To the American Street R. R. Association:

GENTLEMEN—We have the honor to make the following report on the subject of Street R. R. Mutual Fire Insurance. The subject is an important one, and I fear we have done it scant justice.

The order of the hour seems to be combinations of in-

dividuals and corporations with mutual interests; why not the street railroads combine and form an incorporation for the protection of their extensive properties from fire?

The fire insurance companies of the United States, and the agents of foreign insurance companies in this country, have formed a combination which they term Tariff Associations, and have subdivided this extensive country into territories; two of these sub-divisions are under our immediate notice, to-wit, the Northwestern, with headquarter at Chicago, and the Southeastern Tariff Association, with headquarters at Atlanta, Ga.

These associations have state and local organizations, the latter of which are called "compacts." Their province is to enforce the rules and rates of the territorial organizations. They adjust the rates of insurance and discipline their members. We have only to deal with their action in regard to street railroad property, on which they have increased the rates from 25 to 50 per cent. additional.

The latter figure is the experience at this point, when you complain of the excessive rate you are informed that is the rate fixed, and "If you no likee, you no takee." The more courteous will argue and say, that of late years the insurance capital of the country has not been profitable, and they were obliged to advance the rate of insurance or retire from the insurance business.

Let us criticise the methods of doing insurance agency business and see the necessities of the charges added to pay for their method of doing business, and compare it with the Mutual Insurance Companies of New England, and let us profit by the comparison.

In the first place, to do a general insurance agency business you encounter the genial and clever local agent, whose first and last motto is, get insurance premiums and swell the commission account, upon which he lives and thrives. Upon the volume of business he secures he is never allowed less than 15 per cent., and in some instances as much as 20 per cent.

Another plan frequently adopted is for a company to have a state, or several states general agency, and such agent is compensated at the rate of 20 to 25 per cent. of the premium receipts of his territory, he paying the local agent his share of the commissions.

Now the necessity exists to supervise this business, and a general agent and adjuster is appointed, whose duty it is to inspect all the business of the several territories or subdivisions over which he is appointed.

This is a salaried position, and varies with the volume of business done, with expenses paid. It is approximately 3 per cent. of the premium receipts.

Now we get near to the home office; but before getting to the officers of the corporation you reach the very important official, "superintendent of agencies," with his clerical corps. This office will absorb two or three per cent. of the premium receipts to run it.

Now we are at headquarters, and the officers of the corporation have to be paid. Let us now see what all this amounts to. The statistics for the year ending Dec. 31st, 1886, exhibits the startling fact that the expense account of some ten of the largest companies in the United States approximate 40 per cent. of the premium receipts, the smaller companies a larger per cent.

The experience of these insurance companies for the year 1886 is

Premiums Receipts .....	102,000,000
Losses .....	53,000,000
	Or, 52 <sup>1</sup> / <sub>10</sub> per cent.

The experience of the State of New York, where the largest values exist, shows the losses approximate fifty-one per cent.

Now let us look for an explanation—we have it—the statistics made by the insurance journals gives the item of incendiary fires, for the year 1886, in the United States, at 26 per cent.

You hear insurance experts talk of the "moral hazard." Others discuss it, and call it the "friction of a large insurance policy upon a small stock of goods."

Now in making up the insurance rates this per cent. is



added to the insurance rate, then add 40 per cent. for expense account, and you have fully sixty per cent., which, if deducted, leaves you the absolute cost of the insurance, provided you eliminate the two items mentioned.

The incendiary hazard is exceedingly small in connection with street railroads, none internal, where could profit arise by the destruction of the only means a company has to do business, which would, if destroyed, take months to replace, and in the meantime no revenue and an expense account of organization going on.

It is true street railroad property does sometimes burn; so do fire-proof warehouses. No one expects to get insurance on street railroad property as low as many of the first-class risks, which are taken for about one quarter of one per cent., or, say, one-half of one per cent. for three years. On the other hand, it is not fair to class street railroad stables and car sheds as ordinary livery stables, which is the classification of the insurance rating committees.

Now let us examine the experience of the New England mutual insurance companies, organized to protect the mill property of that thriving section. Before the organization of these mutual insurance companies, the rates on mill property ranged from one and one-half per cent. for a first-class risk to three per cent. for an ordinary risk, or fully two per cent. as an average rate. Now things have changed, and the said mills are charged only the actual cost of the insurance, and have returned them annually about one-half of the premiums charged them, which approximate eight-tenths of one per cent., and one-half returned to them, on average years. One year's basis is not a fair one to quote, so let us take five years, from 1882 to 1887, and the following statistics of six of the largest mutual companies in the State of Massachusetts:

Their insurance premiums, collected for the average of this period, were each year approximately.....	\$1,520,000
Losses paid, average for each year were.....	370,000
Returned to policy holders each year.....	1,002,000
Expense account of doing the business per annum.....	115,000

Which approximates eight per cent. of the premium receipts.

Prior to the establishment of mutual companies, the stock companies claimed that the rates were not profitable to them, because of the nature of the hazard.

The mills paid but little attention to the improvement of their risks, fires were of frequent occurrence, and large losses were entailed.

The practical mill man and the expert insurance inspector put their heads together, and for each suggested improvement a lower rate of insurance was fixed, so that now they are first-class risks, as the past five years' experience shows that four-tenths of one per cent is abundant rate to cover losses, the higher rate being charged to establish a reserve fund in the event of extraordinary heavy losses occurring in any one year.

What has been done by the mill owners can be done by the street railroad companies associated together for mutual fire insurance protection.

Why corporations whose capital invested equals the combined fire insurance capital pay a tribute of upwards of forty per cent. for expense of management of insurance companies, when it can be done by themselves for less than one quarter of the amount, and but a fractional portion of the incendiary experience needs be entertained.

Then let us dispense with the middleman and do our business at absolute cost. It may be said, "How can so small a capitalization carry so much risk?" True, to do so would be like unto gambling.

If any risk is offered which is greater in amount than it is wisdom to carry, you have large insurance companies which will contract to take the surplus or excessive lines of insurance, for which they will contract to take at the rate, and give twenty-five to thirty per cent. for the business, if the main office is dealt with, as they would be exempt from the payment of commissions to their agents.

This direct business is done every day. The main offices of the several foreign agencies take large lines of insurance upon the steam railroads of the country, and the

rate is fixed by private arrangement regardless of local agents.

It is largely upon this character of business and re-insurance of local companies that the enormous premiums of such agencies are aggregated, one of which has an annual income in the United States of \$1,000,000, far greater than any American insurance corporation.

The value of a rigid inspection of fire risks can hardly be estimated, it is invaluable. An expert will detect a hazard that will be passed by hourly and no attention paid to it.

Improve the fire risk and the rate per cent. can be materially reduced. No reason why Street Rail Road Insurance can not be reduced one-half, to say naught of the return dividend made by mutual companies.

The rate under the present system of insurance is almost prohibitory, and many corporations are not one-half insured, many others have no insurance, preferring to carry the risk rather than to make so large an expenditure of money. In many instances said insurance will be equal to an interest on the capital involved.

Now, how to organize a Mutual Street Rail Road Insurance Company, thus—let each company of this association deposit an amount equal to one year's insurance premium as a guarantee capital, which will amount to fully the suggested capital of \$200,000. This money can be invested in undoubted securities which will pay say four per cent. interest which can be paid to the companies making the deposit as so much dividend, and if only a few of the companies enter into the capitalization a greater rate of interest can be paid to the capital furnished, which might be considered a hazard, and fully entitled to remuneration, allow all Street Rail Road Companies in the association to participate in the Mutual Insurance benefit; aggregate the insurance premiums for say three years so as to establish a surplus or guarantee fund; at the end of each year issue a scrip dividend bearing annual interest payable at no fixed date, but which should be paid within three years unless extraordinary losses occur.

This method allows an accumulation of a surplus capital and contingent fund from which dividends can be made with some regularity, even if more than ordinary loss occurs. This the company would make haste slowly.

Organize a Mutual Insurance for Street Rail Road property, and proceed so that the most timid can appreciate the benefit, and take but little risk. Do this until the organization is placed on a firm foundation.

Re-insure all but small amounts to be carried by the company, and profit by the re-insurance of not less than 25 per cent. This amount you can not possibly procure without organization.

As previously stated rigid inspection by a qualified person whose direction must be followed to secure a reduced rate.

Insurance companies hold this inspection business as a necessary incident to their success. Now they who have a hundred variety of risks to inspect and can not afford to employ a special expert for each character of business they regard their inspection as superficial, as compared to the inspection by a special expert in the business.

What has been done by others can be done by us, more particularly as we have the benefit of their experience. Organize, organize, and do so without further delay.

No other interest so large as the street rail road would tamely submit to the arbitrary rates charged by the insurance corporations, which rate is necessitated by their method of doing business.

Your committee will be repaid for their research if this report will get you to think and cause you to act on this important question. Respectfully submitted,

JOHN MAGUIRE,

Chairman of Committee on Street R.R. Mutual Insurance.  
MOBILE, ALA., Oct. 15, 1887.

MR. HASBROUCK, of New York City, remarked that the locality from which he came was alive to the importance of the question; that steps had been taken to organize a Mutual Insurance Company, but these had not yet assumed tangible form. In regard to the extra haz-

ardous nature of the risks, as represented by the insurance agents, he thought that his hearers could fairly estimate what those representations amounted to. Railway men believed that the extra protection of private watchmen, police, the collection of hand grenades, etc., ought to lessen the amount of risk; but the agents were accustomed to tartly respond that they had given their tariff rates, and it therefore remained simply to accept or reject those rates. The Broadway and Seventh Avenue Company were now putting in, at their stables, Harkness' Sprinkler. The Company's insurance amounts to about \$500,000. They had been promised a reduction of from 33½ to 50 per cent., if they would run that apparatus through their buildings. They expected by the first of November, when a large amount of their policies expired, to avail themselves of the offer of the insurance companies by having this apparatus completed. The apparatus is a system of piping placed on each floor of the building, with, at intervals of 100 feet, a valve or outlet which is closed with soft metal. A temperature of 120 degrees melts the metal and then the fluid in the pipes is released and a copious discharge is made, which extinguishes a blaze which may be within reach. The fluid is non-freezable. At an expense of about \$25,000, this apparatus could be operated on every floor of the property.

MR. R. DUDLEY FRAYSER, of Memphis, asked whether any practical test had been made of the apparatus.

MR. HASBROUCK replied that its utility had been demonstrated; that he did not know Mr. Harkness, but that he knew that the sprinkler had been adopted after a thorough investigation and that it was guaranteed by the insurance companies and was in use by numerous manufacturing establishments in New York.

MR. W. W. PATRICK, of Pittsburgh, inquired for information as to the rate of insurance paid in the several cities; the rate in Pittsburgh being 1¼.

MR. HASBROUCK said that the rate in New York State was 1½. And Mr. Lewis, of Brooklyn, stated that an insurance had been effected to the amount of about \$1,000,000, on August 1st, by the company he represented, at an average of one per cent.

MR. WALL remarked that one and a half and two per cent. was charged in the West.

MR. HASBROUCK explained that the low rate obtained by Mr. Lewis was exceptional, as it was secured at a time when the bottom had fallen out of what was called "the insurance coalition."

MR. CHARLES ATWELL, of Pittsburgh, expressed the opinion that the only data on which an intelligent judgment could be formed with respect to this matter of insurance was that which related not to the character of insurance generally or the experience of insurance companies, but that which would enable a comparison to be made between the amount of premiums which had been paid to street railway companies upon street railway property for a term of years and the amount of losses paid to them. It could be determined from this whether it would be a wise thing for railway owners to insure their own property or to trust to the insurance companies generally.

The Secretary replied by quoting the statistics in the Report of the Fourth Annual Meeting, covering a period of thirty years.

MR. THOMAS H. JOHNSON, of Salem, Mass., said he spoke both as an insurance man and one interested in horse railroads when he advised the use by his associates of the best appliances for protection against fire. If these were availed of, the insurance companies would insure car stables more cheaply than the owners of the stables could insure their own property. The reason for this was that the insurance companies allow a considerable reduction where the improved appliances are in use.

MR. CALVIN A. RICHARDS, of Boston, spoke of the arbitrary raising of their rates by the insurance companies upon stable and other property in which fires occasionally occurred. He also complained that they no longer issued what had been known as "blanket insurances," in which several thousand horses or cars were insured in bulk; but they now required a specific rate with reference to the location of horses or cars. He intimated that the insurance men were able to dictate terms to their customers because of the advantages which they enjoyed in unity of action. He suggested that the city railway interest could carry on an insurance business for its own protection at one-half or one-fourth of the cost under the present system of paying rates to insurance companies. By avoiding the building of marble palaces for offices, as had been done by the insurance companies, and by retrenching expenditures such as high salaries for officers and the like, the railway interest could certainly insure at a more economical rate than the one at which it was now paying.

MR. SECRETARY RICHARDSON detailed several instances to show that the treatment of members of the American Street Railway Association by insurance companies had been most exasperating. In one instance, that of The Atlantic Avenue Railroad Company of Brooklyn, the company had for twenty years paid an insurance yearly, aggregating well on to \$100,000. When they were subjected to a small loss of \$6,000 or \$7,000 by a fire, their president had been exasperated by the treatment he received from, and the annoyance to which he was subjected by, the insurance companies. Mr. Richardson went on to explain that the American Street Railway Mutual Fire Insurance Company, though duly incorporated, had not fulfilled expectations for the reason mainly that it had attempted to do what might be regarded as riding two horses at once, by combining the idea of a business on a cash capital with that of a mutual insurance business. If the capital of the company had been limited to \$200,000, a working organization would have been promptly effected, and the company would have started low and worked up. In undertaking to cover the United States and Canada, the company had attempted, in the language of the Kentuckian, to "bite off more than he could chew."

MR. WOODWORTH, of Rochester, N. Y., moved the appointment of

a committee of five to further investigate the matter of a Street Railway Mutual Fire Insurance Company with power to take such action as they might deem best.

MR. C. A. RICHARDS inquired whether the proposition contemplated the creation of a company.

MR. WOODWORTH explained that such was not his intentions, as the only purpose of his motion was to give the subject some definite shape.

MR. C. A. RICHARDS suggested a modification of the motion (which was accepted by Mr. Woodworth), requiring the committee to report to the association before taking any action.

The motion as modified was adopted without objection.

#### MOTORS OTHER THAN CABLE OR ELECTRIC.

The report on this subject, prepared by Mr. D. Atwood, Milwaukee, Wis., was read by the Secretary. It was as follows:

*Mr. President and Gentlemen of the Association:*

I have hesitated to make a report to this body, as required by you, and it is with one regret that I do so, on mechanical motors for street cars, other than electrical, the text which has been selected for me. Probably no other question that will come before this meeting is of more interest than the problem of what is best, if anything, in the line of mechanical powers to substitute for horses. The immense development of street railway interests during the last few years seems by common consent to call for some change from horse power to that which will offer the public more rapid transit, and at a cost which will justify the companies in making the change. Under some circumstances I believe it is now settled that the cable meets the requirements. To determine in my own mind whether any other appliance has reached such a degree of perfection as even to warrant a practical test, I would have had to spend more time than it would have been in my power to have given the matter. Hence I say, I regret that I was selected to make a report on this subject. It is of sufficient gravity to warrant the most exhaustive personal examination of the different systems offered, and I am compelled to say to you that I have not been able to do this in any one case, much less in all of them.

Perhaps my long experience in connection with street railway construction and management may entitle my views, from the information I have, to some consideration, and such as they are I briefly give you. And first, a brief history of the actual result of street experiments with different motors as given by that veteran street railroader, Mr. John Stephenson, of New York, will, I think, be considered in point. Mr. Stephenson was interested in the first experiments in this line which were made between 1832 and 1834, in New York. The New York and Harlem Railroad (Fourth avenue) having been in operation for two years with horses on the lower end of its road, and finding that they could not successfully compete with omnibus time, then on the Third avenue, commenced the era of steam motors made by Wm. T. James, of New York City, and such efforts with modifications of motors were continued about four years.

In 1860, the Second Avenue Railroad Co. commenced operating the upper end of its road (three and one-half miles) with cars having the steam motor in the front end of the car, in an apartment separate from the passengers, which in about twelve months was changed to the system of independent motors, which were increased to heavy engines and steam road cars (eight wheel cars). This era of steam occupied about six years, and was then abandoned.

The Market-street road of Philadelphia adopted steam motors in 1876, continuing them about one year. Brooklyn having many roads reaching to the sea shore, very largely adopted steam motors in 1877, but all, or nearly all, were abandoned within five years. Various efforts were made to use compressed air engines; also water heated to a high degree, giving off vapor under pressure; also springs compressed—electrical engines and gas engines, with all of which we have been familiar, but failure only has resulted.

Coming to 1883, England has been for fourteen years vigorously pushing such experiments regardless of cost, but with no better results, and the French efforts may be summed up by the following quotation from a recent report: "After an experiment of five years and exhaustive tests of twenty-one different systems, the Paris Tramway Co. has abandoned the use of steam, and reverted to horses as a cheaper and in all respects more satisfactory motive power. Scarcely a week has passed without some accident on the steam lines which proved costly to the company and led to complaints from the public. At last the authorities forbade the further use of steam, and the railroad company was perfectly ready to acquiesce."

Mr. Stephenson sums up the following opinion: "To the above may be added that an ordinary tramway plant is not sufficient for such use, but is soon destroyed, because of the weight of motors (from 12,000 to 20,000 pounds) in addition to the wriggling motion of the engines. We regard the question as fairly settled, that no mechanical motor is yet in sight to take the place of animal power in propelling street cars. To this conclusion may be excepted in part the cable system, which has only developed superiority on grades, where animal power could not be used. The heavy first cost of the cable system, with its complicated machinery, subject to accident, causing delays, wide-spread inconveniences and loss, are serious drawbacks, for which remedy has not yet been found."

The more prominent candidates for favor that differ materially from those mentioned by Mr. Stephenson may be said to be the Conolly motor, which relies upon naphtha for power; the system of California, which proposes to use compressed air; the Pole street car, which, using any form of power, relies for success upon a very ingenious device consisting of two legs, so-called, that may be applied to the ground when



necessary to push the car over grades, or move it when the ground is slippery. As described by the inventor the automatic foot action in this motor is a perfect step action, made so that there is a perfect rise and fall accurately placed on the ground, there held down, and the motor forced forward, giving, as the inventor says, a step like that of the front legs of a horse. Then the soda motor, and the ammonia motor, I think, about complete the list.

Beyond the claims made by the owners of these different systems I can report nothing. That all forms of power proposed will drive a car under certain circumstances and conditions I have no doubt. That this can be done practically, so as to be economical, there has been no demonstration made that warrants my endorsement. All independent motors, in my judgment, are governed by the same laws that affect a steam locomotive; where the conditions thus settled to be essential are met by any other form of power that is to be used to drive a car, then I would think that the car could be moved successfully. Where these conditions in the strength and character of the track, or in the weight of the motor, are lost sight of, I would expect any form of independent motor to fail. Again, if it is conceded that a motor of proper weight, and a track of sufficient strength, can be devised with a power to drive the motor that is practical and all right every way, still it is not clear in my mind that such a machine can be successfully operated and controlled in the crowded streets of a large city, much less that the rails in the street can at all times of the year, winter and summer, be kept in a condition at any reasonable expense, where a traction engine would be reliable. In taking this position I do not mean to offer any special criticism on any special kind of motor; I would like to have done this if I could have done so fairly, with that kind of close knowledge of each that alone would justify it. But generally, I must say, none of them impress me even from the claims made, as likely to cover the ground I think essential.

I have stated my objections in the main, and to me these are serious enough to require any independent motor, which is offered, to be put in actual, successful, every-day service for a year or more before the owners would have a right to expect the street railway interests to indorse it.

From this it will hardly be necessary for me to add that, having been accustomed to seeing a street car pulled, positively, by a pair of horses through the crowded streets, up hills and around curves, in the mud, and through the snow storms, under conditions where a steam railroad could not be operated at all, that I believe the mechanical power that takes the place of horses must also be able to do the same thing. I believe it fair to state, and I think it will be the sense of this convention, that up to this date, to all intents and purposes, the issue is narrowed down between the horses and cable. If the first cost of the cable system could be reduced to a price within the reach of the business done by the ordinary metropolitan roads, and the cost of maintenance of such a plant could be reduced to the ordinary and usual depreciation in machinery, say not to exceed 10 per cent. I am convinced there would be but little left to look for in the light of present experience.

I have been watching for over a year past the experiments being made by some parties with what is called the Rasmussen cable system in Chicago. It ought to be named the McNeill system, all the work and designs for the road having been made by Mr. H. W. McNeill. As a result of these experiments this gentleman is now constructing between four and five miles of road on Market street, Newark, N. J., which will be in operation this winter. I believe it will succeed. I have personally no doubt about it; and if it does, the result will be a mechanical power having all the advantages of the California system, with practically none of its drawbacks, either in construction or operation, and at a first cost of say one-third or less. Yours respectfully,

D. ARWOOD.

MR. CALVIN A. RICHARDS, Boston, requested the secretary (Mr. Wm. J. Richardson) to read his paper, as follows, on ROADWAY CONSTRUCTION.

#### *The American Street Railway Association:*

GENTLEMEN—There are to-day two distinct types of street railroad construction—the stringer and the girder. Without wasting time in any definition of the differences which are well known to the members of this association, we will slightly outline the history of the two types, and then deal with their practical details.

We have, in this country, been inclined to regard old England as very conservative, and one who left it to younger blood to "originate," and who only followed the march of improvement when others led. The history of street railroad construction somewhat negatives this. We will show that England was the originator of both the stringer and the girder system of street railroads, but it will be also our task to show that to this country is due the progressive development of both systems. Over two centuries ago the original tramway was developed and brought into use in the mineral districts of England. It was used principally for the transportation of coal; and we find that the great inducement to its use was the defective condition of the ordinary roads. The early tramways consisted of scantlings of good, sound oak, laid upon cross ties, and pinned with oak tree nails. It is a matter of interest to note that the cross ties were laid tolerably close together—about every two feet. From this primitive construction, the evolution of the perfect system of to-day as been as gradual and regular as that of a man from Darwin's "Ape."

First, we find that the rapid wear of the timber called for the use of a rail. But it was a rail of wood. Clarke, in his valuable treatise on "Tramways," tells us that the rapid abrasion of the timber led to the placing of a wearing rail on top of the stringer. He says this second rail became a wearing piece, and was made of hard wood—beech or sycamore. As a step forward, it became a common practice to nail down bars of wrought iron, generally two inches wide by half an inch in thick, "on the surface of the ascending inclines."

Now, gentlemen, note—We have the first lesson in one of the essentials of good construction, viz. the need of rigidity and true surface. Clarke continues, "But the iron bars not being stiff, were considerably bent when the trucks were loaded, and the resistance, according to Mr. Wood (an English authority) was reduced."

#### *Below that of a Well Constructed Wooden Railway."*

We shall see, as we proceed, how "history repeats itself," and how this experience has been borne out in modern America—practically England thus having originated the stringer system, it remained for America to develop and improve. It is well to note that the rapid introduction and development of tramways in this country was largely brought about by the same considerations which prompted the early use of the coal tramways in England, viz., defective roads and consequent difficulty of rapid transportation. We think this a point to be remembered, as we purpose showing that, in dealing with the subject of road-bed construction, the condition of the streets through which we build is a factor that must largely influence the construction.

In New York, in 1832, the New York & Harlem constructed its road. The flat strip of iron was improved upon by a substantially heavy rail. In other respects the construction was not much varied. This line, living through some early vicissitudes, was the forerunner of others, and in but a few years the American system of tramways had increased to magnificent proportions. In details of construction there is little to note. We find an infinite variety in the shape of the rails, but so far as the construction of the road-bed on the stringer system is concerned—none. During this rapid development here we find a more gradual and conservative growth in England, and, as we purpose touching upon the various types of rails and their causes, we can best do so by dealing with English progress contemporaneously with our own. The early rails used in this country were like those now used in England, grooved rails. That is to say, flat on the upper surface, provided with a groove for the passage of the wheel flanges. In 1856 the rail used in Boston was a slight departure, tending more to our rail of to-day. The groove was tapered out to the edge of the tram, and shortly afterward the outer edge of this taper was entirely lowered in the city of Philadelphia, thus developing in its entirety the ordinary side bearing tram rail of to-day, still largely known as the Philadelphia tram rail. Of late years this type of rail has been remodeled by moving the head from one side to the center, giving rise to what is known as the center bearing rail. In the meantime the flat rail, with a small, central groove, has been persistently adhered to in England, and largely, also, on the continent.

It behooves us to ask why this difference? It is the more important to dwell on this point now, as there is a growing tendency on the part of the authorities of the large cities to demand the use in this country of the English groove rail. Looking into the English tramway we find a rail neatly bedded in the road surface, nothing obstructive. A passing carriage or wagon drives at random over the English track, and at any angle. There is no denying the fact that the system is a perfect and non-obstructive one. Nor is it surprising when our legislators, who are over there (generally, by the by, those who own their own carriages), see this perfect system, that they want it here. But we, as practical street railway men, know, by sad experience, that there are two sides to such questions as this, and that it behooves us to look always at "the other" side before we leap. Stop and think a minute. We have tried this rail, and we did not at once throw it away. We departed from it gradually; first, by a slight taper; we then parted from it still further, and, finally, left it entirely. When progress tends slowly and gradually in a given direction, does it not prove that it is not hasty or ill-advised? Does it not carry on the face of it the certainty that a cause exists for its continuing in the path in which it is treading?

To the bystander a street is a street, and a street railroad is a street railroad. To the engineer, the contractor and the street railroad man, they are both something more. A street to them is one of a hundred different types of construction. At best, these hundred types can be narrowed down to but three classes—good, bad and indifferent. In this country, generally bad, and, gentlemen, what the street is, that must the street railroad largely be. Given a bad and poorly kept up street, and, do what you will, you can not, in that poorly kept-up street, put any rail or build any track that will be entirely non-obstructive. Even in the best of our street constructions, we to-day fall far short of the English and Continental road bed. We use granite paving, it is true, but such is our rapid growth, we lay it upon made ground that, perhaps, a few years back, was a marsh, and we replace, almost between winter and summer, the croak of the frog by the jingle of the street-car bell. Abroad they lay their granite on a roadbed that has been settled by the weight of centuries, built, perhaps, by the Romans, and they can well afford to construct, regardless of cost, certain that when once laid, they are immovable till worn out. And when the municipal authorities do their part, and furnish us such streets as this, we may find that it is possible to use a grooved rail like that used here; but until then it would seem folly to throw away the experience of years; and any effort to force the use of the narrow groove rail will but react upon itself. Two things are needed for an absolutely non-obstructive tramway:

First, A track well built, with non-obstructive rail.

Second, And most important, a uniform and well constructed road-bed that will keep level with this track.

Given the perfect roadbed, and it will soon be found that the street railway man will, in his own interest, put in the perfect rail.

We do not apologize for taking up the time of the convention with this subject, for we believe it to be one of greatest importance, and worthy of due and careful consideration.

In this country, therefore, the rail has really been the product of the street.

So much for the stringer system.

(Continued on page 229.)

# The Street Railway Gazette.

	Annual Subscription (Including Postage).	Per Copy.
United States, Canada	\$2.00.	20c.
Great Britain, Ireland, India, Australia	10s.	11d.
Germany	9mk. 75 pf.	89pf.
France, Belgium, Switzerland	11fr. 95c.	Fr 1.10.
Spain	11ps. 95c.	Ps 1.10.
Austria, Holland	5fl. 74c.	53c.
Italy	12 lire.	1½ lira.
Venezuela	12 bolivars.	1½ bok.
Mexico	\$2.96.	30c.

*Ann. Subs. in Argentine Republic, 2½ peso; Brazil, 4 milreals; Turkey, 54 plasters*

Registered Cable Address=TRAM, CHICAGO.

## PUBLISHERS:

THE WRIGHT-MONROE COMPANY.

P. G. Monroe,	President.
E. V. Cavell,	Secretary.
S. L. K. Monroe,	Treasurer.

## GENERAL OFFICES:

CHICAGO, - - - NEW YORK, - - - BOSTON.

### CHICAGO:

9 LAKESIDE BUILDING.

William Hughes,	Editor.
Edward J. Lawless,	Associate Editor.

### NEW YORK:

181 BROADWAY.

Henry C. Lockwood,	Resident Editor and Manager.
--------------------	------------------------------

### BOSTON:

19 TREMONT ROW.

T. P. Pemberton,	Resident Editor and Manager.
------------------	------------------------------

## EUROPEAN OFFICE:

LONDON: W. S. G. Baker, Jr., (care Brown, Shipley & Co.), Res. Mgr.

## BRANCH OFFICES:

ATLANTA, Ga.: Chamber of Commerce Bldg., Wm. Minnigerode, Mgr.  
SAN FRANCISCO, Cal.; 1222 Bush St.—G. W. Fairchild, Manager.

## CANADIAN AGENCY:

TORONTO: 53 Magill Street,—Thomas Henry, Manager.

THE PHILADELPHIA CONVENTION is over. We cheerfully devote our whole space this month to give a full and accurate report thereof. Beside the prominent men who took leading parts in the proceedings, we may well mention the names of some of those who contributed very much to the success of the Sixth Annual, in various ways, such as Mr. Chas. Clemenishaw, president of the Troy and Lausingsburgh RR. Co., Mr. H. H. Littell, Louisville, Mr. Wm. Richardson and Mr. D. F. Lewis of Brooklyn, Mr. H. M. Watson, Buffalo, Mr. Jas. A. Collins, Cincinnati, and Dr. A. Everett, of Cleveland. We also noticed Mr. H. A. Everett, Dr. R. L. Robb, Dr. L. H. Adler, Mr. R. D. Frayser, Messrs. C. Hathaway (father and son), Mr. S. Robison, Mr. Keeler, Mr. Samuels, together with Messrs. Horace A. Keefer, H. E. Evans, W. N. Lewis, D. F. Longstreet, John N. Reynolds, General Stiles, A. H. Henderson, W. H. Reid, J. H. Small, A. Johnson, John E. Bailey, W. W. Bean, W. W. Anderson, C. B. Clegg, etc.

ELECTRIC RAILWAYS, as may be seen from our report, was the most animated subject discussed at the Convention. Electricians were eager for the fray, and the delegates were anxious to hear what each one had to say. Questions poured in by the score; and they were readily answered, especially by Mr. Van Depoele, who met each enquiry most clearly, and left the platform amid a torrent of acclamations. Mr. Wm. Wharton was the best on the statement in chief (if we may use the expression), but in answering cross and unexpected questions he was not the best. Mr. Wharton, however, did more than any one in showing what electricity could do in the way of propelling a street car, and ran an electric car filled with delegates over the City of Brotherly Love.

CABLE railway companies are preparing for the frosty season. We hear of one cable line, constructed this year, where due allowance has been made for the expansion and contraction of the ironwork itself, caused by heat and cold, but the pressure on the rails caused by the same agencies seems to have been entirely forgotten; and there may be the same troubles as overwhelmed a similiary built road last winter, where the frost spread apart the paving stones lying between the rails until the grip slot closed up and firmly gripped the grip itself.

PROFESSOR RECKENZAUN claims to have fully demonstrated that the motive power for propelling a full-sized street car, fifteen hours a day, can by storage battery be supplied for \$1.75, including all expenses of engine and dynamo, so that the total cost does not exceed one-half that of the cheapest horse traction. The cost as compared with the cable system has been discussed, and it is shown that while not more than 20 per cent. of the power developed by the engine is utilized in propelling cars by the cable, at least 40 per cent. is utilized by the storage battery; while the cost and inconvenience of tearing up streets is avoided.

U. S. MAIL service on street cars, initiated by President Kerper of the Mt. Adams and Eden Park Inclined Ry., Cincinnati, as reported in the July GAZETTE, has already attained such a degree of popularity as to receive the commendation of the Street-Railway Association of the State of New York, at its meeting Sep. 20th, as reported in the October GAZETTE. One argument urged is that if the officers of U. S. mail street cars, and the public, could feel that they had the strong arm of the government to protect them there would be less obstruction and interference by trucks and other vehicles. A special committee was appointed to attend to the matter; and it is not improbable but that a rush may be made on the postal authorities by street railway managers all over the country for admission into the great postal service of the United States.

"YERKES in the Courts" is the phrase that has recently gone the rounds as a caption to newspaper reports of judicial proceedings concerning the whilom North Chicago deal. Messrs. Goudy and Green, the attorneys for Volney C. Turner, made a plea before Judge Gary recently, in the suit of George Schneider and others against Turner, that an agreement by Turner to sell a controlling interest in the North Chicago City railway company was a gambling transaction and hence void. The agreement was made in 1885 between Turner, then president of the company, and George Schneider, Walter L. and Ferd W. Peck, by which he agreed to sell them 1,786 shares of stock for \$188,400 cash and \$883,200 in one year at 5 per cent. The Yerkes-Widener combination stepped in, however, and bought the road. The Pecks and Schneider claim that it was a clear breach of contract by Turner, and sue for \$600,000, while Turner, besides setting up the gambling plea, asserts that the deal was to be consummated by a definite answer from the plaintiffs Dec. 12, 1885, but that such answer was not given. It was contended that as the stock is a commodity which fluctuates upon the market, and was to be bought for speculative purposes, such a contract was in violation of section 130 of the state laws. The attorneys for the plaintiffs maintained that this was nonsense. If it were so every business transaction between Chicago merchants would be gambling. Judge Gary said he did not think that this contract came within the spirit though it might be within the letter of the law. He would want to hear arguments, however, before it was decided, and the matter went over. Mr. Yerkes withdrew his demurrer in Judge Jamieson's court to Stockholder Robert W. Rolonson's bill to annul the lease made by the North Chicago City railway company to the North Chicago Street railroad company, and was given thirty days in which to answer the complaint. The move signifies that Mr. Yerkes wants to cease skirmishing and come to the final engagement so as to get the matter out of the way.



## AMERICAN STREET RAILWAY ASSOCIATION.

(Continued from page 227.)

*The Girder System.*

As we found that England originated the stringer system but left it to us to develop; so we find that she originated the girder system, and left it to us to develop it as to bring it within the range of the American roadbed construction and the American pocketbook. In 1866, England first developed the girder system by replacing the stringer with metallic construction, and so perfect are their roadbeds that the benefit of a long living track construction under these circumstances was such that at once it was taken hold of and developed there almost regardless of cost. We consequently find that, though possessing a comparatively small mileage as compared to ours, the English have a great number of different sections and different systems in use. But in the main their system is one that, in cost, is prohibitive, and in type not suited to our practice, the depth of rail being from 7 to 7½ inches, the head narrow, and the lower flange very wide. It is from 80 to 100 pounds per yard, most of which weight is buried.

We took up the problem in this country in 1872, and, as with cable roads, so with girder rails, California was the originator of the improvement. The rail used there was of shallow depth, and narrow, and while it has answered well the purpose in San Francisco, it needed improvement to be generally adopted elsewhere. This was forthcoming, and to-day we have many different systems and as many different sections of rails as there are letters in the alphabet. We are advised that at this writing there are over 1,000 miles of girder track construction in use in this country. It is not our purpose, nor is it, perhaps, the province of this convention, to pass judgment upon patented specialties or to discriminate between different makers; but we have already gathered sufficient experience to outline in a general way what is the desideratum of a good and available construction. The American girder system may be classified into three types:

First, That provided with a depth of girder that permits of direct attachment to the cross ties below the paving sets.

Second, That in which the depth of girder is governed by considerations of strength and stiffness only, and in which connection to the cross tie is made by special attachments.

Third, That in which the girder is of a minimum depth, and which depends upon a supporting medium, *e. g.*, longitudinal chairs, etc., for stiffness. The web or girder in this case being a means of connection to the subway and not materially acting as a stiffener.

Of the three classes, the greatest amount of success has been with the second. It has been found most economical to reach a full amount of stiffness and stop there. It has been found that ample stiffness can be secured long before reaching the depth of the cross tie. And it is certainly more economical to use a supporting device over the tie, say from every five to every six feet, than to bury a useless amount of material the whole length of the rail. Against the third class may be urged the fact that the rail being more or less flexible, its stiffness must be dependent upon the subway and its connections thereto, *e. g.*, bolts, keys, etc. No one knows better than the street railway man what flexibility means in a roadbed. The experiments in the direction of the third type have not been followed by any extensive use. We will, therefore, deal principally with the second class. The first demand is a rail that in its own construction shall be capable of sufficient rigidity to hold its true alignment under the heaviest loads. The experiments made by a valued member of this association, Mr. Augustine Wright, emphasize this. His experiments show that, whereas with a good track it takes 15.6 pounds per ton to move a load, with a track in bad condition it calls for 32.3 pounds per ton. This means twice the amount of work for our horseless, and greatly increased wear and tear on the running gear. A depth of about 4½ inches has been found amply sufficient to give the desired stiffness, provided the form of the rail is double flanged. The provision of the lower flange approximates the rail to the shape of the Hodgkinson beam, which, as is well known, gives the greatest amount of stiffness with the minimum of weight. Having secured this depth, it is folly to go further. If any increase of weight is called for, better put it in the head, where it will repay its presence by greater wear.

The next point in order is the connection of the rail to the cross tie. We have found a great diversity of opinion on this score. The rail is attached by supports called "chairs," and we find that a chair which has given entire satisfaction in one case has been found yielding in another. We find one man using and recommending a heavy and substantial chair, and another that considers it too heavy and a useless expense. After sifting it all down, it seems to resolve itself very largely into a purely local question—with a track subject to extremely heavy usage, a substantial heavy chair will be a wise investment, particularly if the supporting roadbed be defective. With a track subject to light usage a lighter chair will answer.

One point is worth noting. It seems to have been demonstrated that the province of a chair should be well defined. It should be used to support the track only; never as a joint if it can be avoided. In such cases, where the exigencies of construction force its use as a joint, it should be of ample width, never less than 18 inches. Upon this subject we have before us the experience of the steam railroad, and it is safe to say that the joint which has been found best by them will be found best in the street railroad man's effort to assimilate his practice to theirs. For, after all, what is the girder system but the adaptation of steam railroad practice to street railroad needs, and what better guide can we have than the experience so dearly and thoroughly acquired by our steam railroad friends?

A joint should be of the fish plate type. It should, when tightened, hold the rail both ways. It does not merely suffice to hold a joint up; it

must also be held down, and should be of such construction as to keep the two ends of the rail in alignment, no matter what defects or flexibility may otherwise exist. Many experiments have been made in this country to avoid the fish plate joint, but so far none of them have reached the same measure of success. If necessary to use a rail devoid of the lower flange, a rib or button should be provided on the lower edge of the web, to enable the use of the fish plate at the joint. And it may be added that the same experience largely applies in such a case to the chair—in fact, to every connection no matter of what sort. When the connection provides against movement both ways the structure becomes more nearly homogeneous than can otherwise be the case. A connection which depends upon the fit of a bolt or a key is always liable to work loose. As to the shape of the head of the rail, it can only be said that this must vary with local and municipal requirements and the habits of the community, though it may be perhaps well to note that in Boston, Rochester, Buffalo, and many points in New England, a rail has come into extensive use, which may be defined as a "naturalized" English groove rail." It is less obstructive to passing vehicles than the side or center bearing rail, as the width of its upper surface is less, and the curved outer tram nearly approximates the level of the head. It is purposely not made quite level, and for reasons that have been already pointed out.

First, Because where the paving settles in case of defective streets, and in our streets it does settle, the small difference safely guides a vehicle that is tracking on the rail, over the defective points. It is well known that very little suffices for this; and as one side of the groove is lower than the other, it does not hold dirt or snow to anything like the extent of the English rail.

Second, Because the slightly lower tram brings the scope of the groove below the head, and permits of the groove entirely filling without lifting the tread of the wheel off the head, and thus making the cars track hard.

It seems that in this rail the difference in level of tram and head, while too small to make the head obstructive, is sufficiently great to offer the advantages named. It seems to be giving thorough satisfaction.

We will close with one word about the cross tie. Even this has of late years been constructed of steel, and a few forms are now in the market at a reasonably economical price to tempt their use. But as will be seen by a reference to the report on track repairs, made to this convention in 1885, the life of a cross tie, when buried to a depth of eight or nine inches, is very great. So great that we incline to think the use of the metallic tie a luxury rather than a necessity. When we reach the Arcadia of perfect pavement, we can, perhaps, afford to put in such a weight of rail as will by its great life justify the use of a metallic tie. We have not reached that yet.

The time is fast approaching, if not already here, when electric motors will come into general use for the propulsion of our cars. When accumulators or storage batteries are used, our cars will have to carry an increased weight of 3,000 to 4,000 pounds. It is probable, also, that in time we shall find it profitable to replace our present cars with longer ones, capable of seating a larger number of passengers; all this will require heavier rails and better road, and we shall have to construct our tramways when building new tracks, or reconstruct our old ones, for this purpose. A section of rail weighing from 55 to 60 pounds, with the cross ties placed four feet apart, will be sufficiently stiff to answer the purpose. Great care should be exercised, however, to have every part of the track construction well and solidly done, especially at the rail joints, and the whole track rigidly held in place, so that inaccuracies in this respect will not cause the motors to leave the track, nor settle it and throw it out of place, by the increased weight and speed of our cars. In the light of the present progress of the electric motor system, these facts seem worthy of our consideration. For the committee,

C. A. RICHARDS, Chairman.

MR. CHAS. B. THURSTON, of Jersey City, N. J., referred to the subject as one of much importance, and to the paper as an able one, in which the different systems of track-laying had been reviewed. If it was proposed to accommodate the convenience of the ordinary street traffic in the cities, and to ignore the comfort and interests of street railway passengers, and also the advantages to be derived by the tramway companies, then the groove rail would be preferred for use. This rail, in his opinion, was not one adapted to our climate. While it might be serviceable in the South, it would not answer in a climate in which the temperature reaches a point near zero. Unless the street railway companies were allowed to use salt on the tracks for the length of the trackway, there would frequently be nothing within sight to distinguish the rail from the street paving.

The speaker maintained that, as in promoting the comfort of passengers in the cars and economy on the part of the railway companies, the center-bearing rail was the worthiest of commendation, the side-bearing rail was perhaps desirable if the object was to accommodate the private team traffic.

Referring to some results which he had secured in testing the girder system, Mr. Thurston said he had used the Johnston girder rail on a steel chair 4½ inches above the cross-tie; the ties being not further apart at any point than five feet and the curves being four feet apart. The traffic upon one part of the rail was equivalent to about two cars per minute, in addition to a very heavy team traffic, but not the slightest leaning of the rail had been noticed. Observation warranted the statement that the fish-plate joint was equal in value to the rail itself. Effort was made to bring the chair pretty close to where the fish-plate joint was located.

MR. WM. WHARTON, Jr., of Philadelphia, said that, up to the present year, the center-bearing rail had been the favorite for general use in New York city, Brooklyn, Jersey City and adjoining cities. It was undoubtedly the best rail for street car purposes. It was, in fact, the



T rail with the stem taken out. The outer flange gives a space which enables the wheels to run comparatively free from impediment by ice, mud or any condition of that kind. This rail, however, had fallen into disfavor with the municipal authorities of New York, and they had made efforts at Albany, last winter, not only to prevent the city railway companies from putting down rails, but to compel them to take up those which had been laid. A truce had lately been called between both parties, and the companies had discontinued the laying of the center-bearing rail. In consequence of this abandonment of it in New York city, where the demand for it had been greatest, dealers had ceased to keep any considerable quantity of the rail on hand, and consequently the supply forthcoming was quite small.

MR. PERIN, of Baltimore, responding to an intimation thrown out by Mr. Wharton concerning the practical requirements of the grooved rail in Baltimore, asked to be excused from a discussion of the subject at this time, as he thought it had already been entered upon at sufficient length by the gentlemen who had spoken.

MR. THURSTON requested Mr. Wharton to state his experience as to the number of men required for keeping the groove clean and freeing it from the wheel flange.

MR. WHARTON replied that he could not state specifically the force required, but that the task was a constant source of expense and annoyance. In the winter time the freezing of the mud in the groove made a very rough road for riding, and necessitated keeping a small army of laborers at work. Unless carted away when removed, the mud would be re-deposited in the groove by the street vehicles, which subsequently passed along the rails.

MR. RICHARDS, the author of the report, also concurred in the opinion that the center-bearing rail is the best in point of construction, as the wheels came directly upon the center of the rail. He ventured to assert that, throughout the country, wherever the old-fashioned stringer system remained, the average track to-day was out of gauge. Referring to the girder system, he spoke of the rail now being laid in Boston as a perfect center-bearing rail, and yet with the groove made so narrow that the street teams do not seek it. It is not wide enough for their wheels to enter it. An advantage in the girder system is that all the fastenings are thoroughly secured and placed under ground. It behooved the street railway interest, in his judgment, to secure solidity of foundation as far as possible. This could be had, together with a long life for the rail, by means of a girder; and thus also a form of rail would be obtained which would not deteriorate because of teams getting upon it.

MR. RICHARDS went on to commend a pattern of rail that is completely center-bearing and with a low groove. Having one side of the flange a little lower than the other, this rail actually cleans itself and virtually possesses all the advantages of the English rail. He congratulated his hearers that, in the march of progress, the old stringer system had disappeared. The profits in the street track laying business had been much enhanced because of this fact.

At five o'clock p. m. the convention adjourned until next morning at 10 o'clock a. m.

At the opening of the second day's proceedings,

MR. MOSES HUMPHREY, president and superintendent of the Concord horse railroad, N. H., pursuant to request, briefly stated his experience in the running of eight-wheel horse cars. He said he had in operation ten of these cars, with wheels varying from 16 to 24 feet. The cars ran easily and heavier loads could be carried in them than could be carried in four-wheeled cars, with the same pair of horses. He had tested the cars for two years. They had surmounted grades of three, five and six feet to the hundred. The eight-wheeled car, especially when of the oblong patterns, ran as prettily and quietly as a Pullman parlor car on a steam road, and, with respect to regularity of motion, was equally as comfortable.

The speaker stated that the idea of the eight-wheeled car originated with himself. The spring used was the same as in the case of the four-wheeled car. It was essential, however, to make use of a strong center-pin, so that the truck would not swing in turning a curve. As the car was hung with a center-pin, it could not be readily lifted with the trucks when it ran off a track, and therefore was not as easily handled as a four-wheeled car. The experiment had, however, been satisfactory in all other respects, and, since it had been put into effect, the receipts from the passenger traffic of the road had been doubled. He confidently believed that any one of his hearers who should try an eight-wheeled car in regular use would be so well satisfied with it that he would prefer it thereafter to a four-wheeled car. He suggested that by putting the wheels on a light wooden frame great economy would be secured as compared with the four-wheeled car.

In replying to Mr. Henry of Missouri, Mr. Humphreys added that the alteration had raised the body of the car about fourteen inches higher from the ground than it was before, and that the same number of horses had done better work since the alteration than was done with the four-wheeled cars.

#### THE VAN DEPOELE ELECTRIC RAILWAY SYSTEM.

MR. CHARLES J. VAN DEPOELE, of The Van Depoele Electric Manufacturing Company, Chicago, at this point, upon the suggestion of Mr. Lewis of Brooklyn, was invited to discuss the system with which he was identified. Mr. Van Depoele, upon coming forward, said he would state merely a few facts in regard to electric railways and their practical operation at present with respect to the cost of running. He thought it would be superfluous to discuss their general practicability. He said that for the last three or four years the Van Depoele Company had expended large sums of money, and had run electric railways with success.

In some instance slight imperfections had been shown, but these oc-

curred not in the electrical parts, but in the mechanical parts. It could be said to-day that the condition of the electric street railway, when ready for the market, was as good as the condition of any ordinary steam engine could be, and that, as a means of propelling street cars, it had come to stay. He then read statistics showing the daily cost of running the roads now being operated under this system. He explained that, where the cost of coal did not exceed \$4 per ton, his company could contract to run an electric road for \$2 per day of eighteen hours. He surmised that the actual cost might not exceed \$1.75 per day. The road could be run at any speed that would be permitted by local authorities. Upon the road in Scranton, Pa., an average speed was maintained of about fifteen miles per hour.

The overhead wire system could be established in small towns for about \$1,000 per mile, whereas the cost of an underground conduit would be from \$5,000 to \$10,000 per mile. A practically good conduit could be made for about \$6,000 per mile. He thought that, in any combination which might be formed between the conduit system and the overhead wires, arrangement could be made by which the cost of the plants would be kept at a reasonably low figure.

MR. LEWIS (Brooklyn) inquired as to the cost of maintaining the motor in use. And MR. VAN DEPOELE replied that the depreciation of the electric motors, so far as statistics showed, would not exceed two per cent. per annum. Ordinary machinery running in a shop depreciates at the rate of from two to five per cent. per annum. The wear would be rather upon the running gear than upon the motors.

MR. VAN DEPOELE, in reply to inquiries by Messrs. Littell (Louisville); Clegg (Dayton, O.); Cronyn (London, Canada), and others, made the following additional statements. The company has not now in operation a combination of the overhead and conduit systems, but is constructing one such combined system in Dayton, Ohio. The connection between them would be worked automatically. As soon as the electric railway demonstrates its practicability to the satisfaction of the public, there will be no hesitation in constructing underground conduits, nor any doubt about their success. Electricians can practically insulate an underground conduit as effectively as they can insulate in the overhead system, and even more effectively, because they have a better chance of getting at their work and can construct it in a more solid and substantial manner. In 1884, the speaker said, he put up a small road in Ontario, Canada, on which he used an electrical pressure which is five times higher than the ordinary pressure, and this road has been running since that time without any trouble in insulation or otherwise. It was originally intended merely as a kind of exhibition road.

The conduit proper is to be placed nine inches above the cross tie; that is, from the top of the slot in the conduit to the top of the tie. With the Johnson rail or with the wooden stringer, there will be a slight slope of 1½ or 2 inches toward the rails, which will prevent water from readily entering the slot and will also exclude stones and sand. The movement of watches is affected by their proximity to an electrical machine. This had been remedied in the case of a machine at Scranton by stationing a shield in front of the electric motor. The use of electric machines, however, was not likely to be abandoned because their presence might subject the owners of time-pieces to inconvenience.

Concerning the effect where the conduit becomes filled with water (as suggested by a delegate), Mr. Van Depoele stated that, in making an underground conduit, it was necessary to have regard for insulation. The water must be kept out of the conduit, and provision could be made for this. Outlets could be provided. In the absence of a sewerage system, catch basins could be supplied and these could be cemented so as to prevent water coming in from outside sources, and the gutter could be arranged in such a way as to carry the water along the length of the road. In that way the ground would not, except after long periods, be likely to become so saturated with water as to cause an interference with the conductors. It could be easily arranged to keep the conductors perfectly dry and to keep up the insulation.

With respect to heavy grades, a trial had been made at Appleton, Wisconsin, where there was a ten per cent. grade and a curve of 60 feet. A 15-horse-power motor and a 12-foot car were used there. No difficulty was encountered in ascending the grade, although in the winter time, with snow and ice on the track, the ascent would be difficult. Practically the company had been running on seven and eight per cent. grades, through making use of a sand box. At Scranton, Pa., they ran on seven and eight per cent. grades and around curves without trouble. They anticipated no difficulty from grades of eight or nine per cent. Those of ten per cent. would be a little harder. New methods of traction which would afford the requisite relief might be arranged. No difficulty was apprehended from over-heating in ascending hills, as the motor could be made large enough to meet requirements.

MR. VAN DEPOELE also stated that he preferred using one, instead of two, motors; as a single motor could be placed where it would be most likely to be taken care of, that is, near the driver (the man who runs it). Concerning the gearing, it had been found sufficient to connect only the front wheels. Where heavy grades are to be ascended, the back axle was also connected.

Wherever a telephone or telegraph wire falls on the main conductor overhead, it may be safely assumed that there is general havoc in the telephone or telegraph office. [Laughter.] The electric motor does not experience any sensation from the contact except that, for the time, the line is a little short circuited. To prevent this, a guard-wire is placed over the main wire, where the overhead system is used.

MR. WOODWORTH (Rochester) inquired as to the objection on account of the noise, and the consequences of this in frightening horses on streets or roads.

MR. VAN DEPOELE replied that the noise need not be other than that of the ordinary street car. Ordinarily common bearing had been



used; and this, being of steel and iron, has not only made a good deal of rattle and noise but disgusted many with the electric railroad as it was run in the beginning. By using proper gearing (raw hide is now used for the pinion upon a clear cut larger car wheel), the Spoffard chains do not make any noise. By replacing of the steel pinion with a raw hide or a vulcanized fibre pinion the noise is entirely eliminated. Besides that, the gearing is entirely encased in a box, and this suppresses the noise. These matters are mechanical details which have been productive of troubles, but as to which the causes of complaint have been removed.

The trouble which had been anticipated from accumulations of sleet and ice in winter storms, in breaking the connection on the main conductor, had not arisen. On one occasion, in Scranton, Pa., ice had accumulated on the conductor to a thickness of half an inch. The speaker described the passage of the car and the breaking of the icicles, which he observed at the time; his observation assuring him that the constant current naturally has a pressure sufficient to enable it to go through the ice when this is not too thick.

MR. E. J. BAGNEY, of St. Louis, inquired as to the size of the wire for running twenty-five cars on a double track.

MR. VAN DEPOELE replied that he would use three-eighths copper wire on each track, and would connect the two wires so as to get the combined activity of both conductors. The size of the wire would depend entirely on the number of cars used and the motive power required to do the work.

To avoid a collision, or for any other reason, a car may be stopped within a distance of about the length of the car. Of course this would depend largely on the track and the rate of speed. An actual stoppage can be made within about the length of the car.

A car can be run backward and forward with the same ease.

MR. WINFIELD SMITH, of Milwaukee: Where I live, overhead wires would not be allowed. The practicability of the conduit on the ordinary rough streets of a city seems to me to be in doubt, especially where pools of water or melted snow are to be found. I ask Mr. Van Depoele to say which he considers to be the most practicable method of running cars under such circumstances—whether by independent motors, by storage batteries, or by conduit?

MR. VAN DEPOELE: We would have to consider, as a business question, the comparative economy in the cost of running as between the storage battery and the conduit systems. The question is solely one of dollars and cents, and the cheaper method is the one that should be adopted.

MR. VAN DEPOELE expressed his gratitude for the kind attention he received.

#### MUTUAL FIRE INSURANCE.

President Ackley announced that he had constituted the following gentlemen as the Committee on Mutual Fire Insurance, under the resolution which had been adopted: Messrs. Woodworth, of Rochester, N. Y.; R. Dudley Frayer, of Memphis, Tenn.; A. C. Moss, of Sandusky, O.; Wyman, of New York; V. Cronyn, of London, Canada.

#### SPECIAL MEETING OF THE EXECUTIVE COMMITTEE.

The Secretary, upon the request of Mr. Clark (Cincinnati), read the following report:

"Minutes of special meeting of Executive Committee at meeting held on Wednesday evening, October 19, 1887, at Continental Hotel, Philadelphia.

"The report of the Executive Committee was read. On motion of Mr. Wyman, the report was adopted. On motion of the President the report was approved and authorized on behalf of Executive Committee.

"The question of entertainment of delegates at future annual meetings having been referred to the Executive Committee at the last annual meeting, on motion of Mr. Clark, the following resolution was unanimously adopted:

"Resolved: That the Executive Committee recommend to the Association that that portion of Article XVI of the By-laws, relative to annual dues, be amended by the substitution of the word "25" for "15," on the second line; the object of the proposed increase being to provide for the entertainment of delegates and payment of expenses incidental thereto at the future annual meeting of the Association.

"Mr. Wyman moved that the sum of \$50 be hereafter paid to each committee that prepares a written report to be read at the annual meeting on such subjects as may be determined by the Executive Committee. Carried.

"On motion adjourned."

#### ASSOCIATE MEMBERS.

MR. CALVIN A. RICHARDS: Mr. President—In the line of the action just taken, the effect of which is to increase our annual dues so as to provide for the expenses of the banquet, etc., I would offer the following:

*Be it Resolved*, That the Constitution and By-laws be amended so as to permit manufacturers and dealers in street railway supplies to become associate members of this Association on the payment of a membership fee of \$25, and of the annual dues assessed upon active members; it being understood that the said associate members shall have no voice in the deliberations of the association, except by general consent; and under no condition shall they be permitted to vote upon any matter before the association.

[In accordance with the By-laws, the above proposition contained the signatures of more than five members, viz: Messrs. Richards, Watson Wyman, D. F. Longstreet, Julius S. Walsh, D. F. Lewis and H. H. Littell.]

The resolution was referred to the Executive Committee.

Mr. H. H. Littell, of Louisville, Ky., moved the appointment of a committee of seven (to be named by the chair) to nominate officers for the ensuing year and to select a place for the next annual meeting, with power to report at their convenience.

Pending action on the latter motion, a discussion took place upon a suggestion by Mr. Charles Powers, of Boston, as to the advisability of securing immediate action upon the preceding resolution concerning dealers in supplies, etc., by a suspension of the By-law requiring prior action upon it by the Executive Committee, etc. The secretary (Mr. William J. Richardson), referred to Article XXI\* of the By-laws, and explained that it practically prohibited action by the association at this time, and that the matter must stand over till next year.

#### LEGAL DECISIONS.

Mr. Patrick called attention to the numerous decisions by the courts throughout the country adverse to Street Car Companies, and urged the necessity of adopting some means for embodying such decisions in a volume for reference. He finally moved that the Secretary be directed to compile these decisions in some compact form and deliver them to members of the association, at the expense of the companies or of the association.

A lengthy discussion followed which was terminated by the reference of the motion to the Executive Committee for consideration.

The President here announced that he had appointed the following gentlemen as the Committee on the Nomination of Officers for the ensuing year, viz: Messrs. Littell, of Louisville; Rogers, of Boston; Walsh, of St. Louis; Clemishaw, of Troy, N. Y.; Watson, of Buffalo; A. Everett, of Cleveland, O.; and Winfield Smith, of Milwaukee.

Mr. Littell invited suggestions from the members, for the guidance of the Executive Committee, as to the place of holding the next annual meeting. And invitations were extended on behalf of Detroit, Mich. (by Mr. Henry); Washington, D. C. (by Mr. Clapp); and Minneapolis, Minn. (by Mr. H. H. Littell, in the absence of Col. Thomas Lowry), which was "the second time of asking."

The Secretary read a letter from Mr. Geo. B. Kerper, President of the Mt. Adams and Eden Park Inclined Railway Co., Cincinnati, expressing his regret for being unable to attend the Convention. The letter was accompanied with an account of the recent cable accident, on the lower division of the Walnut Hills cable road, as reported in the October GAZETTE.

At the opening of the afternoon session, the second day, Mr. William Richardson, president of the Atlantic Ave. R.R. Co. of Brooklyn, moved that "the courtesies of the floor" be extended to Mr. Elias E. Ries, electrician, of Baltimore, which was agreed to. And Mr. Ries read the following paper on

#### A NEW METHOD OF INCREASING THE TRACTIVE ADHESION OF DRIVING WHEELS.

At the present time, when the question of substituting electricity for horse and cable power on street railways is receiving such earnest attention on the part of enterprising and progressive railway men, the question of obtaining the requisite tractive adhesion between the driving wheels of the motor-cars and the rails, under all the various conditions of track and weather, is one of considerable importance. This question, moreover, must be satisfactorily solved before any degree of success can be looked for from the introduction of electric motors upon our present street railway lines.

It is well known that one of the greatest obstacles hitherto encountered in applying motors, whether steam, compressed air, electrical or any other kind, to the operation of street railways, has been the difficulty of securing sufficient adhesion between the driving-wheels and track in wet weather, or when the tracks were covered with snow and slush, this being especially noticeable on railways having grades of more than ordinary steepness, such as abound in nearly every large city. In this respect cable and horse lines have always had the advantage, because of the application of the tractive force outside of the car itself and therefore independent of the amount of friction or adhesion between the wheels

\*By-Law XXI. Amendment: All propositions for adding to or altering any of these By-Laws shall be laid before the Executive Committee, which shall bring them before the next regular meeting of the association, if it shall think fit; and it shall be the duty of the Committee to do so, on the request, in writing, of any five members of the association.

and track-rails. As the ordinary street-car rails are necessarily level with the street surface, they do not permit of the same tractive effect as the elevated rails commonly used on steam and suburban railways, and a motor-car running with perfect ease during the winter on a suburban railway would make little or no headway on a city line of equal grade under the conditions before named.

A gentleman widely and favorably known in connection with his work on electric railways, and a recognized authority on this subject, recently expressed his views on the question of tractive adhesion in the following language: "It is nonsense to attempt to run cars on a grade of more than six per cent. in wet weather. It is impossible. No electric car, or steam car, or any self-propelled vehicle will climb grades of more than six per cent. in slippery weather with absolute certainty. If we go beyond six per cent., we must have some artificial adhesion; we must introduce some rack on the road, or cable, which have a positive motion. Any one who attempts to guarantee a self-propelled vehicle, whether propelled by steam or any other means, on grades of more than seven per cent., will most certainly lose his reputation." Substantially the same opinion was expressed by several of the speakers during the session yesterday, one well-known electrician going so far as to recommend the employment of a hill horse to assist the electrical motors on such grades.

While I am not over-ambitious to sacrifice my reputation by contesting such a positive and unequivocal statement, I would nevertheless say that, in view of the fact that many ordinarily level street railway lines have grades of from 10 to 15 per cent., it is self-evident that some method of artificially increasing the frictional adhesion of the driving wheels at such points must be employed before electric motors can be successfully and satisfactorily substituted for existing methods of operating street cars in our populated cities. It was early recognized by the author, while engaged in the development of a system of electric street railways which is now nearing completion, that this question of traction was one of the greatest difficulties that presented itself, and it therefore received prompt and careful consideration, with the result that all difficulties from this source have now been removed and the effective tractive adhesion more than doubled.

This result is produced in two different ways, only one of which will be here described, since this relates more particularly to street railway motors, while the other is intended for use in connection with steam or non-electric railways. I have here a small railway car and track which shows the operation of the method referred to, and which has created much favorable comment at the American Institute Electrical Exhibition, now being held at New York, where it is being exhibited.

You will observe that each axle of this car is provided with a coil or helix of insulated wire, through which a current of electricity can be passed at will. These coils are so arranged that when the electric circuit of which the coils form a part, are closed, the iron axles are powerfully magnetized in opposite directions with respect to each other, the wheels forming an extended pole piece to their respective ends of the axles. Consequently, the polarity of each wheel is the same at any point of its periphery, and rolls upon the rail without the retardation that would otherwise take place. The magnetic circuit between the two axles is completed through that portion of the rails lying between them, thus offering a constantly closed and uninterrupted path for the magnetic lines of force. The practical result of this arrangement is to convert each wheel into a powerful magnet, which adheres to the rail with a firm grip and offers an extremely large resistance to any slipping or skidding tendency. The amount of adhesion thus produced is under perfect control of the motorman, since it is dependent upon the strength of current flowing through the coils, which can be regulated at will or cut off altogether when not required.

In the model before you there is an arrangement by which the track can be elevated at one end to represent inclines of different grades; also a dynamometer for measuring the tractive force exerted. When the car is running on a level track you will notice that its tractive power is nearly three times as great when the circuit through the coils is closed, compared to its power with the traction circuit open. You will further see that the car readily ascends a 40 per cent. grade without any slipping of the driving wheels, whereas when the circuit is opened it slides down the grade in very short order, notwithstanding the efforts of the driving mechanism to propel it up. It has been found by experiment that oiling the rails does not materially affect the adhesion due to the magnetic action, although without this artificial adhesion the mechanical friction under these conditions is extremely slight, as may be imagined.

The amount of current necessary to energize this traction circuit in practice is extremely small and insignificant when compared to the value of the result attained, and in practice this current will be obtained from the secondary battery carried by the car for propelling the same, or from a few extra cells carried for the purpose. Until more extended experiments have been made, it is not possible to say to what extent the tractive adhesion of a loaded street car can be increased by this means, but from the experiments already made it will probably be safe to say that the co-efficient of friction can be increased from 50 to 100 per cent. without any increase in weight except that due to the three or four cells of battery required and that of the magnetizing coils, which weight may be practically neglected. The entire apparatus is simplicity itself since it contains no moving part whatever, and it can be applied to any motor-car at short notice. In winter, all that is necessary is to clear off the surplus snow or slush sufficiently to enable the wheels to make a metallic contact with the rails, which can be done by a small brush attached to each car.

The practical value of this simple device as applied to street railway motors is very great, and it is likely to have an important bearing upon the motive power question in view of the impetus it will give to the rapid

introduction of electricity on street railways, since by the use of this method a safe, cheap and reliable auxiliary power is given to every motor-car, a power that it did not before possess, and one that places it on an actual footing with the cable, as far as traction is concerned, on any street railway. No sand and other objectionable traction increasing appliances will be needed, and no wearing of the rails and wheels such as results from the use of sand will occur. This traction apparatus can also be used as a braking force, and a car can be stopped by its means in the shortest possible space of time without jar or shock, and the wheels prevented from slipping or "skidding" on descending a grade.

At this point an informal discussion took place upon the relative steepness of grades operated upon in different cities.

[Mr. Ries had an apparatus on exhibition in room 30 demonstrating his method of increasing tractive adhesion.]

#### THE BENTLEY-KNIGHT SYSTEM.

MR. BLACKWELL, on behalf of the Bentley-Knight Electric Ry. Co., next addressed the association. He said that the company was doing the best that it could to demonstrate the practicability of electric railways. The company's peculiar field, he thought, could be called the Tramway Road. It had endeavored, as far as possible, to solve the question of conduit conduction of power, and was probably the only company in this country that had actually run a conduit or made experiments thereon. The only difference between it and other companies was upon the question as to conduit, as to peculiarities in the construction and setting up of the machinery and in the government and action of the current; as the company had always adopted the double conductor, instead of the single one. Mr. Blackwell went on to say that, as he had already submitted to the members, in an informal way, two papers—one with reference to what the Bentley-Knight Company thought it could do, and the other embodying what the company considered to be the most prominent objections to the storage battery—he thought it scarcely necessary to enter into a discussion of any of the matters contained in those papers. The papers had been handed to the delegates in blue envelopes. Following is the one on the

#### ALLEGED WORTHLESSNESS OF THE STORAGE BATTERY.

AMERICAN STREET RAILWAY ASSOCIATION: *Gentlemen*—The Bentley-Knight Electric Railway Company begs to submit its criticism upon the use of the Storage Battery for street railway purposes.

No idea could be more attractive than that of a self-propelled car, carrying within itself its own energy—independent of any connection with line wires—and dispensing with expensive conduits and unsightly elevated conductors.

On the advent of an apparently practicable storage battery, in 1881, all these advantages were claimed for it. It shortly demonstrated its utter worthlessness as an adjunct to commercial electric lighting, but its promoters claimed that it possessed a peculiar fitness for tramway use. It has been paraded through every city of Europe, and has, to judge from press comments and *ex-parte* statements, never failed to make most successful and startling exhibitions. The boom has now reached this country, and New York, Philadelphia and Boston have each been favored by the attention of the several inventors and their exploiting companies.

Since the European experiments of 1882, little or no material progress has been made in the practical use of the storage battery for street car purposes, and it is our belief, based on most careful investigation, that its radical structural difficulties cannot be overcome. It would be profitless to discuss them here; nor will we dispute the allegations as to weight, efficiency, etc., which the enthusiastic promoters make. We will assume that the storage battery is beyond the experimental stage, capable of driving a car eight hours without re-charging. Granting these most favorable premises, we will make a short practical comparison between the storage and direct systems, both as to operating expenses and first cost. We will also assume that a set of street car batteries will weigh 2,200 lbs.; that they will give a return of 65 per cent. of the electrical energy expended in charging; that a set which will run 8 hours can be charged in 10 hours, and that a set will run 12,500 miles without renewal of the batteries or extensive repairs.

1st. *Cost of Operation.*—Two great losses are chargeable against the economy of the storage system, viz.: loss in conversion of energy in the battery and the additional weight carried on the car. In the direct system, electricity from the generating dynamo is transmitted to the motor on the car by the line conductors. In the storage system, electricity from the dynamo is used to charge the batteries which, in turn, supply the motor. In the latter system the loss is conceded to be 35 per cent. In the former system, it is a matter of simple arithmetical calculation to make the loss inappreciable. It should never exceed 5 per cent., however long the line. This leaves a difference of 30 per cent. against the storage system.

A greater loss is entailed by the heavy load of batteries which the storage system car must carry. It necessitates a heavier car construction



and a heavier motor, all of which adds to the weight. In practice two motors are often used. The additional weight entailed by the storage system easily reaches 4,000 lbs. per car. The motor and driving mechanism for a car, run under the direct system, weighs 1,600 lbs. The equipment where batteries are used is necessarily heavier on account of the added battery weight to be moved, but we will keep the same figure for both. A car weighs nearly 5,000 lbs. In Boston (1886), the average number of passengers per car mile was 10, so that the average load may be put at 1,400 lbs. We then have the following summary:

STORAGE SYSTEM.		DIRECT SYSTEM.	
Car.....	5,000 lbs.	----	5,000 lbs.
Motor, Etc.....	1,600 "	----	1,600 "
Passengers.....	1,400 "	----	1,400 "
Batteries, etc.....	4,000 "	----	-----
	12,000 lbs.	----	8,000 lbs.

That is, 50 per cent. more power must be expended to propel the storage car, and 30 per cent. more power to overcome the loss of conversion in the batteries, making a total of 80 per cent. greater cost for power than the direct system. This means not only 80 per cent. more coal consumed, but 80 per cent. added to the size and cost of the steam and dynamo plant in the generating station.

There are additional losses in the storage system which are less easy to compute, but which are hardly less serious than those mentioned. 12,500 miles are given as the life of a battery. Now 100 miles per day is not an excessive mileage for an electric car, so that the battery must be renewed, wholly or in part, every 125 days, or three times per year. What this would cost it is impossible to say, but it is plainly a serious item. On the other hand the depreciation of an overhead wire, or a conduit, is very slight, not more than 3 or 4 per cent. per annum.

The handling of storage batteries is also a very considerable item. To transfer 3,200 pounds into and out of a car two or three times a day, is not a slight matter, while the shifting and removal necessary to a large plant must be added to it. None but skilled labor could be employed in handling, re-charging and taking care of the batteries. That has been conclusively proved.

2d. *First Cost of the Storage System.*—There is little reliable data on this point, but putting a very moderate estimate upon it, it far exceeds that of the most expensive direct system.

There should be at least three sets of batteries for each car—a considerable increase in the motor capacity—80 per cent. more dynamo and steam plant in the generating station, and twice the floor space, since each car must have a stand for charged and discharged batteries. This could not cost less than \$2,500 per car, which is to be balanced against the conduit and line conductors of the direct system. The cost of the latter varies, of course, with the number of cars per mile. Taking a well-known road in Boston, however, which has 700 cars and 70 miles of track, there are ten cars per mile which, equipped with conduits and conductors at \$4 per foot would cost \$2,000 per car. As a matter of fact, one-fourth of this mileage could be equipped with overhead wire at \$2,500 per mile, which would bring the cost to \$1,650 per car.

An important fact which we have left out of this computation is that most existing roads must be equipped with new and heavier track to fit them for the weight of storage cars.

The present rail will stand an addition of 1,600 lbs. to each car, but not an addition of 5,600 lbs. (The most widely advertised storage car run in this country weighed over 6½ tons.)

These facts are plain and simple, and in view of them it is difficult to see how the introduction of the storage system can be seriously contemplated when conduit and elevated conductor roads on the direct system are feasible. As we have said before, the superficial appearance of the storage battery for street cars is very attractive. It is a simple electrical problem to charge a battery and run a car for an occasional trip. A boat equipped with a battery has crossed the English channel, while for lighting railway trains, where weight and expense are no object, and the work easy and constant, it has a certain value, but for practical street car work, it has just enough promise to make it a dangerous and insidious deceit. The storage power, however, is a disease which users of electricity must go through as a child has the measles. The electric lighting interests went through it some years ago at an enormous expense, and, to-day, not one of the large electric lighting companies is supporting the storage battery. If this paper, hurriedly written and far from complete, will in any degree mitigate the malady to the street railway interests, it will have attained its end. Very respectfully,

BENTLEY-KNIGHT ELECTRIC RAILWAY CO.,  
115 Broadway, New York.

OFFICERS FOR 1887-8.

Mr. William Richardson (Brooklyn), moved that the action of the President in appointing the seven members of the Nominating Committee be confirmed. This was agreed to, and the chairman of said committee announced the nomination of the following officials for the ensuing year: President Charles B. Holmes, of Chicago; first vice-pres. Julius E. Rugg, of Boston; second vice-pres. R. D. Frayser, of Memphis, Tenn.; third vice-pres. Charles B. Clegg, of Dayton, Ohio; secretary and treasurer, William J. Richardson, of Brooklyn, N. Y.; Executive Committee, Thomas W. Ackley, of Philadelphia; Winfield Smith, of Milwaukee; Daniel F. Lewis, of Brooklyn; Charles Green, of St. Louis; and Edward G. Mosher, of Augusta, Ga.

The committee also recommended the selection of Washington, D. C., as the place for the next annual meeting.

After some discussion the committee's report was adopted, the officers nominated were elected by ballot, and Washington, D. C., was selected for the next Annual Meeting.

On motion of Mr. Hurt, of Washington, the salary of the Secretary of the association was increased to \$1,500 per annum.

On motion of Mr. Green (St. Louis), the thanks of the association were extended to Thomas W. Ackley, the retiring president; W. J. Richardson, of Brooklyn, secretary, and to the other officers of the association for their efficiency and fidelity.

On motion of Mr. Woodworth, First Vice-President Rugg, was requested to occupy the chair, the president elect, Mr. Holmes, being absent. Mr. Rugg remarked that the honor conferred upon him was as unexpected as it was appreciated. He expressed his regret that Mr. Holmes was not present.

On motion of Mr. Green, the association adjourned until the third Wednesday in October, 1888.

#### THE BANQUET.

*Philadelphia Memo.* In response to invitation, over two hundred members of the American Street Railway Association and friends attended a banquet at the famous Union League House, on Thursday evening, October 20, which was provided by the Board of Presidents of the Philadelphia City passenger railways. Mr. T. W. Ackley, presided, and assured the guests they were heartily welcome.

#### MENU.

##### BLUE POINTS.

GREEN TURTLE Á LA ROYAL.

*Château Sauterne.*

*A. A. Amontillado.*

BOILED SALMON, OYSTER CRAB SAUCE,  
PARISIENNE POTATOES.

CUCUMBERS.

*Liebfraumilch.*

##### RELÉVES.

FILET OF BEEF AND FRESH TRUFFLES.  
GREEN PEPPERS FARCIE.

SIRING BEANS.

*Pommery Sec.*

##### ROMAN PUNCH.

##### ENTRÉES.

TERRAPIN. SARATOGA CHIPS.

*Veuve Cliquot.*

##### RÔTI.

TEAL DUCK AND CURRANT JELLY.  
CELERY SALAD.

*Chambertin.*

ROQUEFORT. BRIE. CREAM.  
TOMATOES, MAYONNAISE.

##### ENTREMETS.

ICE CREAM Á LA POMPADOUR.

ASSORTED FRUIT. ROASTED ALMONDS.

COFFEE.

*Cognac.*

CIGARS.

*Chartrouse.*

The toasts of the evening, with the sentiments accompanying them, as announced by the toastmaster, together with the respondents, were as follows:

1. "Our Guests." May their shadows never grow less. A cordial welcome to them all to the City of Brotherly Love.—Mr. Charles F. Warwick, the City Solicitor, emphasized and reiterated the greetings of the chair to the visitors in appropriate remarks.

2. "The People's Servants—the Managers of Street Railways." "I serve," the kingly motto, is his by right, because of his hard work in the service of the public.—Mr. Geo. H. Bates, of Wilmington, Del., made a humorous response.

3. "Our Faithful Employees." Men who possess opinions and a will; men of honor; men who will not steal. In our dealings with them may we ever keep before us the motto, "Put yourself in his place."—Mr. William Richardson, President of The Atlantic RR. Co. of Brooklyn, responded; and, in an eloquent and pathetic speech narrated many instances of fidelity and devotion to business and to the interests of their employers by faithful drivers and conductors in his own service.

4. "The Press." The pen is mightier than the sword. The mightiest moral factor influencing the nation's destiny, it is of vital im-

portance that the pen be in the hand of an honest man.—Col. Alex. McClure, editor of the *Times*, responded.

5. "The American Street Railway Association." May the bonds of friendship here formed never be broken.—Col. A. Loudon Snowden spoke of the magnitude of the benefits derived from the street railways.

6. "Our Legal Advisers." "The man who has himself for a lawyer has a fool for a client. Street railroad litigation is a rare field for a lawyer with brains."

7. "Our Patrons."—Mr. John L. Lawson responded, and facetiously remarked that American street cars are never full—in other countries the number of passengers are limited, and when a car is full no more can be admitted, whereas, in the United States, it does not matter how full a street car may be, there's always room for more. [Loud laughter.]

8. "Our Homes."—Mr. Daniel Dougherty, the celebrated "silver-tongued" lawyer, responded; and his speech was the oration of the evening.

9. "Our Absent Friends."—Mr. C. A. Richards (Boston) responded. None but the valorous Calvin could have taken the floor after the intellectual gladiator who preceded him. He referred in touching terms to Mr. Holmes, Col. Thomas Lowry, "dear little" Kerper, and other absent friends.

It was a most elegant banquet, and very charming in its surroundings. A large floral device in front of President Ackley almost hid him from view. Hassler's orchestra added much to the enjoyment of the evening, and among the selections of music was the "Railroad Gallop," composed for the occasion by Prof. Hassler. The programme was an exquisite production of the printer's art. It consisted of four folios, bound in stiff covers, and tied with a band of red ribbon. The frontispiece consisted of a lithographed street car, with a couple of horses going at full speed. Next came the Philadelphia Coat of Arms, with a golden "Welcome"; and that with the titles, "Menu," "Toasts" and "Music" were emblazoned in gold and colors.

"Given to Hospitality." President Ackley provided a long string of carriages—landaus, broughams, coaches, Victoria-Hansoms, cabs, etc.—to convey his numerous street railway friends to see Girard College (where no "minister" dares put his foot); that is a most wonderful institution, with an annual income of \$900,000; the staff, including attendants, numbers about 1,600, of whom 55 are attached to the Department of Instruction; and the students (all orphans) number over 1,360.

Thence the party was conveyed through the extensive and beautiful Fairmount Park, and driven along the bank of the Schuylkill River, ultimately reaching the works of the Electric Car Co. of America, where Mr. Wm. Wharton, Jr., had provided luncheon. The center of attraction there, however, was the electric car on eight wheels, for which a couple of electric motors had arrived from England. But Prof. Reckenzaun and his staff of assistants had not had sufficient time to get it ready. An attempt was made to run it, but it would not work; the "child" from the clouds refused to be coerced or hurried. The ordinary street car, however, was operated beautifully, not only on the experimental track at the works, but it went around the city, filled with visitors, several times very successfully.‡

### The Exhibitors, Etc.

Among the numerous exhibitors of street railway appliances and devices, were the following:

Mr. W. T. Butler, of Boston, had a fine working model and drawings of the Reliable Sand Box, of which illustrations and descriptions have been published in THE STREET RAILWAY GAZETTE. Among the many who took interest in this useful appliance were Mr. Van Depoele and William Wharton, Jr.

The Pierce Duplex Indicator for street, station or depot was among the most interesting exhibits. On account of its extreme usefulness, simplicity and neatness it attracted more than ordinary attention and received much commendation. On horse cars the device is for the purpose of showing at one glance the name of the street on which the car is traveling, together with the number of the corner house and the name of the cross street. The inventor, patentee and manufacturer, W. H. Pierce, of Albany, N. Y., invites correspondence from railway companies. It must

be remembered that the indicator is equally applicable and practicable for "bob tail" cars or belt lines, on cars going and returning by different routes, alternately or otherwise.

Mr. Sheldon Beckwith, of the Street Railway Supply Company, Cleveland, O., placed on exhibition a new trace hook, a track cleaner, the Shattuck improved box, and the Worswick Box. The Street Railway Supply Company, of Cleveland, has the exclusive right to manufacture this box.

The Ries Electric Traction Increasing Apparatus for railways was explained by a fine model. The Ries Electric Railway system, as our readers are well aware, is the invention of Elias E. Ries, of Baltimore, Md. It contains a number of decidedly new and novel features that are claimed to be not only original and unlike anything heretofore produced, but served to render this system among the most attractive to those who are looking for a system that shall combine economy, practicability and efficiency. The system is clearly described in a neat pamphlet, furnished on application to the business manager, Mr. Albert H. Henderson, 27 Chamber of Commerce, Baltimore, Md.

The Greenwood Horse Shoe Company, of Philadelphia, presented an exhibit of its new and improved horseshoes.

The Leib Lubricating Company, of Buffalo, N. Y., through its representative, Mr. Samuel L. Ennis, presented a number of packages containing Street Railway Dux, which is a grease compound thoroughly mixed with wool, that gives it an elasticity, keeping the grease up to the journal. It is composed of the best beef tallow, refined oils, an anti-septic, and an anti-calorific. This grease, at ordinary temperatures, is a thick and pasty mass. It retains this property until heated to 300 degrees Fahr., when it becomes transparent and jelly-like; at 350 degrees it assumes a liquid form. The flashing point is reached at 375 degrees with Tagliavie's apparatus, and at 400 to 425 degrees Fahr. the surface of the liquid grease will burn freely—a high figure. This property of low conductivity will make the grease valuable as a lubricant where the rubbing parts of machinery have reached a high temperature, as in hot car journals.

Illustrated circulars and pamphlets were distributed by the following named parties: The Van Depoele Electric Manufacturing Co., of Chicago; Hathaway & Robinson (railway transfer tables), of Cleveland, O.; Kail Manufacturing Co., Chicago, "combined fare box and change maker"; Kaufholz Bros., Cleveland, O., transfer tables, etc.; The Brooklyn Railway Supply Co., and the Fleming Manufacturing Co. (represented by Mr. Allyn, at the Passayunk Ave. Depot); Augustus Day, Detroit, track cleaner; R. T. White, Boston, acme girder steel street railway road-bed; Jas. R. Swem, Denver, Col., improved street car switch; Frost and Peterson, New York, perforated veneer car seats and backs, etc. (W. P. Seguine, manager); Duplex Supply Co., Norwalk, Conn., duplex registers; J. G. Pennycook, Boston, automatic steam coupler; The Adams and Westlake Manfg. Co., Chicago, street car lamps, and cable car headlights; Hale and Kilburn Manfg., Phila., car seats and springs; The National Stove Co., New York, national car heater; Chadbourne & Hastings, agents for The Sprague Electric Railway and Motor Co., Philadelphia; The Northrop Manufacturing Co. (Sandford Northrop, secretary).

Mr. Horace A. Keefer, of Kansas City, Mo., placed on exhibit W. G. Price's Improved Fare Box, patented June 2, 1885, and September 22, 1885. This box works as follows: Every time a fare is put in, a gong strikes, and it can not be made to strike without putting in a fare. Tickets work as well as money. Every fare drops on the exhibition plate in full view of all the passengers as well as the driver, and has to remain there till another fare is put in, as the driver has no control of it. In order to make the gong ring it is necessary to put something in the box, and just what is put in is exhibited to everyone, and can not be put out of sight by the driver. This effect is not produced by any delicately balanced machinery which would be liable to get out of order. *The ringing of the gong calls the attention of the driver, so he can see who put in the fare and whether it is correct or not. To open the box for cleaning, remove the money drawer and loosen two nuts to be seen back of the drawer.*



**The Whitney Contracting Chill.**

One of the works to have been visited by those attending the Convention, had time permitted, was the car wheel works of Messrs A. Whitney & Sons, Philadelphia. Mr. Whitney had prepared a number of moulds and kept a large quantity of metal liquified in order to show the whole stages a wheel has to go through; and we were greatly edified in witnessing the manufacture of wheels of various sizes, and for various purposes, from the pouring of the metal into the mould to the boring of the axle hole and the testing process. The accompanying cut shows the iron circle, which is placed between the two halves of the sand walls, and against the inner side of which the liquid metal runs and gets its chill. The air passes freely through the oblong holes all around, thus keeping the outside of the ring cool. In the language of the manufacturers' circular, "these chills are so constructed that the heat of the molten metal causes them to contract, instead of expand. This contraction is simultaneous and uniform at all points of the chilling surface. They thus remain in constant and close contact with every part of the tread of the wheels until the full chilling effect required is produced. The depth of chill thus secured does not vary materially in the whole circumference of the wheels; the wheels are practically as round as a turned steel or wrought-iron tyre; and chills that have been in almost daily use for more than a year are found to retain accurately their original shape and size."



**The Messier Car Brake.**

The accompanying cut represents the ground drawing of the Messier brake, which, working on the third wheel,

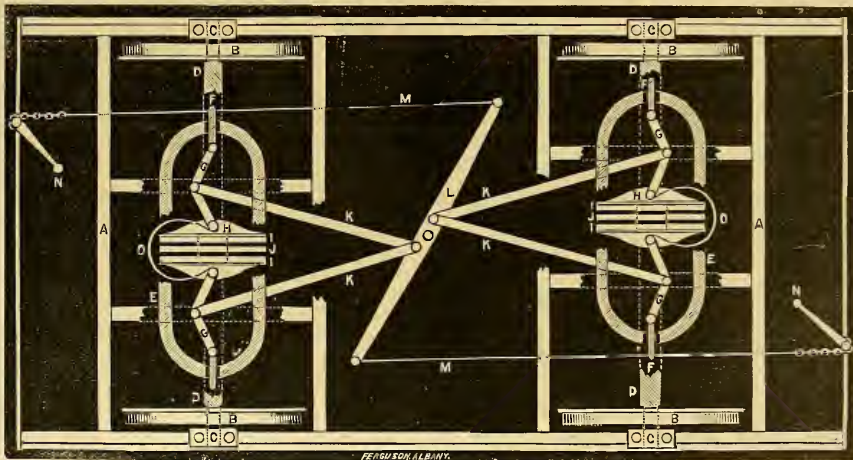

A—Car Frame. B—Car Wheels. C—Journals. D—Axles. E—Brake Frame. F—Adjustable Bolts. G—Toggle Joints. H—Brake Shoes. I—Wooden Facing of Shoes. J—Brake Wheel or Friction Disk. K—Draw Bars. L—Brake Lever. M—Pulling Rods. N—Standards. O—Spring.

and placed at such a height from the surface of the road, renders it impossible to clog with snow or ice in winter weather, and saves the wear of flat places on the wheels. It can be made duplicate, so that it can be applied to one or both trucks from either end of the car, without placing any additional weight on the car.

**The Sprague Gearing.**

Editor of THE STREET RAILWAY GAZETTE. At a special meeting of the American Institute of Electrical Engineers, September 20th, Mr. Anthony Reckenzaun, in an address on the subject of "Electric Street Cars, With Special Reference to Methods of Gearing," referred to the experiments which are (or were) going on at Mr. William Wharton's establishment in Philadelphia, and makes the following statement:

"There we used a set of spur-gearing which was supplied by the Sprague Company. In this case the motor shaft, which runs at from five hundred to six hundred revolutions a minute, carries two steel pinions, one at each end of the shaft, and these pinions gear direct into two cast-iron spur-wheels upon the driving axle without any intermediate wheels. The motor is partly suspended on the axle and partly on the body of the car. We have run several hundred miles with this car under all conditions of load, gradients and weather, on some of the roughest tracks in Philadelphia, but up to this moment not a single hitch has occurred. The gear is perfectly noiseless, it is efficient and strong and I see comparatively little indication of wear. The teeth are beautifully shaped, therefore somewhat expensive; but if they last long enough, and if they do not rattle, when partially worn, this expense can be ignored. This car contains, besides its usual weight, about 3,200 pounds of storage batteries. It has to mount grades of five per cent. and run on curves of thirty-five and twenty-five feet radius, which means very hard work."

I wish to correct an impression which one would gather from these remarks of Mr. Reckenzaun, and which hardly do justice to the method of mounting which is there used. The suggestion that the gears are necessarily expensive because of the beautiful shape of the teeth is incorrect; the shape of the teeth has absolutely nothing whatsoever to do with the expense of the gears as we make them, for they are no more expensive than any other form of tooth in cut-gears. There are several reasons other than the shape which make these gears so noiseless; the motor is hung upon the driving axle at two widely distant points and is supported in the centre of the other side by a double compression spring. In

this manner absolute parallelism is maintained between the driving and the driven axle in all planes, no matter what the movement of the axle. There is no twisting or tendency to twist on the face of the gears and pinions; the thrust at all times is absolutely in the plane of the gears and pinions, which are always parallel. The bearings of the armature

shaft are very close to the pinions, so that there is no spring whatever in this shaft. One pinion is set about half a tooth ahead of the other. One of the main gears is fixed; the other is adjustable, so that there is no interference in the thrust of the pinions, and a much more perfect simultaneous meshing of the gears is obtained than would be possible where dependence upon the cutting of the splines is necessary for the adjustment. From two to three teeth on each pinion are always engaged. The proportions of the pinions are such that the armature has to make as many revolutions as there are teeth in the large gears before the same teeth in the gears and pinions engage with each other; and, finally, by reason of the method of supporting, there is always a spring touch, so to speak, of the pinions upon the gears. No matter how sudden a strain is brought upon the motor, it always yields more or less in a direction concentric to the axle of the car, so as to relieve the teeth from all shock. The wear of the gears must be absolutely the same. It is simply impossible for rattling to take place on these gears, even if they were worn down one half their present thickness; and this wear, where the gears are properly protected by screens, will be very light.

The method of mounting, and the general plan of using these gears, has far more to do with their noiselessness and efficient operation than the shape of the teeth, although this shape, being of the involute character, is such that they will mesh perfectly even where there is some change in the distance between the centres of the axles. If it were not for the method of mounting, it would be impossible to run this kind of gearing, as has been frequently done, with variable strains at a speed as high as twelve hundred feet per minute. At no time, under the severest strains it is possible to put on gears of this character, have they ever shown any signs of weakness or undue wear; and in comparison with fixed gears, this method of mounting must necessarily be the most satisfactory.

F. J. SPRAGUE.

### Business Notes.

Wright, Meysenburg & Co. have closed a contract to build a cable road from the Anhauser Busch Brewery to the steam railroad, St. Louis.

THE Laclède Car Co., St. Louis, were well represented at the Convention by the amiable Mr. Sutton. Among recent orders executed are a dozen closed cars for the Chicago Passenger Railway Co., which are on a par with the very elegant and convenient Laclède open cars which have been running on the line named during the past Summer.

KAIL'S Combined Fare Box and Change Maker was exhibited at the Philadelphia Convention. This Change Maker will hold any amount of change up to \$55.00, and is at all times secure from theft, though the driver leave the car. This system does away with the trouble and expense of putting up money in envelopes. One of the testimonials issued in its favor is as follows:

*Office of the Des Moines Street Railroad Co.*  
September 6th, 1887.

KAIL MANUFACTURING Co., Chicago, Ill.

*Gentlemen*—We have now used 24 of your Combined Fare Box and Money Changers for three months past, and our experience with them has been highly satisfactory. The device for making change removes the necessity of putting up change in envelopes, and affords to the passenger a simple and easy method of getting the right amount for his fare. It is alike convenient and effective to the company, the driver and the public, and it should be generally adopted.

Respectfully,  
FRANK A. SHERMAN, Sec.

### Personals.

MR. M. ALEXANDER has gone to Wellington, Kansas, to take charge of the Citizens' Street Ry. of Wellington. He and his family will occupy the house in which Mr. C. W. Hill has hitherto lived.

JOSEPH CHURCHYARD, vice-president of the Buffalo, (N. Y.) East Side Street Railway Co., died Oct. 8, of heart disease.

## Construction, Equipment and Maintenance of American Street Railways

BY AUGUSTINE W. WRIGHT.

### RULES AND REGULATIONS.

FOR THE GOVERNMENT OF THE CONDUCTORS AND DRIVERS OF THE NORTH CHICAGO STREET RAILROAD CO.

(Continued from page 166.)

19. He must not stop at the first crossing of any intersection, on the bridges, or up grades, except to avoid an accident.

20. He will not be allowed to leave his car at the bridges, or at the end of the line, except in the performance of his duty. Going north, he will commence collecting fares immediately after crossing Lake street.

21. When going south he will stand by the rear brake of his car when crossing the viaduct and the bridge, until reaching South Water street, so that in case of an accident he can put on the brake; also, when going north down the grade, when not collecting fares.

22. He will not allow his car to stop at the north end of the bridge, but must go to the viaduct.

23. He will not allow any person to sit on the front dashboard under any circumstances.

24. He will not be allowed to sit on the dashboard south of Division street. He will also keep the rear platform as clear as possible, always asking passengers to step inside.

25. He will not allow smoking on rear platform. He will politely ask smokers to take the front platform, and if they will not do so, will stop the car and have them step off.

26. He will not permit anything to be hung on the brake handle.

27. He must return all articles found in his car to the receiver's office immediately.

28. To prevent accidents and confusion, passengers should not be permitted to ring the bell. The conductor should observe them closely, and ascertain when they wish to get off.

29. All cars must go through on last trip, whether they have passengers or not. When running in, conductors will tell passengers that they are only going as far as the barn.

30. He will be held responsible to the company for all damages caused by neglect of duty or carelessness to the persons or property of others, or to the property of the company.

31. The driver and car will be under control of the conductor, subject to rules for driver.

32. It will be his duty to report to the superintendent or his assistants any driver who at any time attempts to diminish the receipts of the conductor by increasing the speed of the car, or by not promptly stopping for passengers, or for willfully neglecting to obey all proper signals, or who shall directly or indirectly harass any conductor, or be guilty of any other misconduct.

33. Each conductor will be required to have a copy of these rules and regulations with him at all times when on duty, and to make frequent study of them, and to be found familiar with them, and when he leaves the employ of the company will be expected to return them to the office.

34. If occasion requires any amendments or additions to the above rules and regulations at any time, such amendments or additions will be found posted on the various bulletin boards at the superintendent's or receiver's office.

35. Any willful or careless violation of the above rules and regulations will be deemed sufficient cause for discharge.

36. IN REGARD TO BELL RINGING.—With a view to the prevention of accidents, all conductors employed by this company will observe the following rules; and any conductor or driver who hereafter fails to obey them in every particular, will be immediately discharged from the service of the company.

*First.* Keep your hand off the bell strap, and place yourself as near the step as possible, ready with both hands to assist passengers on and off the car; do not pull the bell strap until the passenger is fully on the platform.



*Second.* Never pull the bell strap while passengers are getting off the car; wait until you see plainly that they have got safely off the car, before you start again. Do not ring the bell from the inside unless the car is crowded so that you can not easily get out to the platform, in which case you will inquire in a loud voice if all is right and wait for an answer. It is a custom with conductors to neglect stopping their car when gentlemen, especially young gentlemen, approach with the intention of getting on; this is wrong and will not be permitted. The positive orders are to stop your car as soon as you see persons coming to get on, and then wait until they are safely on the car before ringing to go ahead.

*Third.* Hereafter, in case your car comes to a stop at any crossing, curves or cross track, or being shut or cut off by teams, you will not allow your driver to start the car without being signaled by you. Conductors will not stop their car for passengers to get on or off only at the farther crossing of any street and in the middle of long blocks where sign is placed; nevertheless the drivers must stop their cars always at the signal of the bell.

By proper observance of these rules accidents will be largely prevented. In case of any neglect, discharge will surely follow, and no excuses will be accepted.

#### RULES FOR THE USE OF THE ALARM REGISTER.

1. When time to collect fare, conductors will commence at the forward end of the car, and fares must be collected in tickets or cash from every person over five years of age, except regular city police and firemen when in full uniform; otherwise collect fare from them.

2. The register must be used to cancel and record each and every fare collected by him. When one or more fares are paid he will record them on his register in the presence of such person, and record such fare or fares before another is taken up.

3. Employes of this company will ride on employe's badge. Any employe of this company failing to provide himself with employe's badge must pay fare or leave the car.

4. Complimentary book of tickets will be issued. These books will bear the name of the persons to whom they have been issued, and the conductor will be particular to see that they are used by no other persons. If presented by any one but him whose name it bears, the conductor will retain the book and return it to the office. The ticket must be detached and cancelled from this each time it is presented, and accounted for in the column of "Free."

5. Any failure on the part of conductor to have employes show their badge or collect fare from them, will be considered sufficient cause for dismissal from the service of this company.

6. He will on no account pass persons over the road because of their having been in the employ of this company.

7. He will keep his register and badge in a clean and bright condition.

8. Any conductor neglecting to set his register back to 0 at the end of each half trip will be discharged.

9. He will return his money and trip sheet to the satisfaction of the receiver. Any information which he may require in reference to his trip sheet, register, time and mode of settlement, will be furnished by the receiver.

10. Any failure on the part of conductor to fill out his trip sheet before returning it to the office, will be considered sufficient cause for dismissal from the service of this company.

11. When the conductor comes to the office on his last trip at night, he will return to the receiver his register and amount of his collections.

12. Should a conductor lose a register or injure one by tampering with it, he will be required to pay twenty-five dollars for it, also pay for any damage to it by carelessness. He will not retain the register in his possession over one hour when off duty. If for any cause he be relieved from duty, either by order or by sickness, or of his own accord, he will at once turn in his register at the receiver's office. He will on no occasion loan his register or allow it out of his possession without the consent of the superintendent or his assistants.

13. The conductor will be required to account for the number of fares indicated on the register, and will be required to pay the highest rate of fare for all that are short by the register.

14. If at any time the register does not work perfectly, the conductor must report it at the office immediately, and procure a perfect working register in exchange.

15. If the conductor runs but one trip and returns the amount of his collections and his trip sheet, the register must be returned also, so that the sheet and the register can be compared.

16. He will be required to have ten dollars in change at the close of each day's work as a bank for next day.

17. Any violation of the foregoing rules will be considered sufficient cause for prompt dismissal from the service of this company.

#### DUTIES OF THE DRIVER.

1. He is to be cleanly in personal appearance, make use of no profane or obscene language, and is to abstain from smoking, from the use of intoxicating drinks, and from all improper conduct and unnecessary conversation with passengers. He must not visit any saloon while on duty.

2. He will see that his horses are properly harnessed before starting, to avoid stopping on the road. He is to start promptly on time when directed by the conductor, drive according to directions and conform to the running time, and avoid "loafing," or crowding with other cars.

3. He will not leave his car anywhere on the road, to get refreshment, or for any other purpose not actually necessary, without notifying the conductor. He is to keep a vigilant lookout for passengers on the corners and cross-streets, for carriages, cars, trucks, and especially pedestrians, to avoid accidents.

4. The proper position for a driver is to drive with as tight a rein as his team will permit of, and to hold his reins in his left or bridle hand, with his right hand on the brake, thus enabling him to have instant control over his team and car.

5. He must pay particular attention to brakeing-up his car when approaching a team or carriage on the track. He must be sure to brake-up in season to give the team or carriage sufficient room to get out of the track, if the wheels of the car should slide.

6. He is to drive slowly over all curves, switches and turnouts. At points where two tracks unite, he must drive with great caution. Racing is strictly forbidden on any part of the road. In case of a collision, at the junction of two tracks, the drivers of both cars will be discharged.

7. He will avoid running his car close up to the car in front when he is blocked up on the street; there should always be room for teams to pass between his horses and the car in front.

8. He will always stop his car whenever any person wishes to get off the front platform, notwithstanding what they may say to the contrary. He must notify passengers that it is a violation of the rules for them to enter or leave the car by the front platform.

9. Before starting his car, when the conductor is not on it, he will look and see if anyone is getting on or off. Particular attention is to be paid to the bell, and the brake is to be kept on until the conductor strikes the bell to start.

10. He will keep a good lookout for passengers on his route, and stop the car as soon as possible and proper, when asked or notified so to do.

11. He will at all times be courteous and polite to passengers, answering proper inquiries for information, and use especial care when passengers insist on getting on or off the car by the front platform.

12. He is to stop the car in taking and letting out passengers at the further cross walk, in going either way, and not start his car until notified to do so by the conductor. Whenever a passenger gets on the front platform, he must immediately ring the bell for the conductor to come for his fare.

13. Cars running in different directions should not stop abreast of each other, except at stations, or when transferring passengers. When cars are passing one another the

drivers should slacken the speed of their horses, and gently put on the brake, to guard against running into persons who may be crossing the street, in the rear of either car.

14. In all places where the street is dug open for paving or other purposes, so as to endanger the safety of their horses, they must be detached from the car.

15. ACCIDENTS.—He will use the utmost care in controlling the team and car so as to prevent any kind of accident, either to his horse or car, or to other horses or teams by collision, or to persons or passengers getting on or off the car, crossing the streets, or in any way liable to be injured by the horses or cars of the company.

16. In case of any accident, however slight, to persons or property, he is to note all the circumstances within his observation, and at once give the facts, and names of any witnesses he may obtain, to the conductor of the car.

17. He will be held responsible to the company for all damages caused by neglect of duty, or carelessness on his part to their property, or to the person or property of others, for which the company may be held responsible or liable.

18. Any driver who may be found wilfully or recklessly violating any of the above rules, will, upon sufficient proof, be immediately discharged from the service of the company.

19. Drivers are especially directed to make frequent and careful study of the above rules; and especially of those pertaining to accidents to persons and property; and to have a copy of the rules at all times in their possession.

20. Drivers when riding on the car when off duty, must show employee's badge to the conductor or pay fare. Badges can be had at the receiver's office.

21. Any driver refusing to show badge or pay fare when asked by the conductor, will be discharged.

22. When wishing to report for duty, he will report to the assistant superintendent before five o'clock p. m.

23. He will not be allowed to drive faster than time gait on his last trip.

24. He will not be allowed to drive on the bridge after the bell stops ringing.

25. He will not be allowed to drive faster than a walk down grade off the bridge or viaduct.

26. Two cars must not meet at a switch; cars going in town will have right of way.

27. At the crossings of all railroads where steam locomotives are used he will stop his car fifty feet from it, to give his conductor an opportunity to go ahead of his horses, see if any danger exists, and in no case attempt to cross unless notified to do so by his conductor, who must be upon the track ahead of the horses at the time he gives such notice, and under no circumstances place his car in a position of danger. Any driver violating this rule will be discharged at once.

#### SIGNALS.

One sound of the bell to stop the car.

Two sounds of the bell to start the car.

Three sounds of the bell to drive faster.

Four sounds of the bell to drive slower.

Four or more sounds of the bell to notify teams that are in the way.

#### TO CONDUCTORS AND DRIVERS.

Conductors and drivers should bear in mind that a full compliance with the foregoing rules and regulations will be expected of them.

Particular attention is called to Rule No. 5 for conductors. It is a common thing to see the platform crowded when there are seats inside, and it is the cause of great annoyance to ladies entering and leaving the car, and no gentleman will refuse, if politely asked, to observe so just a rule. See that your car is filled, and never allow a passenger to stand, if you can provide a seat. The conductor who is most successful in enforcing this rule will be duly appreciated by the company.

The careful observance of Rule No. 7 for conductors, is also very important. Injustice is often done to those who suffer, as well as to the company, when they are not fully apprised of all the circumstances of any accident that may

happen. You cannot be too particular about obtaining the names and residences of witnesses.

Finally, conductors should carefully regard Rule No. 3, for the use of the alarm register. The company will expect you to account for every person that rides upon your car, and that you will allow no one to pass without paying fare, except such as are entitled to.

F. L. THREEDY, *Superintendent.*

(*To be continued.*)

### Street Railway Horse Doctors.

The street car horse doctors of New York City have been honored with a prominent paragraph in the new promising daily, *The Evening World*. It may not be generally known, it says, that every large car stable in this city has its regularly employed veterinary department, whose duty it is to attend to all ailments and mishaps of the horses, and who have by no means an easy time of it. In fact, the hospital ward, as it is called by the drivers and stablemen, is usually pretty well filled up with disabled animals, and the horse doctor has his hands full of responsibility. One of the largest stables in the city is that of the Third avenue line at Sixty-seventh street. The average number of horses kept in that stable is about seventeen hundred. It is well known that a horse could be put to no more racking and wearing work than dragging horse cars, especially over so long and tedious a route as the Third avenue. For this reason the number of disabled horses on this line is always very large. The large hospital room, which is connected with the station, is always well filled with equine patients, and according to the veterinarian of the line, the number is generally in the neighborhood of one hundred and fifty. The troubles of the animals principally arise from strains and wrenches which they receive in pounding over the cobblestones, and they are very seldom disabled by sickness or disease. Occasionally they get overheated in the summer, and that necessitates laying them off for a few days or weeks, but usually their feet and legs give out, their muscles get puffed up and stiff, and then they are at once sent to the hospital. Sometimes, too, it is owing to carelessness or cruelty of drivers that a horse is disabled. Whenever an animal is found to be injured in any way he is at once put on the sick list and turned over to the doctor. If he is a young horse and has not been hammered and pounded too much, a few days, or a week at the most, will put him in condition again. However, if after a few experiences of this kind it is found that he cannot be brought around so easily by poultices and plasters, and eventually the joints begin to stiffen and swell up and he is pronounced unfit for further car work and turned over to the salestables.

The average period of usefulness of the car-horse is about three years. A few extraordinary tough brutes can stand it ten or twelve years. In fact they have a horse now in the service of the Third avenue company which has survived that time. His name is Billy, and he is an old white horse. He does not look by any means as broken down as a great many of his younger companions. In car pulling, as in a variety of other pursuits in life, it is evident that a good deal depends on the way it is done, and Uncle Billy seems to have discovered how to do it without undergoing the usual physical risks that are popularly supposed to be unavoidable in this occupation. Not a few horses, however, wear out within six months after they have been put on the road, and must be sold again for country work. It is the province of the veterinary surgeon to decide when horses are laid up whether they shall be returned to work again after being patched up, or whether they are too far gone to bother with. In every case he decides in favor of the horse, because the company is very particular with regard to its live stock, and it would not do to show any lame or broken-down horses on the street. When a horse is no more use to the company, as has been said, it is sold. The prices usually brought are from \$25 to \$35 apiece.

EIGHT wheeled street cars are highly spoken of by those who have tried them, they run more easily than the four wheelers now in general use.



# The Street Railway Gazette.

VOL. II.

CHICAGO

DECEMBER, 1887.

NEW YORK

No. 12

## President John E. Bailey.

Mr. John E. Bailey, the newly elected President of the Ohio State Tramway Association, was born in Vermont, in 1817. Two years later his parents brought him to Ohio, when school houses were built of logs, and John E. received an education as good as the common schools of those pioneer days afforded. At the age of 17 he left school; and, after spending three years "merchandising," went out to Missouri, but returned again to Ohio the following year — with his wife. He then bought some land, cleared it up, and took to farming, which state of things continued until '48 when he turned his attention to ship building, and in '65 he and his brother started in that business together, in Grand River, near Painesville, Ohio, under the firm name of Bailey Brothers. Three years later it was thought advisable to move to Toledo, which had then become an important place, and Mr. Bailey's connection with the concern continued until about four years ago.

In the fall of 1874 Mr. Bailey purchased some stock in the (then) Toledo Street Railway company — and was elected president the following January. Eleven years later this company effected a consolidation with Adams Street, Dorr Street and Monroe Street lines, when it became known as the Toledo Consolidated Street Railway Co., with a capitalization of half a million. Mr. Bailey was made president of the new corporation at its first meeting, which office he has held ever since.

## Ries' Electric Motors.

The Providence (R. I.) Board of Aldermen are considering whether to grant an ordinance for a cable road or give the preference to electricity. Our friend Mr. D. F. Longstreet appeared before them Dec. 2, and said: "The cry which a year or two ago was for cable is now turned on the side of electricity. Its advocates certainly captured the Philadelphia Convention; and by their statements and exhibits made many 'who came to scoff remain to pray' there might be something in it. The exhibit which pleased me above all others was that made by Mr. Ries, of Baltimore." The inventor (Mr. Ries) and his business manager (Mr. Henderson) were present, and explained (with model) the new Ries electric traction-increasing apparatus for railways — which has been described and illustrated in previous issues of the GAZETTE. The Reis system is likely to get there.

## Chicago Wants Rapid Transit.

When horse railways first came into use, they afforded "rapid transit" — that is what it was then called — and people were delighted therewith. As society became used thereto, street cars came to be looked upon as slow coaches. That however, is the way they are described just now in Chicago, by those who have new lamps to offer for old ones; or to speak more definitely, they declare that street railways (on the surface) are not "rapid transit;" not even the cable cars can give satisfaction any longer. Chicago must have elevated railways. The enormous profits realized by the Chicago West Division Railway Co., as clearly shown through the recent "transfer" thereof to the Philadelphia millionaires, has induced lively newspaper articles, correspondence and squibs relating to "the rich West Division nickel mine," and other great magnates, very anxious to increase their wealth, have commenced operations to "create" public opinion on that wonderful West Side, in favor of "L" roads. A lawyer convened a meeting, a long way to the west of the city, which was made to appear as the result of spontaneous public feeling, and a "mass meeting" of the property owners was arranged for subsequently; but in the interim the Chicago Rapid Transit company was incorporated, and an attempt was made to father it on "public opinion," whereupon General Martin Beem, the eloquent attorney of the Arcade Rapid Transit Co., whose ordinance (for an underground railway along Monroe street) has been before the City Council since March last (as stated in the April GAZETTE,) denounced

the movement as deceptive. Thereupon Alderman Kerr (the chairman of the meeting) opened the secret, and the "company" was thrown upon its own resources, while the West Side Rapid Transit Association has been organized, with "good men and true" directing its work, which is to watch the interests of the public in general, and of the property owners in particular; they are investigating various schemes for securing "rapid transit," and will meet daily, as long as necessary, at the Grand Pacific Hotel, to examine all plans that may be presented to them. The systems hitherto examined are the Sherman, which is a modification of existing systems; the Meigs; the Richards, and the Adams. The latter is described and illustrated in our present number. By invitation they have visited the Bidwell electric railway.

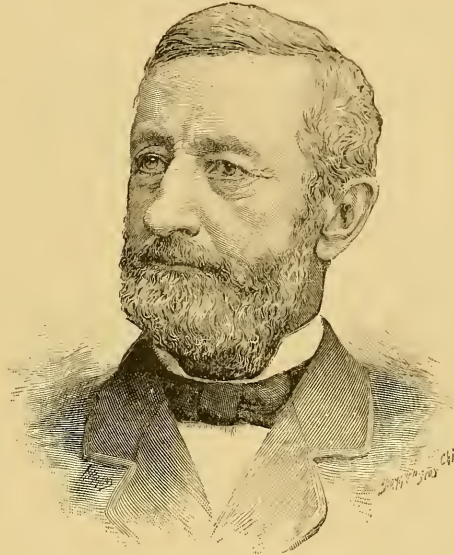

*John E. Bailey*

## Boston Street Railways; Year Ending September 30, 1887.

	Stock Holders	Capital Stock.	Total Debt.	Property and Assets.	Passenger Earnings.	Total Income.	Expenses.	Net Income.	Passengers Carried.
Boston Consolidated	216	\$2,000,000	\$1,598,112	\$3,485,550	\$1,094,410	\$1,115,337	\$ 930,630	\$255,592	22,834,215
Metropolitan	260	2,000,000	1,603,468	4,444,438	2,113,132	2,200,248	1,861,430	408,318	42,970,280
Cambridge	216	1,950,000	807,418	2,804,751	788,874	803,102	712,951	127,657	14,918,663
South Boston	111	750,000	404,424	1,086,475	539,440	546,333	496,442	69,494	11,085,052
Lynn & Boston	125	300,000	595,532	859,185	457,284	462,642	407,648	77,665	8,671,110

Above are the statistics gleaned from the official reports, as far as they have been returned to the Railroad Commissioners, of the principal street railways of Boston. The capital stock is that authorized and paid in each case, except that of the Boston Consolidated, of which \$1,700,000 is the sum paid. The Lynn & Boston has \$300,000 paid and authorized by vote, while \$500,000 is authorized by charter. The net income in each case includes "interest accrued." Of the 1,912 cars of the five companies, 1,038 are box and 874 open cars. A peculiar feature of this year's returns, compared with those of the previous year, is the very marked reduction in the number of stock-holders; last year the Boston Consolidated had 800 stock-holders, the Metropolitan 1,086, the Cambridge 869, and South Boston 468, total (of the quartet) 3,223; whereas now they report an aggregate of only 803 stock-holders—less than one-fourth of the previous number. Probably the shares were bought up, as far possible, by those favorable to the sweeping consolidation with the West End Street Railway Co., which has been fully reported in previous issues of the GAZETTE, and its completion is recorded in our "Pointers" in the present number. Lynn and Boston is not in the "pool," and it has five more stock-holders than last year. The West End Co.'s report, which refers to the time prior to the increase of capital as stated in the September GAZETTE, shows only 15 stock-holders.

It is gratifying to note a reduction in the number of killed on the above lines the past year; one was killed on the Metropolitan, and two each on the Cambridge and Lynn & Boston; total 5, against 8 of the previous year. The number of injured, however, has increased on every road; the total number being 100, against 55 injured the year before.

## UNRESOLVED RESOLUTIONS.

At a meeting of Boston aldermen, Nov. 7, the following preamble and resolutions were offered by Alderman C. W. Smith: "In consideration of the fact that the street railway companies of this city have virtually passed under one management, and that this board has always been led to believe that such consolidation would relieve the blockades of cars in our streets, I would offer the following resolutions:

"Resolved, that, in the opinion of this board, the time has now arrived when a practical solution of the problem can be made regarding the blockades of cars in our streets, particularly Washington and Tremont streets. This board does, therefore, recommend the management of the West End Railway company to take such measures as will, in their judgment, produce such a result as speedily as possible.

"Resolved, that, should no action be taken by the new management of the West End Railway company looking to such a result, this board shall appoint a committee to take the whole subject into consideration, and cause the laws and ordinances relating to this subject, and all other matters pertaining to it to be rigidly enforced without delay."

One of the aldermen considered that these resolutions were an insult to the intelligence of the members of the board. He denied that the street railroads of Boston are under one management. The resolutions were defeated by a vote of seven to five.

Two tracks are all that can be allowed on the elevated railways of New York. Corporation Counsel O'Brien has reported to the board of aldermen, New York city, that a third or central track, for the accommodation of cars held in reserve on Third ave., would interfere with the rights of residents, and is against the spirit of the Rapid Transit Acts.

## Elieson's Electric Locomotives.

Elieson's electric locomotives have been running since the beginning of August on the line of the North Metropolitan Tramways, from Stratford Church to Manor Park, London, England, with marked success.

The Elieson gear, connecting the motor and the axle, is entirely new for the purpose. The electric machine, which bears a general resemblance to the flat Siemens or the Crompton dynamo, says *Engineering* (London), is mounted on the top of a vertical shaft, which shaft is exactly over one of the car axles, to which it is coupled by bevel wheels. It is evident that if the vertical shaft be rotated (carrying with it the motor) the car will move forwards or backwards. To effect this rotation the armature spindle is furnished at one extremity with a bevel pinion gearing into a stationary circular bevel rack, 4 feet 6 inches in diameter, attached horizontally to the car body. As soon as the armature commences to rotate its pinion travels round the rack, causing the machine to revolve on and with the vertical shaft, which, if prolonged, would pass through the center of the horizontal armature. This arrangement is somewhat difficult to follow from verbal description, our contemporary observes, and it is not easy to find any analogy to aid the comprehension of the attitude of the electric motor, "unless we compare it to a cockchafer buzzing around on the point of a pin." The difficulty of reversing the brushes on the commutator, in order to make the armature rotate in either direction, has been avoided by the device of placing two bevel wheels on the axle, one on either side of the driving pinion. Both these wheels run loose, but each is provided with a clutch by which it can be connected to the shaft. Consequently by disengaging one wheel and engaging the other, the car is made to travel either way, although the armature of the machine runs in one constant direction. These wheels are of phosphor-bronze, while the circular rack has mortise teeth made of hornbeam. The motor is mounted in a massive stirrup guided above and below, and free to move slightly on the vertical shaft, so that the play of the car springs does not affect the depth to which the teeth engage.

The car is provided with switches, ammeter, and voltmeter at each end, so that the driver has full command of the machinery whichever way the vehicle is running. The switch enables one-fourth, two-fourths, three-fourths, or the whole of the battery to be connected to the motor, while the brake acts on the wheels in the usual manner. "Thus the locomotive is under as complete control as a horse car." There are eighty cells, carried in two tiers at each side of the car. These are also the invention of Mr. Elieson, and are a compromise between the Sellon and the Planté type of batteries. Each plate is a grid, but instead of the recesses being filled with oxide of lead, there is inserted in each a spiral formed of alternate wrappings of sheet lead and asbestos paper. These spirals are "formed" by the current, and are said to withstand the jolting of the vehicle and the general wear and tear remarkably well. The total weight of the car is 6 tons, and the speed never exceeds 8 miles per hour, 6 miles being the average rate. The time has not been long enough for a very accurate demonstration of the cost of haulage, since the items of depreciation and repair can only be determined by extended trial, but the Elieson Electric company claim that after every allowance has been made the cost of drawing a tram-car (including the driver's wages) cannot possibly be more than 4d., as against 5d. with horse-flesh.



“Lovely” Discomfiture of Strikers.

As our readers are aware, striking devils have held possession of some street car drivers and conductors at Cincinnati for some little time, and an effort has been made to oust Mr. John Harris, President of the Consolidated Street Railway Company. The unpleasant work was kept a brewing, under one pretext or another, up to Nov. 24. On that date a demand was made for the discharge of Charles Standard, “a sub on the sub-list of the Clark street line” of the consolidated company, on the ground that he “aided to break up the strike on the Kerper roads.” Mr. Harris stood firm, and the mischief-makers had to try and devise some other scheme. But ultimately “the cat jumped out of the bag.” Dan Wheaton, President of Midnight Assembly, K. of L., was scheming to get into President Harris’ shoes! We need not waste time to recapitulate the base and contemptible dodges which were resorted to. Suffice it to say that on Nov. 28 the men of the assembly were “after Dan Wheaton’s scalp.” And late that night Superintendent John Harris, of the Consolidated Street Railway company, was the recipient of an ovation in the shape of a serenade, which, after the late unpleasantness, was a pleasant surprise to the gentleman. About ten o’clock, as our correspondent informs us, Messrs. Mike Casey, of the Third street line; A. W. Cattell, of the Sixth-street line; Tom Purtell, of the Clark-street line; Wm. Crowley, of Elm-street line of cars, and Receiver Enoch Kennedy, of the Eighth-street line, assembled

The Adams’ Elevated Railway.

The plans of this novel railway “in the air” have been examined by eminent engineers, whose report thereon is as follows:

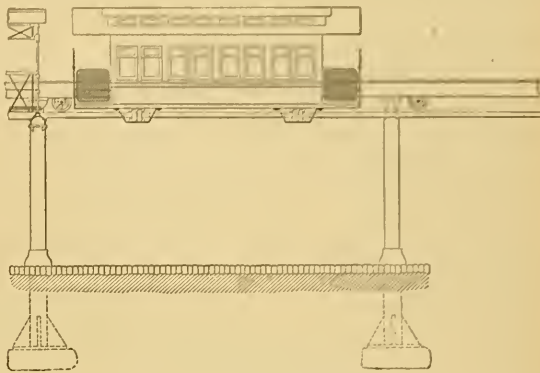

FIG. 2.—ADAMS’ ELEVATED RAILWAY.

“CHICAGO, NOVEMBER 25, 1887.

“Our opinion has been requested on the practicability and economy of ‘The Adams Single Track, Single Column Elevated Railway System’ and its adaptability to large cities.

“This railway is built of iron or steel; the girders that carry the track are longitudinal and rest on single columns which rest on solid foundations placed the required depth below the street level, to give the structure stability and rigidity against the effects of the dead and moving load, acting vertically, and longitudinally, and also against the forces acting transversely, such as wind pressure, unequal loading, centrifugal force and lateral impacts due to the movement of cars with a speed of twenty miles per hour. The railway is of single rail type. Two large swiveled paper wheels support the load and move on the rail with a flange in the centre of the tread moving in a slot of the rail. These large supporting wheels are held in position and prevented climbing the rail by smaller pilot wheels. The rail is placed inside of and considerably above the floor level of the car, making it impossible

for the car to fall in the street below, even if derailed. Below the car and attached to it are four horizontal guide

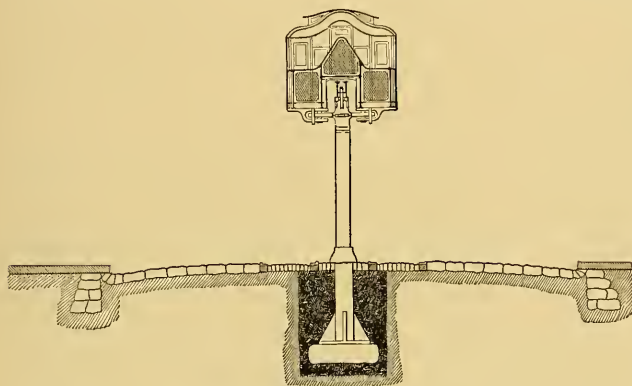

FIG. 1.—ADAMS’ ELEVATED RAILWAY.

with two hundred men of the various street-car lines at the Spring Grove avenue stables. Headed by a brass band the column marched to the residence of Mr. Harris, No. 610 State avenue. Arriving at Brighton, the party was met by a committee consisting of Messrs. Joe Epply and Joseph King, who had in charge an elegant crayon picture of Mrs. Harris, a present of the employees to Mr. Harris. Arriving at the Harris homestead, the band struck up a lively air from “Fatinitza,” and aroused Mr. Harris from his slumbers. That gentleman welcomed his visitors most heartily. Mr. Epply made a brief presentation speech. Mr. Enoch Kennedy, as spokesman for his fellow-employees, congratulated Mr. Harris upon the adjustment of all recent troubles. At the conclusion of the speeches the host invited the boys to a spread which had hurriedly been arranged, and which had the effect of keeping the boys together until a late, or rather early, hour.

The West Chicago Street Railroad Company are ready to convert their newly acquired horse car lines into cable, and may also build elevated railways—on single columns, between the present tracks.

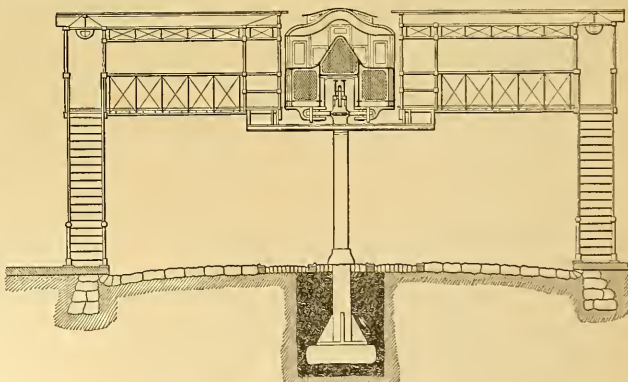

FIG. 3.—ADAMS’ ELEVATED RAILWAY.

wheels, two on each side, moving along and against a vertical face, to insure steady motion while running, and resist

the transverse forces due to wind, unequal loading, etc.

"The cars are moved by cable or electric power, the cable being placed immediately under the central rail. The cars are arranged with longitudinal seats facing outward, with sufficient room between them and the sides of the car for the passengers to get in and out conveniently. There is to be no terminus, but the cars are to move on a loop, thus making it possible to have a continuous movement of cars.

"We have carefully considered the principles involved, and have examined the plans on which it is proposed to build and operate this system, and we are of the opinion that, with some modification and further application of details, the system is both practicable, safe, economical and well adapted to the requirements of the traffic of large cities.

"SAM'L G. ARTINGSTALL, A. GOTTLIEB, E. L. CORTHELL."

The accompanying cuts will help to understand the main features of this invention—an elevated railway with a track

presenting the least possible obstruction, and standing 15 feet above the street. Fig. 1 represents an end elevation of an elevated railway system embodying the Adams' invention. Fig. 2 is a side elevation of the same. Fig. 3 is an elevation of one of the cars, together with the opposing stations. Fig. 4 is a bottom plan view of a car turning a curve, which also indicates position of seats and guide wheels. Fig. 5 is a side elevation of one of the stations, and the approaches thereto. Fig. 6 is an end view of car, showing arrangement of platform for crossing track. Fig. 7 is a top plan view of same. Fig. 8 shows in section the operator's platform (in front), and also adjoining platforms for smokers. Fig. 9 is a plan view of the same. Fig. 10 is a bottom plan view of the tracks for the guide wheels of the cars. Fig. 11 is a central longitudinal section exposing the supporting wheels with their pilots, and also the location of guide wheels. Fig. 12 is a central transverse section of one of the cars, upon the track, showing location of wheels relative to the track, and also position of the guide wheels.

Some of the other peculiarities claimed for this system are—that the structure on which the cars are to be run will be no wider than 14 inches—the tracks are to be arched at street intersections—there will be no cross structure of any description—derailment of cars, by the very principle of the system, will be practically impossible—switching and cross tracks are provided for—entrance and exit are from the rear platform only—and there are to be no conductors, but station agents.

Such a system as this would leave the streets practically unobstructed; and, being worked by cable or by electricity, there would be no puffing locomotive, nor smoke, nor cinders. The "L" roads now in use are practically the same as the regular railroads, whose ties rest on the ground, with the addition of thickly placed massive pillars on which are built more massive and untransparent structures to support the rails. It is these ugly accompaniments that make elevated railways hideous.

This Adams' system is designed to obviate all of that. And the inventor claims to have thoroughly solved the rapid transit problem, and that his system is matured to such a degree as to be fully ready for putting in practical operation.

The specifications state that "the car wheels have double treads with a flange between them projecting in the slot in the rail, whereby the car wheel is maintained on the rail, and the weight of the car is distributed on each side of the flange. And this construction of a single track and such car wheels may be readily adapted for use as a cable or electric road; the slot in the track provides the usual access for the grip to a cable necessarily running in a plane below the track. \*

\* \* \* The steering wheel is an important feature of this invention; it gives direction to and also steadies the car wheel in its forward travel, just as does the guide wheel of a bicycle; and this is true whether a car wheel is running in a straight line or in a curve, for it turns with the car wheel

because of the attachment of both to the same turn table. The effect of this directing wheel is to extend the rail bearing of the car wheel, and to destroy the natural tendency of the same to a lateral vibration or movement during its forward travel; for, being of a smaller diameter and considerably outside of a line to the

axis of the turn table, the directing wheel responds more quickly to laterally acting forces, and by a steering action forcibly maintains and directs the car wheel in a line with the rail—whether the rail be on a curve or on a straight line."

Such "rapid transit" may be secured by this new plan of elevated railway as to eclipse all other methods hitherto known. There are other so-called single track systems, but this is really the only plan, as far as we are aware, that has been pronounced practical, whereby it is proposed to run the cars on one rail. A double station may be placed at every street crossing—in business sections—and the cars

pass by every minute, and off they go at the rate of 20 or 25 miles an hour comfortably. Cars are to run continuously, according to this system, except when halting at stations to take in or let out passengers. There will be no "trains"—only single cars; starting at one side or end of a city the railway will reach the opposite side or end along one street, and then form a loop and return along a parallel street. Thus confusion will be impossible, and the "crowd" will be under the control of one person at the station entrance. Cars need not stop, if full, except where passengers want to get out; and two independent cars may be "handled" simultaneously. The entrance to a station will be on one side, and the exit on the opposite side.

Chicago is likely to have the first railway built on this system. Practical engineers declare there is nothing against it, except its newness! And they wonder such a scheme was not matured long ago. "For everything there is a time," however; and Chicago, more than any other city, is now open for an improved elevated railway.

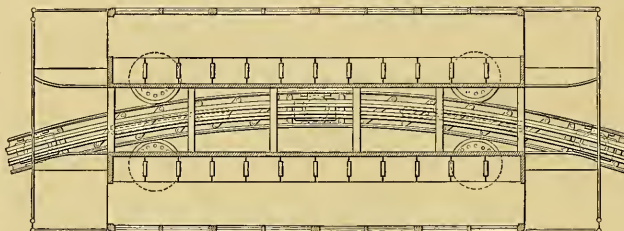

FIG. 4.—ADAMS' ELEVATED RAILWAY.

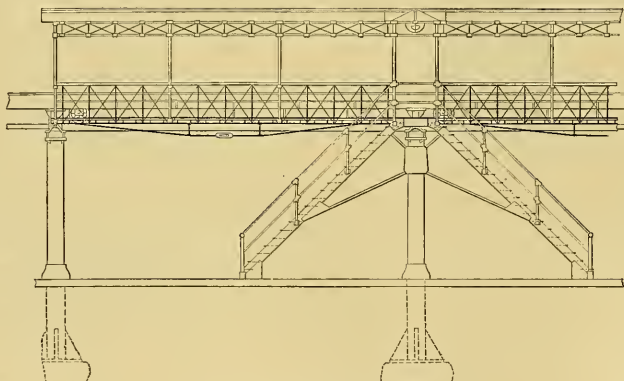

FIG. 5.—ADAMS' ELEVATED RAILWAY.



### The Ohio State Tramway Association.

The sixth annual meeting of the Ohio State Tramway Association was held November 16th, at the Arcade Hotel, Springfield, O., under the auspices of the Citizens' Street Railway company. A couple of dozen of delegates were in attendance. The past president of the Association, Mr. D. W. Stroud, was away in California. In his absence, Gen. Asa Bushnell was appointed to preside on the occasion. Secretary H. A. Everett read the minutes of the last annual meeting (held in Dayton). Letters of regret for being unable to attend were read from Mr. John Kilgour (Cincinnati), and Mr. A. C. Moss (Sandusky). Mr. C. H. Kilgour, represented the Columbia and Cincinnati Street Railway Co. Mr. Chas. Hathaway (Cleveland) arrived in the afternoon. Papers were read on—(1.) "Purchasing and disposition of horses, including their relative value with mules," by Mr. John Harris, Cincinnati; (2.) "Detection and punishment of dishonest employees," by Mr. J. B. Hanna, Cleveland; (3.) "Rules, discipline, uniforms, etc.," by Mr. A. D. Rodgers, Columbus; (4.) "Eccentricities of the members of the O. S. T. A.," by Mr. Geo. B. Kerper, of Cincinnati. The papers are to be printed and published together, in pamphlet form, and will be forwarded to all the members and others. Mr. Rodgers' paper is given on page 251.

Mr. Harris's was discussed to a considerable extent. The experience of the different members was the fact that horses on an average cost almost twice as much as mules, and also that the mules can endure on short trips more than horses; and the companies using them say that less mules die, and are sick than horses. The Springfield Street Railway company is almost the only company in Ohio, who use the mules to any

the next annual meeting of the association at Cincinnati, on the third Wednesday in November, 1888. And the following are subjects for special papers at the next meeting: (1) Steam and other powers than electricity and cable—Mr. C. B. Clegg, of Dayton; (2) Cable and horse powers—John Kilgour, of Cincinnati; (3) Electricity—A. G. Clark, of Cincinnati and Baltimore; (4) "Best present construction for road bed and buildings"—Charles Hathaway, Cleveland; (5) "Legal decisions for and against street railways and present laws in force in Ohio"—A. E. Lang, of Toledo.

Col. Geo. B. Kerper, of Cincinnati, was the chief speaker at the banquet held in the evening; he kept the company in a most merry mood; "he is an encyclopedia of humor."

The Big Six band contributed much to the happiness of the occasion.

### Swem's Automatic Switch.

"One of those present at the convention of the Ohio State Tramway Association, was a plain-dressed, intelligent-looking man with the unmistakable aspect of a westerner. He was Mr. James H. Swem, of Denver, Colorado, an inventor of considerable prominence, whose latest invention is an automatic street-car switch for cable, electric or animal power roads. The switch has come into very general use." That is the way he was described by one of the delegates on his return home; it was a cutting from some paper which he had pasted in his hat.

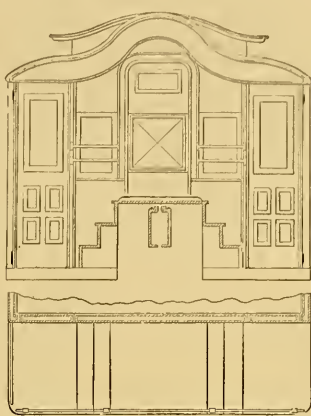

FIGS. 6 & 7.—ADAMS' ELEVATED RAILWAY.

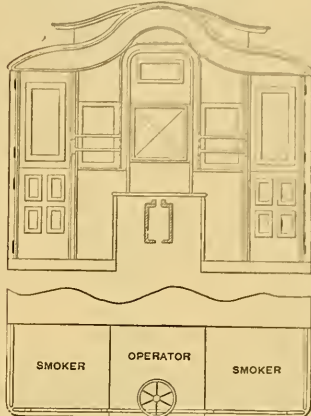

FIGS. 8 & 9.—ADAMS' ELEVATED RAILWAY.



FIG. 10.—ADAMS' ELEVATED RAILWAY.

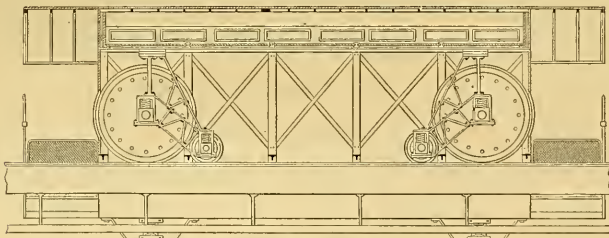

FIG. 11.—ADAMS' ELEVATED RAILWAY.

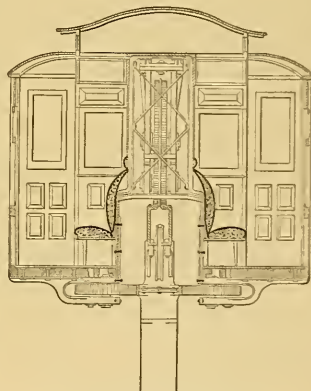

FIG. 12.—ADAMS' ELEVATED RAILWAY.

great extent, and Supt. W. H. Hanford, in giving his experience, said that in five years with 138 mules and 10 horses, five mules and two horses have died, two of the mules having to be knocked in the head on account of a leg being broken.

The following officers were elected for the current year: President—J. E. Bailey, of Toledo; Vice-President—Asa S. Bushnell, of Springfield; Treasurer—J. B. Hanna, of Cleveland (re-elected); Secretary—H. A. Everett, of Cleveland (re-elected); Executive committee—John Kilgour, of Cincinnati, with the above officers. It was decided to hold

### Ohio Tramway Meeting Notes.

Mayor Kelly spoke words of welcome. Gen. Bushnell was an admirable toastmaster. Col. Kerper's "Eccentricities" were immense. Host Munger (formerly of the Matteson and Clifton houses, Chicago) provided a splendid banquet—long to be remembered. Supt. John Harris appreciated a "sympathy motion." Chas. Hathaway's "Conductor's Pedigree" was very interesting.

"Compliments of the STREET RAILWAY GAZETTE" was inscribed on a large etching of himself, presented to the Hon. G. B. Kerper, by Gen. Bushnell, at the close of the banquet.

Secretary H. A. Everett's efficient services are highly appreciated.

The Fleming Manufacturing Co., of Fort Wayne, Ind., had on exhibition both a "Boss" and "Walkaway," scrapers-plows, its two able representatives booked several orders for the same.

Both S. M. Carpenter, proprietor of the Fulton foundry, Cleveland, O., and his private secretary, C. J. Langdon, attended the convention and received a sincere welcome from all the delegates, to whom they are so well and favorably known.

Sheldon Beckwith was on deck, as usual, hustling up matters for the Supply Co., of which he is the proprietor.

J. M. Swem, of Denver, had one of his automatic switches in position, which attracted no little attention, and of which nothing but good words were spoken by the visiting delegates.

Mr. Rogers, of Columbus, favors electricity or cable,—in fact, anything better than animal traction—and will probably adopt one or the other ere long. He inclines to cable, provided the cost of installation can be cut down to about \$10,000 to \$15,000 per mile.

One of the cleverest young cable engineers in the country has about perfected a system of a shallow conduit for cabling, which will perhaps solve the problem of cheaper installation.

### The Daft Electric Railways.

The Hon. Geo. B. Kerper, president of the Mt. Adams and Eden Park Inclined R'y Co., Cincinnati, made application to the Board of Public Affairs, Nov. 26, for permission to erect poles for an electric railway on the Oak street branch of his lines. The ordinance provides for the running of the cars by cable, electricity, or any other motive power, and it is Mr. Kerper's desire to avail himself of all the provisions. City Solicitor Horstman, to whom the question was referred as a matter of course, has reported that "the construction and operation of all lines of the Kerper Cable Road may be by cable, electricity, or any other system of motive power that may hereafter come into general use." His opinion is that it is the duty of the Board of Public Affairs to examine into the merits of the Daft system, with a view of ascertaining whether it meets all the requirements for public convenience and safety, and if so, to approve it as the general plan for use.

In a letter to us Nov. 30, in response to an inquiry, Mr. Kerper says: "We have adopted, on our Oak street branch, the Daft electric motors. Their last plant, at Mansfield, Ohio, is as complete and satisfactory as any I have yet seen, and is worth looking at."

On our way to the Street Railway Convention, at Philadelphia, Oct. 17, we met a prominent citizen of Mansfield on the train, who spoke very highly of their electric road, from the general public standpoint. Subsequently we wrote to the managers of the road for particulars. Mr. C. E. McBride, secretary of the Mansfield Electric R'y Co., wrote October 31st, saying:

"We would have been very much pleased to have seen you in Mansfield, and to have passed you over our road.

"We have the overhead system of electric road, operated by motors known as the Daft system. We have  $4\frac{1}{2}$  miles of track, and cars are now being run over the entire line daily. The grade on the Main street line is very heavy. Leaving the depot we have to climb a hill with a grade of seven feet to the hundred until we reach the public square. After leaving the public square we ascend a hill with a grade of eight feet to the hundred, to reach the cemetery. The cars, loaded with 60 to 70 people, ascend and descend these hills with those grades under perfect control. The cars in going up-hill run about  $4\frac{1}{2}$  miles per hour; stop and start at any place on the hill, when loaded with from 60

to 70 people. We are operating at present five cars. The cars are each supplied with three incandescent burners; the power that propels the cars also furnishing light for them. The people who at first found some objection to the overhead wires, and to the poles, are now satisfied because, as they say, our little city has the finest system of electric road in operation anywhere."

### CORRESPONDENCE.

#### The Concord Eight-Wheel Horse Cars.

Superintendent's Office, Concord Horse Railroad.

CONCORD, N. H., Oct. 31, 1887.

To the Editor of the STREET RAILWAY GAZETTE:

Dear Sir: In the current number of the GAZETTE (November) your report of my speech anent the use of eight-wheel street cars, at the Philadelphia convention, is not quite correct. I stood unwittingly with my back towards the reporters' table (forgetting for the moment the importance of the press) and so my remarks have not been fully reported in any paper. The GAZETTE (which I like better and better every time) has by far the best report; and as the subject I spoke about is of general interest, I wish you would make the following corrections:

I said I had in operation ten eight-wheel horse cars, and that I did not use small wheels of from 16 to 24 inches, but 30-inch wheels. Then in the second paragraph of your report of my remarks, you represent me as saying that I "make use of a strong center-pin, so that the truck would not swing in turning a curve." Now what I did say was that we used a strong center-pin, so the trucks would curve easily. And in reply to Mr. Henry, of Missouri, I said that the car step is 14 inches from the ground—not that the body of the car is raised about 14 inches higher than it was before.

Yours, etc.,

MOSES HUMPHREY.

#### The Eight-Wheel Electric Car.

PHILADELPHIA, Pa., Nov. 12, 1887.

In my letter of Oct. 17th, referring to the Wharton electric car exhibition, I was wrongly informed as to the length of the yard track. It is about 1,000 feet long, describing an irregular rectangle, with curved corners, and one end having a 5.7 per cent grade.

The eight-wheel car is propelled by two of the Reckenzaun motors, each weighing about 500 pounds, usually developing about ten-horse power each, the maximum being 15 h. p. It recently ran 45 miles from one charging of batteries, and during one of the hours ran 15 miles. The car seats about 36 people.

Truly,

A. R. REGER.

P. S. The battery consists of over 100 cells, weighing about two tons.

#### The Reckenzaun Motors.

PHILADELPHIA, Nov. 14, 1887.

Our eight-wheel car has been running now for some time with great success, in fact it ran all right within an hour after the members of the association left our works on October 21st. Some days ago it ran forty-five miles without recharging, twelve miles or more of which were accomplished in one hour. The distance was run on the track around our yard, and considering that at least one-half of the whole distance consisted of sharp curves and grades, it was a remarkable performance, and goes far ahead of the record of any other storage battery in the world. Thinking you would be interested in this, I let you know of it. The efficiency of the Reckenzaun motors over the Sprague motors is very marked. This not only gives us greater speed and power, but reduces the cost of electricity in running expenses. The weight of the Reckenzaun motor, per horse-power, is only about one-third of that of the Sprague motor, and about one-sixth of that of the VanDepeole motor.

Yours truly,

WM. WHARTON, JR.



### Irish's Sealed Conduit Electric Railway.

Our electrical contemporary, the *Western Electrician*, in its issue of Dec. 17th, contains an illustrated description of an important device for the better operation of electric railways with a conduit. Overhead wires are unnecessary, and an underneath conduit is securely sealed. Mr. W. E. Irish is the inventor. The conduit represented in Figs. 1 and 2 is simply an elastic and water-tight tube of soft rubber, containing within a continuous bare conductor to which contact may be made at any point within the tube throughout its whole length. Secured to the outside and uppersurface of this elastic pipe are short rail pieces, flanged at their sides and breaking contact with each other. These rails are level with the surface of the roadway and are connected by means of screws passed through the rubber conduit

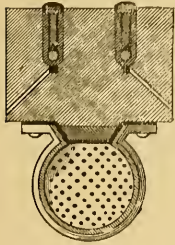

FIG. 1.—IRISH'S SEALED CONDUIT.

to sectional contact pieces within the pipe, of the same length as the rail or surface sections. These contact pieces are also insulated by space and the rubber from each other. Screws metallically connect in pairs the surface rail sections

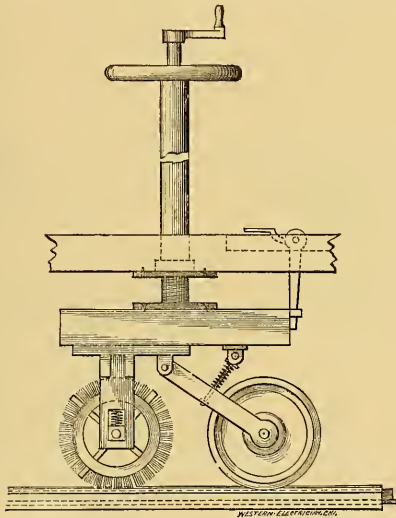

FIG. 3.—IRISH'S SEALED CONDUIT ELECTRIC RAILWAY.

outside, to the sectional contact pieces within the conduit. The flexible pipe fitted as described is placed in a suitable channel, formed in a line of timbers specially prepared, or in stone or metal troughs, placed in the centre of the track between the ordinary traffic rails and flush with the surface of the road bed. Two such conduits are placed in the same

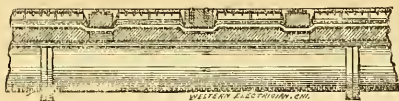

FIG. 5.—IRISH'S SEALED CONDUIT ELECTRIC RAILWAY.

line of timbers, in separate troughs, one tube carrying the outgoing, and the other the return lead or conductor. It will, of course be understood that the main conductors or leads are connected to suitable stationary generators at some point near the road. The main leads in the bottom of the tubes are coupled in sections in suitable lengths by means of a variable expansion joint which will allow of their ex-

pansion or contraction under different temperatures without in any appreciable degree altering or affecting the electrical resistance. A sleeve is placed over the ends of the conductors where they meet, inside of which is a spiral spring which presses against the ends. These springs are compressed on the expansion of the conductors and elongated when the

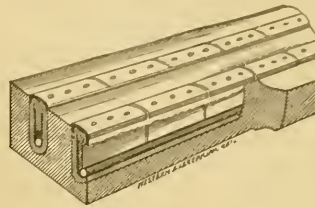

FIG. 2.—IRISH'S SEALED CONDUIT.

conductors contract, but at all times they make effective contact with the conductors and with the sleeve, as they offer less resistance than is offered by the same length of conductor. The narrow contact wheel, Figs. 3 and 4, carried under the car near its

centre, presses upon the sectional rails as it arrives upon them, causing the sides of the elastic tube to yield until the contact pieces within the tube make contact with the main lead closing the circuit through the motor. When the pressure of the contact wheel is removed from a section by being carried forward, the sides of the tube will again open out or regain their former position, and lift the sectional contact piece out of contact with the main lead. The contact wheel and the track cleaner are secured to the same frame or turn-table, which is arranged to be reversed upon the car on its return journey or according to the direction of its travel. The frame may be raised or lowered according as the wheel is to be thrown into or out of contact with the rails. In front of the contact wheel and supported on the same frame is a combined brush and scraper, designed to clear the exposed sectional rails of dirt, snow and other obstructions so that good contact may be made with the rails.

FIG. 4.—IRISH'S SEALED CONDUIT.

Fig. 5 illustrates a method of crossing a railroad track. It will be seen that it is simply necessary to carry the elastic conduits inclosing the leads beneath the cross rails, as shown, and then bring them up again between the rails until the

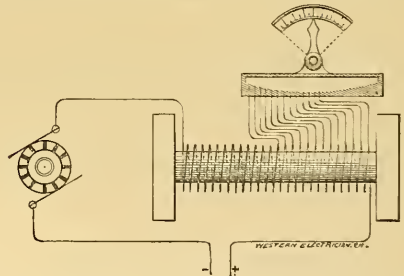

FIG. 6.—IRISH'S SEALED CONDUIT ELECTRIC RAILWAY.

other rail is reached when the conduits are again dipped. This enables contact to be made with the sectional rails between the tracks of a railroad, crossing the system, without material break in the continuity of the circuit. In case a drawbridge or the like is to be crossed with the system,

a second conductor, as a shunt in the main conductor, is run overhead or underground or submerged, as found most convenient. The conduit proper crossing the bridge as usual, but having spring contacts at each end of the bridge for connecting the mains when the bridge is open to car traffic.

Under the timbers carrying the railroad conduits a second conduit is secured—shown in Figs. 1 and 5—consisting of a cylindrical iron tube having a V-shaped opening on top throughout its entire length, and lateral flanges by which it is bolted to the timbers. In this conduit, telephone, telegraph, and electric light wires may be placed—and that independently of the railway conduit.

Fig. 6 is an automatic regulator. The tube is resting in a horizontal plane with a body of mercury in the centre. The series of wires from the motor extend into the tube, those covered by the mercury being cut out of circuit; and the electrical energy is regulated to suit various grades.

placed at the exhibition of the Massachusetts Charitable Mechanic Association, Boston, where it received more than ordinary investigation and commendation. This brake was awarded letters patent March 11th, 1884. The patentee, E. E. Baker, of Cambridgeport, Mass., claims to have introduced improvements on the old forms of street car brakes. From the following description and on reference to the engraving the arrangement of the mechanism will be understood. A thrust lever, somewhat similar to a locomotive reversing lever, is used instead of a crank; the movement of this lever is very slight, thereby giving the driver instant, positive, and at the same time, easy control over the brakes. The brake will, in consequence of this short movement of the lever and immediate application, stop a car in the least possible distance,—a feature which will in many cases prevent accidents, and is a desideratum in case of an accident.

The brake is double acting; the movement of either

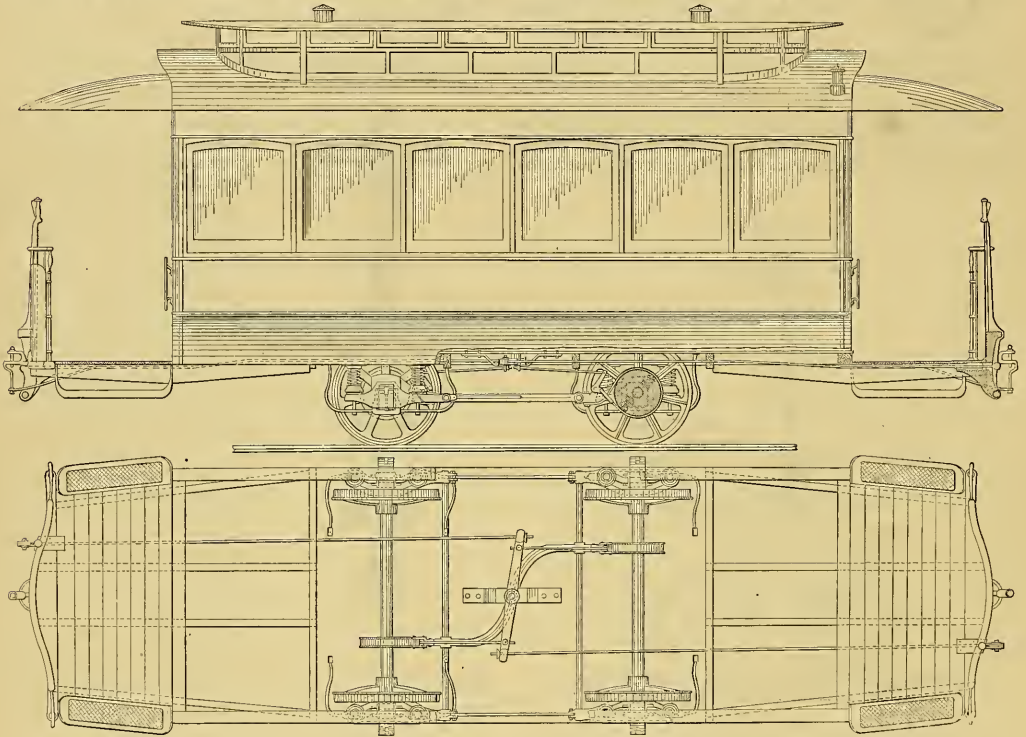

THE E. E. BAKER BRAKE.

The motor is supported under the floor of the car. It may be inspected and any portion easily renewed from the inside of the car. The armature coils are inclosed within the pole pieces in such manner as to make nearly the whole of the armature wire active. Two armatures are carried on the same shaft, the shaft being prolonged on both sides to carry the driving wheels, which are situated midway between the car wheels on each side, the power being transmitted by connecting rods working eccentrically.

### The E. E. Baker Brake.

The accompanying engraving, taken from a construction drawing, made to scale, shows a new form of brake more especially designed for street cars, but applicable to any kind of railway car,—steam, cable or electric. There are entirely new features in arrangement and construction that deserve careful attention from all interested in railway plant and railway appliances. A very complete and beautifully constructed "working" model of a car with this brake was

thrust lever applies both brakes simultaneously, yet the levers are independent and can both be applied at the same time if desired. In place of four brake shoes grinding on the tires and flanges of wheels, bands around friction discs on each axle are used. Where the mechanism is such, as in electric motors, that there is no space on the axles for friction discs, the bands would be changed to extra flanges on the inside or outside of the wheels. It is claimed that these bands are more economical in cost and more durable than brake shoes. It is safe, says the inventor, to warrant them for at least five years. In this case there being no wear on wheels excepting that from friction on the rails, all flattening of the wheels is avoided, the result being, that a yearly saving is effected, equal, nearly, to the first cost of the brakes. Another advantage claimed for this brake, is that it prevents wearing the boxes in oblong form (pressing the wheels together or apart by the brake shoes bearing on the wheels); the bands are tightened and held until released, and they are so placed that the resistance is the greatest on the rear discs, thus causing the hind wheels to stop first.



### Improved Device for Coupling and Uncoupling Street Cars.

The accompanying drawing represents a new device for coupling and uncoupling street cars, taken from a summer car (No. 139) belonging to the Cambridge street railroad between Boston and Cambridge.

The present usual method, with its chains, hooks, etc., for coupling and uncoupling is familiar alike to officials and passengers. The drawing shows what appears to be the simplest, easiest and most inexpensive way of doing this, and the device is well worthy the attention of car manufacturers and railroad companies.

The drawing is self-explanatory. The coupling pin, *I*, it will be observed, never leaves the draw-bar, *D*; it is always in place, ready to drop into its bearings, and when pulled up and slightly turned is prevented from shaking back again by the spline, *G*, coming in contact with the small stop or check pin, *H*, shown in sectional plan at *G*.

The drawing shows the vertical rod with the coupling pin, *I*, drawn up; in this position, the draw-bar, *D*, is ready to receive the other coupling link attached to the horse gear or to another car if two or more cars are to be drawn by an electric or steam motor. When the link enters the draw-bar, *D*, the handle, *F*, is slightly turned, the spline, *G*, drops into its slot or key-way, at *J*, the coupling pin passes through the draw-bar, *D*, and the coupling is complete, done by the driver without exertion or trouble, with the use of one hand.

Should an instantaneous or sudden uncoupling be necessary (and it is very frequently so) the driver has only to seize the handle, *F*, pull up the vertical rod (with coupling pin, *I*, at lower end) and the detachment is quick and positive. The small steady pin, *H*, prevents the spline, *G*, working round opposite its keyway or slot, and, of course, also prevents the coupling pin dropping in when it should not.

Further information may be obtained on addressing Mr. Sargent, agent, 7 Kilby St., Boston, Mass.

### Jones' Street Indicator and Calendar.

"A very simple, cheap, durable and easily operated street indicator and calendar" has been invented by Mr. F. C. Jones, Mill Haven, La. The entire machine, he thinks, can be manufactured for \$5.00. It will show each street in advance as the car proceeds. The patentee says he has no drawing, having handed that "and everything" over to a patent agency, whose address he furnished, and to whom he wrote for further particulars, in accordance with the inventor's instructions. But the "patent agency" has not deigned to notice the request, and thus we are unable to comply with Mr. Jones's desire by properly introducing his invention to our readers.

### A New Cable Railway System.

Another plan of propelling cars by means of an endless rope has been invented by Mr. Eugene C. McLaughlin, of Minneapolis, Minn., which he describes as follows:

"The conduit in which runs the cable is composed simply of two I rails spiked down to the ties, and with a 3/4-inch slot in the top through which runs the grip. The cable runs on lateral wheels or sheaves on either side, which are placed about thirty feet apart and run between the outer rail and the conduit. In the old system the sheaves run vertically, thereby taking up far more space and necessitating larger excavations. The channel irons or T rails in the conduit are made firm by rods running to the outer rails. These are the principal features of this surprisingly simple system. The grip is the same as heretofore used, only smaller and lighter. The advantages over the old system are very evident. First, the expense of laying the new conduit will be less than \$25,000 a mile, while the old one costs \$100,000 and over. Streets need not be torn up so long or so badly, as the simplicity of the system permits of rapid work. Cable lines as at present constructed can only be laid on streets in which sewers have been constructed, as a complete drainage of the big excavation is essential. Mr. McLaughlin's cable can be advantageously laid on any street. The method of cleaning the conduit is novel and effective. A wire brush or broom fitted to the cavity may be attached either to the grip or in some other way to the car. At convenient intervals small pits are constructed, and as the brush runs along the conduit it sweeps all dirt, snow and ice into the pits, whence it is gathered up whenever necessary. The water can be led off into cesspools or sewers very easily."

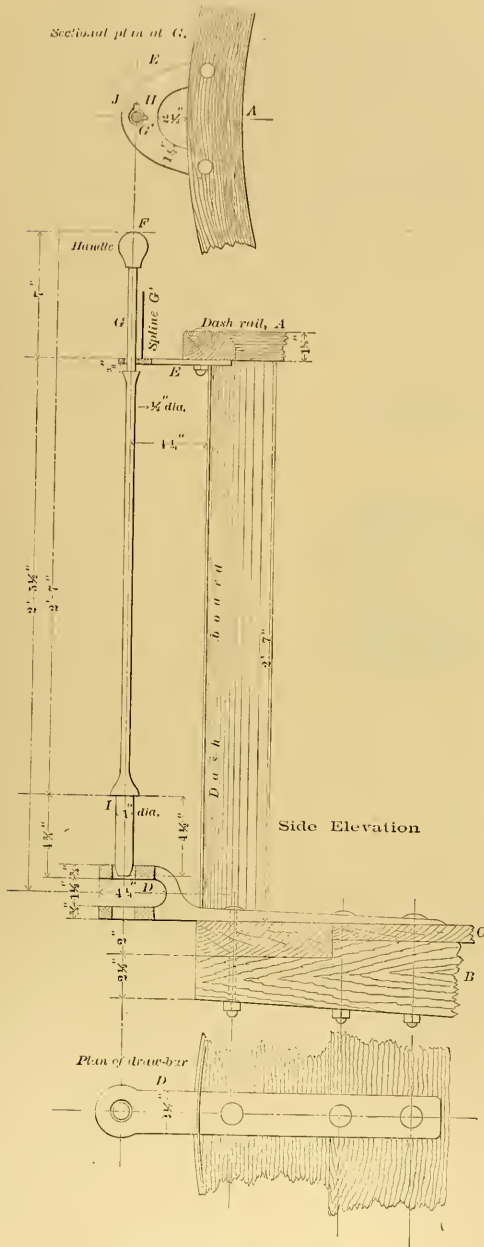

IMPROVED COUPLING DEVICE.

- |                               |  |
|-------------------------------|--|
| <i>A</i> , dash rail.         | <i>G</i> , vertical rod.                                   |
| <i>B</i> , platform sill.     | <i>G</i> , spline let in rod <i>G</i> .                    |
| <i>C</i> , flooring.          | <i>H</i> , small steady pin.                               |
| <i>D</i> , draw-bar.          | <i>I</i> , coupling pin.                                   |
| <i>E</i> , guide bracket.     | <i>J</i> , key-way or slot cut in guide bracket <i>E</i> . |
| <i>F</i> , brass handle knob. |  |

### A New Grip for Cable-Railways.

A new system of cable-gripping has been patented by Mr. W. F. Wiechardt (Wiechardt & Mingle), Philadelphia. The accompanying cuts show sections of the usual slotted conduit, the cable, and side and end views of the grip. The grip shank has the lower end bent around to form bearings for the lower roller journal shafts, an upper bent plate is bolted to the shank in line with the bent end to form bearings for the shafts of the top rollers. The rollers are grooved and are concentric with or have like bearings upon their journals, but the journals have eccentrically arranged shafts with bearings in the sides of the grip-shank, so that the rollers, when rotated upon their journals, have a concentric motion, but when moved by the eccentric shafts have a movement to and from the cable. The shafts of the lower rollers are so placed that they will always be in gripping position with the cable, so that they will also act to support the cable when not in use for gripping rollers. But the lower rollers can be released also, and the whole grip removed so as to pass over a crossing cable when necessary.

By means of the devices attached to the journal eccentric shafts, and acting in conjunction with mechanism located within the conduit adjacent to crossing lines, or to other points along the line of way, the rollers are automatically released from the cable to allow it to move laterally out from beneath the gripping rollers as the grip approaches a crossing line or another point where it is necessary to release the cable from the grip, and there is a provision for correspondingly re-engaging the rollers with the cable after the grip has passed the crossing line.

"It is evident," say the patentees, "that when the rollers are gripped upon the cable they rotate upon to an extent that is sufficient to pinch it, and as their rotation is concentric with or on their journals, the pinching of the cable by the rollers does not injuriously wear it; and when the rollers are released from gripping contact with it the latter slips through the rollers, and as they then rotate undue wear on the cable is avoided. In the construction of this grip the upper wheels do the gripping and releasing, and revolve around their axis when not tightly closed, and permit the car to travel at a less speed than that of the cable, at the will of the gripman."

### The Rischmuller Cable-Grip, &c.

A cable railway-grip and air-brake, designed to prevent accidents on cable-roads, has just been invented and patented by George Rischmuller, of San Francisco. Unlike that of what is known as the Hallidie Cable Railway, this grip is so constructed that a dummy is unnecessary, the car being operated by means of two levers, which move sideways. These are placed on the forward platform. Beneath the car are placed several air-chambers, which are connected by piston-rods with the levers. When the car is started the piston-rod forces the air in the main air-cylinder, through compression, into two cylindrical reservoirs placed on either side of the main air-tube. These two reservoirs are also connected. The air, which is preserved in these two cells, is used in applying the brake or in case of accident. The cable is held as nearly level as possible by a series of pulleys supported at short intervals by weighted angle-levers, which are fulcrumed below the cable. There is no friction to the cable, owing to the presence at every ten or fifteen feet of a clutch enlargement fastened to the cable. This catches the grip and carries the car along. Under this system a shallow cable channel, eleven inches deep and five inches wide, is only needed.

In addition to these features, the most important point of the invention consists of an automatic brake. Extending in front of the car about four feet is a movable fang, which slides backward when anything falls upon or obstructs its course. The reversed motion of the fang loosens the grip and operates the air-brake, stopping the car immediately.

### Wm. D. Smith's Universal RR.

An inventor, whose genius has hitherto "blushed unseen," recently called upon the famous Charles T. Yerkes, at the offices of the North Chicago Street RR. Co., and told the president that he had matured (in his head) such a railway scheme as would revolutionize, etc. Not only is the scheme a splendid one, as it appears in the inventor's mental camera, but it is made visible in the shape of a model. The inventor informed Mr. Yerkes that he had such a model, and also mentioned, incidentally as it were, that if the model was seen the cable system would be forthwith abandoned: it was with a view of heading off the folly of laying the cable that the inventor condescended to visit President Yerkes and prophesy against the cumbersome cable system. This was when the operations now in the main completed were being commenced. Unfortunately the great street railway manager merely told the inventor that he might call with his model—he did not express any desire to see it, but gave a kind of on sufferance permission, saying, "You may bring your model, if you like." This was so discouraging that nothing more was heard of the model, and the inventor's whereabouts remained unknown until the residents on the West Side of Chicago held public meetings to discuss the question of increased facilities for rapid transit in that part of the rapidly growing city. Then a postal card was sent to some of the leading citizens, stating that a model of the coming railroad system could be seen at room 329, No. 84 Market street, Chicago.

Subsequently our way was wended

thither. And there we discovered the inventor, and had the pleasure of looking at his model of the car and railway that is going to beat the clumsy things now in vogue out of time altogether.

The model consists of a miniature railroad car, bought at some toy shop, on the side of which is prominently painted Wm. D. SMITH'S UNIVERSAL RR., and two pieces of rail are fixed in a light iron framework—one rail being above the car and the other rail below it. The car runs on two wheels, one forward and one aft, running vertically on the bottom single rail, while a couple of small guard wheels run similarly against the rail overhead called the guide rail. The car is thus so fixed that it can not jump the track—it is kept firmly on the rail, with proper flanges on the two carrying wheels. One might have supposed that flanges (large enough) on the guard wheels might have been sufficient to hold the car in position, but instead of that there are two pairs of guide wheels, one pair on the fore part and one pair on the other part of the car, to help the guard wheels. The latter, as already said, run against the overhead or guide rail, in order to keep the carrying wheels on the bottom rail. The two pairs of guide wheels run horizontally on the sides of the guide rail, whereby the car is kept from falling. Thereby, the inventor claims, perfect safety is assured. And, although eight wheels are attached to each car, it is claimed that the maximum of momentum combined with the minimum of friction, together with the most perfect adhesion, may thus be secured.

The brain of Inventor Smith is full of the scheme: he can see (in immediate prospect), not only the streets of all cities covered with his UNIVERSAL railways, but such rapidity and "absolute security" can be attained with the

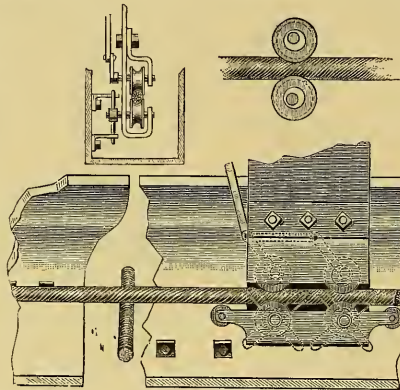



system that the UNIVERSAL is destined to supersede all our present great railroads; railroad bridges will be no longer necessary, for a couple of rails stretched across any chasm will be sufficient to carry the cars with flying speed, et cætera, et cætera.

When the inventor's enthusiasm was intensest, and the car sent backward and forward rapidly, the solder at one end of the carrying rail gave way, and down went rail, car and all its wheels. But, nothing daunted, he explained at once that that was only a cheap model, the whole thing costing not quite six dollars, and merely a means of illustrating what the scheme is in the inventor's mind. It remains with capitalists to afford means of practical developments. *Res angusta domi.*

## Construction, Equipment and Maintenance of American Street Railways

BY AUGUSTINE W. WRIGHT.

*Continued from page 238.*

IN CONCLUSION.

The aggregate yearly income accruing from the transportation of passengers upon the street railways of this country is a sum so vast that it cannot be comprehended by the human intellect; but great as it is, 'tis collected in dribbles—five cents at a time! Truly an emphatic example that we should

"Think naught a trifle, though it mean appear:  
Small sands, the mountains; moments make the year,  
And trifles—Life."

The collection of fares, the employment of honest men, the safeguards put forth to deter the weak from becoming dishonest and to detect those who steal are matters of such great moment that they are discussed at each succeeding convention of the American Street Railway Association.

To secure a satisfactory conductor the company must pay a fair salary.

Adam Smith wrote in his "Wealth of Nations," "The proper performance of every service seems to require that its pay or recompense should be as exactly as possible proportioned to the nature of the service. If any service is very much underpaid it is apt to suffer by the meanness and incapacity of the greater part of those who are employed in it. If it is very much overpaid it is apt to suffer, perhaps still more by their idleness and negligence."

Each company will find it to be the part of wisdom to treat its employees fairly and justly, as recommended by the above committee. If the management of a road shall have established a reputation for harsh and unfair treatment of employees, good men will be loth to enter its service and strikes will be far more apt to occur upon slight provocation.

Allow the men time for meals, and do not require an unreasonable number of hours' service. Above all, when the services of a good, honest man have been secured, be not hasty in discharging him.

Upon the question of honesty of mankind in general, I believe the world has changed, and for the better, since Shakespeare wrote, "Ay, sir; to be honest, as this world goes, is to be one man picked out of ten thousand."

Honesty is a matter of education, not natural to mankind. Other things being equal, the man who as a child was taught to tell the truth, to be honest and true, to do unto others as he would they should do unto him, is not likely to steal.

Montaigne, that profound student of human nature, wrote three hundred years ago:

"Plato reprehending a boy for playing at some childish game: 'Thou reprovest me,' said the boy, 'for a very little thing.' 'Custom,' replied Plato, 'is no little thing.'

Our greatest vices derive their first propension from our more tender infancy; our principal education depends upon the nurse.

In employing a conductor, therefore, the superintendent should, so far as possible, ascertain something of his family and past life. Heredity and environment have a weighty influence in the formation of each human character.

Where many men are employed this information can only be obtained through "references," for—"Men can be judged by those who know them, not only as they are represented by those who know them," wrote the grave Samuel Johnson. Yet an experienced observer can frequently judge accurately of the character of an applicant by a careful scrutiny of his countenance.

"At a glance thou judgest well; years could add little to thy knowledge,  
When honesty's open brow or the weazel face of cunning is before thee."

Having made your selection and employed an "honest man," lead him not into temptation!" "Throw safeguards about, so that if he wavers he may not fall. The experienced superintendent realizes the multitude of temptations that beset their conductors upon every hand. A little yeast leavens the bread! One dishonest employee debauches many.

Much more might well be written upon the important subject of street railways, but the organization of the American Street Railway Association, inaugurated by H. H. Littell and others, with its annual meeting, valuable papers by practical men, founded on experience gained by years of active service, the discussion that always follows the reading of said papers, and the publication of these proceedings fill a long felt want. I trust that the association will continue to grow as rapidly as in the past, until it shall include every street railroad among its members.

Two papers are now devoted exclusively to the street railroad interest, and the amount of available information is, therefore, now far greater than ever before.

## Cable Railways in Great Britain.

Mr. A. S. Hallidie, the inventor of the wire-rope system of propelling street cars, honored us with a call Nov. 5th, on his return to San Francisco, from across the water, where he visited the managers of the cable tramways in course of construction over there, as announced in the JUNE GAZETTE. Two and a half miles of cable tramway is about completed at Birmingham, England, and a mile and three-quarters, double track, will soon be finished at Edinburgh, Scotland; while the city of London and Southward Subway, (which we fully described in a recent issue,) is progressing satisfactorily. The latter, however, is not expected to be finished and in operation before about the end of next year.

## A Steam Omnibus.

Experiments have been made in Dresden with a new steam omnibus, and an exchange says the results were very satisfactory. The 'bus, which is the invention of a gentleman named Michaelis, of Chemnitz, and the banker, Emil Quellmalz, of Dresden, does not run on rails, but has its wheels excellently adapted to easy running on the streets. It is fitted with a perpendicular boiler and a compound engine, and runs on springs. The motive power of the engine is applied to the two hind wheels of the 'bus, which stands about one meter high, while movement is communicated to the two somewhat lower front wheels by means of cogs. The new arrangement has also been employed in the carrying of heavy loads, and with equally satisfactory results. The omnibus will be able to seat twenty persons inside, and will have standing room at each end for six persons.

THE man who crosses his legs in the horse cars deserves the attention of the authorities—"at least the social authorities," says a correspondent. Ladies hold back their dresses and try to walk around without having to wipe muddy boots with their skirts, while the men who can step high enough walk over the cross-legs.

NORTH Chicago is to have its thirteen miles of new cable railways in operation by the 1st of January; or else Mr. Yerkes will know the reason why. The "opening" is looked forward to with great interest.

The  
**Street Railway**  
Gazette.

Annual Subscription (Including Postage).		Per Copy.
United States, Canada.....	\$2.00.	20c.
Great Britain, Ireland, India, Australia.....	10s.	11d.
Germany.....	9mk. 75 pf.	89pf.
France, Belgium, Switzerland.....	11fr. 85c.	Fr 1.10.
Spain.....	11ps. 95c.	Ps 1.10.
Austria, Holland.....	5fl. 74c.	53c.
Italy.....	12 lire.	1½ ltra.
Venezuela.....	12 bolivar.	1¼ bol.
Mexico.....	\$2.96.	30c.

*Ann. Subs. in Argentine Republic, 2½ peso; Brazil, 4 milreis; Turkey, 54 plasters*

Registered Cable Address—TRAM, CHICAGO.

PUBLISHERS:

THE WRIGHT-MONROE COMPANY.

P. G. Monroe, - - - - - President.  
E. V. Cavell, - - - - - Secretary.  
S. L. K. Monroe, - - - - - Treasurer.

GENERAL OFFICES:

CHICAGO, - - - - - NEW YORK, - - - - - BOSTON.  
CHICAGO:  
9 LAKESIDE BUILDING.  
William Hughes, - - - - - Editor.  
Edward J. Lawless, - - - - - Associate Editor.  
NEW YORK:  
181 BROADWAY.  
H. D. Cozens, - - - - - Manager.  
BOSTON:  
19 TREMONT ROW.  
G. W. Paine, - - - - - Manager.  
T. P. Pemberton, - - - - - Resident Editor.

BRANCH OFFICES:

ATLANTA, Ga.: Chamber of Commerce Bldg., Wm. Minnigerode, Mgr.  
SAN FRANCISCO, Cal; 1222 Bush St.,—G. W. Fairchild, Manager.  
CANADIAN AGENCY:  
TORONTO: 53 Magill Street,—Thomas Henry, Manager.

INVENTORS are extremely busy, and several have their eyes fixed on Chicago. We have information concerning three important schemes, which the inventors declare will be of the greatest value to this great and rapidly growing city. They have not yet received their caveats, and we are not at liberty to publish particulars, but details are promised for the January GAZETTE.

THE disadvantage from the weight of the cells is largely obviated by using lighter cells for street-car traction than for electric lighting. It is found that the cells can be used advantageously from three to six hours at a time without recharging, while the time occupied in replacing discharged cells does not exceed three minutes. That is what is claimed in favor of storage batteries.

THE death of Sir Wm. McArthur, once Lord Mayor of London, while riding in an underground train, has been mentioned as an argument against the proposed Arcade railway in Chicago. But death often happens on surface street cars, and also on the elevated roads. Patrick Kenna, of 184 West Taylor street, Chicago, died of heart disease on the afternoon of December 2, in a Twelfth street car near Ashland Ave.

WHARTON'S new electric eight-wheeler is working admirably, it appears. Mr. Reger writes, Dec. 10th, saying: "It is propelled by two Reckenzaun motors, with 116 cells, 23 C; with one change of batteries, it ran, one day this week, 63 miles and 211 feet in eight hours—over five miles were grades of 5 <sup>3</sup>/<sub>10</sub> per cent., and there were 331 curves of 33 feet radius, and 662 curves of 50 feet radius."

JACOB SHARP, New York, is out on bail, and is to have a new trial—if he lives long enough.

THE Manhattan Elevated Ry. Co. will sell, after Jan. 1, \$2,000,000 new consolidated 5 per cent bonds at a premium, being part of a blanket mortgage of about \$15,000,000.

THE Kansas City Electric Ry. Co. (Henry system) made an assignment, Dec. 12, to Evan A. Fursell for the benefit of its creditors. Assets valued at \$10,000; debts unknown.

HONESTY is not rewarded in Boston, even with gratitude, if the conduct of a "lady" of the Hub which has been reported to us may be taken as a criterion. She lost her pocketbook in a South Boston car, containing "valuable papers that could not be replaced;" she called at President Hersey's office, who handed her the lost valuables intact. Instead of thanking him, she requested a free ticket for having the trouble to call!

TEMPTATION and ruin have deprived the President of the Lima (O.) Electric Motor Railway Co. (Mr. B. C. Faurot), who is also President of the Lima National Bank, of his stenographer and type writer. It is the old story. John Reston was a smart young man, he was trusted (as private secretary) with all the office books, cheque forms, etc., and discovered to be a forger of several cheques which he used to make good his losses at the "gambling hells" which he frequented. "My first crime" said he, "was when I was invited into the Cafe gambling-house, run by a man named Carsey, where, by an investment of \$1, I was permitted to win \$25, but was afterward fleeced out of large sums." Reston's forgeries will amount to several hundred dollars, but out of sympathy for his sick and invalid mother, Mr. Faurot will not prosecute him.

Inventor and Mechanic J. W. Adams.

THE Adams single track elevated railway system, described in this issue of the GAZETTE, is the invention of a gentleman, well and favorably known in the manufacturing world as the inventor and developer of the Adams automatic bolt threading machines, by means of which any size threads are cut to a standard, thus making practical the interchangeability of bolts and nuts. When he favored us with a view of his single track, single column, perfectly safe single car railway, we felt inclined to doubt its practicability; and we looked around to see what stuff Mr. James W. Adams is made of himself; for antecedents often help to decide intellectual qualities. He is a native of Virginia, and not yet 35 years of age. From the Andreas *History of Chicago* we learn that he is the son of Hugh and Amanda (McCormick) Adams, the mother being a sister of the late Cyrus H. McCormick, the famous inventor. James W. came to Chicago with his parents, when only four years of age. He was sent to the scientific Phillips Academy, Andover, Mass., to complete his education; and therefrom he graduated as fourth in his class in 1871; after which he became engaged in the grain and elevator business. Subsequently he became inventive.

Mr. Adams' inventive talents are undoubtedly hereditary. Should the elevated railway system, to which he has devoted his mind for some time, turn out as he expects it will, the manner of operation, as well as the principle and manner of construction of elevated railways, in large cities, will certainly be revolutionized.

THE inventor is not alone in his good opinion of his rapid transit plan; but, as may be seen in another column, its practicability is certified by three of the most eminent engineers of the day. Mr. Artingstall is the city engineer of Chicago. Mr. Gottlieb is a leading authority on the mechanisms and qualities of bridges, roofs and iron buildings; while Mr. E. L. Gorthell is also an engineer of national reputation; and these three "have carefully considered the principles involved", and they deliberately and professionally declare that, "with some modification and further application of details, the system is both practicable, safe, economical and well adapted to the requirements of the traffic of large cities."



## Rules, Regulations, Uniforms, Etc.

By A. D. RODGERS, COLUMBUS, O.

(Read at the Sixth Annual Meeting of the O. S. T. A.)

A well organized working force, everybody will agree, is necessary to the successful operation of a street railroad. This may be said of all enterprises, of any magnitude, but not always, nor often, does it apply with equal force in other pursuits. The common carrier, in whatever line, accepts the risks incident to his business as an important factor in all his calculations. Especially grave is this responsibility in the case of street railroads, whose operations are carried on in thoroughfares thronged with people and vehicles, amidst the hurry of everyday traffic and the excitement, confusion and tumults of public occasions. Their patrons are numbered by the millions, and with each and every passenger, they accept the legal obligation to carry him or her safely; and to this end, are held to the exercise of the highest degree of care on the part of their agents. They do not always have the sympathy of the public; on the contrary, they are often unpopular, and this in most cases without reason. When we consider the vast number and variety of people with whom they have to deal—among them always a generous proportion of the fault-finding class and many others, who, if not strictly of this class, carry with them their business troubles and annoyances, and whose ruffled temper finds ready vent upon the occasion of the slightest irregularity—the frequent and often unreasonable demands of those who seek to use such organizations only to subserve their personal ends; and the fact too that their employees, whose patience is sorely tried by the people first referred to, often fail in both tact and temper, it is not strange that some prejudice does exist against such corporations.

Beset thus with dangers and difficulties, it is plainly of the highest importance that employees should be selected with care, and that over all there should be a just, but firm discipline. All should be men of good habits and of sufficient age, aptitude and scholarship to insure proper method and dispatch in the performance of their duties. They should be painstaking, good tempered, judicious, faithful men. There are some physical infirmities, such as defective eyesight or hearing, that disqualify for this work. It is quite certain that none of us in our experience always reach such a standard, but nevertheless it is simply prudent to make as near an approach as possible. Where many are employed, it must be done often in haste, and without full inquiry. It would require an exceedingly shrewd discernor of character, if mistakes are to be wholly avoided.

But it is not enough that good men should be chosen. Their duties should be clearly defined. They should be instructed. The rules should be plain and practicable. They should not be too numerous. Something must be left to the judgment of employees. The reason of a rule should be apparent. Sometimes it may be enforced in spirit if not to the letter. The thoughtful employee may often meet and provide for an emergency not anticipated.

I assume that every company belonging to this association has printed Rules and Regulations for the government of its employees. Aside from those having merely a local application, common experience has suggested their most important features and hence, probably, in their scope and intent they do not materially differ. For the most part, and enough for our present purposes at least, they may be grouped under the following heads:—

1. Those looking to the prevention of accidents to persons or property, and especially to the safety and comfort of our patrons, and to the convenience of the public generally; and in the same connection to the proper enquiry to be made when accidents do occur, into the cause and extent of the injury resulting, with the view to fixing the responsibility therefor.

2. Those providing for due care and humane treatment of horses; and, where motive power other than horses is used, for proper management of machinery, etc., peculiar thereto, and the care of the property.

3. Those relating to the collection and return of fares. It would be profitable no doubt to discuss many of these matters in detail, but that is not expected of me in this pa-

per. Nor will our time permit more than brief mention of a few things, and they nothing but an old story. Avoidance of accidents is of course the great desideratum. Our most important concern, and our greatest danger arises in receiving into and landing of passengers from our cars. But few accidents happen to people in our custody at other times. Lack of due care at such times often results in serious injury. The car is started before the passenger is safely on or off, and if harm results we are without excuse. Probably no one cause is more productive of accidents than this. Though these more frequently happen with fare box cars, yet it is not confined to them. The cars should be started only when the passenger is known to be safe, and should be started slowly. The printed Rules should say so in bold type. The front platform is a place of danger; when open, people will get on and off at this place, if allowed. When practicable our risk may be diminished by closing them in some way. Incidentally another benefit will result from this, in having fewer persons there to crowd the driver, and draw off his attention.

But the safety of passengers is not our whole concern. There is a constant liability to accident by collisions with our cars in the streets both to persons and vehicles. These are generally of the most serious character. They are to be avoided by the vigilance of the driver. But there should be also frequent and thorough inspection of the brakes by a person of competent skill. In crowded portions of the street the driver should always stand on his feet, his hand on the brake ready to exert all his strength in stopping his car at the first warning of danger.

Experience shows that notwithstanding all our safeguards, accidents do occur. The dockets of our courts too frequently bear evidence of this painful fact. We must be prepared to meet the charge of negligence in all cases. It is of the utmost importance that prompt action should be taken by our employees, at the very time and place, in gathering all the particulars in relation to an accident whether they appear to be serious or slight, whether involving persons or property. However trivial it may seem at the time, the nature of the injury, its extent so far as can be ascertained, the name and address of the person or the owner of the property injured, the names and addresses of all witnesses procurable, all these should be reported at the earliest opportunity to the proper office. A good case may be sacrificed by inattention to these precautions at the proper time. As we are in many cases saved from liability for injury, due partly to our own neglect, by the negligence of the party who suffers contributing thereto, it becomes necessary to be thoroughly informed as to the latter's participation in the accident. It may be safely assumed that the other side will not overlook our failures, and it is well that we should also know the weak points in our case, if any exist.

Before leaving this head I must allude to a question which, in caring for the comfort of our patrons, has no doubt confronted us all, I allude to the matter of smoking on the cars. Shall it be wholly prohibited? This question is a two-edged-sword, cleaving both ways. In most large cities, I am aware, it is forbidden, except on special cars. But differing conditions require different policies in dealing with this question in our several localities, and no such rule has been generally adopted, nor does it seem necessary. Manifestly, smoking should be restricted to the platforms of box cars, and the rear seats of summer cars; and even in these places it should be forbidden when it annoys any passengers. Our agents on the cars should be sufficiently alert to detect this, even without formal notice. The statutes of our state make it a penal offense for any person to persist in smoking after being requested by any of our employees to desist. \* \* \*

As to those rules coming under my second general head, I have little to offer. Others are much better qualified to make suggestions concerning Regulations for the proper care and treatment of horses; and as to those peculiar to other kinds of motive power, I am wholly without experience. When horses are used (and their entire discontinuance is not to be expected in the near future), rigid Regulations should be adopted and enforced to protect them

against neglect and cruel treatment. Much depends upon the driver. He should know something about a horse. He should be kindly disposed to the horse. There is one further suggestion I desire to make in this connection. A rule providing for stopping cars only at intersections of streets and alleys would save much time, and be a vast relief to our horses. There can hardly be any difference of opinion as to the desirability of such a rule for all concerned, if there could be secured a ready co-operation on the part of our patrons. Without such co-operation the rule fails in one of its important purposes, viz., the saving of time; but under all circumstances it would be of great advantage to our horses.

It remains only to submit a few general considerations in reference to the *collection and return of moneys due us for the service we render*. It is hardly necessary I should say that this is of *vital importance* to us, if not our first concern. This is a matter in which, at least *directly*, the public does not share our interest. There are, as you all know, many devices to secure honesty and fidelity in the discharge of these duties, and the Rules and Regulations vary with these. It may be safely said that no company nor individual can successfully operate a street railroad without some of these, and it is almost equally true, that the highest success will not be attained by depending entirely upon them. Eternal vigilance is the price of success in this, as it is in every other part of our work. These devices and regulations are not generally looked upon with favor, either by the public or our employees, and sometimes it is charged that they are an imputation upon the integrity of the latter. This is wholly unwarranted. In this, as in all other avocations, there are honest men and dishonest men. They are not intended for honest men. If by any means the dishonest are exposed and weeded out, should not all honest men thank us, and should not honest employees especially be grateful for relieving them of the association? As well claim that our public statutes are an impeachment of the integrity of all officials, because every man entering upon any important office or trust is required to give a bond, and also take an oath to honestly and faithfully discharge his duties. We seek only to accomplish the same end.

But neither is it enough that we should have good Rules and Regulations. These must be vigorously enforced. There must be a wholesome *discipline*. If good men are selected, and their duties are clearly defined, and they are well instructed, this task is an easy one. But unfortunately such experience is not common. As in the selection of our employees, so in their discharge, there should be the utmost freedom, and in both, the exercise of a high degree of care. In our vocabulary there should be no such word as "*Influence*." Dictation from any quarter, if allowed in the exercise of this important function, will destroy all discipline, and demoralize the service. Each employee should be made to feel that the tenure of his employment depends entirely upon his individual deserts. We should deal justly with them, as we expect them to deal justly with us. Their uniforms or badges (and I am clearly of the opinion that something should be worn to distinguish them), should entitle them to our respect, confidence and sympathy.

If I have had any special purpose in the preparation of these hasty and imperfect suggestions, it has been to magnify our work. Its importance, if measured merely by the responsibilities we assume, is great indeed to us. But it is important in a wider sense. In the communities where we operate, its influence is far reaching, and affects interests, moral as well as material, in a greater degree than is generally understood or appreciated. Nor must we belittle our obligations. There are Rules and Regulations to which we must all, whether superior in authority or subordinate, yield obedience. Some duties are not expressed in written terms, but none the less to be observed and enforced, because they rest solely upon and appeal only to our moral sense. Integrity, fidelity to obligation, fair dealing, these do not depend for their sanction upon any "formal expression," in rule or statute. Let us then, in our several places and relations, be faithful to all our obligations, and thus acting together in harmony for the common good, our work will be fitly done.

## Convention Papers Criticised.

Our last number, containing a full report of the proceedings of the American Street Railway Convention at Philadelphia, was issued as soon as possible after the convention was over, and has attracted much attention abroad as well as cis-Atlantic. It is interesting to read the views of our trans-Atlantic cousins on the papers read, and the discussions thereon, as reported in the *STREET RAILWAY GAZETTE*. Our British contemporary *Industries*, (published at London and Manchester, England,) has devoted its first two leader columns, Nov. 18th, to recapitulate, quote and criticise some of the statements that were made. It brings to the front Mr. D. Atwood's paper on motors other than cable or electric, "which is decidedly discouraging to the promoters of mechanical traction." And after summarizing the contents of that paper, and quoting the remarks on the Paris Tramway Co., *Industries* declares:

"It is hardly necessary to remind our readers that these expressions of individual opinion are not a perfectly correct statement of the facts. At the present moment there is a steam tramway in successful operation in London, and there are several in various provincial towns; and the number of steam tramway lines in and about Belgian, Dutch, French, and Italian towns, is very considerable. If steam tramways have not come into favor in America, the reasons are probably the bad condition of the roads and the desire to keep the weight of the locomotives down. In Mr. Atwood's opinion, the only system of mechanical traction which can at all compete against horses is that of the cable, and especially the new system now introduced in Chicago, under the name of the Rasmussen cable system, which Mr. Atwood, however, considers a misnomer, since all the details have been worked out by Mr. H. W. McNeill. Since this report was drawn up in compliance with an official invitation from the Council of the Association, we must consider it to be fairly representative of the opinion of American tramway engineers, and it would thus appear that no system of mechanical traction other than the cable is likely to succeed; but if we turn to some of the other papers read at the same convention, the case of mechanical against animal traction appears entirely different. There were, besides Mr. Atwood's, three other papers dealing with this question, all extolling the advantages of electric traction. One of these was by Mr. W. Wharton, of Philadelphia, another by Mr. Van Depoele, and the third by the Bentley-Knight Electric Railway company. The last named paper need not occupy our attention, as it was merely an eulogy of the particular system represented by that company, coupled with a fierce criticism of those companies who intend using, or are already using secondary batteries for street cars, but did not add anything to the scientific or practical information already in the possession of engineers. Mr. Van Depoele was one of the first in the United States to apply electricity to the propulsion of tram cars." Then follows a summary of the Van Depoele address. Afterwards Mr. Wharton's paper is recapitulated, ending with the statement that "the cells require 40 h. p. hours for each charge, and remain in use for four hours before being changed, thus representing an expenditure of about 70 h. p. per car. If we compare this figure with the result obtained on the North Metropolitan tramway in London, we find that Mr. Wharton has certainly not presented the matter in a too favorable light. His total rolling load is probably within seven tons, and to move this he considers the continued expenditure of 10 h. p. necessary; the total rolling load of one of the North Metropolitan company's cars and locomotives is 11½ tons, and only 8 h. p. is required to propel this load. Mr. Wharton assumes that three electric cars could do the work of four horse cars, and on this basis he estimates the annual working expenses, with coal at 12 s. per ton, and the keep of each horse at 2 s. per day, to bear the proportion of £2,600 to £3,360 for an equal traffic; thus leaving a margin of £760, or nearly 23 per cent. over the present cost, in favor of electric traction."

Now, mark this concluding paragraph of *Industries*:



"If we then sum up the lessons taught by the recent convention of the American Street Railway association, we find that whilst this body officially declare that steam, hot air, hot water, petroleum, and other purely mechanical engines have failed to compete successfully against horse traction, and that cable tramways can, only in exceptional cases so compete, yet they seem to endorse the private opinions expressed by the promoters of various systems of electrical traction; and the tacit acquiescence of so influential a body as this Association bodes well for a speedy development of electric power on tram lines in America. It will be well for our own electrical engineers to take note of the direction in which affairs are moving in America, so that they may not be left behind in the progress of this industry."

The moral of it all is this: The proceedings of the American Street Railway association carry great weight abroad as well as at home; and those who may hereafter prepare convention papers, should remember that carelessness or inaccuracies will tend to bring discredit upon the Association, while valuable information will have extended influence. Probably Mr. Atwood's paper would not have been worth criticising had it not been read before the Association; and although it was received without discussion by the members, their "tacit acquiescence" is naturally taken as an endorsement of the statements it contains, according to the rule that "silence gives consent."

DAYTON'S (Ohio) electric railway.—The White Star Street R. R. Co.'s—is checkmated (temporarily at all events): the citizens brought suit, November 3, to enjoin the company from constructing their road along North Main street, and a temporary restraining order was granted. The ground of the complaint is that "the citizens fear the building of the road will ruin the appearance of the street."

"ROBBED in a street car" is the caption of a special now going the rounds; it reads like a tale from some obscure out-of-the-way village; but it is dated "New York, Dec. 2," and says:—"Miss Bruce Torrens about 9:30 o'clock last night boarded one of the Twenty-third street bob-tail cars that run to the Thirty-fourth street ferry. Just after the car entered the cut that leads from First avenue to the ferry a man stepped quickly through the open door and made a grab at the purse which Miss Torrens was carrying in her hand. The only other occupants of the car were an old gentleman and a lady. Both seemed very much frightened, and did not move. Seeing no chance of assistance from them, Miss Torrens called for help. The driver apparently paid no attention. As the car neared the end of the cut the robber dragged the girl out of the car, threw her to the ground, took the purse from her, and ran away. She described her assailant, but no arrest for the outrage has yet been made."

### The Metallic Street Railway Supply Co.

Our friend "Mac" informs us that the reorganization of the Metallic Street Railway Supply Co. was perfected and transfers made, December 5th. President, Mr. A. N. Brady (president of the Municipal Gas Co.); Vice-President and Treasurer, Mr. R. L. Pruyn (president of the Commercial Bank of Albany, New York); Engineer, Thos. H. Gibbon (whose engagement with the Johnson Steel Street Rail Company expires on December 15th).

This has been accomplished after two years' close observation by these gentlemen and their associates, strengthened by the opinions of railway managers, who have watched with keen interest the tests going on with this system for the past two years. Its durability, above all other systems, is evidenced in the fact that nothing but iron and steel is used, and is constructed without the aid of spikes, bolts or fish plates. Railroad managers will readily see, and no doubt will avail themselves of these easements in railway building. We understand that large orders are now out for material. It is not definitely decided where they will erect their works.

The engineer (Mr. Gibbon) will devote his whole time and attention to the Metallic.

### Personals.

PRESIDENT CALVIN A. RICHARDS COMPLIMENTED.

It was early in 1875 that the fortunes of the Metropolitan Railroad, Boston, were at their lowest ebb. The stock was selling at 42, a decline of 50 per cent. from the highest figures of the preceding decade. It was thought advisable by stockholders and directors to make a radical change in the policy of management, and Mr. Calvin A. Richards was induced to relinquish many business cares and endeavor to ascertain if the old-time prestige of the valuable property could be recovered. The Highland Railroad had secured a franchise and was launched into immediate success, mainly because of the wide-spread antagonism against the unaccommodating spirit shown by its older rival. The energy at once displayed by Mr. Richards was felt in every department. The Directors have felt that confidence in the wisdom and far-sightedness of Mr. Richards' views that almost the entire guidance of the corporation has been left to him, and now that the West End purchases and amalgamations are to do away with the diversity of horse railroads, and join all under one banner, Mr. Richards' associates, on the Executive Board of the Metropolitan, thought fit to give him a banquet at the Algonquin club house, which was spread on the evening of Nov. 8th, before Messrs. William Hendry, Dexter N. Richards, William A. Rush, Stephen R. Niles, Thomas Dana, A. P. Martin, E. O. Shepard, Isaac Fenno, and their honored guest Calvin A. Richards.

Mr. Richards was presented, on this occasion, with a magnificent bronze "Hebe" upon a finely wrought pedestal.

MR. JOHN B. PARSONS, hitherto president of two street railway companies in Philadelphia, has been appointed General Manager of the West Chicago Street R. R. Co., and will "take charge" the 1st of January. The salary is \$10,000 a year, with a share in the company's earnings, we understand. It is more than that as some state. Our special correspondent, who writes our Philadelphia "pointers," says: "John B. Parsons, who resigns the presidency of the People's Passenger Railway Co., to accept the management of the Traction Syndicate in Chicago, is a practical railway man. Twelve thousand a year was a tempting offer. He will be succeeded by Thomas C. Barr, who holds the position of assistant to the President."

GEORGE CHASE, of London, England, John Wright, of Liverpool, and I. B. Bowan, of Liverpool, are making a tour of America and take special interest in our cable railways; they closely examined the cable lines of Kansas City, Mo., and also those of Chicago.

CAPTAIN JOE V. MEIGS and wife arrived at the Palmer House, Chicago, Nov. 30th, and the West Side Rapid Transit association, (which is as much inside the Chicago Rapid Transit company as Jonah was in the whale's belly,) are investigating the Meigs and other elevated railway systems.

LIEUT. J. J. GOSPER, a prominent street railway promoter at Los Angeles, Cal., was recently in Chicago, investigating the Van Depoele electric railway system, etc., and honored the STREET RAILWAY GAZETTE with a visit.

CAPT. ROBERT McCULLOCH, the president and superintendent of the Lindell Railway, St. Louis, has resigned that office and returned to the management of the Benton-Bellefontaine line.

MR. JOHN MAHONEY, formerly superintendent of the Northern Central, is superintendent of the new Citizens' Cable road, St. Louis, with Mr. John Burke as his assistant.

Mr. Thos. Bergin, late conductor, takes Mr. Mahoney's place on the Northern Central.

MR. GEORGE A. BAKER, superintendent of the Leavenworth, Kan., street railway, has also been elected president, in lieu of Mr. Thomas Stivers, who has resigned.

The Boston local Sunday papers of November 20th, spoke of the "clean sweep" of South Boston horse railroad

officials. The expression was too inclusive and the statement "too previous." Mr. Hersey, Mr. Coolidge and Mr. Cunningham are the only officers who have withdrawn. The offices of president, superintendent and treasurer have been abolished, but Mr. Cummings, late treasurer, and his assistants, Mr. Libby and Mr. Poole, are still in the employ of the new (consolidation) company and are still at the Broadway office, although they will soon be transferred. The receivers, Mr. Reed and Mr. Prouty, are at the offices of the company on Kilby street. Mr. Lovering remains at the Broadway office and receives the conductors' returns, who settle once a day, having until noon to turn over their receipts for the previous day's work.

MR. M. M. ALEXANDER, recently appointed Superintendent of The Citizen's Street railway of Wellington, Kansas, died Nov. 16 of Bright's disease. He was a son of Mr. D. P. Alexander, builder and principal owner of the Wellington street railway.

## POINTERS.

### ALABAMA.

"*Mobile.* The curve pertaining to the Belt line was furnished by the Mobile Street Railway Co., Nov. 12, at the corner of Charleston and Broad streets.

*Montgomery.* "Here, supposing you wish a street-car ride, you arrest the speed of no four-legged animal, but of a fleshless being, electricity," says Edmund Lille (in *Picayune*). The electric motor railway has been in constant use for the last year. The city is compactly built, and this street line, of which there are fifteen miles, connects the city at all points, and affords the transportation facilities needed."

### ARKANSAS.

*Helena.* President Greenfield Quarles, of the Citizens' Street Railway company of this city, has filed the bond required by the ordinance granting the right of way, which stipulates that the bond is to be forfeited unless a mile of railway is completed within one year, and a half-mile additional each six months thereafter until three miles are built.

### CALIFORNIA.

*Monterey.* Mr. Jonathan B. S. Maltby, of Troy, N. Y., has bought the Heintz building for a bank in this city. Mr. Maltby and others propose to obtain a franchise for a street car line connecting Pacific Grove, Monterey, Del Monte and the Houghton tract.

*Oakland.* A correspondent writes: "When Senator Blair built the San Pablo avenue and Broadway cable road, a year since, croakers said it would never pay. Instead of the six cars started with, ten are now used. Instead of an eight-minute service, five minutes is now the time between cars, and Secretary Neal is authority for the statement that the road pays \$25 per day, or \$750 per month, above all expenses.

*San Bernardino.* The Southern California Motor Road company has been incorporated. Capital stock, \$1,000,000. Samuel Merrill and others, incorporators.

*San Francisco.* The Powell Street Ry. Co. are pushing their cable system as rapidly as possible. It is expected to be in operation by January 1st. The engine house is built of brick, and has a frontage of 138 feet. It is three stories high; the first or ground floor is to be used as the engine and boiler rooms, and the machinery will also be placed here. The second story is fitted up with offices for the directors and officials, and the rest of the floor is to be used for storing the cars. Four engines are being erected of 550 horse power each. It is the directors' intention to run only two of these engines at a time, and have the other two reserved in case of accident. The fly-wheel weighs sixteen tons and is sixteen feet in diameter. The two main gears weigh eleven and a half tons each and are fourteen feet in diameter. Three cable ropes will be used, the first being 26,400 feet long, and is the longest on the Pacific coast. It is for the Washington and Jackson street line. The next rope is 18,000 feet long, and is for the Powell street line, and the next 22,000 feet long, for the line which will run to the ferry, making a total of 66,400 feet of cable. Thirteen cor-

ners are to be turned, and these all require more work than the main track.

The Sutter Street R. R. Co. are laying a cable line on Pacific street, which is to be finished by March 1st. This road will be a continuation of the Larkin street branch of the Sutter street road, and will be laid along Polk street, turn into Pacific and end at Buchanan street, and when this is completed, the company intend extending the road along Pacific street to First avenue.

The directors of the Powell street road have re-elected the old directors of the Park and Cliff House road.

*San Luis Obispo.* The street railway, to the length of two miles, through the principal streets of the city, is in operation, and the inhabitants are delighted therewith. Two handsome open cars are used, with two horses to each.

### ILLINOIS.

*Chicago.* The North Chicago St. R. R. Co. have paid \$1,592; the Chicago City Ry. Co. (South Side) \$3,508; and the Chicago West Division Ry. Co. \$3,202 to the city collector as license fees for the past quarter. The latter made 306,375 trips during the quarter. The Chicago Passenger Ry. Co. paid \$430.25 on account of 41,169 round trips during the quarter.

These quarterly dues are made in accordance with an ordinance passed July 30, 1883, each company stating by affidavit how many round trips have been made, and paying therefor \$12.50 per car, each quarter. "In computing the number of cars upon which such license charge may be imposed, thirteen round trips, when a car is used in the transportation of passengers, shall be taken as an equivalent to one day's use of one car. One-thirteenth of such round trips during each quarter shall be divided by the number of days in such quarter, such quotient shall be the number of cars subject to such license fee."

The Chicago & West Side R. R. Co. has been incorporated. The object is to build a railroad which is to commence at or near the western limits of the city of Chicago in Cook county, and terminate at or near the Desplaines river, in the town of Proviso, with a branch at some convenient point to Riverside. The capital stock is to be \$1,000,000, and the principal business office is to be in Chicago. The incorporators are Williston Fish, Frank G. Holton, John M. Brown, Dennis W. Sullivan, and Marshal Laham, all of Chicago.

"The transfer of the West Division Railway is an accomplished fact," said the Chicago *Herald*, Nov. 14. The C. W. D. Ry. Co. has leased its lines for a term of 999 years to the West Chicago Street R. R. Co., commonly called the Yerkes syndicate. The leasing company had a total of 12,500 shares, of \$100 par value, and the new company purchased 6,251 shares (a majority of two) paying therefor \$650 per share! And they have agreed to pay 35 per cent. per annum interest on the face value of the remaining 6,249 shares, which represent \$624,900, the same being treated as preferred stock.

The Chicago Rapid Transit Company, of Chicago, was incorporated, Nov. 4, somewhat hastily. The whys and wherefores are stated elsewhere in this number of the GAZETTE. Capital stock, \$1,500,000; incorporators, George C. Buell (30 Ashland Block), Jas. C. Beeks, and Edward S. Richards.

The Chicago Western Elevated Railway Company of Cook county was incorporated at the same time—about a neck ahead of the Rapid Transit people. Incorporators, James Felch (79 Dearborn street), Geo. S. Calkins, and Ezra L. Brainerd; capital stock, \$20,000,000. The declared object of these people is to construct and operate a trunk line of elevated railroad, commencing at a point on Michigan Ave., Chicago, between South Water and Monroe streets, and running west to the line of said county.

The Consolidated Rapid Transit and Elevated R. R. Co. have at last obtained a franchise to construct an "L" road in Hyde Park. The trustees passed the ordinance Nov. 18, a bond for \$100,000 to indemnify the "village" against any damage suits having been submitted and approved. This company has not yet succeeded to get right of way in Chicago. But the recent election decided in favor



of annexing the greater part of Hyde Park to the city, and the promoters of this elevated road hope to run into the heart of Chicago ultimately. Col. G. Howard-Ellers (4 Sherman street), is the general manager.

License of incorporation, and to open books for subscription to capital stock, was issued by the secretary of state Nov. 28 to The Southern Railway Construction and Improvement Company, at Chicago; capital stock, \$120,000; for the construction of street railroads and for other business in connection therewith; incorporators, W. R. Crumpton, H. C. Hartman, and W. R. Church.

The Union Passenger Ry. Co. are canvassing for consent of property-owners to build a horse railway along Third avenue from Jackson to Fourteenth streets and back along Fourth avenue. The officers of the company are: M. S. Forbus, president; L. H. Bisbee, secretary; and J. A. Edwards, treasurer. The office is at room 201, No. 205 La-Salle street.

*Decatur.* License of incorporation was issued Nov. 28 to the People's Street Railway company, at Decatur; capital stock, \$25,000; incorporators, John R. Miller, T. T. Roberts, and Jerome R. Gorin.

#### INDIANA.

*New Albany.* The New Albany street railway has been sold to Mr. W. H. Dillingham, and other citizens of New Albany; but we are informed that they only "figure" in the transaction, and that the real purchasers are the Kentucky & Indiana Bridge Co. Anyway, the new owners take possession of the property on December 10th, and will at once commence a thorough repair of its lines. Col. W. L. Timberlake, the old superintendent, has accepted the same position under the new management.

#### IOWA.

*Council Bluffs.* The City and Suburban Transit company has been incorporated by F. O. Gleason and others; capital stock, \$50,000.

#### KANSAS.

*Abilene.* President M. M. Shipe says he will continue the Grand avenue line of the Abilene street railway half a mile westwardly to the boulevard. The high ground in the western portion of Fairview will be lowered to the grade on Grand avenue, through which a four-foot cut will be made.

*Arkansas City.* The Arkansas City Street Railway Co. commenced running their cars Nov. 7, and the citizens, says our correspondent, "were given a free ride, to the delight of the small boy." We are further informed that there are not many cities in the great state of Kansas which can boast of as good a system of street railway as Arkansas City. Although all of the track is not yet laid, the patronage bestowed upon it has been sufficient to pay operating expenses. There are now two miles and a half of track down. This is all the franchise calls for from the company at present, but that enterprising body has determined to lay another mile of track, making a total of three miles and a half. On South Summit street an extension of the line will be made to the Missouri Pacific depot as soon as the material arrives. The extension will soon be completed to the Frisco depot. Five handsome cars are drawn over this perfect system of street railway, not by broken-down teams, but by the best pieces of horseflesh to be obtained in the western market. Arkansas City is to be congratulated on her street railway.

*Atchison.* It will cost the dummy line \$3,000 to cross the thirteen railroad tracks on Tenth street. Each road charges \$165 for right of way over every track.

*El Dorado.* A letter from the El D. Street Ry. Co. says the track is now being laid.

*Fort Scott.* The Bourbon County St. Ry. have pleased their patrons very much by placing "neat little heaters" in their cars.

A thriving business has been done here by a woman who bought tickets "by the quantity," thus costing  $2\frac{1}{2}$  cents each. She then gave her time to riding on the cars, and retailed tickets to the passengers at 5 cents each, and was doing a good business, until the superintendent forbade the sale of any more tickets to her.

*Garden City.* We are informed that the Garden City

Street Ry. Co. have ceased operations for want of patronage.

*Hutchison.* The Hutchison Street Ry. Co. has constructed its extension to Glendale Park in a satisfactory manner; and the rapidity with which the work has been accomplished caused no little surprise and admiration. They issued a time card, Nov. 26, giving the arrival and departure of trains from different points — "a boon highly appreciated."

*Kansas City.* The council of Kansas City, Kan., has granted a franchise to the Inter-State Rapid Transit Railway company for an extension of the road to Armourdale. The extension begins at Wabash avenue, Riverview, and follows a southern course to Shawnee avenue, Armourdale, thence west to Thirteenth street, thence south on Thirteenth street to Miami avenue, east on Miami avenue to Fourth street, north on Fourth street to Kansas avenue; also a branch from the junction of Thirteenth street and Miami avenue west on Miami avenue to the western limits of the town. A viaduct is provided for over the Union Pacific tracks at Armstrong, the cost of which will be divided as follows: Half by the "L." road, \$7,000 by the city, and the balance, probably \$3,000, by the Union Pacific Railway company.

Colonel D. M. Edgerton, president of the elevated road, has also made final arrangements with the owners of private property for a right of way over land which will enable that company to connect their Chelsea park line with the western extremity of the Riverview cable now in course of construction. When the proposed work is completed, a belt line will be formed which will encompass the northwestern portion of the consolidated city, commencing at the Riverview junction of the elevated road with the cable.

Street cars commenced running through from this city to Rosedale, Sunday, Nov. 6, and crowds of people went on every trip.

The Wyandotte Cable Line has also been opened, and celebrated, "in a casual way," by the emptying of several bottles of Mumm's extra dry. Much enthusiasm was created by the speeches that followed. The compliments to the Metropolitan Street Ry. Co. were responded to by W. B. Knight, chief engineer; E. J. Lawless, superintendent, and A. Rogers, division superintendent of the new branch line. Mr. J. C. Tarsney alluded to the fact that the business between the two Kansas Cities would soon require so many bridges over the Kaw that even a fish's life would not be a happy one. Ald. Joseph Pevy and others heartily endorsed the sentiments showing the unity of purpose and enterprise of the twin cities, and the reference to Kansas City, Mo., as the New York, and Kansas City, Kas., as the Brooklyn of the west.

*Kinsley.* Mr. S. B. Rickerson, president of the Kinsley Street railway company, visited Kansas City recently, and made partial arrangements for the purchase of three miles of track and four cars. It is the intention of the company to commence operations in a short time.

*Leavenworth.* The rapid transit line from Kansas City, Kans., to Leavenworth, was opened November 3d. The coaches — built by the Ohio Falls Car Co., at Jeffersonville, Ind. — are designed like the first coaches that were brought here by the "L." road, except that they are more elaborately furnished, and have fine upholstered cushions. The road "runs through the very garden of Kansas," and along its line is to be seen the finest scenery in the state. The people are delighted, many contemplating building elegant homes along the line, and all heartily wish great success to the Rapid Transit Suburban road.

An arrangement has been entered into between the Kansas City, Wyandotte & Northwestern railroad and the Interstate Rapid Transit company whereby the suburban trains of the former are to be transferred to the tracks of the latter and run over them into the very heart of Kansas City, Mo., as soon as the Bluff street tunnel extension of the "L." road is completed.

Further extensions are contemplated by the Leavenworth Street Ry. Co. They desire to make their system a belt line. Their new president (Mr. Geo. A. Baker) has had new tickets prepared, sold six for a quarter.

*McPherson.* The McPherson St. Ry. Co. has been re-organized. One-half of the capital stock has been transferred to Mr. Wm. West and wife. Mr. West is the president, A. L. Dodge secretary, and Oscar Seitz treasurer. Mr. A. A. Irvin is still connected with the company, and will attend to the general superintending. The track will be extended to the Kansas Pacific depot forthwith.

*Pratt.* The officers of the Pratt Street Railway Co. are, President, Geo. Kuhns, Pratt; Treasurer, Geo. S. Chase; Topeka; Secretary, E. M. Kuhns, Pratt. The company have let the contract for the erection of their stables, car house, and a residence for the superintendent of the road. These buildings will be erected on Walker addition, just north of the Rock Island depot. The iron and other material has all been purchased and ordered shipped. It is understood that the line will be completed and in operation before the beginning of December.

*Riverside.* Conflicting statements have come to hand respecting the electric railway across Riverside Park. One correspondent asserts repeatedly that it is a miserable failure, while others declare it a splendid success.

*Topeka.* The electric light tower, which was 150 feet high, fell down about 5 p. m., Oct. 24. It was erected five years ago, and was considered strong and firm enough to stand forever. It was "upset" by the breaking loose of a couple of street-car horses, which dashed up the adjoining avenue and leaped over the water tank on the north side of the tower, and then passed under the tower, one horse going on one side of the brace and the other horse on the other side, thereby wrenching the brace and shaking the tower, which stood on three heavy pipes. The tower fell, "and great was the fall thereof." Singularly enough, neither the horses nor anybody were hurt.

The Topeka Belt Ry. Co. was incorporated Nov. 11 by Chas. M. Clapp, Wm. S. Eaton, C. A. Browne, Henry C. Young, E. B. Abbott, A. E. Whitcomb, Albert G. Browne, F. R. Cordley, C. L. James, all of Boston; H. S. Burdett, Brookline, Mass.; Charles J. Gidden, Lowell, Mass.; J. H. Broadus, E. Wilder, George D. Hale, O. E. Walker and G. F. Parmelee, all of Topeka, all of the above named gentlemen being members of the Boston syndicate, which recently purchased 1,500 acres of valuable lands adjoining the city on the west. This company proposes to construct nine lines of railroad, which will reach a total length of fifty miles. The amount of the capital stock is \$1,000,000, and the directors for the first year are F. R. Cordley and C. L. James, of Boston; E. Wilder, George D. Hale, O. E. Walker, J. H. Broadus and G. F. Parmelee, of Topeka.

The contract for the grading and bridging of the line to Martin's hill has been let to Messrs. Price and Gavock. It is expected that the line will be completed and in operation by May 1, 1888. Mr. Price is a resident of this city, and his firm is one of the largest contracting firms in the west.

The grading of the Highland Park line is in progress, and will be finished before the 1st of January.

The North Topeka, Silver Lake and Rossville Rapid Transit company has been incorporated, with a capital stock of \$250,000, divided into 2,500 shares of \$100 each. The charter was issued for ninety-nine years. The purpose of the company is to construct, maintain and operate a railway, telephone and telegraph line from North Topeka to Rossville, in Shawnee county, and in the operation of said railway, said corporation may use and employ cables, steam motors, electricity, or such other motive power as the corporation may deem best. The length of said road is estimated at thirty miles. The nine directors appointed for the first year are: J. C. Watt, president; A. J. Arnold, secretary; S. N. Bergen, A. W. Pliny, J. Q. A. Peyton, treasurer; John M. Bryan, M. F. Campbell, Ed. Buechner and Geo. Stoker.

At a meeting of the Shawnee county board, Nov. 19, it was resolved to call a special election in Silver Lake township Dec. 30, to vote on a proposition for the township to subscribe for stock to the amount of \$15,000 in the North Topeka, Silver Lake & Rossville Rapid Transit Railway company. It is understood that Rossville will be asked to vote on a like proposition for \$10,000; Menoken, \$8,000, and Soldier, \$8,000.

The car-drivers of the Topeka city railway were recently told they should have to stick to their posts without stools. Naturally there was great dissatisfaction, and the following has been sent us as a specimen of the drivers' grumble: "That great big overgrown baby from Boston says we are not to have our stools any more. Some, in fact, all of us, are in for a general strike, and if we can get all the boys together in the morning we will go on a general strike. But unless we can all quit at once, we will not undertake it. We mean business, and are not going to submit to this Boston idea nonsense." Public opinion took the same side, and the "idea" had to be abandoned. Twenty-five new seats have since been fixed.

A new street railway ordinance was signed by Mayor Metsker, Nov. 18, which provides that no one constructing or operating any street railway in the city shall disturb the surface of any street any distance to exceed the length of three blocks, at any one time, and immediately on the completion of railway over or along any one of the three blocks the company shall within the time specified in their special permit, cause said street along said railway to be put in proper, safe and convenient condition for public travel.

The ordinance provides the following rules for the operation of street railroads: No cars when not in actual use for passenger travel, shall be kept standing in any street or other thoroughfare. No street railway car shall be drawn or propelled at a greater rate of speed than eight miles an hour. No car shall be drawn or propelled at a greater rate of speed, faster than a walk, while turning the corners from one street to another. No cars driven or propelled in the same direction, shall approach each other nearer than the distance of three hundred feet, except in case of accidents, unless said cars are coupled together as a train; no car shall be allowed to stop on the cross-walk except to avoid collision or to prevent danger to persons in the street; when any car shall be required to stop at any cross-walk to receive or leave passengers, it shall be stopped so as to leave the rear platform partly over the cross-walk, the conductor or driver of any car, and the person operating the motor of any car or train of cars, shall keep a vigilant watch for all vehicles and persons on foot, especially children, either on the track or moving towards it, and on the first appearance of danger to such persons or vehicles, the car or motor shall be stopped in the shortest space possible; conductors or drivers shall not allow ladies and children to leave or enter the car while the same is in motion. Conductors or drivers shall announce to passengers the names of the streets or the place where the cars connect with or intersect any other street railway line, and shall announce the name of each street crossing, at least fifty feet before the car reaches said street crossing. The driver or conductor of any street railway car shall stop the same immediately on being called to or hailed by motion or otherwise by any person for that purpose. All cars after sunset shall be provided with suitable colored lights. All street railway cars shall be brought to a full stop before crossing any other street railway track.

"The Street Railway War" has terminated, to the advantage of the Rapid Transit company. The application of the Topeka City Ry. for an injunction restraining the Topeka Rapid Transit Street Ry. Co. from interfering with certain tracks, together with the similar application by the latter company against the other, have been disposed of by Judge Guthrie, and resulted in a "double perpetual injunction"—the tracks of the city railway were ordered to be replaced in proper alignment, and the Rapid Transit Co. permitted to lay their tracks at the disputed point. Each party had to pay their own costs.

*Ulysses* has a street railroad company with a capital stock of \$100,000.

*Wichita.* The new extension on the west side is to be completed by January 1st.

The Daft system is to be used on the Central Avenue motor line. The poles for the wire will be 30 feet long. Mr. W. D. Davis assures us that this new railway will be first-class.

The Fairmount motor line is now in operation. It runs



as far south and west as the intersection of Thirteenth and Emporia avenue, where it makes connection for the present with the city railway company's lines.

Mr. J. O. Davidson, who built the present "electric" road, says arrangements have been completed for putting in a cable line, and that while he thinks it would prove more profitable in the hands of the present street railway company, he will be compelled to build it if they won't, so it will have to go in.

#### LOUISIANA.

*New Orleans.* The expired franchise of Canal and Claiborne Streets R. R. Co., is still "a dead letter." The city council discussed it for four hours Nov. 22, and left it where it was after all. Chas. S. Rice & Co., offers \$65,000 for the rights of the streets but decline to undertake liabilities of a suit by those who hold the "expired franchise;" and the Council refuses the present company's offer of \$55,000.

The following communication was read, Nov. 29:

"NEW ORLEANS, Nov. 29, 1887.

"To the Honorable the Mayor and Council of the City of New Orleans: Gentlemen—The Canal and Claiborne Street Railroad Company hereby renews its bid of \$55,000 cash for a renewal of the franchise which expired in May last on the specifications last advertised and now on file. As an earnest of its offer the company herein transmits its certified check for the amount of the bid, payable as soon as the contract between the city and the company is signed by the mayor.

"In addition to the offer already made, which is the best that the company, under any and all circumstances, could afford, the company suggests that the acceptance of its offer will at the same time discontinue all pending litigation and disembarass the council in every way. Trusting that the offer will be acceptable to the city, in the name of the company I have the honor to remain,

"Very respectfully, your obedient servant,  
"CHAS. K. HALL, President, etc."

Dr. Devron said he thought the bid the most advantageous the city could get, and were it possible he would move the acceptance immediately. As it was he would introduce an ordinance later accepting the bid. Mr. Lord saw no necessity for haste, and thought the bid premature. It was only a week since all bids had been rejected and the city attorney ordered to ascertain the city's legal rights in the matter. He thought the matter of bids could be held in abeyance until the courts determined the city's rights. Mr. Moon held that it was important to accept the bid. The city owed about \$26,000 for 1886, and the acceptance of the money would pay off the city's obligations for that year, which would be of more benefit than any small increase on the bid which might be received at the end of long litigation. He thought, as it was only a renewal of the franchise, the bill could be accepted on a single motion by a majority vote of the council.

The chair referred the letter to the committee on streets and landings.

#### MASSACHUSETTS.

*Boston.* The anxiously-looked for transfer has been made to the West End Street Railway company of all the rights and franchises of the Metropolitan Horse Railroad company, of the Consolidated Street Railroad (comprising the roads formerly known as the Highland Street Railway and the Middlesex Horse Railroad) and of the South Boston Horse Railroad company. Receipts and vouchers have been exchanged, and the West End has come into full and complete possession.

The pay of the South Boston car starters has been reduced to correspond with that of the conductors and drivers.

The new cars that have been running from South Boston to the Mechanical Exhibition will soon be put upon the route across Broadway Bridge to Washington street.

A correspondent writes the *Boston Herald* about Richmond, Va., its people, its industries and its dust. Referring to the "electric tramway" in that city, he says: "Some few of the thoroughfares in the residence quarters are excellent. Franklin street, well shaded, and bordered with delightful

mansions, is one of these, but the beauty of Franklin street only serves to emphasize the abounding plainness of the other thoroughfares. Some of Richmond's streets are being made even more ungloriously still by the construction of an electric tramway which necessitates a row of ugly poles along each curb, with wires crossing from side to side and supporting another wire which follows the track at a distance of 20 or 25 feet above the pavement. Nothing uglier could be devised. If this is the sort of thing that accompanies the introduction of electrically propelled street cars, may a gracious Providence keep electric cars out of Boston! Perhaps Mr. Richards' plan is less primitive, however."

*Brockton.* A public hearing was held at Brockton, Nov. 7th, before the board of aldermen on the petition of the directors of the East Side railway for a location, and to hear all remonstrants as to why the petition should not be granted. The route proposed was from the corner of Main and Crescent streets. Judge C. W. Sumner, on behalf of the Old Colony Railroad corporation was the first remonstrant against the manner, number of times and places which the proposed street railway would have to cross the Old Colony's tracks. The counsel then objected to the using of the Brockton street railway rails on Main street by the new company.

*Haverhill.* The new president of the Haverhill and Groveland Street Railway company is Hon. Levi Taylor; secretary and treasurer, John A. Colby; directors, Levi Taylor, Ira O. Sawyers, Ira A. Abbott, John A. Gale, William H. Smiley, John A. Colby, Philip C. Swett.

*Plainville.* A petition for the street railway to Attleboro received a long list of names in this village on November 19th.

#### MICHIGAN.

*Grand Rapids.* The new cable cars here will be propelled by a cable 1,200 feet long, which weighs ten tons.

#### MISSOURI.

*Independence.* The Jackson County Court has granted a cable railway franchise to the Centropolis Valley Railway Co., from the terminus of the Grand Avenue cable to Independence. The granting order provides that a certain part of the construction shall commence by May 1st, 1888; a certain part to be finished within two years from date of order, and the rest within four years.

*Kansas City.* The Wyandotte extension of the Fifth st. cable line of the Metropolitan St. Ry. Co., has been in operation a month. Chief Engineer Knight sent out a train at the first starting of the cable. It was not considered necessary to twirl the rope through the tube before applying the grip. It is four miles long. General Superintendent Lawless was on the train, and District Supt. Rogers was at the grip the first trip. The first train ran as smoothly as if it had been in practice a month. The "celebration" of the opening, held subsequently, is reported under Kansas. The exact length of the cable is 23,500 feet. The line turns four corners and crosses four steam railroad tracks. The corners are turned with parabolic curves which makes the turn shorter than with the perfect curve, but the cars move around them with perfect ease.

Additional cars have been placed on the Grand Avenue cable line, and the South Grand Avenue line has just been opened.

Work has begun on the Prospect avenue horse car line and a force will be kept at work until two blocks are laid and there the work will probably stop for a time until the avenue is graded. As soon as this is done the line will be pushed forward to completion.

The Kansas City Cable Ry. Co.'s new plant has cost \$150,000, and it is the largest and most extensive in the country, it is said, "the Chicago plant ranking second." There are two Wright engines, with a capacity of 400 horse power each, and ponderous drive wheels for three separate cables, as Engineer Wise informs us. The boiler room is an immense institution of itself. The smoke stack is 170 feet high, and is the largest in the city. The top of the stack is the highest point in Jackson county. The car room of the new house contains two tracks, and only fourteen cars will be accommodated; the balance will be kept at the Ninth street house.

Fourteen new grip cars and fourteen new coaches for the Troost avenue line are stored at the company's headquarters on Ninth street. The grips came from the LaCledé works, St. Louis, and the coaches from the works of the John Stephenson Co., New York. They are painted a pale yellow, striped with carmine. The front and rear ends bear the words "Troost Avenue and Union Depot." Upon the sides are merely the words, "Troost Avenue."

The Prospect Park Rapid Transit company, of Kansas City, was incorporated Nov. 21st; capital \$50,000, all paid up. The object of the organization is to construct, maintain and operate a motor railway from Troost avenue to a point on Thirty-third street near Brush creek, a distance of about five miles.

The Kansas City Electric railway is much admired. Extensions are contemplated; and other lines are likely to be converted to electricity.

The aggregate length of cable lines in operation in Kansas City, at the present time, is 17.4 miles, while 13.4 miles more are under construction, and franchises have been granted for a further length of 6.8 miles. Then 20.5 miles are projected, but for which franchises have not yet been obtained.

*St. Joseph.* At a meeting of the directors of the Wyatt Park cable line, Nov. 3, the capital stock was increased from \$200,000 to \$500,000. The contractor, Mr. Lerner, will remain in St. Joseph until the road is completed, and according to contract it is to be finished by March 1.

The Frederick Avenue street railway has brought suit against the Union Street railway for \$100,000 damages on the ground that it owns and has the exclusive right to use the land on Frederick Avenue, now occupied by the Union company. The Frederick Avenue company also demands a monthly rental of \$500 from August 24, 1886.

Sprague motors are most highly appreciated in St. Joseph. A correspondent says: "The round trip from the street car barn to New Uln Park was made in eight minutes, a speed of about ten miles an hour. There now appears to be no doubt of the success of the Sprague system. There is scarcely any noise attached to the running of the cars, and the cars glide along more smoothly than either cable or horse cars and resemble the running of cars over an elevated road. It will be a big thing for St. Joseph and the Union Street car line when the entire road is operated by electricity."

*St. Louis.* Mr. Chas. Green, President of the People's Ry. Co., was "converted" to electricity, while at the Philadelphia Street Railway Convention. Mr. Christian Peper, the Broadway street manager (St. Louis R. R. Co.), is apparently another convert to electricity. He thinks there is no question of the success of the operation by conduit or overhead wire; "and the only question as regards the storage battery is one of durability and expense."

#### PRESIDENT JULIUS S. WALSH COMPLIMENTED.

The Franklin Avenue cable railway branch of the Citizens' Ry. Co., of St. Louis, was formally opened Nov. 23, when about 200 leading citizens attended. Two magnificent Corliss engines drive the cable. One of these is named the "Isabel" and the other the "Josephine," after President Walsh's two daughters. The main fly wheel weighs 83,000 lbs. Mr. Augustine W. Wright, the chief engineer, and formerly of The Wright-Monroe company, states that this down-town cable is 30,500 feet long, and will contract and expand or stretch up to a length of about 1 per cent. of the whole rope without breaking. The Grand Avenue cable will be 16,500 feet long; and the Western extension, 22,000 feet long. "In all, there will be nearly 70,000 feet of cable worked by these machines." The opening ceremony comprised enough of cold partridge for everybody to have enough and to spare. And after the uncorking of bottles and clinking of glasses had subsided, numerous speeches were made. "The gist of all the addresses was alike laudatory of the enterprise and its president. It was stated that the cable would add millions of value to Northwestward St. Louis." Congratulations were received from Mr. C. B. Holmes, the president of the Chicago City Cable Railway, and from many

foreign street railroad men, and the gathering was a most pleasant one.

The Jefferson Avenue Railroad company reports 34,110 trips, and 436,630 passengers carried the last quarter; the Mound City, 44,834 trips and 553,394 passengers; the Union Depot, 102,230 trips and 1,312,729 passengers; the Bellefontaine, 53,694 trips and 573,634 passengers.

#### NEW JERSEY.

*Elizabeth.* The formal opening of the through route between Elizabeth and Newark, over the Elizabeth and Newark Horse railroad, which has just completed its line, took place Nov. 24. Two special cars left Elizabethport at half-past one o'clock, and ran through to the Paterson depot, Newark, and back, a distance of nearly thirty miles. The fare for the round trip is twenty cents.

#### NEW YORK.

*Brooklyn.* At a recent meeting of the trustees of the Brooklyn Bridge it was voted to purchase a part of the property at No. 278 Front street, in order to save the bridge from damage by fire. The contract for the extension of the bridge structure in Brooklyn to Nassau street, was awarded to the New Jersey Steel and Iron company. The ordinances authorized by the last Legislature were adopted, forbidding the following misdemeanors, punishable by fine or imprisonment: "Interference with the electric lights, placing any advertisement on the bridge, driving faster than five miles an hour, any obstruction of the cars or carriage ways, opening the platform gates after they are closed by the train hands or police, standing on the platforms of cars, jumping or dropping from the bridge, or going on the bridge for that purpose or to assist any one else in so doing; any disorderly conduct, any interference with passengers or hindering their going in the cars, and endangering life and limb by creating a panic or in any other way."

Henry W. Sage & Co. have begun proceedings against the Kings County Elevated Ry. company. The firm claims to have owned 800 shares of the original stock since 1883. It is alleged that the directors have entered into a conspiracy with Henry Bradlee, a contractor, to build the road as a syndicate and receive all the bonds and stock. They are thus to receive a large amount of the stock, securities, profits and issues of the company belonging in right to the stockholders. The court has granted an ex-parte order in the case to examine Edward A. Abbott and Harvey Farrington, directors, Henry J. Robinson, secretary of the company, and Bradlee, the contractor, in order that a complaint against the company may be framed.

There was a tremendous crash Nov. 16, in Flatbush avenue, near Third avenue, Brooklyn, and the work of constructing the Flatbush avenue branch of the Union Elevated railroad, which had reached that point, was brought to a sudden stop. The massive iron girders, comprising the last span of the structure and the greater part of the mammoth traveling derrick, gave way, and tons of wreckage struck the ground with such force as to shake the adjoining buildings. None of the workmen were injured except Edward Shier, who jumped from the structure, twenty feet, to the street, and broke his ankle.

The station of the Prospect Park & Coney Island Railroad, and the stables of the Vanderbilt Avenue Horse Car Line, with a large quantity of feed and ling stock and 157 horses, together with some dwelling houses adjoining, were burned on the night of Nov. 14., causing losses, estimated as follows: Building, \$22,000; cars, \$17,000; horses, \$22,000; and feed, \$4,000. The horses and property are insured for \$67,000. The P. P. & C. I. R. Co. estimates its loss at \$15,000, and the dwelling houses were worth about \$30,000.

*Buffalo.* The Citizens' Ry. Co. has been incorporated, by A. P. Wright and others, with a capital of \$150,000.

*New York.* The three weeks' trial of the Field electric motor on the Thirty-fourth street branch of the Third avenue elevated railway in New York City, ended October 8, and proved a grand success, we are informed.

The elevators running to the elevated railway station at Eighth avenue and One Hundred and Sixteenth street are now in operation. The brick elevator building is 26x18



feet on the ground and five stories high. It contains four elevators, with a capacity of about 100 persons a minute. These are running free night and day, and no one needs to climb the dizzy stairs, which are anything but golden. The improvement cost \$50,000, and was paid for by property-holders in the vicinity, the value of whose land has already nearly doubled, it is claimed. The Manhattan Railroad company has a fifty years' lease at a nominal rental of \$1 a year.

There is a fresh storm brewing in the ranks of the Knights of Labor. The Powderly faction think a vigorously conducted strike would strengthen their ranks; and they contemplate beginning operations by making demands that would never be conceded against the Third Avenue surface road. But Master Workman Powderly prays for deliverance from his "friends" and it is certain that he will not uphold "useless and senseless strikes."

A tunnel under the East river is planned from Long Island city to Ninth avenue and Thirteenth street, in New York city, and canvassing has begun for the consent of property-owners to tunnel under them. The width of the tunnel is to be 27 feet, and the height 21 feet. It will have a double track, and electric motors will be employed. The fare is to be five cents.

A boiler of one of the engines of the 3d avenue elevated railroad burst on the track at the corner of Grand street and the Bowery Nov. 3. The explosion shattered glass in the windows of neighboring houses for the distance of a block, and panic reigned in the streets as well as on the cars attached to the engine. The engineer was badly injured, and a man on the street was struck by a flying missile.

As we go to press a letter comes from New York saying that a cable railway company has been formed with a capital of \$10,000,000 to build a surface cable railroad from the battery to Fort George, near King's bridge, through West street, Broadway, and One Hundred and Fifty-fifth street. Among the incorporators are James J. Coogan, Isaac L. Peet, and the famous Lawson N. Fuller.

It was officially announced, Nov. 13, that the Third Avenue surface road, of New York, has decided to change from horse to cable traction, as stated in previous issues of the GAZETTE. Three-fourths of the stock was represented at the stockholders' meeting at which the change was decided upon. The estimated cost of the change, including rolling-stock, is \$1,500,000. The company will issue \$5,000,000 first mortgage five per cent. bonds for this work, and for refunding the present debt of \$3,500,000.

The Street Railway Construction Co. has been incorporated by Cornelius V. Sidell and others, with a capital stock of \$600,000.

The Field electric motor has been running every day from 10 a. m. to 12 m. for some weeks over the Thirty-fourth street branch of the Third Avenue Elevated railroad. When originally built, it was intended to be placed under ordinary passenger cars, but Col. F. K. Hain, of the elevated road, preferred to see it work as a separate machine, and it was built so. The trial machine weighs nine tons, and runs with a power of fifteen miles an hour. In actual service there will be two nine-ton motors on each train. Mr. Field has been greatly simplifying the machinery. The jerky movements of steam motors in starting, caused by the pressure first on the cylinder of one side and then on that of the other, is done away with in the electric motor. The power comes direct from the center, as the wheels couple immediately on the armature.

The fare-registers in use on the street railways to insure the honesty of conductors in collecting fares have been the subjects of long litigation. A suit was begun against the Third Avenue Railroad company for an alleged infringement of patent in the registers which have been placed in the cars of that road. Judge Wallace, of the United States circuit court, has filed an opinion dismissing the complainant's bill on the ground that there was no infringement of his patent. A large amount of money was involved in the controversy.

The following officers of the New York Cable Ry. Co. have been elected: President, Wm. S. Williams; vice presi-

dent, Joshua B. Shaw; treasurer, Thomas W. Evans; secretary, Abraham L. Earle.

Superintendent Richardson, of the Bureau of Obstructions, has reported to Gen. Newton, commissioner of public works, the result of his examination of the structures built by the elevated railway above the tracks from One hundred and fifty-fifth to One hundred and fifty-ninth streets on Eighth avenue. These structures are two and three stories in height, and extend over the sidewalk ten feet and seven inches on the east side, and three feet and two inches on the west side. They completely cover the roadway and are obstructions, although used for the business of the road at its terminus. The report has been referred by General Newton to Corporation Counsel O'Brien with the request that he state what authority General Newton has in the case.

Property owners on both the east and west sides of Central Park are requesting the Park Department to permit tracks to be laid through the transverse or sunken road at Eighty-fifth street, for street cars. There are now no means of reaching cars except from Fifty-ninth street, to cross the city near Central Park, and persons living above Eightieth street are obliged to go more than a mile to reach those cars. The Park Commissioners say that they are willing that the sunken roads should be used by street cars, but the opinion of the Corporation Counsel is positive that the law will not admit of this. It reads that no railroads shall go through Central Park "except by tunnel"; if to this be added "or by transverse road" the desired result may be reached. The Fourth Avenue line has tracks laid to the entrance of the Eighty-fifth street transverse road. The change, it is expected, will be secured from the next Legislature.

*Rochester.* Justice Dwight, who recently denied the motion to dissolve the injunction restraining the sale of the Plymouth avenue street car franchise, has written an opinion in which he states that it is claimed that the conditions of the sale imposed by the common council are illegal, unfair and unreasonable, and that in order to get at the truth of the matter it will be necessary to try the various issues in court. He is therefore of the opinion that the sale should be postponed until after such trial has been had. As a result of this decision, and acting upon the advice of counsel, City Treasurer Davis has declared the sale indefinitely postponed. This disposes of the project for the present, and the people of south Rochester have as little prospect as ever of gaining street railroad connection with the center of the city.

"And Still They Come" is the heading of a list of old complaints—very old ones—published by the Rochester *Herald* against cable railways. A couple of affidavits are inserted "testifying to injuries and wreckages caused to horses and vehicles by cable cars in Chicago." The object is to discourage the introduction of cable railways into Rochester, which is not improper to do; but it is hardly as proper to withhold the dates of the far-fetched affidavits. The natural inference drawn by the uninformed is that these complaints have but recently been made, whereas they were concocted years ago, when the Chicago cable railway system was in its infancy; and no one would now think of wasting time to put them together. Arguments must be very scarce when such a dodge as this has to be resorted to.

#### OHIO.

*Cincinnati.* An ordinance has been passed to restrict the beating of gong bells on the street, by cable cars and by the fire and police patrol departments. It is a shot, we are informed, at street advertising wagons. The old three-minute street car ordinance has gone from the Councilmen to the Board of Aldermen.

All night cars have been running on the Vine street line, between Mohawk Bridge and Fountain Square, since November 19th.

The residents of Ohio avenue have filed complaint with the Board of Public Affairs that the commutation tickets issued for rides between Clifton Plane and Fountain Square, via the Vine street or Elm street lines, have been refused by the conductors of the Vine street line, in violation of the agreement had between the property owners

and the Consolidation Street Railway company on June 17, 1882. The complaint has been referred to Mr. Jacob as a special committee of one to confer with the solicitor.

At about six o'clock, Nov. 28th, the upper section of the Walnut Hills cable parted, but happily broke right in the engine-house, where splicing was comparatively easy. The splice was made and the whole system running again before eleven o'clock. The accident happened when the up-hill traffic was the heaviest. Cars containing perhaps 1,500 passengers were left standing on the track in the midst of weather uncomfortably cold. Meanwhile the Eden Park cars were running and loaded to the guards, and the corners of the streets marking its course downtown were literally thronged with people waiting an opportunity to get home.

The festivities which were contemplated to celebrate the opening of the North Cincinnati Cable road were abandoned after the Committee of Arrangements fully considered the matter, and it was thereupon resolved to have no banquet.

The Sycamore Cable road is completed. The cable of this road crosses that of the Walnut Hills road in two places, and the grips of one cable are raised from 6 to 8 inches to pass the other cable.

A resolution has been passed to compel the Consolidated company to take up their track on the west side of State avenue, from Liberty to Eighth; also to remove their turntable at the corner of State avenue and Liberty street, it not having been in use for more than one year.

The street railway company has been ordered to repair sidewalks and construct temporary crossings on Jefferson street.

**Cleveland.** The ordinance giving the Woodland Avenue & West Side Street Railroad company the right to lay tracks on both branches of the Central viaduct, when it is completed, and out Scranton avenue to the city limits, by way of Jennings avenue and Willey street, was considered by the Board of Improvements October 10. Amendments were proposed reserving the right to the South Side Street Railway to use the bridge, and stipulating the amount of paving to be done by the company on Scranton avenue, and the entire matter was referred to the mayor, the solicitor, and the engineer. The clerk of the board was requested to write to Chicago for information concerning the handling of the bridges and the government of the bridge tenders in that city.

The board decided to report adversely upon the resolution of Councilman Missar, reducing the hours of labor upon the city swing bridges.

The East Cleveland Railroad company can only build one new car a fortnight, which is inadequate to the demand. They have, therefore, ordered "six palace street cars from a prominent Eastern manufacturer, to be delivered before Christmas, which are promised to be the finest cars ever operated in Cleveland."

The dispute between the Garden Street Ry. Co., and the East Cleveland R.R. Co., was referred to City Solicitor Brinsmade. After due investigations, at some of which lively altercations broke forth between the contending parties, the solicitor's opinion was delivered Nov. 14th. The new company claimed that the right of the East Cleveland R.R. Co. to operate its Garden street branch, expires the 14th of January next—the franchise having been granted Jan. 14, 1868, for 20 years: but the Council subsequently extended the time to March 22, 1905, and "there's an end on't."

#### PENNSYLVANIA.

**Oakland. (Allegheny Co.)** The Squirrel Hill Railway Co. has been incorporated. We are not informed as to the amount of capital. The new Squirrel Hill railway, says our Pittsburgh correspondent, will reach town from Oakland over the line of the Traction company. The Traction's cars will take the Squirrel Hill vehicles in tow and draw them into the city. The Squirrel Hill line will pass through that portion of the city which Chris. Magee was alleged to have contemplated for a large city park. That is to say, it will open it up thoroughly and exploit it to speculators in land, *et hoc genus omne*. The land in question is all that lying between Squirrel Hill and the Monongahela river, and extending

from oakland out toward the bluffs overlooking the river. The new line will pass over the well known highest point on Squirrel Hill, from which the top of the Blue Ridge, 30 or 40 miles distant, can be seen on a clear day. Indeed the various bits of scenery along the line will be highly picturesque. A new York gentleman, passing over the route of the new railway the other day, gave it as his opinion that the view along the bluffs was a perfect reproduction, in miniature, of that of the Hudson river just before reaching the famous Hotel Kaaterskill.

The exact route of the new road will be from Oakland, by way of Homewood and the German cemeteries, to the Colfax school house. A competent railway corps are now hard at work on the road. The officers of the company are George W. Morris, president; Alex. Murdock, vice-president; Robert Q. Whitten, secretary, and J. M. Hoch, treasurer. The road is between three and four miles long. It has been erroneously published that the road was to be elevated. This will only be the case over natural obstructions.

**Philadelphia.** The lease of the Lombard and South Street line to the People's has been declared "off." It had to be, as it was enjoined by the Common Pleas Court. At a recent meeting of the People's company resolutions were adopted withdrawing the endorsement of the lease. Transfers of passengers will be made as usual.

"Passengers must not stand on the rear platform" is the latest order of the Traction company.

What next! It is now charged that the Cable cars are responsible for the defective eyesight of some of its patrons; that the reading of newspapers and books, owing to the motion of the cars, is injurious to the nerves of vision. Why pick out the Cable? But in Philadelphia everything is charged to Traction. How unjust!

Wm. Wharton, Jr. is convinced that electricity is the coming motor power for passenger railways.

The Swem automatic switch is being taken hold of by the 2d and 3d, 4th and 8th and 13th and 15th st. lines.

The 13th and 15th street line has built an ambulance of its own. Supt. Cooper is credited with added improvements, which make it far superior to other vehicles of the kind. For the removal of a sick or dead horse, it could be called into requisition at once.

Wm. R. Warner, the well known wholesale druggist, has presented his friend Pres. Ackley of the 13th and 15th, with an "apothecary shop" for use in the stables of the road. It is complete in every detail.

The Traction company will commence in a few days to run the lower end of the Seventh and Ninth streets branch. The iron cord was dragged around on Sunday morning by a number of horses, and when the entire length had been laid on Sanson, Seventh and Ninth streets it was found to be just 21,500 feet long.

**Pittsburgh.** The Pittsburgh and Allegheny Traction company, capital \$1,000,000, has been chartered. J. R. McCreery, John B. Jackson, D. E. Henry, R. H. King and Wm. Roseberg are the shareholders. The company will construct a cable road from Pittsburgh to Allegheny, but will not begin operations at once.

An engine attached to a freight train on the Fort Wayne railroad struck a street car at the Federal street crossing in Allegheny City, about 6 p. m. Nov. 3, and two passengers who jumped from the car were caught under the wheels of the engine and ground to death. Their names were John M. Culp, teller of the Odd-Fellow's saving bank of this city, and Miss Harriet Weyman, a sister of Weyman Bros., tobacconists. No others were hurt. The accident was caused by the gateman, Stewart Cunningham, raising the safety-gates too soon.

#### RHODE ISLAND.

**Woonsocket.** On the evening of Nov. 19th, as the electric car was making its last trip up South Main street, a cross connection was made on the two trolley wires, caused by the insulation becoming wet by the rain, and the man in charge, not the regular engineer, not being aware that such a connection would be made, allowed the wires to become connected. One of the trolley wires was immediately burned off, and sparks from it ignited the canvas covering of the motor



underneath the car, and that was soon consumed. The car was immediately hauled off, and horse cars run the whole length of the line Sunday, much to the delight of the patrons of the road. An official of the road says that the car will be boxed up and then it will be run again.

#### TEXAS.

*Galveston.* The consolidation of the two street railway companies—the Galveston city and the Gulf city—is practically effected, although the two organizations will still remain separate. As a result of this consolidation several cars will be discontinued on both lines, in order to more thoroughly systematize the running of the combined system. Work will be commenced at once in changing the gauge of the Gulf city lines to conform to the Galveston city lines and several lines now running parallel will be changed to circuit lines. It is probable that this consolidation will result in a connection next spring between the popular terminal resorts of the two lines, Woolam's lake and the Beach, by a line of road extended from the lake around the beach to the Beach hotel.

#### WASHINGTON TERRITORY.

*Seattle.* The Seattle Cable Road and Water company will immediately commence the construction of a cable line by way of Madison street to Lake Washington. The cost of the road will be about \$60,000 a mile.

Within a few weeks work will also be begun by the Seattle Construction company on a cable road to the lake by way of Mills street, and return by Jackson street. This will provide the city with two cable lines, one with a circuit of six miles, and another with a circuit of four miles. The Madison street line proposes to erect a large summer hotel on the lake at the end of the line, and work will be begun in the spring.

#### WISCONSIN.

*Madison.* We are requested to state more fully what the president and vice-president of the Madison Street Railway company told the city council. They said: "Blood can not be got out of a turnip. The company from its inception have expended in operating the road about \$200 a month more than the receipts. One of the principal expenses is in repairing the street, which the city can keep in repair for one-quarter what it costs the company. The road can not exist if required to keep the street within its track or outside of it in order. The present requirements in this regard are the same as those required of street railway companies in Chicago and other large cities where the stocks are worth \$2,000 for \$100 of investment. Street cars have as much natural right to the streets as any other vehicle. The only reason for imposing conditions upon them is the presumption that the company can comply with them and still make a satisfactory profit. But if they can make no profit no conditions should be imposed, but the city should, on the contrary aid such enterprises in every reasonable way."

*Waukesha.* The Waukesha St. Ry. Co. has not yet gone further than organization.

#### CANADA.

##### ONTARIO.

*St. Catharines.* The St. C., Merrilton and Thorold Street Railway was opened October 8; it is nearly six miles long, and is operated by the Van Depoele system of electrical propulsion. It has "proved a perfect success in every particular; far exceeding the expectations of the managers," says our correspondent. The electricity which is generated by water power at lock 12, Welland canal by a 1,160 horse power dynamo, is conducted by overhead copper wires connecting with the cars by means of small wheels which run along on the wires and thence through a flexible conductor to the motor. The time of traveling between St. Catharines and Thorold has been reduced to twenty minutes. The cars are under perfect control, being stopped and started without any jerking motion, going around curves of forty degrees and up grades of 7 per cent, without the least difficulty.

#### Business Notes.

**FOR SALE.** The Ottumwa (Ia.) street railway is to be sold, on account of the proprietor's death. The line is a couple of miles long, all in good condition, and runs through the main streets of the city, which are either paved or macadamized. Ottumwa is a manufacturing and jobbing city of 14,000 inhabitants. In connection with the sale of this road, is offered the South Ottumwa & Cemetery lines, which can be profitably consolidated with the former line, making a complete system, and covering all available streets in the city. Franchises for both roads run about 25 years yet. These two roads, which are doing good business, will be sold at a very reasonable figure. Correspondence with E. E. Mc Elroy, administrator, or H. L. Hedrick, superintendent, Ottumwa, Ia.

The Car Track Friction Appliance company of 19 Tremont row, Boston, has received orders to equip four new electric roads, besides additional orders from Mount Adams & Eden Park Inclined Railway company, Cincinnati, Ohio; Metropolitan R. R., Kansas City; Kansas City Electric Railway company, etc. And they are making new contracts which will keep the company's works busy for some time to come.

The elegant cars on the Wyandotte (Kansas) cable extension of the Metropolitan Street Railway Co., Kansas City, Mo., were built by Pullman's Palace Car Co.

**SUPERINTENDENT WANTED.** Wanted a competent and practical Superintendent for horse power street railway. No one, unless perfectly familiar with all the details of the business, and who can furnish unquestionable references, need apply. Address "Superintendent", care of the STREET RAILWAY GAZETTE, 9 Lakeside Building, Chicago, Ill.

The Messier car brake, illustrated in our last issue, is manufactured by Mr. W. N. Lewis, 8 State Street, Albany, N. Y. Its shoes are guaranteed for a year. The Albany railway will use no other, as the Messier alone will stop a large car, filled with passengers, on a steep grade. In a recent issue of the Albany *Journal* was a report of one of the drivers refusing to take a heavy load down hill, and requesting the passengers to get out and walk down, as the brake might break, or at all events fail to control the loaded car. "The complaint was loud that the company should furnish better brakes, or else restrict the number of passengers to a car." They soon secured a better brake. And the Messier car brake works most admirably.

THOSE Veiled Prophets' parade at St. Louis did a lot of mischief in various ways—notwithstanding Prof. Swing's apology therefor, in the Chicago *Evening Journal*. The cars of the Cable company had been massed down town to carry off the overflow of people, thus throwing all of an enormous strain upon one end of the line. The result was the breaking of the 12-inch shaft at the power house, and the twisting and kinking of the cable viciously and instantly at several points. No less than six or seven kinks were formed in the massive rope; but when these were finally straightened out and the cable machinery started—ten days or two weeks after the mishap—it was found that the rope was quite as good and effective as before. It is now running smoothly, and fully and perfectly meeting all the requirements of the Cable company. What interests us in this connection is the fact that the cable was furnished the St. Louis Cable & Western railroad company by the Broderick & Bascom Rope company, and that it is working to the utmost satisfaction of all concerned. As an article of home manufacture it is an object of considerable interest, says the *Age of Steel*. This is all the more true because it is one of the largest and most powerful cables ever made. An idea of its size may be had when it is said that it is 35,000 feet, or nearly seven miles, long—made in a single piece. Its weight is 100,000 pounds. Immediately after being placed in the conduit it was subjected to an extraordinary test, made necessary by the immense pressure of traffic on the night of the Veiled Prophets' parade.

THE Lane & Bodley Co., Cincinnati, have supplied the driving machinery for the White Line (electric) Street Railway, at Dayton, O. A pair of engines are to drive three 80 h. p. dynamos, to be driven by clutch pulleys from the line shaft.

**PULLMAN PALACE CAR COMPANY**

Office of the President—Chicago, November 15th, 1887. *Executive order.* Mr. E. H. Goodman having tendered his resignation as second vice-president of this company, the same has been accepted to take effect this date. Correspondence relating to the Construction Department should be addressed to the General Manager, at Chicago.

GEO. M. PULLMAN, President.

AMONG the numerous exhibits at the exhibition by the Mechanics Charitable association in Boston, were R. T. White's Acme Girder, steel street railway road bed, an operating model of an electric railway having cars suspended, and a beautiful working model of a street car with the Baker brake.

MEIGS elevated railway is exhibited by model at 304 West Madison street, Chicago; and Capt. Joe V. Meigs has given descriptive and illustrated lectures thereon.

THE Riley Railway Construction company has some very exquisitely well made working models and handsomely illustrated catalogues, whereby the system is readily understood, at 93 Milk street, Boston.

PARTIES interested in the Baker brake, described and illustrated in this number of the GAZETTE, may address E. E. Baker and J. B. Allen, No. 53 Broadway, Cambridgeport, Mass.

BEMIS patent trucks and journal boxes are in great demand. The Pullman people use a great number thereof, in combination with the Vose graduated spring; and Cline's heaters and patent aromatic fuel make these "combination" cars very comfortable. Mr. Horace G. Bird, general agent of the Bemis Car Box Co. (426 Insurance Exchange, Chicago), desires us to correct a false report, circulated in the East, to the effect that the Bemis trucks are Pullman's patents; whereas the Bemis Co. are the

patenters and owners thereof, and the Pullman Co. are equipping numerous cars therewith; among other orders they are equipping twenty-five combination cars with double trucks for the Metropolitan St. Ry. Co., Kansas City, and a couple for the Citizens' Ry. Co., St. Louis.

THE Adams and Westlake Company (110 Ontario St., Chicago) have issued a new handsome catalogue describing and illustrating every class of lighting material required for the full equipment of a railroad, embracing lamps, lanterns and head lights; also globes, shades, burners, etc. There are six elegantly illustrated descriptions of street car center lamps; an end box lamp, and a bonnet lamp. The latter is designed to be used on the top of a bonnet or hood projecting over the platform of a street car; and by means of a large semaphore lense set to focus, with a reflector back of the flame, the rays of light are thrown on the track ahead of the horses. It is particularly serviceable on cars running in the outskirts of cities where the streets are not otherwise lighted.

A NATURAL inquiry anent the Baker brake is, how does it compare with those now in use? Its quick efficiency is certainly a very great advantage and a most commendable feature; its simplicity and mechanical arrangement are beyond all question; add to this that there are no more pieces and less wearing parts than in the ordinary street car brakes. Its application does not involve changes in trucks or the removal of wheels. It is a powerful, quick-acting, economical brake, adapted to horse cars, steam or electric motors; for cable roads, elevated roads of all kinds, as well as for steam railroads. In short, it is a brake that requires very little movement to tighten the bands on the discs; has great leverage and small expenditure of power.

EITHER the seats in the street cars should be divided up by arms, or the conductors should have orders to see that passengers do not take more room than they are entitled to. Nothing is more common than to see two or three persons deprived of seats, by the selfishness of passengers who don't or won't "move up."

# BENTLEY-KNIGHT ELECTRIC RAILWAY CO.,

## 115 BROADWAY, NEW YORK.

Contractors for the construction of City Street Railways and  
Suburban Tramways using either

# UNDERGROUND, SURFACE OR ELEVATED CONDUCTORS.

## ESTIMATES FURNISHED ON APPLICATION.

N. B.—The Bentley-Knight Electric Railway Company absolutely controls all efficient and economic methods of operating electrically equipped cars by means of conductors contained in and protected by sub-surface conduits. Entering the field long in advance of all others, it first encountered the many difficulties which had to be met and overcome; and the many patents now owned and controlled by it effectually cover each and every detail (both mechanical and electrical) necessary to the successful construction and operation of an electric railway in a city street.



# DIRECTORY SUPPLEMENT.

# The Street Railway Gazette.

VOL. II.

CHICAGO.

AUGUST, 1887.

NEW YORK.

No. 8.

## The RELIABLE SAND BOX.

OVER 400 NOW IN USE.



*The only Box that will run SALT or WET SAND and GRAVEL.*

Now is the time to fit up your Close Cars, owing to our rush of business.

Orders sent in now cannot possibly be filled inside from four to six weeks.

**W. T. BUTLER,**

General Manager,

19 Tremont Row,

BOSTON, MASS.

## THE BRYDEN FORGED HORSE-SHOE WORKS, LIMITED.

CATASAUQUA, PENN.

MANUFACTURERS OF

## The Bryden Forged Solid Calk HORSE AND MULE SHOE.

ADOPTED BY THE FOLLOWING STREET RAILWAYS :

*The Third Avenue R. R. Co., Eighth Avenue R. R. Co., Broadway & Seventh Avenue R. R. Co., of New York City; Bushwick R. R. Co., Brooklyn City and Newton R. R. Co., of Brooklyn; Philadelphia Traction Co., Citizen's Passenger R. R. Co., Second & Third Street R. R. Co., of Philadelphia; Metropolitan R. R. Co. of Washington, D. C.; North Chicago R. R. Co., Chicago City R. R. Co., West Division R. R. Co., of Chicago, Ill.; New Orleans City & Lake R.R., of New Orleans, La., etc. etc.*

**J. B. WHITE, MANAGER SALES DEPARTMENT,**

234 Lake Street, CHICAGO, ILLS.

# KUHLMANN CAR CO.

BUILDER OF

# STREET RAILWAY CARS

OF EVERY DESCRIPTION.

ALL KINDS OF WOOD WORK FOR INTERIORS A SPECIALTY.

Street Railway Companies building their own Cars will do well to correspond with us.

Office: 490 St. Clair Street, CLEVELAND, O.

# CLEVELAND FOUNDRY,

MANUFACTURERS OF

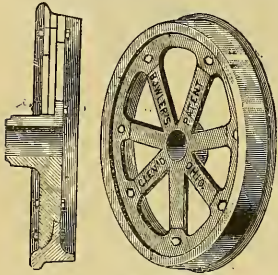

## Car and Locomotive Wheels,

*Either Chilled or Steel Tired, with or without axles.*

*Street Railway Wheels, Turnouts and Turntables, Patent Chilled Face R. R. Frogs, Engine and Heavy Castings a Specialty.*

GRADED STABLE GUTTERS WITH STRAIGHT OR CURVED COVER.

Descent 1/2 inch per foot. Pieces 5 feet lengths. Short pieces furnished to suit any length. Spouts to connect with sewer.

They control and make N. P. Bowler's Patent Street Railway Wheel. The tire of this wheel is cast separately from the hub and spokes; the latter is made of soft strong iron, and is perfectly free from strain—therefore can be made much lighter and more durable. The tires and the spokes or center of the wheel are made perfectly interchangeable so that when the tire or rim is worn out another can be put in its place by any employee with no other tool than a common wrench.

BOWLER & CO., 10 to 24 Winter St., CLEVELAND, OHIO.

# Use IRON CLAD PAINT

FOR YOUR CARS, BARNs AND BUILDINGS.

OFFICE OF EAST CLEVELAND RAILWAY CO.  
IRON CLAD PAINT CO.:

Gentlemen:—This Company, for the last 17 years, has extensively used your "Iron Clad Paint" upon its buildings, roofs and cars. For durability, protection against fire, and cheapness, there is no paint that will compare with it. It is equally as good for fine as for coarse work; it polishes beautifully. The paint upon the bodies of our cars which was put on ten years ago, is as firm and good as when first put on, while the other kinds of paint put on at the same time, has been renewed twice; nothing has been done to the Iron Clad except new coats of varnish.

EDWIN DUTY, Superintendent.  
WM. KRUEGER, Painter.

OFFICE OF THE MASTER CAR BUILDER,  
Toledo, Wabash & Western R'y.  
TOLEDO, O., Feb. 18, 1873.

IRON CLAD PAINT CO., Cleveland, O.:

Dear Sir:—In reply to your letter of the 9th inst., as to the use of the "Iron Clad Paint" by this Company, would say: That we have been using it for the past year on our passenger and baggage cars, and are very much pleased with it. We can cheerfully recommend it for its body, durability and cheapness. Accompanying this you will find a sample of the color we use on our coaches, which is obtained by grinding together 20 pounds of Rosie and one pound Lampblack.

Respectfully,  
U. H. KOHLER, M. C. B.

THE  
PUREST.  
THE MOST  
FIRE-PROOF.  
THE MOST  
DURABLE  
PAINT  
IN THE  
WORLD.



THE  
Cheapest.  
THE MOST  
Economical.  
THE MOST  
Water-Proof  
PAINT  
IN THE  
WORLD.

Trade Mark Patented—Paint Patent-d

Refer to East Cleveland Street Railway Company, who have used it for nearly Twenty Years.

# IRON CLAD PAINT COMPANY, - CLEVELAND, OHIO.

A Discount of 5 per cent to any one mentioning this Advertisement.





JOHN J. BRODERICK, Prest.

JOS. D. BASCOM, Sec. & Treas.

# Broderick & Bascom Rope Co.

Manufacturers



# ROPE

## Cable Ropes

FOR

### STREET RAILROADS.

# WIRE

St. Louis, Mo.

# The Horace A. Keefer Co., KANSAS CITY, MO.

## Street, Cable, Motor & Steam Railway

EQUIPMENT AND TRACK MATERIAL A SPECIALTY.

### PRICE'S IMPROVED FARE BOX.

THE BEST IN THE MARKET.

The ringing of a gong for each fare, checks the passenger as well as the driver, and hence conductor's bell punch is unnecessary.

It is positively the best fare collector in the *World*.

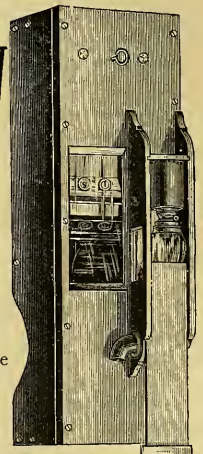
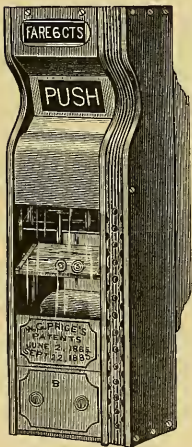

### Corliss Engines, Safety Boilers, Feed-Water Heaters, Pumps,

WINDING GEAR AND CABLE OUTFITS COMPLETE.

Can always secure our customers good bargains in second-hand Supplies and Equipments.





# FRANK H. ANDREWS,

SUCCESSOR TO

ANDREWS & CLOONEY, F. T. LERNED, Gen'l Agt.

MANUFACTURER AND CONTRACTOR FOR

## CONSTRUCTING STREET RAILWAYS.

THE BUILDING OF

# CABLE ROADS

AND FURNISHING MATERIALS FOR SAME, A SPECIALTY.

*All kinds of Steel and Steel Grooved Rails, Straight or Bent to any Radius. Knees, Fishplates, Spikes, Bolts, Etc., Etc.*

## MACHINERY:

*Wheel Presses, Wheel Borers, Axle, Lathes, Drills, Etc., either for Steam or Hand Power.*

PROMPTNESS AND REASONABLE PRICES.

SEND FOR ILLUSTRATED CATALOGUE.

BRANCH OFFICES:

**BOSTON,**

37 Central Street.

**ST. LOUIS,**

Southern Hotel.

**CHICAGO,**

Lakeside Building.

Represented in California by WM. B. ISAACS, 258 Market Street, San Francisco.







# The Caldwell Patent CONCRETE MIXER.

Patented September 26th, 1882.

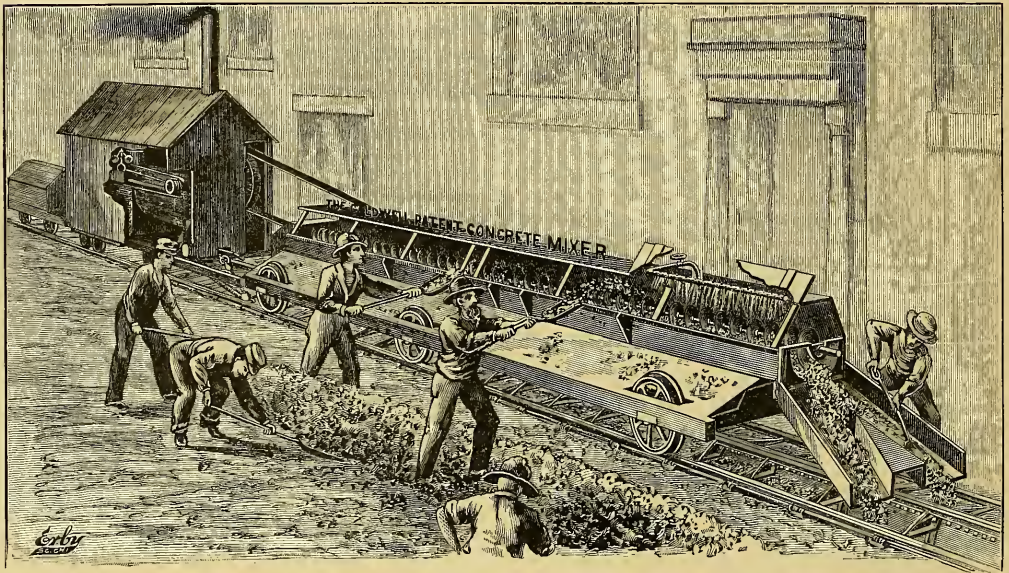

**Used by all the Principal Cable Roads in Constructing their Lines.**

**Saves Large per Centages, Makes Better Mixtures and Facilitates Progress.**

Used by Chicago, Cincinnati, Philadelphia, St. Louis, Pittsburgh, and other Cable Roads. Also, by many Bridge Builders, Railroads, Architects, and Prominent Engineers.

Sold with right to use—knocked-down or mounted, complete—by

## H. W. CALDWELL,

131 and 133 West Washington St., CHICAGO.







**Hochester** (93,866). \* Rochester City & Brighton RR. Co.—Pr Patrick Barry. Sec C. Wood. Spt Thos. J. Brower; 37 m, 37 1/2, 170 c, 632 ft.  
 Citizens' St. Ry. Co.—Pr Wm. H. Jones, Sec & Tr J. E. Pierpont.  
**Rome** (12,194). Rome City St. Ry. Co.—Pr Rowland F. Hill, Sec Wm. Moores, Engr Sam'l McCreery; 5 m.  
**Schenectady** (13,665). Sch. St. Ry. Co.  
**Stillwater** (877). Still & Mechanicsville St. Ry. Co.—Pr Wm. L. Denison, Sec Edward I. Smith, Engr Geo. W. Venable.  
**Syracuse** (51,792). Bienenstr. Ry. Co.—2 m, 47 c, 19, 43 ft.  
 Central City Ry. Co.—Pr Daniel Pratt, Sec James Barnes, Spt George Crampton; 2 1/2 m, 47 c, 19, 43 ft.  
 Fifth Ward St. RR. Co.—Pr P. B. Brayton, Sec Oliver C. Potter, Spt Hugh Furphy; 2 1/2 m, 50 lb, 10 c, 50 lb, 10 c.  
 Geddes St. RR. Co.—Pr Nelson Getch, Sec R. A. Bonta, Spt W. J. Hart; 1 1/2 m, Genesee & Water St. RR. Co.—Pr Robt. G. Wynkoop, Sec Geo. J. Gardner, Engr Wm. J. Hart; 5 m, 18 to 40 lb, 11 c, 38 lb, 4 1/2 c.  
 New Brighton & Albany RR. Co.—Pr M. Britton, Sec T. W. Meacham.  
 Spt A. G. Markham; 1 7/8 m, 4-8 lb, 10 to 35 lb; 2 c, 6 lb.  
 Seventh Ward Ry. Co. of Syracuse.—Pr Edw. F. Rice, Sec Edw. I. Rice, Spt Frank Churchill; 2 1/2 m, 47 c, 19, 43 ft.  
 Syracuse & Geddes Ry. Co.—Officials same as Geddes St. Ry. Co.; 2 1/2 m, 30 to 47 lb; 2 c, 35 lb.  
 Syracuse & Onondaga Ry. Co.—Pr P. Burns, Sec L. C. Smith, Spt W. B. Thompson; 2 1/2 m, 28 and 36 lb; 9 c, 20 lb.  
 Third Ward Ry. Co.—Pr C. C. Goodwell.  
**Troy** (56,747). Cortland & Homer Horse RR. Co.—Pr C. H. Garrison; 4 m, 25 and 30 lb, 3 c.  
 Troy & Albany Horse RR. Co.—Pr Thos. A. Koickerbocker, Sec T. E. Hazlehurst; Spt W. B. Bean; 3 3/8 m, 45 lb, 13 c, 50 lb.  
 \*Troy & Lansingburgh RR. Co. (205 River St.)—Pr Charles Clemenshaw, Sec Joseph J. Kelly, Engr Geo. W. Venable.  
**Utica** (38,915). \*Utica Belt Line St. RR. Co.—Pr Joshua Mather; 20 m, 32 c, 97 ft. The Utica & Mohawk RR. Co.—Pr James F. Mann, Sec Wm. E. Lewis, Spt Michael Leard; 47 m, 47 c, 11 1/2 m.  
 Utica, Clinton & Binghamton RR. Co.—Pr James I. Scollard, Sec Robt. S. Williams; 10 3/8 m, 35 and 55 lb; 14 c, operated by the U. Belt Line St. RR. Co.  
**Waterford** (1,898). Waterford RR. Co.—Pr J. Brodell, Sec G. C. Ormsby; 1 7/5 m, 45 lb; leased to the Troy & Lansingburgh RR. Co.  
**Watertown** (3,895). Seneca Falls & Watertown RR. Co.—Pr S. R. Welles, Sec & Tr A. G. Mercer; 4 m, 47 c, 19, 43 ft.  
**Yonkers** (18,892). Yonkers RR. Co.—Pr D. N. Staotou, Sec John F. Brennan; 5 m, 42 and 48 lb; 10 c, 70 lb.

**NORTH CAROLINA.**

**Charlotte** (7,094). Charl. St. Ry. Co. (P. O. Box 294).—Pr J. W. Rushton, Sec & Spt E. K. P. Osborne; 2 7/8 m, 5-8 1/2 lb, 13 c, 4, 6 lb, 14 mu.  
**Durham** (2,041). Durham Ry. Co.—Pr J. B. Blackwell, Sec R. D. Blackwell; 8 m, 16 lb, 16 c, 25 lb.  
**Raleigh** (9,355). The Ral. St. Ry. Co.—Pr W. Y. Turner, Sec R. T. Gray, Spt W. A. Wilson; 16 and 35 lb; 8 c, 4 lb, 38 mu.  
**Wilmington** (17,350). Wil. St. Ry. Co.—Pr Lieut. Gov. Stedman; 5 m.

**OHIO.**

(Members of the Ohio State Tramway Association have a prefixed.)  
**Akron** (16,512). Ak. St. Ry. Co.—Pr Ira M. Miller, Sec F. M. Atterholt, Spt J. T. Meilly; 2 m.  
**Ashland** (4,445). Ash. City RR.—John M. Stewart, owner; 4 m, 40 lb, 7 c, 60 lb, Bellaire (8,026). St. Ry. Co.—C. D. Haines, proprietor; 2 1/2 m, 3-6 lb, 25 lb; 6 c, 20 lb, 3 m.  
**Berea** (1,682). The Ber. St. RR. Co.—Pr C. D. Miller, Sec A. H. Pomeroy, Spt A. W. Bishop; 1 1/2 m, 3-6 lb, 25 lb; 7 c, 2 1/2 m.  
**Canton** (12,488). Canton Ry. Co.—Pr J. C. Seventh St.—Pr G. E. Cook, Sec John F. Clark, Spt O. L. Staotou; 4 1/2 m, 4 lb, 28 lb; 9 c, 58 lb.  
 The Lake Side St. RR. Co. (Summer road).  
**Chillicothe** (10,100). Chil. Co.—Pr P. Safford, Sec A. E. Wines, Spt E. H. McManis; 2 m, 3 lb, 16 lb; 7 c, 1 lb, 14 mu.  
**Cincinnati** (255,139). Cincinnati Incline Plane Ry. Co.—Pr Geo. A. Smith, Sec & Spt James M. Doherty; 6-5 m, 5-2 1/2 lb; 25 c, 140 lb.  
 The Columbia & Cin. St. RR. Co. (Franklin Park).—Pr C. H. Kilgour, Sec & Tr A. H. Meteor, Spt J. A. Morren; 3-3 1/2 m, 3 c, 35 lb; 7 c, 6 c, 6 m.  
 \*Mt. Adams & Eden Park Incline Ry. Co.—Pr G. B. Keppel, Sec J. B. Murdoch, Spt R. P. Alley, Engr H. M. Lane; 1 1/2 m (8 m being cable), 5-2 1/2 lb, 52 lb; 50 c, 150 lb, 40 c, 2 engines, 1,000 hp.  
 Mt. Auburn cable Ry. Co. (12th and Mt. Sts.)—Pr Henry Martin, Sec Wm. F. Irwin, Spt C. W. Thomas, Engr Worcester Hartford; 8 m, 5-2 1/2 lb; 20 c, 10 c, two cable engines 350 hp each; only one-half the road finished and in operation.  
 \*The Cincinnati St. Ry. Co. (n.w. cor. 5th and Walnut Sts.)—Pr John Kilgour, Sec James J. McHugh, Spt John Harris, Engr F. E. Weizenecker; 100 m, 5-2 1/2 lb, 30, 42 and 53 lb; 27 c, 150 to 1900 lb and mu.  
 The Price Hill Incline Plane Ry. Co.—Pr M. W. Oliver, Sec Geo. T. McDuffie, Spt & Engr Lewis E. McHugh; 3,200 ft., 6-6 lb, 60 lb; 4 c; four engines 500 hp (one plane is for passenger cars, the other for freight).  
**Cleveland** (160,146). \*Broadway and Newburgh St. RR. Co. (1373 Broadway).—Pr Jos. Stanton, Spt John J. Smith; 5 m, 4-8 lb, 11 c, 25 lb, 11 c, 25 lb.  
 \*East Cleveland RR. Co. (1154 Euclid Ave.)—Pr A. Everett, Sec H. A. Everett, Spt Edwin Dwyer; 21 m, 45 lbs; 123 c, 58 lb.  
 St. Clair St. Ry. Co. (Chas. Hathaway, GM & Tr Chas. Hathaway, Jr. Sec Alfred G. Hathaway, Spt W. S. Lynde; 10 m, 42 lbs, 38 c, 160 lb.  
 \*South Side St. RR. Co.—Officials same as the Brooklyn St. RR. Co.; 3 1/2 m, 3 g, 40 lb, 8 c, 4 lb, 38 mu.  
 \*Superior St. RR. Co.—Pr Frank E. Robinson, Sec & Spt J. H. Robinson, Jr.; 15 m, 42 lb, 46 c, 262 lb.  
 \*The Brooklyn St. RR. Co. (1301 Pearl St.)—Pr Tom L. Johnson, Sec J. B. Hoefner, Spt A. L. Johnson; 17 m, 52 lb; 82 c, 460 lb, 22 mu.  
 \*Woodland Ave. & West Side St. RR. Co.—Pr M. A. Hanna, Sec J. B. Hanna, Spt Geo. C. Muller; 42 m, 42 and 43 lb; 125 c, 600 lb, 30 mu.  
**Columbus** (51,647). \*Columbus Consolidated St. RR. Co. (12 N. High St.)—Pr A. Rodgers, Sec Edw. K. Stewart, Spt H. H. Atcherson; 24 m, 5-2 1/2 lb, 35 to 110 c, 100 c, 100 c.  
 The Gleadow & Green Lawn St. RR. Co.—Pr A. D. Rodgers, Sec R. R. Rickly, Spt Jonas Wain, Engr Wm. Willcox; 3 m, 4-6 lb, 23 lb; 1 c, 5, 20 lb.  
**Dayton** (48,882). Dayton RR. Co.—Pr J. B. Jones, Jr., Sec J. C. Pennington, Sec C. A. Grainger, Spt W. M. Anderson; 7,333 m, 4 m, 25 c, 59 lb, 40 mu.  
 Fifth St. Ry. Co.—Pr A. A. Thomas, Sec D. B. Corwin, Spt Wm. Davis; 7 m, 48 lb; 18 c, 60 lb.  
 \*Oakwood St. RR. Co.—Pr Chas. B. Olegg, Sec J. W. Perrine; 12 m, 38 lb, 14 c, 65 lb.  
 The Wayne & Fifth St. RR. Co.—Pr W. M. Shaw, Sec Eugene Waicher, Spt N. Routhanz; 4 1/2 m, 38 lb; 7 c, 20 lb.  
 The White Line St. RR. Co.—Pr Wm. Depoele electric system.  
**Hamilton** (12,122). Ham. Horse Car Co.—Pr James S. Giffen, Sec D. P. Carr, Spt Spt Lesse; J. C. Bigelow; 4 m, 3 g, 28 lb, 11 c, 11 c, 18 lb.  
**Lima** (7,967). Lima & Mt. Pleasant Ry. Co.—Pr C. C. Fanor, Sec F. L. Langan, Spt W. H. Rose; 4 m, 40 lb; 7 c, 7 m; electric engines (Van Depoele system) 75 hp.  
**Mansfield** (9,856). Mansfield Electric St. Ry. Co.—Pr Edw. Oathorn (New York, Sec C. E. McBride, Spt W. G. Root, Engr Knight Nettel; 6 1/2 m, 45 lb; 5 c, electric m. (Bart system) under cars.  
**Middletown** (8,500). Middletown St. RR. Co.—Pr C. F. Gannekel, Sec E. W. Gunkel, Spt T. C. Reed; 2 m, 5-8 g, 56 lb; 4 c, 6 lb.  
**Newark** (9,600). Newark City Ry. Co.—Pr Stephen G. Clarke (Chicago), Spt Byron E. Clarke, Spt J. A. Alford; 40 lb; 7 c, 20 lb.  
**Parsippany** (11,321). Par. St. Ry. Co.—Pr James Skelton, Sec & Spt Enoch Reed; 2 1/2 m, 3-8 lb, 18 lb; 8 c, 8 lb.  
**Parkersburg** (15,400). Park. St. Ry. Co.—Pr Chas. V. Olds, Sec A. C. Moss, Spt Clark Rude; 2 m, 27 and 30 lb; 7 c, 28 lb.  
**Springfield** (20,730). Springfield Citizens' St. RR. Co.—Pr D. W. Stroud, Sec F. S. Penfield, Spt W. M. Aulford; 20 lb, 30 lb; 32 c, 10 lb, 145 mu.  
**Steubenville** (12,093). Steu. St. Ry.—Haines Brothers, Sec & Spt Enoch Reed; 2 1/2 m, 3-8 lb, 18 lb; 8 c, 8 lb.  
**Toledo** (50,137). Toledo St. Ry. Co.—Pr J. H. Shepley (Cleveland), GM T. F. Shepley, Spt John J. Watson; 10 m, 3 g, 28 lb; 35 lb; 31 c, 103 lb.  
 \*The Central Pass. RR. Co. of Tol.—Pr F. E. Seagrave, Sec C. F. Parks, Spt Jos. Murphy; 10 lb, 17 c, 80 lb, 20 lb, 20 lb.  
 \*Toledo Consolidated St. Ry. Co. (52 Summit St.)—Pr John E. Bailey, Sec A. E. Laog, Spt John Gilmartin; 20 m, 42 lb, 10 c, 50 lb, 4 mu.  
**Youngstown** (18,380). Youngstown RR. Co.—Pr John E. Davis, Sec Alfred Smith, Spt Joseph Ould; 2 1/2 m, 3 g, 23 lb; 6 c, 18 lb.  
**Zanesville** (18,113). Z. & McMillin St. Ry. Co.—Pr F. M. Townsend, Sec W. C. Townsend; 3 m, 3 g, 35 lb; 12 c, 40 lb, 12 mu.

**Portland** (17,577). Multnomah St. Ry. Co. (294 Washington St.)—Pr A. N. King, Sec E. A. King, Spt W. Mitchell; 2 1/2 m, 3-8 g, 10 lb; 19 c, 65 lb.  
 Port. St. Ry. Co. (104 Fourth St.)—Pr Joseph Halladay, Spt & Sec C. K. Harbanger; 2 m, 3-5 g, 25 and 42 lb; 11 c, 44 lb.  
 Trask & Duane St. Ry. Co.—Officials same as above; 4 1/2 m, 5-2 g, 45 lbs; Sec D. W. Wakefield; 10 m, 3-6 g, 25 and 38 lb; 24 c, 100 lb.

**PENNSYLVANIA.**

**Allegheny** (78,682). Allegheny Rapid Transit Co.  
 \*Federal St. & Pleasant Valley Pass. Ry. Co.—Pr Wm. McCreery, Sec R. F. Ramsey, Spt J. W. Crozier; 5 1/2 m, 5-2 g, 45 lbs; 23 c, 90 lb, 76 mu.  
 Peoples Park Pass. Ry. Co.—Officials same as above; 4 1/2 m, 5-2 g, 45 lbs; 10 c, 40 lb, 26 mu.  
**Allentown** (18,063). All. Pass. Ry. Co.—Pr Samuel Lewis (508 Hamilton St.), Sec Allentown (18,063). All. Pass. Ry. Co.—Pr T. Brown; 3 m, 19 lb, 6 c, 22 lb.  
**Altoona** (19,710). The City Pass. Ry. Co.—Pr John F. Levan, Sec L. B. Reifeisder, Spt J. L. Richmond; 3 m, 5-2 g, 45 lbs; 27 lb, 15 mu.  
**Beaver Falls** (5,013). Beaver Falls Pass. Ry. Co.—Pr J. S. Knight, Sec & Tr J. F. Merriam, Spt L. A. Johnson; 3 1/2 m, 5-2 g, 38 lb; 9 c, 39 lb.  
**Bradford** (9,347). Brad. & Kendall RR. Co.—Pr Jas. Brodey, GM & Spt E. Farsous, Sec G. H. Oorb; 1-5 m, 38 lb; 3 c, 4 lb.  
**Carbondale** (7,714). Carb. & Jersey Electric Ry. Co.—Pr J. W. Aitkin, Sec & Tr A. J. Moore; 1 m, 40 lb; 3 c, electric.  
**Chester** (14,997). Chester St. Ry. Co. (1300 Edmont Ave.)—Pr E. Mitchell Corneil, Sec Wm. S. Blakely; 9 1/2 m, 5-2 g, 45 lb, 18 c, 80 m and mu.  
**Easton** (11,924). Easton, South East & West End Pass. Ry. Co.—Pr Henry A. Sage, Sec W. H. Cooley, Spt Eliza Burwell; 4 m, 5-2 1/2 g, 42 lb, 11 c, 36 lb.  
 **Erie** (27,787). Erie City Pass. Ry. Co.—Pr W. Reed, Sec L. J. Sternberg, Spt E. A. Moore; 1 m, 40 lb; 3 c, electric.  
**Harrisburg** (30,762). Har. City Pass. Ry. Co.—Pr Henry A. Kelker, Sec John T. Einsinger, Spt B. B. Reed; 6 1/2 m, 5-2 1/2 g, 42, 47 and 52 lb; 25 c, 75 lb.  
**East** (10,450). East Pass. Ry. Co.—Pr J. C. Hager, Sec Charles Dennis; 5 m, 14 c, 14 lb.  
**New Castle** (8,418). New Castle St. Ry. Co.—Sec H. S. Wallace.  
**Philadelphia** (247,170). Citizens' Pass. Ry. Co. (n.w. cor. 12th and Susquehanna Ave.)—Pr Chas. E. Ellis, Sec J. Q. Adams, Spt A. B. Scarborough; 10 1/2 m, 5-2 g, 47 lbs, 10 c, 470 lb. This company operates part of the Empire Pass. Ry. Co. (n.w. cor. 12th St. and Susquehanna Ave.)—Pr James McManis, Sec John Q. Adams; 8 1/2 m, 5-2 g, 47 lbs; leased, part to the Citizens' Co. and operated by the Philadelphia RR. Co. (2501 Kensington Ave.)—Pr John Nollis, Sec Thos. S. Harris, Spt T. Elwood Cox; 18 10 m, 5-2 g, 47 lb, 10 c, 450 lb.  
 Germantown Pass. Ry. Co.—Pr C. D. Ritchie, Sec L. S. Rushaw; 29 1/2 m, 5-2 1/2 g, 47 lb. Leased to the Peoples Park Ry. Co.  
**Hersheyville** (4,445). Fairmount Pass. Ry. Co. (4300 Lancaster Ave.)—Pr Chas. H. Laffery, Sec W. G. Foster; 11 m, 5-2 g, 45 to 45 lbs; 50 c, 100 lb.  
 Lehigh Ave. Ry. Co. (320 Walnut St.)—Pr Jos. T. Bunting, Sec & Tr J. MCK. Barton; 6 m, 60 lb.  
 \*Lombard & South Sts. Pass. Ry. Co. (25th and South Sts.)—Pr John B. Parsons, Sec Thos. C. Barr, Spt H. J. Fresh; 17 106 m, 5-2 g, 43 lb; 54 c, 304 lb.  
 \*Peoples Park Pass. Ry. Co. (n.w. cor. 12th and Susquehanna Ave.)—Pr E. J. Edwards, Sec J. Golden, Spt Chas. S. Whitting; 45 m, 5-2 g, 47 lb; 174 c, 1153 lb. This Co. operates the Germantown Pass. Ry. and The Green & Coates Sts. Phila. Pass. Ry. Phila. City Pass. Ry. Co. (202 Walnut place).—Pr Wm. W. Colker, Sec T. W. Pennington; 12-11 1/2 m, 5-2 g, 47 and 75 lb; 11 c, 708 lb. Leased to the West Phila. Pass. Ry. Co. (n.w. cor. 41st and Haverford Sts.)—Pr P. A. B. Videner, Sec D. W. Dickson, Spt James T. Gorman, Engr A. D. Whitton; 18 m, 5-2 1/2 g, 45 lb, 18 c, 90 lb.  
 \*Thirteenth & Fifteenth Sts. Pass. Ry. Co. (n. e. cor. 15th and Cumberland Sts.)—Pr J. M. Key, Sec Alex. Keenick, Spt Wm. V. Cooper; 14 m, 5-2 g, 43 lbs; 55 c, 520 lb.  
 \*Union Pass. Ry. Co. (423 Walnut St.)—Pr Wm. H. Kemble, Sec & Tr A. B. West Phila. Pass. Ry. Co. (n.w. cor. 41st and Haverford Sts.)—Pr P. A. B. Videner, Sec D. W. Dickson, Spt James T. Gorman, Engr A. D. Whitton; 18 m, 5-2 1/2 g, 45 lb, 18 c, 90 lb.  
 \*Pitts. & Wilkinsburg Pass. Ry. Co.—Pr Geo. I. Whiteley, Sec F. L. Stephenson, Spt R. G. Herron; 6 m, 5-2 1/2 g, 45 lb; 16 c, 96 lb.  
 \*Citizens' Pass. Ry. Co.—Pr John G. Holmes, Sec M. Gornly, Spt Murray Versey; 18 m, 5-2 1/2 g, 45 lb, 47 and 52 lb; 48 c, 346 lb. This Co. operates the Transverse Pass. Ry. Co. (n.w. cor. 12th and Susquehanna Ave.)—Pr Wm. J. Crozier; 4 1/2 m, 5-2 g, 45 lbs; 10 c, 40 lb, 26 mu. Leased to Federal St. & Pleasant Valley Pass. Ry. Co., Allegheny Pass. Ry. Co.—Pr Chas. Atwell, Sec & Tr Chas. Seibert, Spt James C. Cotton; 10 m, 5-2 1/2 g, 46 lb; 44 c, 261 lb.  
 \*Pitts. & Birmingham Pass. Ry. Co. (300 ft. and Carson St.)—Pr W. Patrick, Sec R. B. Adams, Spt J. M. Gorman; 4 m, 5-2 g, 47 lb; 25 c, 177 lb.  
 Pitts. & East End RR. Co.—Pr Wm. L. Chalfont.  
 Pitts. & McKees Rocks Pass. Ry. Co.—Pr Wm. J. Burns.  
 Pitts. Oakland & Liberty Pass. Ry. Co.—Pr Thos. Bigelow, GM & G. W. Elkins, Sec John G. Tragardh, Spt H. M. Cherry; 11 m, 5-4 1/2 g, 47 lb; 22 c, 160 lb.  
 \*Pitts. & Wilkinsburg St. Ry. Co.  
 Pitts. Union Pass. Ry. Co.—Pr Chas. Atwell, Sec Chas. Seibert, Spt James C. Cotton; 10 m, 5-2 1/2 g, 46 lb; 44 c, 261 lb.  
 Second Ave. Pass. Ry. Co. (Second Ave.)—Pr D. George Fawcett, Sec & Spt James F. Fawcett; 5 m, 5-2 1/2 g, 47 lb; 8 c, 40 lb.  
 South Side Pass. Ry. Co.—Pr D. G. Brickell, Sec W. T. Wallace, Spt W. M. Rosborough; 5 m, 5-2 1/2 g, 45 lb; 12 c (only 6 in use), 40 lb.  
 The Pitts. & West End Pass. Ry. Co.—Pr J. A. Reilly, Sec Thos. S. Bigelow, Spt W. S. Burdick; 10 m, 5-2 1/2 g, 45 lb; 10 c, 40 lb, 30 c, 106 lb.  
 The Tracton St. Ry. Co.—Thos. M. Bigelow.  
 The Transverse Pass. Ry. Co.—Pr C. L. Magee, Sec W. R. Ford, Spt M. Elliot; 18 m, 5-2 1/2 g, 45 lb, 18 c, 90 lb.  
 Williamsburg & East Liberty Ry. Co.—Pr E. J. Allen, Sec W. H. Allen; 3 m, 5-2 1/2 g, 45 lb, 18 c, 90 lb.  
**Pittston** (7,472). Pitt. St. Car.—Pr & Spt Isaac Everett, Sec E. W. Mulligan; 1 7/5 m, 45 lb, 18 c, 90 lb.  
**Pottsville** (13,253). People's Ry. Co.—Pr Thos. A. Reilly, Sec & Spt Wm. D. Pollard; 1 1/2 m, 16 c, 64 lb.  
**Reading** (43,273). Riklomen Ave. Pass. Ry. Co. (Perklomen Ave. & 19th St.)—Pr Chas. Brensler, Sec Isaac Hiestor, Spt John B. Houpp; 4 1/2 m, 5-2 1/2 g, 38 lbs and 45 lb; 18 c, 75 lb.  
 \*Reading City Pass. Ry. Co.—Pr Benj. F. Owen, Sec H. A. Muhlenberg, Spt J. A. Riggs; 2 1/2 m, 5-2 g, 45 lb; 22 c, 56 lb.  
**Scranton** (22,222). Scranton St. Ry. Co.—Pr T. H. Elmer.  
**Snyder** (45,458). Snyder Pass. Ry. Co.—Pr Geo. Wm. Mathews, Sec Horace E. Hand, Spt F. Pearce; 10 m, 25, 40 and 52 lb; 10 c, 90 lb.  
 Spt. Suburban Ry. Co.—Pr Edw. W. Stanger, Sec G. Sanderson, Spt R. F. Kilsner; 4 m, 4 c, 25, 40 and 52 lb; 10 c, 90 lb.  
 The Transverse Pass. Ry. Co.—Pr G. Clark, Sec T. C. Saow; 5 m.  
**Stroudsburg** (1,860). Stron. Pass. Ry. Co.—Pr Spt & Tr J. Lantz, Sec Jacob Houser; 1 1/2 m, 28 and 30 lb; 7 c, 7 lb, 3 mu.





# CAR HEATING

WITH CLINE'S PATENT HEATER AND

## Aromatic Carbonic Compound Composition Fuel



CHEAP. CONVENIENT. SAFE.

Once Filling lasts 18 hours.

NO CUTTING OF CAR TO PUT IN.

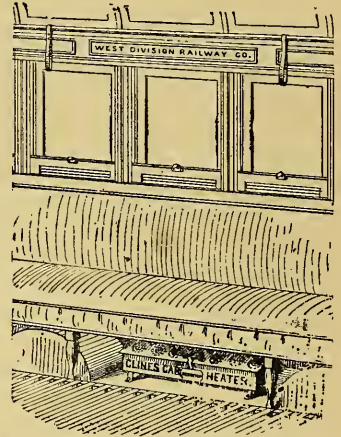
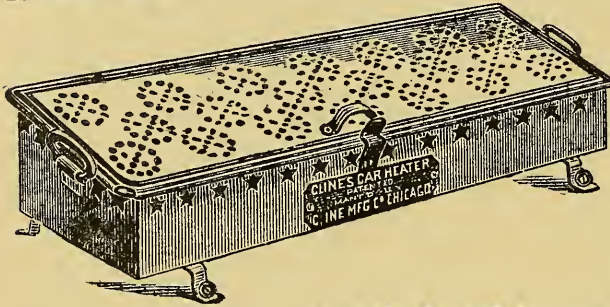

### ADOPTED BY THE FOLLOWING ROADS:

Office of THE CHICAGO FIRE UNDERWRITERS' ASSO.,  
157 to 163 LaSalle Street, Rooms 31 & 33.  
T. A. BOWDEN, Sup't of Surveys.  
D. C. Cregier, Sup't West Div. Railway Co.

Chicago, Ill., Oct. 28, 1886.

Dear Sir—I have examined into the Cline Manufacturing Co's Heater, also Cline's Aromatic, Carbonic, Composition Fuel, and I see no reason why you should not put them in the cars, provided they are securely fastened down to the floor; and when fire is applied to them it should be carried around in a metal can, and a small shovelful dropped into the stationary heater when in the car. Also in no case should there be hay in the car when the heater is fired up. Yours truly,  
T. A. BOWDEN, Sup't of Surveys.

### CHICAGO WEST DIVISION RAILWAY COMPANY.

Office of the Sup't, DEWITT C. CREGIER.

To whom it may concern.

Chicago, Jan. 21, 1887.

This is to certify that this company has in use over 200 Cline's Heaters in their cars. Respectfully, DEWITT C. CREGIER, Supt.

### SOUTH CHICAGO CITY RAILWAY CO.,

Room 46 Calumet Bl'd'g, 191 LaSalle St.

Messrs. L. Cline & Bro., Chicago.

Chicago, Feb. 8, 1887.

Gentlemen:—We have used your Heaters in our cars since the first of December last, and have found them entirely satisfactory. During the coldest weather the temperature in the cars has been maintained at about 45 degrees. We cheerfully recommend the Cline Heater to other street railroads.

D. S. TAYLOR, Pres't.

W. H. HARTMAN, Pres't.

T. N. KELLOGG, Sec'y & Treas

J. A. FOYE, Vice Pres't & Sup't

Office of WATERLOO STREET RAILWAY CO.,

Cline Mfg. Co., Chicago.

Waterloo, Iowa, Feb. 5, 1887.

Gents:—We are just testing your Heaters. We are well pleased with the results thus far. There is no question but that two of them will heat a 12 foot street car when the mercury is "way down" below zero. I think you have at last solved a "long felt want." Very respectfully yours,  
Waterloo Street Railway Co., by W. HARTMAN.

W. S. ROBINSON, Pres't.  
D. C. KELLOGG, Vice Pres't.

Office of CITY OMNIBUS COMPANY,

68 South Canal Street,

F. R. HITT, Sec. & Treas.  
S. J. RUSSELL, Supt.

Chicago, Feb. 5, 1887.

Gentlemen:—We are using the Cline Manufacturing Company's Heater and Fuel this winter in our Omnibuses, and find it makes one-half difference in the increase of the travel. I would recommend it to any Omnibus or Car Company, as they will never do without it if they use it once. We could not get along without it and cheerfully recommend it to the public. Respectfully,  
S. J. RUSSELL, Supt.

### R. PATRICK & CO., BANKERS.

Cline Mfg. Co., Chicago.

Pittsburg, Feb. 12, 1887.

Dear Sir:—We have in use on the Pittsburgh and Birmingham Passenger R. R. cars, the Cline & Bro. Patent Heater and Fuel. Having used the same for the past two months they have given us entire satisfaction and contributed to the comfort and pleasure of our patrons. Respectfully,  
W. W. PATRICK, Pres't.

### President's Office, RICHMOND CITY RAILROAD,

J. C. SHAFFER, Pres't.

Cline Mfg. Co., Chicago, Ill.

Richmond, Ind., Feb. 28, 1887.

Gents:—Your favor of Feb. 28 received and noted. We used your heater such a short time that we hardly feel competent to speak about its value. It gave satisfaction during the time it was in use. Next winter we will give it a more thorough test. Yours truly,  
J. C. SHAFFER.

### CHICAGO WEST DIVISION RAILWAY COMPANY,

Office of the Superintendent.

DEWITT C. CREGIER, Supt.

To whom it may concern:

Chicago, July 21, 1887.

The Cline Car Heater was placed on a number of the cars of this company during last winter, giving good results so far as known. DEWITT C. CREGIER, Supt.

# Cline Manufacturing Company,

277 & 279 S. CANAL ST., CHICAGO, ILL.







**Crefeld** (73,866). †Crefeld-Merding Street Ry.—Spt (of construction) Hossfeld; 1,775 m; 9 c, 27 h.  
**Danzig** (114,000). †Danzig Tramway Ry.—Dir Oscar Kupferschmidt; 5,783 m; 27 c, 75 h.  
**Dresden** (225,000). Dresden Tramway Co. of Germany (office London).—Dir G. M. P. Claus; 74.52 m; 102 c, 565 h.  
**Duesseldorf** (95,000). †Duesseldorf Tramway Co. (office Brussels).—Dir J. H. Mueller; 6,831 m; 28 c, 53 h.  
**Engelsdorf** (15,000). Engelsdorf Tramway.—Proprietor H. Reuss; 2.2 m; 7 c, 17 h. (Carries freight and passengers.)  
**Erfurt** (53,229). Erfurt St. Ry. Stock Co.—Dir E. von Dalievitz; 6.21 m; 20 c, 68 h.  
**Frankfurt** (176,000). †Fleussburg Tramway Co.—Dir G. Behringer (Frankfort-on-Main); 13.25 m; 84 c, 161 h.  
**Goerlitz** (53,000). Goerlitz Street Ry. Co.—Dir C. Nicolai; 4.4 m; 11 c, 38 h.  
**Hagen** (34,335). Hagen St. Ry. Co.—Dir Alex. von Stuelpnel; 4,968 m; 7 c, 28 h.  
**Halle** (90,000). †Halle St. Ry. Stock Co.—Dir Gade; 4,347 m; 20 c, 69 h.  
**Hamburg** (389,859). †Hamburg St. Ry. Co.—Dir J. A. Culin; 62.291 m; 244 c, 912 h, 19 stn. nr.  
**Hannover** (122,860). Hannover Tramway Co. of Germany.—Dir C. W. Gordon; 18.525 m; 63 c, 189 h.  
**Hanover-Vorort** St. Ry. Co.—Dir & Engr Honsinger von Waldegg; 2,173 m; 2 c, 5 h.  
**Karlsruher** (60,000). United Steam & Horse Ry. Co. of Karlsruhe, Muehlburg and Durlach; Receivers Hneck & Herm-Schmidt; 18 m.  
**Kiel** (44,000). Kiel St. Ry. Co.—1,525 m.  
**Koenigsberg** (141,000). †Koenigsberg Horse Ry. Co.—Dir Scheidel; 9,342 m; 76 c, 151 h.  
**Leipzig** (149,081). †Leipzig Tramways Co. (Lim.)—General direction, London.—Dir Engr Becken-Reinditz; 21.5 m; 92 c, 512 h.  
**Luebeck** (51,000). Luebeck Horse Ry. Co.—Bus Metz Dohrn; 5,247 m; 16 c, 62 h.  
**Magdeburg** (97,539). Magdeburg St. Ry. Co.—Dir Kitzling; 10,246 m; 40 c, 175 h.  
**Mayence** (90,000). Mayence St. Ry. Stock Co.—Dir Fr. Schmanski; 5,589 m; 20 c, 100 h.  
**Mannheim** (68,000). Mannheim Ludwigshafen Tramway.—Dir Emil Reitzschel, Mannheim; 57.07 m; 17 c, 49 h.  
**Mecklenburg** (42,000). Mecklenburg St. Ry. Stock Co. of Rostock and Schwerin.—Dir Oscar Otto, Berlin; 4,968, 2,484 m; 17 c, 52 h.  
**Metz** (53,107). †Metz Soc. Anon. des Tramways de Metz (Anonymous Assn. of Metz Tramways).—Dir C. W. Bohm; 7,762 m; 20 c, 70 h.  
**Munich** (230,023). †Munich Tramway Stock Co.—Dir E. Graziadei; 33,584 m; 135 c, 320 h.  
**Nurnberg** (138,000). †Nurnberg-Fuerth St. Ry. Co.—Engr & Dir Roth; 15,587 m; 46 c, 150 h.  
**Posen** (65,000). Posen Horse Ry. Co.—Dir Reimer; 3,632 m; 20 c, 54 h.  
**Potsdam** (48,000). Potsdam St. Ry. Co.—Dir Emil Bauer; 4,781 m; 29 c, 60 h.  
**Pyrmont** (1,500). Pyrmont St. Ry. Stock Co.—Ard G. Steinmeyer; 2,484 m; 5 c, 12 h.  
**Sofia** (110,000). Sofia St. Ry. Co.—Dir Alb. Kitzing; 3,154 m; 22 c, 122 h.  
**Strasburg** (111,000). †Strasburg St. Ry. Co.—Engr & Dir Alfred Noerlic; 16,17 m; 36 c, 20 stn. nr.  
**Stuttgart** (117,000). Stuttgart Horse Ry. Co.—Dir George Dielke; 6,392 m; 39 c, 82 h.  
**Fornesch** (5,000). Fornesch-Netersen Horse Ry. (City of Netersen, Holstein).—3,105 m; 4 c.  
**Wiesbaden** (56,000). †Wiesbaden Horse Ry. Co.—Dir Voss; 2,40 m; 12 c, 27 h.

**AUSTRIA-HUNGARY.**

**Arad** (33,000). Arad St. Ry. Co.—Dir Ludwig Deuner; 8,456 m; 14 c, 20 h.  
**Buda** (5,847). Buda Tramway Co.—Engr W. Fedeser; Buda near Vienna.  
**Buda** (300,000). Buda-Pesth St. Ry. Co.—Dir Henri Jelinek; 45,357 m; 278 c, 940 h.  
**Graz** (93,000). Graz Tramway.—Dir Jacob Markbreiter; 7 m; 20 c.  
**Lemberg** (104,000). Lemberg Tramway.—Dir Julius Schuster; 15 m; 26 c, 116 h.  
**Linze** (50,000). Linze Tramway.—Dir L. Ph. Schmidt; 7 m; 16 c, 25 h.  
**Pest** (10,000). Pest-Palota St. Ry.—2,740 m; 12 c, 122 h.  
**Prague** (196,000). †Prague Tramway.—Dir Constant de Preter; 22,649 m; 85 c, 407 h.  
**Temesvar** (33,000). Temesvar St. Ry. Co.—Engr Heinrich Boudier; 6,006 m; 21 c, 69 h.  
**Trieste** (127,000). †Trieste Tramway Co.—Dir J. Fanta; 59.3 m; 561 c, 1,921 h.  
**Vienna** (1,029,770). New Vienna Tramway Co.—Engr A. Pastorelli; 21 m; 66 c, 160 h.

**NETHERLANDS.**

**Amsterdam** (370,000). Amsterdam Omnibus Co.—Dir K. H. Sebodd; 12,839 m; 178 c, 600 h.  
**Arnhem** (42,000). Arnhem Tramway Co.—16 c, 62 h.  
**Breda** (29,000). Breda Tramway.—C. Kuipers; 3 c, 6 h.  
**Ginneken-Breda** (23,000). Ginneken-Breda Tramway Co.—Dir M. A. Kuyten-brouwer; 2,446 m; 6 c, 10 h.  
**Groninger** (—). Groninger Tramway Co.—Vandam; 1.7 m; 13 c, 39 h.  
**Groningue** (40,000). Soc Anon. des Tramways de Groningue; 3,042 m; 7 c, 16 h.  
**Hague** (157,000). Hague Tramway.—Dir E. Billen; 2,429 m; 82 c, 280 h.  
**Haarlem** (37,000). Haarlem Tramway Co.—Dir J. H. Van West, Jr.; 1.1 m; 10 c, 10 h.  
**Leyden** (42,000). Leyden Tramway Co. (office, London).—Dir Fryman, s'Gravenhage; 10c, 10 h.  
**Sluistsche** Tramway Co. of Utrecht; Dir W. J. Visser; 7,327 m; 14 c, 45 h.  
**Rotterdam** (152,517). Rotterdam, Hildersberg, Schieland Tramway Co.—Dir H. F. Schomens; 2,690 m; 6 c, 20 h.  
**Rotterdam** Tramway Co.—Dir H. F. Ginchart; 11.40 m, 40 c, 206 h.  
**Zeist-Drieboer** (Dosterstoom) Tramway.—W. J. Visser (Utrecht); 3 c, 5h.  
**Utrecht** (69,667). Netherlands Tramway Co. of Utrecht.—Dir S. Hamelink; 50.3 m; 24 c, 10 h.

**SWITZERLAND.**

**Basle** (62,000). Basle Tramway Co.—Promotor J. Seftelme; Sr. 60 h.  
**Genève** (48,793). Comp. Gen. of Swiss Tramways; Engr L. Laval; 31,988 m; 51 c, 162 h, 1 stn. nr.  
**Boetzengen-Riel-Nyden** (13,000). Tramway Co.—Engr T. Laval; 2,949 m; 7 c, 15 h.  
**Zurich** (21,189). Zurich St. Ry. Stock Co.—GM Th. Buhn; 7,415 m; 30 c, 104 h.

**BELGIUM.**

**Anvers** (—). †National Tramways of Anvers.—Dir Vander Meerem.  
 †Tramways of South Anvers.—Dir Galiers.  
**Brussels** (389,782). †Tramways of Brussels.—Dir H. G. Michelet, Engr F. Nonnenbery, Chief of technical service.  
 †General Company of Railway.—Dir de Backer.  
 †Company of secondary Ry.—Dir A. Focquet, Engr A. Spee.

**FRANCE.**

**Reims** (81,328). †Tramways of Reims.—Dir E. Thomas.  
**Rouen** (104,902). Rouen Tramways Co. (56 Rue Beauvoisine, Rouen).—38 c, 155 h.  
 7,116 shares (500 francs each) of the Compagnie des Tramways de Rouen are held by the Tramways Company of France, Limited (11 Old Jury Chambers, E. C., London).

**ITALY.**

**Brescia** (38,906). †Tramways of Brescia.—Engr A. Spee (Brussels).  
**Milan** (295,343). The City Road Railway Co., Lim. (4 Cornhill Building, E. C. London, Eng., and 42 via Carlo Farini, Milan); 75 kl; 45c, 54 wagons.

**NORWAY.**

**Christiania** (134,155). Tramways of Christiania.—Dir M. Vogt.

**RUSSIA.**

**Kharkoff** (—). The Tramways of Kharkoff.—W. Hammelrath, Sec of Administration, Brussels.  
**Moscow** (—). The Tramways of Moscow and Russia.—Sec Mr. Hammelrath.  
**Odessa** (—). The Tramway of Odessa.—Engr M. Boursion, Brussels.  
**Warsaw** (—).—Dir de Backer, Brussels.

**SPAIN.**

**Madrid** (397,861). Madrid St. Tramways.—Owned by the Tramways Union Co. Lim., London.—6.5 m; 55 c, 297 h.

**ROMANIA.**

**Bucharest** (321,505). Bucharest Tramways.—Owned by the Tramways Union Co. Lim., London.—Sec J. E. Walker, GM G. W. Webb; 10.5 m; 42 c, 169 h.

**INDIA.**

**Calcutta** (871,504). The Calcutta Tramways Co., Lim. (11 Abchurch Lane, E. C., London, Eng.)—Chr E. C. Morgan, Sec Chas. Akers, Engr Geo. Hopkiss, C.E.; Managing agent in Calcutta J. R. Maples; 18.5 m, 150 c, 662 h, 9 stn. nr.

**GUERNSEY.**

The Guernsey Steam Tramway Co., Lim. (57 Moorgate St., E. C. London).—Chr Rev. H. P. M. Dodington, Sec & Engr W. Gumbly; 4 m; 9 c, 6 stn. nr.

**AUSTRALIA. NEW SOUTH WALES.**

**Melbourne** (280,836). The Melbourne Tr. Co.—Engr G. Ducans; 34 m (10 m cable road in operation).  
**Sydney** (222,133). The Sydney Cable Tr. Co.—3.5 m (cable).

**CHEAPEST HOUSE IN THE WORLD**

FOR ALL KINDS OF

**Engineers' Instruments**

— FOR THE —

**Survey of Cable and other Street Railways.**

Transits, Levels, Rods, Chains, Tapes, Plumb-bobs, Etc., a Specialty.

**Aloe's New Model Transit,**

Especially adapted for Street Railway Work.

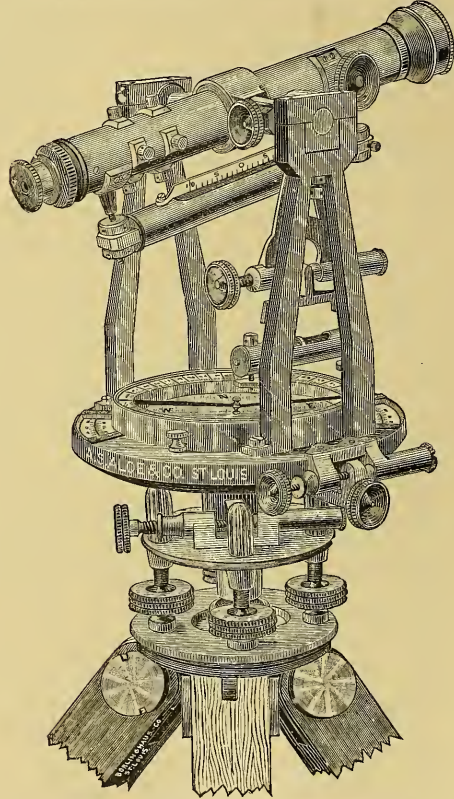

**PLAIN:**—With level and clamp, with level, clamp and quadrant, or with level, clamp and tangent, with full vertical circle. Cheapest and most desirable instrument ever offered to Engineers.

Also, Blue Print Paper, Mathematical and Drawing Instruments, Drawing Paper, Boards, Pins, Etc. Paints, Brushes, Palettes, Etc. Curves, Pencils, India Ink, Rules, Ellipses, Engineers' Alphabets, Protractors, Compasses, Sextants, and everything for use either in the field or draughting room.

**A. S. ALOE & CO.,**

300 North 4th Street, - - - ST. LOUIS, MO.



# TRADE DIRECTORY.

CORRECTED MONTHLY.

**AMBULANCE CARS (For Horses).**  
**BROOKLYN RAILWAY SUPPLY CO.** (The), 44 Water-st., Brooklyn, N. Y.

**AXLES.**  
**ANDREWS, FRANK H.**, 545 W. 33rd st., New York (ride Brackets).

**BALTIMORE CAR WHEEL CO.** (The), Fulton Junction, Baltimore, Md., U. S. A. (Agents—W. S. Meyersberg & Co., Chicago and St. Louis; W. S. Grant Baker, care of Brown Shipley & Co., Louthbury, E. C., London, England).

**BESS'S CAR WHEEL CO.**, Springfield, Mass.  
**HOWLER & CO.**, Cleveland, Ohio.  
**BRIH (G. G.) Co.**, Philadelphia.  
**BROWNELL & WIGHT CAR CO.**, 2300 Broadway, St. Louis, Mo.

**Cambria Iron Co.**, 218 S. Fourth st., Philadelphia; works at Johnstown, Pa. (Branches—No. 18 Wall st., New York; Montank Block, Chicago, Ill.)  
**Carriage, Phipps & Co.**, Limited, 48 Fifth ave., Pittsburgh, Pa.

**FULTON FOUNDRY** (S. M. Carpenter, proprietor), 202 Merwin st., Cleveland, O. (Agent—Thos. C. White, 107 S. 8th st., St. Louis, Mo.)  
**Griffin Wheel & Foundry Co.**, Robey st. and Blue Island ave., Chicago, Ill.

**Howard, Childs & Co.**, Hamilton Building (rooms 607 and 608) Pittsburgh, Pa.  
**Laclede Car Co.**, 4500 N. Second st., St. Louis, Mo.  
**LEWIS & FOWLER MANUFACTURING CO.** (The), 27 to 35 Walworth st., Brooklyn, N. Y.

**Pennsylvania Steel Co.**, 208 S. 4th st., Philadelphia. (Works at Weston, Dauphin Co., Pa.)  
**PUGH & RUSSELL**, Stewart Bldg., New York; Phoenix Bldg., Chicago, Ill.

**STREET RAILWAY SUPPLY CO.**, Cleveland, Ohio.  
**WHITNEY, A., & SONS**, Philadelphia, Pa.

**BARRIED WIRE.**  
**Cambria Iron Co.**, 218 S. 4th st., Philadelphia (ride Axles).

**BEARINGS.**  
**ADAMS & WESTLAKE CO.** (The), 110 Ontario st., Chicago; 115 Broadway, New York.  
**Ajax Metal Co.** (The), 2040 N. Tent st., Philadelphia.  
**American Bronze Works**, 46 Columbus st., Cleveland, O.  
**ANDREWS, FRANK H.**, 545 W. 33rd st., New York (ride Brackets).

**BALTIMORE CAR WHEEL CO.** (The), Baltimore, Md. (ride Axles).  
**BESS'S CAR WHEEL CO.**, Springfield, Mass.  
**BRIH (G. G.) Co.**, Philadelphia.  
**BROWNELL & WIGHT CAR CO.**, 2300 Broadway, St. Louis, Mo.

**Chapin Manufacturing Co.**, 69 Wall st., New York.  
**Danacrus Bronze Co.**, Pittsburgh, Pa.  
**FULTON FOUNDRY**, Cleveland, O. (ride Axles).  
**Greely** (The) E. S. & Co., 5 and 7 Day st., New York.  
**Keystone Smelting Co.** (The) Limited, 33d st., Pittsburgh, Pa.

**Laclede Car Co.**, 4500 N. Second st., St. Louis, Mo.  
**LEWIS & FOWLER MANUFACTURING CO.** (The), 27 to 35 Walworth st., Brooklyn, N. Y.

**MARTIN, RUFUS, & CO.**, 13 Park Row, New York (Branch—Wichita Construction and Supply Co., Wichita, Kan.)  
**Menely Geo. R. & Co.**, West Troy, N. Y. (Branch—Atlanta, Ga.)

**Miller Chas. B.**, 310 E. 14th st., New York.  
**Phosphor Bronze Smelting Co.** (The), Limited, 512 Arch st., Philadelphia.  
**Post & Company**, Cincinnati, Ohio.  
**PUGH & RUSSELL**, Stewart Bldg., New York; Phoenix Bldg., Chicago, Ill.

**STEPHENSON (JOHN) COMPANY**, Lima, New York, Stewart & Mattison Manufacturing Co. (The), 2042 N. 10th st., Philadelphia.  
**STREET RAILWAY SUPPLY CO.**, Cleveland, Ohio.  
**Thayer F. W. & Co.**, 428 Fowler st., Milwaukee, Wis.  
**Trial Smelting Works**, 760 S. Broad st., Philadelphia.  
**White Edwards & Co.**, 531 W. 33d st., New York.

**BELLS.**  
**Post & Co.**, Cincinnati, O.  
**VanDuzen & Tift**, 102 and 104 E. Second st., Cincinnati.

**BELTING.**  
**Page Belting Co.**, Concord, N. H. (Branches—19 Federal st., Boston; 111 Liberty st., New York; 161 Lake st., Chicago; 8th and St. Charles st., St. Louis, Mo.; 1307 W. 14th st., Kansas City, Mo.)  
**Schultz Belting Co.**, 60 W. Moore st., Chicago; Jas. Garnett, Philadelphia; Frank Pelree, Boston, Mass.)

**BLINDING MACHINES.**  
**Avery**, Abraham, 302 E. 17th st., New York.  
**BROOKLYN RAILWAY SUPPLY CO.** (The), 44 Water-st., Brooklyn, N. Y.  
**Cheer Steel Castings Co.**, 407 Library st., Philadelphia. (Works—Chester, Pa.)

**Craig Wm. P.**, 95 Liberty st., New York.  
**Greely** (The) E. S. & Co., 5 and 7 Day st., New York  
**Harris T. Wm. & Co.**, 2 Nassau st. (room 17), New York.  
**Howard, Childs & Co.**, Hamilton Building, Pittsburgh.  
**LEWIS & FOWLER MANUFACTURING CO.** (The), 27 to 35 Walworth st., Brooklyn, N. Y.

**MARTIN, RUFUS, & CO.**, 13 Park Row, New York (ride Bearings).  
**PUGH & RUSSELL**, Stewart Bldg., New York; Phoenix Bldg., Chicago, Ill.  
**Wm. Wharton, Jr. & Co.** (Incorporated), 25th st. and Washington ave., Philadelphia, Pa.

**BRACES.**  
**JOHNSON STEEL STREET RAIL CO.** (The), Johnsonstown, Pa. (ride Cable Yokes).  
**DICKSON C. H.**, Sec'y Northern Central Ry. Co., St. Louis, Mo.

**BRAKE CHAINS.**  
**ROLLINGS' CO.**, JOHN A. 117 and 119 Liberty st., New York

**BRAKE HANDLES (Patent Ratchet).**  
**Brih (G. G.) Co.**, Philadelphia.

**BRAKE RODS.**  
**Brih (G. G.) Co.**, Philadelphia.  
**BROWNELL & WIGHT CAR CO.**, 2300 Broadway, St. Louis, Mo.  
**Howard, Childs & Co.**, Hamilton Building, Pittsburgh.  
**Laclede Car Co.**, 4500 N. Second st., St. Louis, Mo.  
**LEWIS & FOWLER MFG CO.** (The), 27 to 35 Walworth st., Brooklyn, N. Y.

**MARTIN, RUFUS, & CO.**, 13 Park Row, New York (ride Bearings).  
**PUGH & RUSSELL**, Stewart Bldg., New York; Phoenix Bldg., Chicago, Ill.

**BRACKS.**  
**ANDREWS, FRANK H.**, 545 W. 33rd st., New York (Works—255 to 551 West 33rd st.; 529 to 552 W. 34th st., New York. Branches—37 Central st., Boston; Lakeside Building, Chicago; Southern Hotel, St. Louis. Agents—Wm. P. Craig, 258 Market st., San Francisco, Cal.; Bacon Biron, 377 St. Paul st., Montreal, Can.)  
**Brih (G. G.) Co.**, Philadelphia.  
**BROWNELL & WIGHT CAR CO.**, 2300 Broadway, St. Louis, Mo.

**Greely** (The) E. S. & Co., 5 and 7 Day st., New York.  
**Howard, Childs & Co.**, Hamilton Building, Pittsburgh.  
**Laclede Car Co.**, 4500 N. Second st., St. Louis, Mo.  
**LEWIS & FOWLER MFG. CO.** (The), 27 to 35 Walworth st., Brooklyn, N. Y.

**MARTIN, RUFUS, & CO.**, 13 Park Row, New York (ride Bearings).  
**PUGH & RUSSELL**, Stewart Bldg., New York; Phoenix Bldg., Chicago, Ill.

**BRACE SHOES.**  
**ANDREWS, FRANK H.**, 545 W. 33rd st., New York (ride Brakes).  
**Avery, Abraham**, 502 to 518 W. 45th st., New York.  
**Brih (G. G.) Co.**, Philadelphia.  
**BROWNELL & WIGHT CAR CO.** (The), Baltimore, Md. (ride Axles).

**Chester Steel Castings Co.**, 407 Library st., Philadelphia.  
**FULTON FOUNDRY**, Cleveland, Ohio (ride Axles).  
**Greely** (The) E. S. & Co., 5 and 7 Day st., New York.  
**Thos. F. G. & Sons**, Buffalo, N. Y.

**Howard, Childs & Co.**, Hamilton Building, Pittsburgh.  
**Laclede Car Co.**, 4500 N. Second st., St. Louis, Mo.  
**LEWIS & FOWLER MFG. CO.** (The), 27 to 35 Walworth st., Brooklyn, N. Y.

**MARTIN, RUFUS, & CO.**, 13 Park Row, New York (ride Bearings).  
**PUGH & RUSSELL**, Stewart Bldg., New York; Phoenix Bldg., Chicago, Ill.

**St. Thomas Car Wheel Co.**, St. Thomas, Ont., Canada.  
**Wm. P. Craig**, 258 Market st., San Francisco, Cal.  
**STREET RAILWAY SUPPLY CO.**, Cleveland, Ohio.  
**Universalized Fire Co.**, Wilmington, Del. (New York office, 14 DeWitt st.)

**Wm. Wharton, Jr. & Co.** (Incorporated), 25th st. and Washington ave., Philadelphia, Pa.  
**Wharton, Childs & Co.**, Hamilton Bldg., Pittsburgh.  
**WHITNEY, A., & SONS**, Philadelphia, Pa.

**BROOMS (Bass and Rattan).**  
**BROOKLYN RAILWAY SUPPLY CO.** (The), 44 Water-st., Brooklyn, N. Y.

**BRUSHES (Horse).**  
**Phoenix Steel Wire Broom & Brush Co.**, 199 E. Randolph st., Chicago, Ill.

**BRUSHES (Paint).**  
**COFFIN, DEVOE & CO.**, 176 Randolph st., Chicago, Ill.

**CABLE CONDUITS.**  
**WAY FOUNDRY CO.** (The), 23rd and Wood sts., Philadelphia, Pa.

**CABLE RAILWAY PATENTS.**  
**Noble Railway Co.** (The), 329 Market st., San Francisco.  
**National Cable Railway Co.** (The), 140 Nassau st. (room 29), New York. (Agents—All the original and fundamental United States patents (embracing the Hallidie system) covering the construction and operation of Cable Railways for all that portion of the United States lying east of the 106th degree of longitude.)

**Patent Cable Tramways Corporation** (The), Limited, 2 Victoria Buildings, 59 St. Paul London, Eng.  
**Wm. Wharton, Jr. & Co.** (Incorporated), 25th st. and Washington ave., Philadelphia, Pa.

**CABLE RAILWAY PLANTS.**  
**Hooven, Owens & Reuschler Co.** (The), Hamilton, Ohio.  
**FOOLE & HUNT**, Baltimore, Md. (ride Grapes).

**CABLE RY. SWITCHES (Automatic).**  
**Wm. Wharton, Jr. & Co.** (Incorporated), 25th st. and Washington ave., Philadelphia, Pa.

**CABLE RAILWAY WORK.**  
**WAY FOUNDRY CO.** (The), 23rd and Wood sts., Philadelphia, Pa.

**CABLES.**  
**BROOKS & BASCOM ROPE CO.**, 704 N. Main st., St. Louis.  
**Bullivant & Co.**, 72 Mark Lane, London, E. C.  
**Cable Railway Co.**, 329 Market st., San Francisco, Cal.  
**Greely** (The) E. S. & Co., 5 and 7 Day st., New York.  
**HAZARD MFG. CO.**, Wilkes Barre, Pa. (Branches—100 Broadway, New York; 159 River st., Philadelphia, O. 91 Commercial st., Boston, Mass.; 25 Sante Gay st., Baltimore, Md.; 358 S. Main st., Salt Lake City, Utah; 38 S. 3rd st., Chicago, Ill.; 3 Sixth ave., Pittsburgh, Pa.; 21 Fremont st., San Francisco, Cal.; 703 Main st., Philadelphia, Pa.; 35 S. Delaware ave., Philadelphia, Pa.; 100 Broadway, New York; 100 Broadway, New York; 100 Broadway, New York.)  
**JOHNSON TOM B.**, Indianapolis, Ind.  
**Post & Company**, Cincinnati, Ohio.  
**Rosenblum's Cable Co.**, room 606 First National Bank Building, Chicago, Ill.

**ROUSSELL'S SONS CO.**, JOHN A., 117 and 119 Liberty st., New York.  
**WASHBURN & MOEN MANUFACTURING CO.**, Worcester, Mass. (Warehouses—16 Cliff st., New York; 107 and 109 Lake st., Chicago.)

**CABLE SHEAVES.**  
**WAY FOUNDRY CO.** (The), 23d and Wood sts., Philadelphia, Pa.

**CABLE YOKES.**  
**BALTIMORE CAR WHEEL CO.** (The), Baltimore, Md. (ride Axles).  
**Greely** (The) E. S. & Co., 5 and 7 Day st., New York.  
**HORACE A. KEFFER, Co.** (The), Kansas City, Mo.  
**JOHNSON STEEL STREET RAIL CO.** (The), Johnsonstown, Pa. (Branches—Chicago, Chicago; Exchange Building, New Orleans; Phoenix Building, Chicago; Bank of Commerce Building, St. Louis, Mo.; 6 Oliver st., Boston; Stewart Building, New York; Johnson Building, Cincinnati; 252 W. Main st., Louisville, Ky.)

**Med. St. Street Railway Supply Co.**, 37 State st., Albany, N. Y. (Agent—FRANK H. ANDREWS, 545 W. 33rd st., New York.)

**CAR BUILDERS.**  
**Brih (G. G.) Co.**, Philadelphia.  
**HOWARD, CHILDS & CO.**, Hamilton Bldg., Pittsburgh. (Works—Victoria Bldg., West Chester, Pa.)  
**Dick, Kerr & Co.**, 101 Leadenhall st., E. C., London.  
**Works—Hartlands Engineering Works, Kilmarnock N. B.**

**Falcon Engine & Car Works, Limited**, Loughborough, Eng. (London office—11 Coleman st., E. C.)  
**Peigel Car Co.** (The), 108 Wall st., New York.  
**James J. M. Soria**, West Troy, N. Y.

**KUHLMANN & CO.**, 400 St. Clair st., Cleveland, O.  
**Laclede Car Co.**, 4500 N. Second st., St. Louis, Mo.  
**Lancaster Wagon Co.** (The), Limited, Lancaster. (London office—1 Victoria Bldg., Westminster, N. W.)

**MARTIN, RUFUS, & CO.**, 13 Park Row, New York (ride Bearings).  
**Metropolitan Carriage and Wagon Works**, Birmingham, England.

**PUGH & RUSSELL**, Stewart Bldg., New York; Phoenix Bldg., Chicago, Ill.  
**PULLMAN'S PALACE CAR CO.**, Chicago; Pullman, Ill.; Detroit, Mich.

**Robinson & Hill**, Waterloo, Iowa.  
**St. Louis Car Co.** (The), 3023 Broadway, St. Louis, Mo.  
**Starbuck Car and Wagon Co.** (The), Limited, Barkenhead. (London office—64, Winchester st., Building, E. C.)

**STEPHENSON (JOHN) COMPANY**, Lima, New York. Wm. Wharton, Jr. & Co. (Incorporated), 25th st. and Washington ave., Philadelphia, Pa.

**CAR (Electric) BUILDERS.**  
**Glasgow Carriage and Electric Tramway** (W. A. Traill, Engineer), Co. Antrim, Ireland.

**CAR CASTINGS.**  
**ADAMS & WESTLAKE CO.** (The), 110 Ontario st., Chicago, Ill. (Branch—115 Broadway, New York.)  
**ANDREWS, FRANK H.**, 545 W. 33rd st., New York (ride Brakes).

**Askew, Bros. & Wilson**, Limited, Sheffield, England.  
**Avery**, Abraham, 502 to 518 W. 45th st., New York.  
**BALTIMORE CAR WHEEL CO.** (The), Baltimore, Md. (ride Axles).

**BROWNELL & WIGHT CAR CO.**, 2300 Broadway, St. Louis, Mo.  
**Chester Steel Castings Co.**, 407 Library st., Philadelphia.  
**Craig Wm. P.**, 95 Liberty st., New York.

**FULTON FOUNDRY**, Cleveland, O. (ride Axles).  
**Howard, Childs & Co.**, Hamilton Bldg., Pittsburgh.  
**Kaestner, Chas. & Co.**, 303 S. Canal st., Chicago, Ill.  
**Keystone Smelting Co.** (The), Limited, 33rd st., Pittsburgh, Pa.

**Laclede Car Co.**, 4500 N. Second st., St. Louis, Mo.  
**LEWIS & FOWLER MFG. CO.** (The), 27 to 35 Walworth st., Brooklyn, N. Y.

**MARTIN, RUFUS, & CO.**, 13 Park Row, New York (ride Bearings).  
**Post & Company**, Cincinnati, Ohio.  
**PUGH & RUSSELL**, Stewart Bldg., New York; Phoenix Bldg., Chicago, Ill.

**St. Thomas Car Wheel Co.**, St. Thomas, Ont., Canada.  
**SNED & BIBB**, Louisville, Ky.  
**STREET RAILWAY SUPPLY CO.**, Cleveland, Ohio.  
**Wm. Wharton, Jr. & Co.** (Incorporated), 25th st. and Washington ave., Philadelphia, Pa.  
**Whiting Mfg. Co.**, Cedar Rapids, Ia.  
**WHITNEY, A., & SONS**, Philadelphia, Pa.

**CAR CELLINGS.**  
**ADAMS & WESTLAKE CO.** (The), 110 Ontario st., Chicago, Ill. (Branch—115 Broadway, New York.)  
**Brih (G. G.) Co.**, Philadelphia.  
**BROWNELL & WIGHT CAR CO.**, 2300 Broadway, St. Louis, Mo.

**Daxton Mfg. Co.** (The), Dayton, Ohio.  
**GAIRDNER & CO.**, 47 W. 42nd st., New York. (Factory—643 to 657 W. 48th st., New York.)  
**Greely** (The) E. S. & Co., 5 and 7 Day st., New York.  
**KUHLMANN CAR CO.**, 400 St. Clair st., Cleveland, O.  
**Laclede Car Co.**, 4500 N. Second st., St. Louis, Mo.

**MARTIN, RUFUS, & CO.**, 13 Park Row, New York (ride Bearings).  
**PUGH & RUSSELL**, Stewart Bldg., New York; Phoenix Bldg., Chicago, Ill.  
**Purdy & Huntington Co.**, Lima, 60 Shoe Lane, London, New York.

**CAR HEATER FITTINGS (Hose, &c.)**  
**Gold, Edw. E.**, & Co., ce. cor. Frankfort and Cliff sts., New York.  
**Greely** (The) E. S. & Co., 5 and 7 Day st., New York.

**CAR HEATERS.**  
**ADAMS & WESTLAKE CO.** (The), 110 Ontario st., Chicago, Ill. (Branch—115 Broadway, New York.)  
**Brih (G. G.) Co.**, Philadelphia.  
**CINE MFG. CO.**, 27 and 278 S. Canal st., Chicago.  
**Hunt, Geo. H.**, West Troy, N. Y.  
**Wm. Wharton, Jr. & Co.**, cor. Frankfort and Cliff sts., New York.

**Greely** (The) E. S. & Co., 5 and 7 Day st., New York.  
**Laclede Car Co.**, 4500 N. Second st., St. Louis, Mo.  
**LEWIS & FOWLER MFG. CO.** (The), 27 to 35 Walworth st., Brooklyn, N. Y.

**MARTIN, RUFUS, & CO.**, 13 Park Row, New York (ride Bearings).  
**Metropolitan Carriage and Wagon Co.**, 219 and 221 Market st., St. Louis, Mo.

**Post & Company**, Cincinnati, Ohio.  
**PUGH & RUSSELL**, Stewart Bldg., New York; Phoenix Bldg., Chicago, Ill.

**STREET RAILWAY SUPPLY CO.**, Cleveland, Ohio.

**CAR LAMPS.**  
**ADAMS & WESTLAKE CO.** (The), 110 Ontario st., Chicago, 115 Broadway, New York.  
**Brih (G. G.) Co.**, Philadelphia.  
**BROWNELL & WIGHT CAR CO.**, 23 Broadway, St. Louis, Mo.

**Crute, Geo. H.**, West Troy, N. Y.  
**Dayton Mfg. Co.** (The), Dayton, Ohio.  
**Greely** (The) E. S. & Co., 5 and 7 Day st., New York.  
**Laclede Car Co.**, 4500 N. Second st., St. Louis, Mo.  
**LEWIS & FOWLER MFG. CO.** (The), 27 to 35 Walworth st., Brooklyn, N. Y.

**MARTIN, RUFUS & CO.**, 13 Park Row, New York (ride Bearings).  
**Miller Chas. B.**, 310 E. 14th st., New York.  
**Post & Company**, Cincinnati, Ohio.  
**PUGH & RUSSELL**, Stewart Bldg., New York; Phoenix Bldg., Chicago, Ill.

**SMITH, JOSEPHINE D.**, 350 Pearl st., New York.

**CAR MORTISERS.**  
**LANE & BODLEY CO.** (The), 267 to 283 Water st., Cincinnati, Ohio.



**CARS (Sand and Salt).**  
**BROOKLYN RAILWAY SUPPLY CO.** (The), 44 Walworth st., Brooklyn, N. Y.

**CAR SASH.**  
Ayers Patent Holder Co., 242 Stewart Bldg., New York  
Brill (J. G.) Co., Philadelphia.  
**BROWNELL & WIGHT CAR CO.**, 2300 Broadway, St. Louis, Mo.  
Dayton Mfg. Co. (The), Dayton, Ohio.  
Greely, The E. S., & Co., 5 and 7 Day st., New York.  
**KUHLMANN CAR CO.**, 490 St. Clair st., Cleveland, O.  
Laclede Car Co., 4500 N. Second st., St. Louis, Mo.  
**MARTIN, RUFUS, & CO.**, 13 Park Row, New York (vide Bearings).  
**PUGH & RUSSELL**, Stewart Bldg., New York; Phoenix Bldg., Chicago, Ill.

**CAR SEATS.**  
**ADAMS & WESTLAKE CO.** (The), 110 Ontario st., Chicago, 15 Broadway, New York.  
Brill (J. G.) Co., Philadelphia.  
**BROWNELL & WIGHT CAR CO.**, 2300 Broadway, St. Louis, Mo.  
Dayton Mfg. Co. (The), Dayton, Ohio.  
Frost & Peterson, 161 W. 15th st., New York.  
Gardner & Co., 642 to 657 W. 49th st., New York.  
Greely, The E. S., & Co., 5 and 7 Day st., New York.  
Hale & Kilburn Mfg. Co. (The), 48 and 50 N. 6th st., Philadelphia.

**HARTFORD WOVEN WIRE MATTRESS CO.** (The), postoffice box 363, Hartford, Conn.  
**KUHLMANN CAR CO.**, 490 St. Clair st., Cleveland, O.  
Laclede Car Co., 4500 N. Second st., St. Louis, Mo.  
**MARTIN, RUFUS, & CO.**, 13 Park Row, New York (vide Bearings).  
Post & Company, Cincinnati, Ohio.  
**PUGH & RUSSELL**, Stewart Bldg., New York; Phoenix Bldg., Chicago, Ill.  
Purdy & Huntington Co., Limited, 60 Shoe Lane, E. C., London.  
Walefield Battaon Co., Boston, Mass. (Branches—644 Market st., San Francisco; 144 and 146 Washab av., Chicago; 924 Broadway, and 8 Park pl., New York.)

**CARS (Second Hand).**  
Brill (J. G.) Co., Philadelphia.  
**BROOKLYN RAILWAY SUPPLY CO.** (The), 44 Walworth st., Brooklyn, N. Y.  
**BROWNELL & WIGHT CAR CO.**, 2300 Broadway, St. Louis, Mo.  
Greely, The E. S., & Co., 5 and 7 Day st., New York.  
Humphreys & Co., 1 Broadway, New York.  
**MARTIN, RUFUS, & CO.**, 13 Park Row, New York (vide Bearings).  
**PUGH & RUSSELL**, Stewart Bldg., New York; Phoenix Bldg., Chicago, Ill.

**CAR SHEDS AND STABLES.**  
Evans, H. D., Sunnyside Works, Horsey Rise, N. London.

**CAR SIGNALS.**  
Brill (J. G.) Co., Philadelphia.

**CAR SIGNS.**  
Brill (J. G.) Co., Philadelphia.

**CAR SPRINGS.**  
**ANDREWS, FRANK H.**, 545 W. 33rd st., New York (vide Brakes).  
**BALTIMORE CAR WHEEL CO.** (The), Baltimore, Md. (vide Axles).  
**BEMIS CAR BOX CO.**, Springfield, Mass.  
Brill (J. G.) Co., Philadelphia.  
**BROWNELL & WIGHT CAR CO.**, 2300 Broadway, St. Louis, Mo.  
Diamond State Car Spring Co., 8th and Railroad av., Wilmington, Del.  
Greely, The E. S., & Co., 5 and 7 Day st., New York.  
Howard, Childs & Co., Hamilton Bldg., Pittsburgh, Pa.  
**LEWIS & FOWLER MFG. CO.** (The), 27 to 35 Walworth st., Brooklyn, N. Y.  
**MARTIN, RUFUS, & CO.**, 13 Park Row, New York (vide Bearings).  
Pickering Spring Co., Limited, Philadelphia, Pa.  
Post & Company, Cincinnati, Ohio.  
**PUGH & RUSSELL**, Stewart Bldg., New York; Phoenix Bldg., Chicago, Ill.  
**STREET RAILWAY SUPPLY CO.**, Cleveland, Ohio.  
**VOSE, RICHARD L.**, 130 West 14th St., (Branches—104 N. 3rd st., St. Louis; 117 Adams Express Bldg., Chicago, Ill.)

**CAR STARTERS.**  
**BAKER, W. S. GRAFF**, care Brown, Shipley & Co., London (vide Car Starters).  
**BALTIMORE CAR WHEEL CO.** (The), Baltimore, Md. (vide Axles).  
Broadwell, C. B., 169 Laurel st., New Orleans, La.  
Chester Steel Castings Co., 407 Library st., Philadelphia.  
Greely, The E. S., & Co., 5 and 7 Day st., New York.  
**MARTIN, RUFUS, & CO.**, 13 Park Row, New York (vide Bearings).  
Post & Company, Cincinnati, Ohio.  
Wiser & Vail, 272 Pearl st., Cleveland, Ohio.

**CAR TRIMMINGS.**  
**ADAMS & WESTLAKE CO.** (The), 110 Ontario st., Chicago, 15 Broadway, New York.  
Brill (J. G.) Co., Philadelphia.  
**BROWNELL & WIGHT CAR CO.**, 2300 Broadway, St. Louis, Mo.  
Dayton Mfg. Co. (The), Dayton, Ohio.  
Greely, The E. S., & Co., 5 and 7 Day st., New York.  
Laclede Car Co., 4500 N. Second st., St. Louis, Mo.  
**LEWIS & FOWLER MFG. CO.** (The), 27 to 35 Walworth st., Brooklyn, N. Y.  
**MARTIN, RUFUS, & CO.**, 13 Park Row, New York (vide Bearings).  
Miller, Chas. F., 310 E. 14th st., New York.  
Post & Company, Cincinnati, Ohio.  
**PUGH & RUSSELL**, Stewart Bldg., New York; Phoenix Bldg., Chicago, Ill.  
**SMITH, JOSEPHINE D.**, 350 Pearl st., New York.  
Stewart & Matson Mfg. Co. (The), 2042 N. 10th st., Philadelphia.  
White Edw. C., 531 W. 33rd st., New York.

**CAR WHEELS.**  
**ANDREWS, FRANK H.**, 545 W. 33rd st., New York (vide Brakes).  
**BAKER, W. S. GRAFF**, care Brown, Shipley & Co., London (vide Car Starters).  
**BALTIMORE CAR WHEEL CO.** (The), Baltimore, Md. U. S. A. (Agents—O. W. Meyenberg & Co., Chicago and St. Louis; W. S. Graff, care of Brown, Shipley & Co., London; W. S. Graff, care of England).  
**BEMIS CAR BOX CO.**, Springfield, Mass.  
Bowler & Co., Cleveland, Ohio.  
Brill (J. G.) Co., Philadelphia.  
**BROWNELL & WIGHT CAR CO.**, 2300 Broadway, St. Louis, Mo.  
Chester Steel Castings Co., 407 Library st., Philadelphia.

**FULTON FOUNDRY**, Cleveland, O. (vide Axles).  
Griffin, Thos. F., & Sons, Buffalo, N. Y.  
Griffin Wheel and Foundry Co., Robey st. and Blue Island av., Chicago, Ill.  
Hadfield's Steel Foundry Co., Attercliffe, Sheffield, Eng.  
**HORACE A. KEEFER CO.** (The), Kansas City, Mo.  
Howard, Childs & Co., Hamilton Bldg., Pittsburgh, Pa.  
Laclede Car Co., 4500 N. Second st., St. Louis, Mo.  
**LEWIS & FOWLER MFG. CO.** (The), 27 to 35 Walworth st., Brooklyn, N. Y.

**MARTIN, RUFUS, & CO.**, 13 Park Row, New York (vide Bearings).  
Miller & Co., London Road Foundry, Edinburgh, Scot.  
Peckham Car Wheel Co. (The), Syracuse, N. Y.  
**PUGH & RUSSELL**, Stewart Bldg., New York; Phoenix Bldg., Chicago, Ill.  
**STREET RAILWAY SUPPLY CO.**, Cleveland, Ohio.  
St. Thomas Car Wheel Co., St. Thomas, Ont., Canada.  
**WHITNEY, A. & SONS**, Philadelphia, Pa.

**CEMENTS (For Cable Roads).**  
Empire Warehouse Co., 210 Market st., Chicago, Ill.

**CHAIRS.**  
**JOHNSON STEEL STREET RAIL CO.** (The), Johnstown, Pa. (vide Cable Yokes).  
Wilson, Pease & Co., Middleborough-on-Tees, England.

**CHANGE RECEIPTS.**  
**MASSON, MILTON I.** (Agent for Slawson's Patents), 365 Avenue A, New York.  
**W. W. MANFIELD & CO.**, 76 and 78 E. Water st., Syracuse, N. Y.  
Whiting, T. J., 74 South Place, Finsbury, London.

**CHANNET TABLES.**  
**ANDREWS, FRANK H.**, 545 W. 33rd st., New York (vide Brakes).  
Ayers, Abraham, 580 to 518 1/2, 45th st., New York.  
Crang, Wm. F., 95 Liberty st., New York.  
**HORACE A. KEEFER CO.** (The), Kansas City, Mo.  
Howard, Childs & Co., Hamilton Bldg., Pittsburgh, Pa.  
**JOHNSON STEEL STREET RAIL CO.** (The), Johnstown, Pa. (vide Cable Yokes).  
**LEWIS & FOWLER MFG. CO.** (The), 27 to 35 Walworth st., Brooklyn, N. Y.  
**MARTIN, RUFUS, & CO.**, 13 Park Row, New York (vide Bearings).  
**PUGH & RUSSELL**, Stewart Bldg., New York; Phoenix Bldg., Chicago, Ill.  
Wm. Wharton, Jr., & Co. (Incorporated), 25th st. and Washington av., Philadelphia, Pa.

**CHIMNEYS, BURNERS & WICKS.**  
**ADAMS & WESTLAKE CO.** (The), 110 Ontario st., Chicago, 15 Broadway, New York.  
Clute, Geo. M., West Troy, N. Y.

**CLUTCH AXLES.**  
**BALTIMORE CAR WHEEL CO.** (The), Baltimore, Md. (vide Car Wheels).

**COLOIS.**  
**COPIN, DEVON & CO.**, 176 Randolph st., Chicago, Ill.  
Sherwin & Wilson Co., 100 Canal st., Cleveland, O. (Branches—241 Jackson st., Chicago, Ill.; 178 Fulton st., New York.)

**CONCRETE MIXERS.**  
**CALDWELL, H. H.**, 130 West Washington st., Chicago.  
Kaestner Chas. & Co., 303 S. Canal st., Chicago, Ill.

**CONNECTING TRACKS.**  
**JOHNSON STEEL STREET RAIL CO.** (The), Johnstown, Pa. (vide Cable Yokes).

**CONTRACTORS AND BUILDERS.**  
**ANDREWS, FRANK H.**, 545 W. 33rd st., New York (vide Brakes).  
**BAKER, W. S. GRAFF**, care Brown, Shipley & Co., London (vide Car Starters).  
Cleveland Electric Motor Co. (Geo. W. Mansfield, Spt. and electrician), 1st National Bank Building, Cleveland, Ohio.  
Conway, M. W., 487 Moore st., Brooklyn, N. Y.  
Crang Wm. F., 95 Liberty st., New York.  
Haines Bros., 55 Broadway, New York.  
Harris F. Wm. & Co., 2 Nassau st. (room 17), New York.  
**HATHAWAY & ROBINSON**, 14 Case Bldg., Cleveland, O.  
**HORACE A. KEEFER CO.** (The), Kansas City, Mo.  
Hutchinson, A. J., 120 Broadway, New York.  
**LEWIS & FOWLER MFG. CO.** (The), 27 to 35 Walworth st., Brooklyn, N. Y.  
Nettel & Oothout, 41 Liberty st., New York.  
New York Railway Supply Co., 42 Wall st., New York.  
Raymond & James, 100 Broadway, New York.  
Wilkes & Co., 7 Bishop's Gate, E. C., London.  
Wm. Wharton, Jr., & Co. (Incorporated), 25th st. and Washington av., Philadelphia, Pa.

**CONSTRUCTION CARS.**  
**BROOKLYN RAILWAY SUPPLY CO.** (The), 44 Walworth st., Brooklyn, N. Y.

**CROSSINGS.**  
**ANDREWS, FRANK H.**, 545 W. 33rd st., New York (vide Brakes).  
**BALTIMORE CAR WHEEL CO.** (The), Baltimore, Md. (vide Car Wheels).  
Chester Steel Castings Co., 407 Library st., Philadelphia.  
Crang Wm. F., 95 Liberty st., New York.  
**FULTON FOUNDRY**, Cleveland, O. (vide Axles).  
Greely, The E. S., & Co., 5 and 7 Day st., New York.  
**HORACE A. KEEFER CO.** (The), Kansas City, Mo.  
Howard, Childs & Co., Hamilton Bldg., Pittsburgh, Pa.  
**JOHNSON STEEL STREET RAIL CO.** (The), Johnstown, Pa. (vide Cable Yokes).  
**LEWIS & FOWLER MFG. CO.** (The), 27 to 35 Walworth st., Brooklyn, N. Y.  
Pennsylvania Car Co., Philadelphia, (vide Axles).  
**PUGH & RUSSELL**, Stewart Bldg., New York; Phoenix Bldg., Chicago, Ill.  
**SNEAD & BIRD**, Louisville, Ky.  
**WAY FOUNDRY CO.** (The), 23d and Wood sts., Philadelphia, Pa.

**WHITNEY, A. & SONS**, Philadelphia, Pa.  
Wm. Wharton, Jr., & Co. (Incorporated), 25th st. and Washington av., Philadelphia, Pa.

**CROSSINGS (Cable and Electric Ry.)**  
Wm. Wharton, Jr., & Co. (Incorporated), 25th st. and Washington av., Philadelphia, Pa.

**CURVES.**  
**WAY FOUNDRY CO.** (The), 23d and Wood sts., Philadelphia, Pa.

**DOOR STOPS.**  
**ADAMS & WESTLAKE CO.** (The), 110 Ontario st., Chicago, 15 Broadway, New York.  
Brill (J. G.) Co., Philadelphia, Pa.  
**BROWNELL & WIGHT CAR CO.**, 2300 Broadway, St. Louis, Mo.  
Greely, The E. S., & Co., 5 and 7 Day st., New York.  
Haycox Door Fastener Co., 1158 Euclid av., Cleveland, Ohio.

**MARTIN, RUFUS, & CO.**, 13 Park Row, New York (vide Bearings).  
Miller Chas. F., 310 E. 14th st., New York.  
Post & Company, Cincinnati, Ohio.  
**PUGH & RUSSELL**, Stewart Bldg., New York; Phoenix Bldg., Chicago, Ill.

**DRAW HEADS.**  
Brill (J. G.) Co., Philadelphia, Pa.

**DRIVING MACHINERY.**  
**HORACE A. KEEFER CO.** (The), Kansas City, Mo.  
**HANE & BODLEY CO.** (The), 283 Water st., Cincinnati, Ohio.  
**POOLE & HUNT**, Baltimore, Md. (vide Grips).

**DUST GUARDS (For Oil Boxes).**  
**VULCANIZING FIBRE CO.**, Wilmington, Delaware. (New York office, 407 W. 11th St.)

**ELECTRIC RAILWAY CASTINGS.**  
Wm. Wharton, Jr., & Co. (Incorporated), 25th st. and Washington av., Philadelphia, Pa.

**ELECTRIC RAILWAY PATENTS.**  
**OVERHEAD CONDUCTOR ELECTRIC RAILWAY** (The), (Thomas B. Kerr, Sec'y.), Pittsburgh, Pa.

**ELECTRIC RAILWAYS (Equipment).**  
**BENTLEY-KNIGHT ELECTRIC RAILWAY CO.**, 115 Broadway, New York, Constructors (Rhode Island Locomotive Works).  
**DAFT ELECTRIC LIGHT CO.** (The), 115 Broadway, New York.  
**SAFETY ELECTRIC CONSTRUCTION CO.** (Daft System), 41 Wall st., New York. (Factory at Greenview, N. Y.)  
**SPRAGUE ELECTRIC RAILWAY & MOTOR CO.**, 16 and 18 Broad st., New York. (Special work at New York factory, 53 Jettison av., Detroit; 185 Dearborn st., Chicago; 304 Locust st., St. Louis; 119 S. 34th st., Philadelphia; 117 Public sq., Cleveland, O.)  
**VAN DERBEEK ELECTRIC MFG. CO.**, 15, 17, 19 and 21 N. Clinton st., Chicago. (Branch—45 Broadway, New York.)

**ELEVATED RAILWAYS.**  
Meigs & Co., 225 Bridge st., East Cambridge, Boston, Mass.  
Riley Railway Construction Co. (The), Bloomfield, N. J. (Branches—15 Greenview st., New York.)

**ENGINEERS' INSTRUMENTS (Survey).**  
**ALOE, A. & CO.**, 300 N. Fourth st., St. Louis, Mo.  
**PARE BOXES.**  
**ADAMS & WESTLAKE CO.** (The), 110 Ontario st., Chicago, 15 Broadway, New York.  
Beaman, T. L., Knoxville, Tenn.  
**BROWNELL & WIGHT CAR CO.**, 2300 Broadway, St. Louis, Mo.  
Greely, The E. S., & Co., 5 and 7 Day st., New York.  
**HORACE A. KEEFER CO.** (The), Kansas City, Mo.  
**JOHNSON, TOM L.**, Indianapolis, Ind.  
Laclede Car Co., 4500 N. Second st., St. Louis, Mo.  
**LEWIS & FOWLER MFG. CO.** (The), 27 to 35 Walworth st., Brooklyn, N. Y.

**MARTIN, RUFUS, & CO.**, 13 Park Row, New York (vide Bearings).  
**MASSON, MILTON I.** (agent for Slawson's boxes), 365 Avenue A, New York.  
**PUGH & RUSSELL**, Stewart Bldg., New York; Phoenix Bldg., Chicago, Ill.  
**STEPHENSON (JOHN) COMPANY**, Lim., New York.  
**WALLES MFG. CO.**, 76 and 78 E. Water st., Syracuse, New York.  
Whiting, T. J., 74 South Place, Finsbury, London.

**FARE COLLECTORS (Automatic).**  
Greely, The E. S., & Co., 5 and 7 Day st., New York.  
Joseph, John, London office—93 High Holborn, W. C., London.  
Laclede Car Co., 4500 N. Second st., St. Louis, Mo.  
**LEWIS & FOWLER MFG. CO.** (The), 27 to 35 Walworth st., Brooklyn, N. Y.  
**MARTIN, RUFUS, & CO.**, 13 Park Row, New York (vide Bearings).

**FARE REGISTERS.**  
Bell Punch Co. (The), Limited, 24 Tabernacle st., Finsbury, London.  
Brill (J. G.) Co., Philadelphia.  
Greely, The E. S., & Co., 5 and 7 Day st., New York.  
Joseph, John, London office—93 High Holborn, W. C., London.  
Laclede Car Co., 4500 N. Second st., St. Louis, Mo.  
**LEWIS & FOWLER MFG. CO.** (The), 27 to 35 Walworth st., Brooklyn, N. Y.

**FASTENINGS.**  
Cambria Iron Co., 218 S. 4th st., Philadelphia. (vide Axles).  
**KREIDER CUTTERS.**  
Belle City Mfg. Co., 2nd St., Wis.  
Kestner, Charles & Co., 303 S. Canal, Chicago.  
**MARTIN, RUFUS, & CO.**, 13 Park Row, New York (vide Bearings).  
**PUGH & RUSSELL**, Stewart Bldg., New York; Phoenix Bldg., Chicago, Ill.

**FEDD MILLS.**  
The Foss Mill Co., Springfield, O.  
Kestner, Chas. & Co., 303 S. Canal st., Chicago.  
**MARTIN, RUFUS, & CO.**, 13 Park Row, New York (vide Bearings).  
Noye, The J. T. Mfg. Co., Buffalo, N. Y. (Branches at Chicago, Ill. and Minneapolis, Minn.)  
**PUGH & RUSSELL**, Stewart Bldg., New York; Phoenix Bldg., Chicago, Ill.

**FLOOR PAINT.**  
**CHICAGO WOOD FINISHING CO.**, 143 and 145 S. Clinton st., Chicago, Ill.

**FOLDING MATS.**  
Factory—1193 Broadway, New York (Factory—Crawford N. Y.) "Eureka" Mat.  
Warneck & Toiller, 211 E. 23d st., New York. "Rolling Wood Mat."



**FROGS.**  
**ANDREWS, FRANK H.**, 545 W. 33rd st., New York (vide Brake).  
 Ayres, Abraham, 502 to 518 W. 45th st., New York.  
**BALTIMORE CAR WHEEL CO. (The)**, Baltimore.  
 Chester Steel Castings Co., 407 Library st., Philadelphia.  
 Craig, Wm. P., 95 Liberty st., New York.  
**FULTON FOUNDRY**, Cleveland, O. (vide Axles).  
 Greeley, The E. S., & Co., 5 and 7 Dey st., New York.  
**HORACE A. KEEFER CO. (The)**, Kansas City, Mo.  
 Howard, Childs & Co., Hamilton Bldg., Pittsburgh, Pa.  
**JOHNSTON STEEL STREET RAIL CO. (The)**, Johnstown, Pa. (vide Cable Yokes).  
 Johnson Railroad Frog Switch Co., 307 Walnut st., Philadelphia.  
**LEWIS & FOWLER MFG. CO. (The)**, 27 to 35 Walworth st., Brooklyn, N. Y.  
**MARTIN, RUFUS, & CO.**, 13 Park Row, New York (vide Bearings).  
 Metcalf Street Railway Supply Co., Albany, N. Y. (vide Cable Yokes).  
 Pennsylvania Steel Co., Philadelphia (vide Axles).  
**PUGH & RUSSELL, Stewart Bldg.**, New York; Phoenix Bldg., Chicago, Ill.  
**WAY FOUNDRY CO. (The)**, 23rd and Wood sts., Philadelphia, Pa.  
 Wm. Wharton, Jr., & Co. (Incorporated), 25th st. and Washington ave., Philadelphia, Pa.  
 Whiting Manufacturing Co., Cedar Rapids, Iowa.

**GLASS.**  
 Mississippi Glass Co., Main and Angelotta sts., St. Louis, Mo. (Agent—Gilbert S. King, 102 Chambers st., New York).  
 The Western Nard Blast Co., nw. cor. Clinton and Jackson sts., Chicago, Ill.

**GREASE.**  
 Chicago Lubricant Mfg. Co., 51 Dearborn st., Chicago.  
 Leis Lubricating Co., Buffalo, N. Y. (Agents—Frazitt & Gault, 108 Barre, Pa.).

**GRINDERS (Car Wheel).**  
 Greeley, The E. S., & Co., 5 and 7 Dey st., New York.  
 Post & Company, Cincinnati, Ohio.  
**PUGH & RUSSELL, Stewart Bldg.**, New York; Phoenix Bldg., Chicago, Ill.

**GRIPS (Cable).**  
**ANDERS, D. H.**, 3213 Ridge ave., Philadelphia, Pa.  
**BALTIMORE CAR WHEEL CO. (The)**, Baltimore, Md. (vide Car Wheels).  
 Chester Steel Castings Co., 407 Library st., Philadelphia.  
 Craig, Wm. P., 95 Liberty st., New York.  
**FULTON FOUNDRY**, Cleveland, O. (vide Axles).  
**JOHNSTON STEEL STREET RAIL CO. (The)**, Johnstown, Pa. (vide Cable Yokes).  
**LANE & BODLEY CO. (The)**, 267-283 Water st., Cincinnati, Ohio.  
**POOLE & HUNT**, Baltimore, Md. (Works at Woodberry, Maryland).  
 Wm. Wharton, Jr., & Co. (Incorporated), 25th st. and Washington ave., Philadelphia, Pa.

**GROOMING MACHINES.**  
**PUGH & RUSSELL, Stewart Bldg.**, New York; Phoenix Bldg., Chicago, Ill.

**GROOVED CURVES.**  
**ANDREWS, FRANK H.**, 545 W. 33rd st., New York (vide Brake).  
 Craig, Wm. P., 95 Liberty st., New York.  
**FULTON FOUNDRY**, Cleveland, Ohio (vide Axles).  
 Howard, Childs & Co., Hamilton Bldg., Pittsburgh, Pa.  
**JOHNSTON STEEL STREET RAIL CO. (The)**, Johnstown, Pa. (vide Cable Yokes).  
**LEWIS & FOWLER MFG. CO. (The)**, 27 to 35 Walworth st., Brooklyn, N. Y.  
 Pennsylvania Steel Co., Philadelphia (vide Axles).  
**PUGH & RUSSELL, Stewart Bldg.**, New York; Phoenix Bldg., Chicago, Ill.  
**SNEAD & BIBB**, Louisville, Ky.  
 Wm. Wharton, Jr., & Co. (Incorporated), 25th st. and Washington ave., Philadelphia, Pa.

**HAMES COUPLERS.**  
**DICKSON, C. H.**, Seely Northern Central Ry. Co., St. Louis, Mo.

**HARNES.**  
 Brill (J. G.) Co., Philadelphia.  
 Leckie (John) & Co., London (12 St. Mary Axe, E. C.).  
 Rossow and Wakell Eng.  
**MARTIN, RUFUS, & CO.**, 13 Park Row, New York (vide Bearings).  
**PUGH & RUSSELL, Stewart Bldg.**, New York; Phoenix Bldg., Chicago, Ill.

**HEAD-LIGHTS & LANTERNS.**  
**ADAMS & WESTLAKE CO. (The)**, 110 Ontario st., Chicago, Ill.; 115 Broadway, New York.

**HORSE-SHOE NAILS.**  
 Champion Horse Nail Co., Appleton, Wis.  
 Howard, Childs & Co., Hamilton Bldg., Pittsburgh, Pa.  
 Kimbark, S. D., Michigan ave. and Lake st., Chicago, Ill.  
 Northwestern Nail Co., 232 S. Clinton st., Chicago.  
**PUGH & RUSSELL, Stewart Bldg.**, New York; Phoenix Bldg., Chicago, Ill.  
 Putnam Nail Co. (Co.), Neponset P. O., Boston, Mass.  
 The United Horse Shoe and Nail Co., Limited, 115 Cannon st., E. C., London.

**HORSE SHOES.**  
**BREYER MODEL HORSE SHOE WORKS, LIMITED**, Catsaqua, Pa. (General Sales Agent—J. B. White, 184 West st., New York).  
 Howard, Childs & Co., Hamilton Bldg., Pittsburgh, Pa.  
**PUGH & RUSSELL, Stewart Bldg.**, New York; Phoenix Bldg., Chicago, Ill.  
 The United Horse Shoe and Nail Co., Limited, 115 Cannon st., E. C., London.

**HORSE SHOE VISES.**  
 Burke, F. F., 360 Dorchester av., Boston, Mass. (vide Toe Calks).

**HYDRAULIC JACKS.**  
 Brill (J. G.) Co., Philadelphia.  
 Greeley, The E. S., & Co., 5 and 7 Dey st., New York.  
 Howard, Childs & Co., Hamilton Bldg., Pittsburgh, Pa.  
 Post & Company, Cincinnati, Ohio.  
**PUGH & RUSSELL, Stewart Bldg.**, New York; Phoenix Bldg., Chicago, Ill.  
 Watson & Stillman, 210 E. 43rd st., New York.

**JOINT PLATES.**  
**WAY FOUNDRY CO. (The)**, 23rd and Wood sts., Phila.

**JOURNAL BOXES.**  
**ANDREWS, FRANK H.**, 545 W. 33rd st., New York (vide Brake).  
**BAKER, W. S. GRAFF**, care Brown, Shipley & Co., London (vide Car Starters).

**BALTIMORE CAR WHEEL CO. (The)**, Baltimore, Md. (vide Car Wheels).  
**BEMIS & WILSON**, 407 Springfield, Mass.  
 Brill (J. G.) Co., Philadelphia.  
**BROOKLYN RAILWAY SUPPLY CO. (The)**, 44 Walworth st., Brooklyn, N. Y.  
**BROWNELL & WIGHT CAR CO.**, 2300 Broadway, St. Louis, Mo.  
 Chapin Mfg. Co., 69 Wall st., New York.  
 Chester Steel Castings Co., 407 Library st., Philadelphia.  
**FULTON FOUNDRY**, Cleveland, Ohio (vide Axles).  
 Greeley, The E. S., & Co., 5 and 7 Dey st., New York.  
 Howard, Childs & Co., Hamilton Bldg., Pittsburgh, Pa.  
 Keystone Smelting Co. (The), Limited, 33rd st., Philadelphia.  
 Laeide Car Co., 4500 N. Second st., St. Louis, Mo.  
**LEWIS & FOWLER MFG. CO. (The)**, 27 to 35 Walworth st., Brooklyn, N. Y.  
**MARTIN, RUFUS, & CO.**, 13 Park Row, New York (vide Bearings).  
 Miller, Chas. B., 310 E. 14th st., New York.  
 Post & Company, Cincinnati, Ohio.  
**PUGH & RUSSELL, Stewart Bldg.**, New York; Phoenix Bldg., Chicago, Ill.  
**SNEAD & BIBB**, Louisville, Ky.  
**STREET RAILWAY SUPPLY CO.**, Cleveland, Ohio.  
 VanDuzen & Tift, 102 and 104 E. 2nd st., Cincinnati, Ohio.  
 Wm. Wharton, Jr., & Co. (Incorporated), 25th st. and Washington ave., Philadelphia, Pa.  
 Whiting Mfg. Co., Cedar Rapids, Iowa.  
**WHITNEY, A. & SONS**, Philadelphia, Pa.

**KNIVES.**  
 ANDREWS, FRANK H., 545 W. 33rd st., New York (vide Brake).  
**WAY FOUNDRY CO. (The)**, 23rd and Wood sts., Philadelphia, Pa.

**LAMP TERMINUS.**  
**ADAMS & WESTLAKE CO. (The)**, 110 Ontario st., Chicago, Ill.; 115 Broadway, New York.  
 Post & Company, Cincinnati, Ohio.

**MOTORS.**  
 Brill (J. G.) Co., Philadelphia, Pa.  
**MARTIN, RUFUS, & CO.**, 13 Park Row, New York (vide Bearings).  
**PUGH & RUSSELL, Stewart Bldg.**, New York; Phoenix Bldg., Chicago, Ill.  
 Standard Oil Co., 12 Chartres st., New Orleans, La.  
 Pole-Ste. Car Motor System, 310 Chestnut, Philadelphia.

**MOTORS (Electric).**  
**BENTLEY-KNIGHT ELECTRIC RAILWAY CO.**, 115 Broadway, New York.  
 Cleveland Electric Motor Co., First Nat'l Bank Bldg., Cleveland, Ohio. (vide Contractors).  
**DAFT ELECTRIC ENGINE CO. (The)**, 115 Broadway, New York.  
 Greeley, The E. S., & Co., 5 and 7 Dey st., New York.  
**HORACE A. KEEFER CO. (The)**, Kansas City, Mo.  
 Julian Electric Co., 120 Broadway, New York.  
**MARTIN, RUFUS, & CO.**, 13 Park Row, New York (vide Bearings).  
**PUGH & RUSSELL, Stewart Bldg.**, New York; Phoenix Bldg., Chicago, Ill.

**SARCEY ELECTRIC CONSTRUCTION CO. (DAFT SYSTEM)**, 41 Wall st., New York.  
**SPRAGUE ELECTRIC RAILWAY & MOTOR CO.**, 16 and 18 Broad st., New York (vide Electric Railways).  
**VAN DEPOELE ELECTRIC MFG. CO.**, 15 to 21 Clinton st., Chicago, Ill. (Branch—45 Broadway, N. Y.).

**MOTORS (Gas).**  
 The Connelly Motor Co., 177 Broadway, New York.

**MOTORS (Steam).**  
**BALDWIN LOCOMOTIVE WORKS**, Philadelphia.  
 Black & White, 407 Greenes-st., Tyne, England.  
 Dick, Kerr & Co., 101 Leadenhall st., E. C. London (vide Car Builders).  
 Falcon Engine & Car Works, Limited, Longborough, Eng. (London Office—41 Coleman st., E. C.).  
 Greeley, The E. S., & Co., 5 and 7 Dey st., New York.  
 Gurney & Sons, Limited, 30, Sheffield Iron Works, Leeds, & Surrey Works, Beckwith Road, S. E., London.  
 Henschel & Sohn, Cassel, Germany.  
 New York Safety Steam Power Co., 64 S. Canal st., Chicago.  
 Porter, C. & Co., Pittsburgh, Pa.  
**PUGH & RUSSELL, Stewart Bldg.**, New York; Phoenix Bldg., Chicago, Ill.

**OFFICE FURNITURE, Etc.**  
 The Globe Co., Cincinnati, Ohio.  
**OIL AND DUST TIGHT CAR GEARING.**  
**BALTIMORE CAR WHEEL CO. (The)**, Baltimore, Md. (vide Car Wheels).

**OILS.**  
 Dunne & Tison & Co., Dashwood House, New Broad st., E. C., London.  
 Vacuum Oil Co., Rochester, N. Y. (Branches—208 Home Ave., Buffalo, N. Y.; 100 Broadway, New York; 100 N. La Salle, Chicago; 96 Water st., New York; 17 Com. Gas Bldg., Cincinnati; 45 Purchase st., Boston; 150 First St., Pittsburgh; 305 Water st., Philadelphia; 2164 Wash. av., St. Minneapolis; 97 Smith's Whf., Baltimore, Md.; 138 St. James st., Montreal, and 96 King st., West, Toronto, Canada.).

**OMNIBUS HARDWARE.**  
**ADAMS & WESTLAKE CO. (The)**, 110 Ontario st., Chicago, Ill.; 115 Broadway, New York.

**PAINTS.**  
 Brill (J. G.) Co., Philadelphia.  
**BROWNELL & WIGHT CAR CO.**, 2300 Broadway, St. Louis, Mo.  
**CHICAGO WOOD FINISHING CO.**, 143 and 145 S. Chicago, Chicago, Ill.  
**COFFIN, DEVON & CO.**, 176 Randolph st., Chicago, Ill.  
**IRON CLAD PAINT CO.**, 3 Case Bldg., Cleveland, O.  
 Laeide Car Co., 4500 N. Second st., St. Louis, Mo.  
 Lowes Metallic Paint Co., Chicago, Ill.  
**MARTIN, RUFUS, & CO.**, 13 Park Row, New York (vide Bearings).  
 Peabody, Hy. W., & Co., Mason Building Boston. (Branches—81 New st., New York; Leadenhall House, Leadenhall st., E. C. London, Eng.).  
 Post & Company, Cincinnati, Ohio.  
**PUGH & RUSSELL, Stewart Bldg.**, New York; Phoenix Bldg., Chicago, Ill.  
 Sherwin-Williams Co. (The), Cleveland, Ohio (vide Colors).  
 VanDuzen & Tift, 102 and 104 E. 2nd st., Cincinnati, Ohio.  
 Watson & Stillman, 210 E. 43rd st., New York. (Branches—68 Lake st., Chicago; 153 Milk st., Boston; 21 Rue de Lappe, Paris.).

**PANELS.**  
 Brill (J. G.) Co., Philadelphia.  
**BROWNELL & WIGHT CAR CO.**, 2300 Broadway, St. Louis, Mo.  
**REHMANN CAR CO.**, 490 St. Clair st., Cleveland, O.  
 Laeide Car Co., 4500 N. Second st., St. Louis, Mo.  
**MARTIN, RUFUS, & CO.**, 13 Park Row, New York (vide Bearings).  
**PUGH & RUSSELL, Stewart Bldg.**, New York; Phoenix Bldg., Chicago, Ill.

**PEDESTALS.**  
**ANDREWS, FRANK H.**, 545 W. 33rd st., New York (vide Brake).  
 Ayres, Abraham, 502 to 518 W. 45th st., New York.  
**BALTIMORE CAR WHEEL CO. (The)**, Baltimore, Md. (vide Car Wheels).  
**BEMIS & WILSON**, 407 Springfield, Mass.  
 Brill (J. G.) Co., Philadelphia.  
**BROWNELL & WIGHT CAR CO.**, 2300 Broadway, St. Louis, Mo.  
**FULTON FOUNDRY**, Cleveland, Ohio (vide Axles).  
 Laeide Car Co., 4500 N. Second st., St. Louis, Mo.  
**LEWIS & FOWLER MFG. CO. (The)**, 27 to 35 Walworth st., Brooklyn, N. Y.  
**PUGH & RUSSELL, Stewart Bldg.**, New York; Phoenix Bldg., Chicago, Ill.  
**SNEAD & BIBB**, Louisville, Ky.  
**STREET RAILWAY SUPPLY CO.**, Cleveland, Ohio.  
 Wm. Wharton, Jr., & Co. (Incorporated), 25th st. and Washington ave., Philadelphia, Pa.  
**WHITNEY, A. & SONS**, Philadelphia, Pa.

**PHOSPHOR BRONZE.**  
 Tabal Smelting Works, 700 So. Broadway, Philadelphia, Pa.

**PHOSPHOR BRONZE CABLE GRIPS.**  
 Van Duzen & Tift, 102 and 104 E. 2nd st., Cincinnati, Ohio.

**POLISHES.**  
**CHICAGO WOOD FINISHING CO.**, 143 and 145 S. Chicago, Ill.  
 Clark, J. C., 275 and 279 S. Canal st., Chicago.  
 Gould, J. H., & Gould & Co., Philadelphia (vide Grips).  
**MARTIN, RUFUS, & CO.**, 13 Park Row, New York (vide Bearings).  
**PUGH & RUSSELL, Stewart Bldg.**, New York; Phoenix Bldg., Chicago, Ill.

**POLISHING MACHINERY.**  
 Watson & Stillman, 210 E. 43rd st., New York.

**PRESSES (Car Wheel).**  
**ANDREWS, FRANK H.**, 545 W. 33rd st., New York (vide Brake).  
 Brill (J. G.) Co., Philadelphia.  
 Greeley, The E. S., & Co., 5 and 7 Dey st., New York.  
**PUGH & RUSSELL, Stewart Bldg.**, New York; Phoenix Bldg., Chicago, Ill.  
 Watson & Stillman, 210 E. 43rd st., New York.

**PULLEYS AND SHEAVES.**  
**LANE & BODLEY CO. (The)**, 267-283 Water st., Cincinnati, Ohio.  
**POOLE & HUNT**, Baltimore, Md. (vide Grips).

**PUNCHES AND SHEARS.**  
 Watson & Stillman, 210 E. 43rd st., New York.  
**RAILWAY REGISTER MFG. CO.**, 1193 Broadway, New York (vide Register Punches).

**PURCHASING AGENTS.**  
 Peabody, Henry W., & Co., Boston (vide Paints).

**RAILS (Curved).**  
**ANDREWS, FRANK H.**, 545 W. 33rd st., New York (vide Brake).  
 Ayres, Abraham, 502 to 518 W. 45th st., New York.  
 Craig, Wm. P., 95 Liberty st., New York.  
**FULTON FOUNDRY**, Cleveland, O. (vide Axles).  
**HORACE A. KEEFER CO. (The)**, Kansas City, Mo.  
 Howard, Childs & Co., Hamilton Bldg., Pittsburgh, Pa.  
**JOHNSTON STEEL STREET RAIL CO. (The)**, Johnstown, Pa. (vide Cable Yokes).  
**LEWIS & FOWLER MFG. CO. (The)**, 27 to 35 Walworth st., Brooklyn, N. Y.  
**LONGSTREET, D. F.**, Providence, R. I. (Agents—Wm. Wharton, Jr., & Co. (Incorporated), Philadelphia).  
 Metcalf Street Railway Supply Co., Albany, N. Y. (vide Cable Yokes).  
 Pennsylvania Steel Co., Philadelphia (vide Axles).  
**PUGH & RUSSELL, Stewart Bldg.**, New York; Phoenix Bldg., Chicago, Ill.  
 St. Thomas Car Wheel Co., St. Thomas, Ont., Canada.  
**STREET RAILWAY SUPPLY CO.**, Cleveland, Ohio.  
 Wm. Wharton, Jr., & Co. (Incorporated), 25th st. and Washington ave., Philadelphia, Pa.  
 Whiting Manufacturing Co., Cedar Rapids, Iowa.

**RAILS (Steel).**  
**ANDREWS, FRANK H.**, 545 W. 33rd st., New York (vide Brake).  
 Ayres, Abraham, 502 and 518 W. 45th st., New York.  
 Cambria Iron Co., 215 S. 4th st., Philadelphia (vide Axles).  
 Carnegie, Phillips & Co., Limited, 43 Fifth ave., Pittsburgh, Pa.  
 Craig, Wm. P., 95 Liberty st., New York.  
 Erleigh, Gen. M., 204 N. Third st., St. Louis, Mo.  
**FULTON FOUNDRY**, Cleveland, O. (vide Axles).  
**HORACE A. KEEFER CO. (The)**, Kansas City, Mo.  
 Howard, Childs & Co., Hamilton Bldg., Pittsburgh, Pa.  
**JOHNSTON STEEL STREET RAIL CO. (The)**, Johnstown, Pa. (Branches—Cotton Exchange Bldg., New Orleans; Phoenix Bldg., Chicago; Bank of Commerce Bldg., St. Louis; 25th st., New York; Stewart Bldg., New York; Johnston Bldg., Cincinnati; 252 W. Main st., Louisville, Ky.).  
**LONGSTREET, D. F.**, Providence, R. I. (Agents—Wm. Wharton, Jr., & Co., Philadelphia, Pa.).  
 Metcalf Street Railway Supply Co., Albany, N. Y. (vide Cable Yokes).  
 North Chicago Rolling Mill Co., 17 Metropolitan block, Chicago. (Branch—New Insurance Bldg., Milwaukee).  
 Pennsylvania Steel Co., Philadelphia (vide Axles).  
 Post & Company, Cincinnati, Ohio.  
**PUGH & RUSSELL, Stewart Bldg.**, New York; Phoenix Bldg., Chicago, Ill.  
 Springfield Iron Co. (The), Springfield, Ill. (Branch—Horse, Leadenhall st., E. C. London, Eng.).  
**STREET RAILWAY SUPPLY CO.**, Cleveland, Ohio.  
 Wm. Wharton, Jr., & Co. (Incorporated), 25th st. and Washington ave., Philadelphia, Pa.  
 Worcester Steel Works, Worcester, Mass.

**RAILS (Tram and T).**  
**HATHAWAY & ROBINSON**, 14 Case Bldg., Cleveland, O.  
 Tator Iron Works, 509 N. 3d st., St. Louis, Mo.



**RAILWAYS (Cable) BUILDERS.**  
**ANDREWS, FRANK H.**, 545 W. 33rd st., New York (vide Brakes).  
**BAKER, W. S.**, GRAFF, care Brown, Shipley & Co., London (vide Car Starters).  
 Gould, J. H., & Gould & Co., Philadelphia. (vide Grips).  
 Miller, D. J., Broadway Supply Co., Albany, N. Y. (vide Cable Yokes).  
**MILLER, J. J.**, 234 Broadway, New York.  
 National Cable Co., 140 Nassau st., New York.  
 Patent Cable Tramways Corporation, Limited, Victoria Mansions, Westminster, S. W., London.  
 Rasmussen Cable Co. (The), Room 606 First National Bank, Chicago, Ill.  
 Wm. Wharton, Jr., & Co. (Incorporated), 25th st. and Washington ave., Philadelphia, Pa.

**RAILWAYS (Electric) BUILDERS.**  
**BENTLEY-KNIGHT ELECTRIC RAILWAY CO.**, 115 Broadway, New York.  
 Chabourne & Hays (Agents for Sprague motors), 119 S. 4th st., Philadelphia.  
 Cleveland Electric Motor Co. (vide Contractors and Builders).  
**DAFT ELECTRIC LIGHT CO.** (The), 115 Broadway, New York.

Harris, T. Wm., & Co., 2 Nassau st., room 17, New York.  
 Henry Electric Railway Co. (The), Kansas City, Mo.  
 Julien Electric Co., 120 Broadway, New York.  
 Metallic Street Railway Supply Co., Albany, N. Y. (vide Cable Yokes).

**SAFETY ELECTRIC CONSTRUCTION CO. (DAFT SYSTEM)**, 41 Wall st., New York.  
**SPRAGUE ELECTRIC RAILWAY MOTOR CO.**, 16 and 18 Broad st., New York.  
 U. S. Electric Co., Denver, Col.  
**VAN DER POELE ELECTRIC MANUFACTURING CO.**, 15 to 21 N. E. Second st., Chicago, Ill.  
 Wm. Wharton, Jr., & Co. (Incorporated), 25th st. and Washington ave., Philadelphia, Pa.

**RAILWAY (Horse) BUILDERS.**  
**BAKER, W. S.**, GRAFF, care Brown, Shipley & Co., London (vide Car Starters).  
 Craig, Wm. F., 95 Liberty st., New York.  
 Harris, T. Wm., & Co., Nassau st., room 17, New York.  
**JOHNSTON STEEL STREET RAIL CO.** (The), Johnson-st., Albany, N. Y.  
**LEWIS & FOWLER MFG. CO.** (The), 27 to 35 Walworth st., Brooklyn, N. Y.  
**MARTIN, RUFUS & CO.**, 13 Park Row, New York (vide Bearings).  
 Metallic St. Ry. Supply Co., Albany, N. Y. (vide Cable Yokes).  
 Wm. Wharton, Jr., & Co. (Incorporated), 25th st. and Washington ave., Philadelphia, Pa.

**RAILWAYS (Steam) BUILDERS.**  
 Harris, T. Wm., & Co., 2 Nassau st., room 17, New York.  
 Metallic St. Ry. Supply Co., Albany, N. Y. (vide Cable Yokes).  
 Wm. Wharton, Jr., & Co. (Incorporated), 25th st. and Washington ave., Philadelphia, Pa.

**REGISTERING PUNCHES (Alarm).**  
**RAILWAY REGISTERING MFG. CO.**, 1193 Broadway, New York (vide Fare Registers).

**ROAD CEMENTS.**  
 Empire Warehouse Co., 198-204 Market st., Chicago, Ill.  
 Peabody, Hunt, W., & Co., Boston (vide Patrs).

**ROUGH STUFF.**  
**CHICAGO WOOD FINISHING CO.**, 143 and 145 S. Clinton st., Chicago, Ill.

**RUBBER TREADS (For Car Steps).**  
 Rubber Step Mfg. Co., 43 Haverhill st., Boston, Mass.  
**SAFETY PULL IRONS.**  
 Brill (J. G.) Co., Philadelphia.

**LAND BOXES.**  
 Brill (J. G.) Co., Philadelphia.  
**CAR TRACK FRICTION APPLIANCE CO.** (The), 19 Tremont Bldg., Boston, Mass. (W. T. Butler, general manager).  
 Jordan Mills Mfg. Co. (The), 32 Nassau st., New York.  
 Laclede Car Co., 4500 N. Second st., St. Louis, Mo.  
**LEWIS & FOWLER MFG. CO.** (The), 27 to 35 Walworth st., Brooklyn, N. Y.  
**PUGH & RUSSELL, Stewart Bldg.**, New York; Phoenix Bldg., Chicago, Ill.

**SEATS AND SEAT SPRINGS.**  
 Brill (J. G.) Co., Philadelphia.  
**BROWNELL & WIGHT CAR CO.**, 2300 Broadway, St. Louis, Mo.  
 Dayton Mfg. Co. (The), Dayton, Ohio.  
 Greeley, The E. S., & Co., 5 and 7 Dey st., New York.  
 Hale & Kilburn Mfg. Co. (The), 48 and 50 N. 6th st., Philadelphia.  
**HARTFORD GROVEN WIRE MATTRESS CO.** (The), P. O. Box 363, Hartford, Conn.  
 Laclede Car Co., 4500 N. Second st., St. Louis, Mo.  
**MARTIN, RUFUS & CO.**, 13 Park Row, New York (vide Bearings).  
 Post & Company, Cincinnati, Ohio.  
**PUGH & RUSSELL, Stewart Bldg.**, New York; Phoenix Bldg., Chicago, Ill.

**SHAFTING HANGERS AND PULLEYS.**  
 LANK & BODLEY CO. (The), 267-283 Water st., Cincinnati, Ohio.

**SIGNAL LIGHTS.**  
**ADAMS & WESTLAKE CO.** (The), 110 Ontario st., Chicago, Ill.; 115 Broadway, New York.  
 Brill (J. G.) Co., Philadelphia.  
**BROWNELL & WIGHT CAR CO.**, 2300 Broadway, St. Louis, Mo.  
 Greeley, The E. S., & Co., 5 and 7 Dey st., New York.  
 Laclede Car Co., 4500 N. Second st., St. Louis, Mo.  
**LEWIS & FOWLER MFG. CO.** (The), 27 to 35 Walworth st., Brooklyn, N. Y.  
**MARTIN, RUFUS & CO.**, 13 Park Row, New York (vide Bearings).  
 Post & Company, Cincinnati, Ohio.  
**PUGH & RUSSELL, Stewart Bldg.**, New York; Phoenix Bldg., Chicago, Ill.

**SNOW PLOWS.**  
**ANDREWS, FRANK H.**, 545 W. 33rd st., New York (vide Brakes).  
 Brill (J. G.) Co., Philadelphia.  
**BROOKLYN RAILWAY SUPPLY CO.** (The), 44 Walworth st., Brooklyn, N. Y.  
 Craig, Wm. F., 95 Liberty st., New York.  
 Day, Augustus, 22 Park Place, Detroit, Mich.  
**JOHNSTON STEEL STREET RAIL CO.** (The), Johnson-st., Albany, N. Y.  
**LEWIS & FOWLER MFG. CO.** (The), 27 to 35 Walworth st., Brooklyn, N. Y.  
**MARTIN, RUFUS & CO.**, 13 Park Row, New York (vide Bearings).  
**PUGH & RUSSELL, Stewart Bldg.**, New York; Phoenix Bldg., Chicago, Ill.

**SPIKES AND FASTENINGS.**  
 Craig, Wm. F., 95 Liberty st., New York.  
**FULTON FOUNDRY**, Cleveland, O. (vide Axles).  
 Greeley, The E. S., & Co., 5 and 7 Dey st., New York.  
**HATHAWAY & ROBINSON**, 14 Case Bldg., Cleveland, O.  
**HORACE A. KEEFER CO.** (The), Kansas City, Mo.  
 Howard, Childs & Co., Hamilton Bldg., Pittsburgh, Pa.  
**JOHNSTON STEEL STREET RAIL CO.** (The), Johnson-twn, Pa. (vide Rails, Steel).  
**LEWIS & FOWLER MFG. CO.** (The), 27 to 35 Walworth st., Brooklyn, N. Y.  
 Post & Company, Cincinnati, Ohio.  
**PUGH & RUSSELL, Stewart Bldg.**, New York; Phoenix Bldg., Chicago, Ill.  
 Tuntor Iron Works, 509 N. 3rd st., St. Louis, Mo.  
 Wm. Wharton, Jr., & Co. (Incorporated), 25th st. and Washington ave., Philadelphia, Pa.

**SPICES FOR JOINING WIRE CABLES.**  
**HARDY MANUFACTURING CO.** (The), Wilkes Barre, Pa. (vide Cables).  
**SPRING STEEL.**  
 Cambria Iron Co., 218 S. 4th st., Philadelphia. (vide Axles).

**STAINS.**  
**CHICAGO WOOD FINISHING CO.**, 143 and 145 S. Clinton st., Chicago, Ill.

**STATIONARY ENGINE BUILDERS.**  
 Buckeye Engine Co., Salem, Ohio. (Sales Agents—W. L. Simpson, 301 Telephone Building, 18 Cortland st., Cleveland, Ohio; J. E. P. 30 Ohio st., London, Mass.; N. W. Robinson, cor. Clinton and Jackson sts., Chicago, Ill.; Robinson & Corey, St. Paul, Minn.; G. S. Johnson, Worcester, Mass.).  
 Fishkill Landing Machine Co., Fishkill-on-the-Hudson, Harris, Wm. A., Providence, R. I.  
 Hooven, Owens & Reentscher Co. (The), Hamilton, O.  
**HORACE A. KEEFER CO.** (The), Kansas City, Mo.  
 Keesler, Chas., & Co., 303 S. Canal st., Chicago.  
**LANK & BODLEY CO.** (The), 267-283 Water st., Cincinnati, Ohio.  
 New York Safety Steam Power Co., 64 S. Canal st., Chicago.  
 Noye, The J. T., Manufacturing Co., Buffalo, N. Y. (Branches at Chicago, Ill., and Minneapolis, Minn.).  
 Providence Engine Works, Providence, R. I.  
 Whitling Manufacturing Co., Cedar Rapids, Iowa.

**STEAM BOILERS.**  
 Heller, Sauter & Bolles Co., 102 North Main st., St. Louis, Mo. (Agent—J. H. Harris, 82 Madison st., Chicago).  
 Hooven, Owens & Reentscher Co. (The), Hamilton, O.

**STORAGE BATTERIES (for Lights, &c.)**  
 Julien Electric Co., 120 Broadway, New York.

**SUPPLIES (General).**  
**ANDREWS, FRANK H.**, 545 W. 33rd st., New York (vide Brakes).  
 Brill (J. G.) Co., Philadelphia.  
**BROOKLYN RAILWAY SUPPLY CO.** (The), 44 Walworth st., Brooklyn, N. Y.  
**BROWNELL & WIGHT CAR CO.**, 2300 Broadway, St. Louis, Mo.  
 Chester Steel Castings Co., 407 Library st., Philadelphia.  
 Child, O. W., & Co., 150 Broadway, New York.  
 Craig, Wm. F., 95 Liberty st., New York.  
 Dwight, E. P., 407 Library st., Philadelphia.  
 Greeley, The E. S., & Co., 5 and 7 Dey st., New York.  
**HARTFORD GROVEN WIRE MATTRESS CO.** (The), P. O. Box 363, Hartford, Conn.  
**HATHAWAY & ROBINSON**, 14 Case Bldg., Cleveland, O.  
 Howard, Childs & Co., Hamilton Building, Pittsburgh, Pa.  
 Jessup, F. W., & Co., 61 Liberty st., New York.  
**JOHNSTON STEEL STREET RAIL CO.** (The), Johnson-twn, Pa. (vide Rails, Steel).  
 Kimbark, S. D., Michigan ave. and Lake st., Chicago, Ill.  
**LEWIS & FOWLER MFG. CO.** (The), 27 to 35 Walworth st., Brooklyn, N. Y.  
**MARTIN, RUFUS & CO.**, 13 Park Row, New York (vide Bearings).  
 Metallic Street Railway Supply Co. (The), Albany, N. Y.  
 Phoenix Steel Wire Broom & Brush Co., 199 E. Randolph st., Chicago, Ill.  
 Post & Company, Cincinnati, Ohio.  
**PUGH & RUSSELL, Stewart Bldg.**, New York; Phoenix Bldg., Chicago, Ill.  
 Saxton, J. C., 52 Broadway, New York.  
**SMITH, JOSEPHINE D.**, 350 Pearl st., New York.  
**STREPHENSON JOHN COMPANY**, Ltd., New York.  
**STREET RAILWAY SUPPLY CO.**, Cleveland, Ohio.  
 Wm. Wharton, Jr., & Co. (Incorporated), 25th st. and Washington ave., Philadelphia, Pa.  
 White, Edward C., 530 W. 33rd st., New York.

**SWEEEPING MACHINES (Dirt or Street).**  
**BROOKLYN RAILWAY SUPPLY CO.** (The), 44 Walworth st., Brooklyn, N. Y.

**SWITCH CASTINGS.**  
**HATHAWAY & ROBINSON**, 14 Case Bldg., Cleveland, O.

**SWITCH ROPES.**  
**ROEBLING'S SONS CO., JOHN A.**, 117 and 119 Liberty st., New York.

**SWITCHES.**  
**ANDREWS, FRANK H.**, 545 W. 33rd st., New York (vide Brakes).  
 Ayres, Abraham, 502 to 518 W. 45th st., New York.  
**BALTIMORE CAR WHEEL CO.** (The), Baltimore, Md. (vide Car Wheels).  
 Craig, Wm. F., 95 Liberty st., New York.  
**FULTON FOUNDRY**, Cleveland, O. (vide Axles).  
 Greeley, The E. S., & Co., 5 and 7 Dey st., New York.  
 Howard, Childs & Co., Hamilton Building, Pittsburgh, Pa.  
**JOHNSTON STEEL STREET RAIL CO.** (The), Johnson-twn, Pa. (vide Rails, Steel).  
 Johnston Railroad Frog & Switch Co., 307 Walnut st., St. Louis, Mo.  
**LEWIS & FOWLER MFG. CO.** (The), 27 to 35 Walworth st., Brooklyn, N. Y.  
 Metallic St. Ry. Supply Co., Albany, N. Y. (vide Cable Yokes).  
 Pennsylvania Steel Co., Philadelphia (vide Axles).  
**PUGH & RUSSELL, Stewart Bldg.**, New York; Phoenix Bldg., Chicago, Ill.  
**SNEAD & BIBB**, Louisville, Ky.  
**W. F. FOUNDRY CO.** (The), 23rd and Wood sts., Philadelphia, Pa.  
 Wm. Wharton, Jr., & Co. (Incorporated), 25th st. and Washington ave., Philadelphia, Pa.  
**WHITE, M. C.**, 531 W. 33rd st., New York.  
 Whitney Mfg. Co., Cedar Rapids, Iowa.

**SWITCHES (Automatic).**  
**ANDREWS, FRANK H.**, 545 W. 33rd st., New York (vide Brakes).  
 Ayres, Abraham, 502 to 518 W. 45th st., New York.  
 Craig, Wm. F., 95 Liberty st., New York.  
**FULTON FOUNDRY**, Cleveland, O. (vide Axles).  
 Greeley, The E. S., & Co., 5 and 7 Dey st., New York.

**HATHAWAY & ROBINSON**, Room 14 Case Building, Cleveland, Ohio.  
**HORACE A. KEEFER CO.** (The), Kansas City, Mo.  
**JOHNSTON STEEL STREET RAIL CO.** (The), Johnson-twn, Pa. (vide Rails, Steel).  
**LEWIS & FOWLER MFG. CO.** (The), 27 to 35 Walworth st., Brooklyn, N. Y.  
 Metallic St. Ry. Supply Co., Albany, N. Y. (vide Cable Yokes).  
**PUGH & RUSSELL, Stewart Bldg.**, New York; Phoenix Bldg., Chicago, Ill.  
 Wm. Wharton, Jr., & Co. (Incorporated), 25th st. and Washington ave., Philadelphia, Pa.  
**WHITE, M. C.**, 531 W. 33rd st., New York.

**TENSION CARRIAGES.**  
 BOELL & HUNT, Baltimore, Md. (vide Grips).  
**TRUCKETS.**  
 Fullerton (The), Limited, 24 Tabernacle st., Finsbury sq., E. C. London.  
 Foster, C. A., Mercers' Row, Northampton, England.  
 W. W. W. Stationery & Printing Co., Dearborn st., Chicago, Ill.  
 Whiting T. J., 7A South Place, Finsbury, E. C. London.

**TRUCK PLATES.**  
**JOHNSTON STEEL STREET RAIL CO.** (The), Johnson-twn, Pa. (vide Rails, Steel).

**TIE RODS.**  
**JOHNSTON STEEL STREET RAIL CO.** (The), Johnson-twn, Pa. (vide Rails, Steel).

**TOE CALKS.**  
**BURTON & CO.**, Dorchester ave., Boston, Mass. (Agents—Kelly, Maus & Co., Chicago, Ill.; Livingstone Horse Nail Co., New York, N. Y.)  
 Cambria Iron Co., 218 S. 4th st., Philadelphia (vide Axles).  
 Howard, Childs & Co., Hamilton Building, Pittsburgh, Pa.  
**PUGH & RUSSELL, Stewart Bldg.**, New York; Phoenix Bldg., Chicago, Ill.

**TOOLS (Track and Stable).**  
**BROOKLYN RAILWAY SUPPLY CO.** (The), 44 Walworth st., Brooklyn, N. Y.  
 Craig, Wm. F., 95 Liberty st., New York.  
 Greeley, The E. S., & Co., 5 and 7 Dey st., New York.  
 Howard, Childs & Co., Hamilton Building, Pittsburgh, Pa.  
 Lee & Hunt, Arkwright Works, Nottingham, England.  
**LEWIS & FOWLER MFG. CO.** (The), 27 to 35 Walworth st., Brooklyn, N. Y.  
**MARTIN, RUFUS & CO.**, 13 Park Row, New York (vide Bearings).  
 Post & Company, Cincinnati, Ohio.  
**PUGH & RUSSELL, Stewart Bldg.**, New York; Phoenix Bldg., Chicago, Ill.

**STREET RAILWAY SUPPLY CO.**, Cleveland, Ohio.  
 Wm. Wharton, Jr., & Co. (Incorporated), 25th st. and Washington ave., Philadelphia, Pa.

**TRACK CASTINGS.**  
**ANDREWS, FRANK H.**, 545 W. 33rd st., New York (vide Brakes).  
 Ayres, Abraham, 502 to 518 W. 45th st., New York.  
**BALTIMORE CAR WHEEL CO.** (The), Baltimore, Md. (vide Car Wheels).  
 Chester Steel Castings Co., 407 Library st., Philadelphia.  
 Craig, Wm. F., 95 Liberty st., New York.  
**FULTON FOUNDRY**, Cleveland, Ohio (vide Axles).  
**HORACE A. KEEFER CO.** (The), Kansas City, Mo.  
 Howard, Childs & Co., Hamilton Building, Pittsburgh, Pa.  
**JOHNSTON STEEL STREET RAIL CO.** (The), Johnson-twn, Pa. (vide Rails, Steel).  
**LEWIS & FOWLER MFG. CO.** (The), 27 to 35 Walworth st., Brooklyn, N. Y.  
**MARTIN, RUFUS & CO.**, 13 Park Row, New York (vide Bearings).  
 Metallic Street Railway Supply Co., Albany, N. Y. (vide Cable Yokes).

**WIRE BROOM & BRUSH CO.**, 199 E. Randolph st., Chicago, Ill.  
**PUGH & RUSSELL, Stewart Bldg.**, New York; Phoenix Bldg., Chicago, Ill.  
 St. Thomas Car Wheel Co., St. Thomas, Ont., Canada.  
**STREET RAILWAY SUPPLY CO.**, Cleveland, Ohio.  
 HAD & HUBBARD, New York.  
**W. F. FOUNDRY CO.** (The), 23rd and Wood sts., Philadelphia, Pa.

Wm. Wharton, Jr., & Co. (Incorporated), 25th st. and Washington ave., Philadelphia, Pa.  
 Whitling Mfg. Co., Cedar Rapids, Iowa.  
**WHITNEY, A.**, & SONS, Philadelphia, Pa.

**TRACK SCRAPERS.**  
**ANDREWS, FRANK H.**, 545 W. 33rd st., New York (vide Brakes).  
 Brill (J. G.) Co., Philadelphia.  
 Craig, Wm. F., 95 Liberty st., New York.  
 Day, Augustus, 22 Park Place, Detroit, Mich.  
 Greeley, The E. S., & Co., 5 and 7 Dey st., New York.  
 Howard, Childs & Co., Hamilton Building, Pittsburgh, Pa.  
 Laclede Car Co., 4500 N. Second st., St. Louis, Mo.  
**LEWIS & FOWLER MFG. CO.** (The), 27 to 35 Walworth st., Brooklyn, N. Y.  
**PUGH & RUSSELL, Stewart Bldg.**, New York; Phoenix Bldg., Chicago, Ill.

**STREET RAILWAY SUPPLY CO.**, Cleveland, Ohio.  
**WHITE, M. C.**, 531 W. 33rd st., New York.

**TRANSFER TABLES.**  
 Brill (J. G.) Co., Philadelphia.  
 Craig, Wm. F., 95 Liberty st., New York.  
**FULTON FOUNDRY**, Cleveland, Ohio (vide Axles).  
**HATHAWAY & ROBINSON**, 14 Case Bldg., Cleveland, O.  
**HORACE A. KEEFER CO.** (The), Kansas City, Mo.  
**LEWIS & FOWLER MFG. CO.** (The), 27 to 35 Walworth st., Brooklyn, N. Y.  
**PUGH & RUSSELL, Stewart Bldg.**, New York; Phoenix Bldg., Chicago, Ill.

**STREET RAILWAY SUPPLY CO.**, Cleveland, Ohio.  
 Wm. Wharton, Jr., & Co. (Incorporated), 25th st. and Washington ave., Philadelphia, Pa.

**TRANSIT.**  
**ALOE, A. S.**, & Co., 300 N. Fourth st., St. Louis, Mo.



**TURN OUTS.**  
**ANDREWS, FRANK H.**, 545 W. 33rd st., New York (vide Brakes).  
 Craig Wm. P., 95 Liberty st., New York.  
**PULFRIE FOUNDRY**, Cleveland, O. (vide Axes).  
**HORACE A. KEEFER CO.** (The), Kansas City, Mo.  
**JOHNSTON STEEL STREET RAIL CO.** (The), Johnstown, Pa.  
**LEWIS & FOWLER MFG. CO.** (The), 27 to 35 Walworth st., Brooklyn, N. Y.  
**McCallie St. Railway Supply Co.**, Albany, N. Y. (vide Cable Yokes).  
**PUGH & RUSSELL**, Stewart Bldg., New York; Phoenix Bldg., Chicago, Ill.  
**St. Thomas Car Wheel Co.**, St. Thomas, Ont., Canada.  
**STREET RAILWAY SUPPLY CO.**, Cleveland, Ohio.  
**WAY FOUNDRY CO.** (The), 23rd and Wood sts., Philadelphia, Pa.  
 Wm. Whittier, Jr., & Co. (Incorporated), 25th st. and Washington ave., Philadelphia, Pa.

**TURN TABLES.**  
**ANDREWS, FRANK H.**, 545 W. 33rd st., New York (vide Brakes).  
 Ayres Abraham, 502 to 518 W. 45th st., New York.  
**BRIDG (J. G. & Co.)**, Philadelphia.  
 Greig, Wm. P., 95 Liberty st., New York.  
**FULFRIE FOUNDRY**, Cleveland, O. (vide Axes).  
 Greeley, The E. S., & Co., 5 and 7 Day st., New York.  
**HATHAWAY & ROBINSON**, 14 Case Bldg., Cleveland, O.  
**HIGGINS, FORDNEY**, Cleveland, O. (The), Kansas City, Mo.  
**JOHNSTON STEEL STREET RAIL CO.** (The), Johnstown, Pa. (vide Rails, Steel).  
 Kaestner Chas., & Co., 303 S. Canal st., Chicago.  
**LEWIS & FOWLER MFG. CO.** (The), 27 to 35 Walworth st., Brooklyn, N. Y.  
**MARTIN, RUFUS**, Supply Co., Albany, N. Y. (vide Cable Yokes).  
**PUGH & RUSSELL**, Stewart Bldg., New York; Phoenix Bldg., Chicago, Ill.  
**SNAPD & BIBB**, Louisville, Ky.  
**STREET RAILWAY SUPPLY CO.**, Cleveland, Ohio.  
 Wm. Whittier, Jr., & Co. (Incorporated), 25th st. and Washington ave., Philadelphia, Pa.

**UPHOLSTERY, MATS, ETC.**  
**BEADLE, EDWARD**, 1193 Broadway, New York (vide Folding Mats).  
 Everit, W. L., New Haven, Conn.  
 Goff, D., & Sons, Pawtucket, R. I. (Mohair Brush).  
 Gould, J. H., & Gould & Co., Philadelphia (vide Gripe).  
 Hale & Kilburn Mfg. Co. (The), 48 and 50 N. 6th st., Philadelphia.  
**HARTFORD WOVEN WIRE MATRESS CO.** (The), P. O. Box 363, Hartford, Conn.  
 Lynn & Pettib, 707 Market st., Philadelphia, Pa.  
**Warren & Toller**, 211 E. 22nd st., New York (vide Folding Mats).

**VARNISHES.**  
 Babcock, John, & Co., 2 Liberty sq., Boston, Mass.  
 BRIDG (J. G. & Co.), Philadelphia.  
**BROWNELL & WIGHT CAR CO.**, 2300 Broadway, St. Louis, Mo.  
**COFFIN, DEVOE & CO.**, 176 Randolph st., Chicago, Ill.  
 Greeley, The E. S., & Co., 5 and 7 Day st., New York.  
**MARTIN, RUFUS**, & CO., 13 Park Row, New York (vide Bearings).  
 Murphy & Co., 238 McWhorter st., Newark, N. J. (Branches—327 Broadway, New York; 566 Canal st., Cleveland, O.; 262 Wabash av., Chicago; 300 S. 4th st., St. Louis, Mo.).  
 Parrott Varnish Co., Bridgeport, Conn.  
 Pomeroy & Fischer, 30 Frankfort st., New York.  
 Post & Company, Cincinnati, Ohio.  
**PUGH & RUSSELL**, Stewart Bldg., New York; Phoenix Bldg., Chicago, Ill.  
 Shipman & Bolen, Newark, N. J.  
**STREET RAILWAY SUPPLY CO.**, Cleveland, Ohio.  
 Valentine & Co., 245 Broadway, New York (vide Paints).

**VETERINARY SUPPLIES, Etc.**  
 Arnsheim, D., 52 Second av., Pittsburgh, Pa.  
**Humphrey's Homeopathic Medicine Co.**, 109 Fulton st., New York.  
**FUGH & RUSSELL**, Stewart Bldg., New York; Phoenix Bldg., Chicago, Ill.  
 ROBERTS, F. F., 1741 Broadway, New York.  
**SOMERVILLE, DR. WM., & SONS**, 127 Erie st., Buffalo, N. Y.  
 Vacuum Oil Co., Rochester, N. Y. (vide Oils).  
 Williams (Lawrence) & Co., Cleveland, Ohio.

**WELDING DIES (for Sharp Calks).**  
 Burke, P. F., 360 Dorchester av., Boston, Mass. (vide Toe Calks).

**WINDOW WASHERS (Car).**  
 Phoenix Steel Wire Broom and Brush Co., 199 E. Randolph st., Chicago, Ill.

**WIRE AND WIRE ROPES.**  
 Bullivant & Co., 72 Mark Lane, London, E.C.  
 Cable Railway Co., 329 Market st., San Francisco, Cal.  
**ROBERTS, SONS CO., JOHN A.**, 117 and 119 Liberty st., New York.

**WOOD FILLEES.**  
 CHICAGO WOOD FINISHING CO., 143 and 145 S. Chicago st., Chicago, Ill.

**WOOD SUPPLIES (for Cars).**  
 KUHLMANN CAR CO., 490 St. Clair st., Cleveland, O.

**Boston Street Railway Consolidation.**

The directors of the Metropolitan R. R. Co., of Boston, passed an important resolution, July 11, bearing upon the consolidation of all the street railways of Boston and vicinity, as follows:

"Whereas, the West End Street Railway Company has offered to exchange its cumulative preferred 8 per cent. stock for the stock of the Metropolitan Railroad Company in the proportion of one and a quarter shares of said preferred stock for each share of the stock of the Metropolitan Railroad Company.

"Resolved, that the directors of the Metropolitan Railroad Company believe it to be for the interests of its stockholders to accept said offer, and recommend them to make the exchange on the terms proposed."

The president of the expiring Metropolitan, Mr. Calvin A. Richards, makes valuable comments thereon, his judgment being matured by many years' experience. He says, *inter alia*:

"Permit me to say that in an experience of many years I have never known our board to give more careful, deliberate and thoughtful consideration to a matter than we did to this, for although we were fully aware that the control of affairs was soon to pass from our hands we felt that so far as we were able to do so, the larger number of shares still in the hands of the minority should be protected by us, even though we were only requested to recommend their exchange for the stock of another corporation. As the subject presented itself to us in the light of existing facts, the exchange seemed to be the very best thing possible for us to do, and for the following reasons:

"Our books show plainly that over 20,000 of the 40,000 shares of this company had been bought and paid for, and were now owned and held by the gentlemen composing the West End St. Ry. Company. They had bought these shares at a high price for the purpose of gaining control of voting power in our corporation. To any one at all familiar with the laws governing corporations of this kind the fact is made plain at once, and now, especially, under the great powers given them by the last Legislature, that they can do almost anything

they please, and do it legally, with the franchise and property of this company.

"Almost to our surprise they made us the proposition above referred to, which does not act in any coercive way whatever. They do not now attempt to make use of the controlling power which have cost them so much. They simply invite the minority stockholder to deposit his shares for exchange and receive therefor the preferred shares of the West End Railway Company, upon which they guarantee forever a dividend of 8 per cent., and to bring that dividend up to the standard of 10 per cent., which we have only paid for eighteen months, they give us a premium an increased number of shares amounting to 25 per cent. So that in money value we get an assured cumulative dividend of 10 per cent., i. e., cumulative means that if for any reason a dividend is ever passed for any length of time it remains as a lawful claim and must be paid. The situation, then, is precisely this: We get a guaranteed unfailing interest of 10 per cent. on the par value (\$50) of the preferred stock, which we are invited to take in exchange for our shares in the Metropolitan company. No coercion by control, but the free-will offering of those who hold the positive unassailable power to do almost anything else with us they please.

"We have been asked by many the very natural questions, What is the capital of the West End road, and what guarantee can they give that these dividends will be paid?

"As I understand it, the capital at present is simply nominal—some \$80,000; a nucleus around which will gather the entire capital of all the roads they propose to call into it. The stockholders of that company deposit all the shares they own in the Metropolitan, Cambridge and South Boston roads for exchange precisely as they ask us to do with ours. They inform me that they intend to proceed at once, after consolidation is effected, to build, under the rights that Brookline and Boston have given them, an amount of track, and equip it, which will cause an expenditure of half a million of dollars. With this addition they will then have a capital of over seven millions of dollars." Mr. Richards, as stated in this month's GAZETTE, is the general manager elect.

**P. F. BURKE,**

Successor to C. F. DEWICK & CO.,

Manufacturer of

**Patent Steel Shoe Calks,**

BLUNT AND SHARP.

WELDING DIES FOR SHARP, AND HORSE SHOERS' FOOT VISES.

**360 Dorchester Avenue, BOSTON, MASS.**

For Sale by Iron, Steel and Heavy Hardware Dealers. Send for Circulars.

J. MURRAY MITCHELL,  
President.

KARRICK RIGGS,  
Treasurer.

HENRY S. ISELIN,  
Secretary and Manager.

J. MURRAY MITCHELL,  
(DICKERSON & DICKERSON) Counsel.

# SAFETY ELECTRIC RAILWAY AND POWER COMPANY.

(DAFT SYSTEM.)

## ELECTRIC RAILWAY MOTORS

Electric Light and Power Machines. Electrical Conductors.

We are prepared to build and equip Railways with our Electric System and supply

**LIGHT!**  
—AND—  
**POWER**

Machines at the shortest notice.

Complete installation of Central Stations for the distribution of Power a specialty.

Cars equipped with the

**DAFT Electric System**

can be lighted with the same current that operates the Motor.



DAFT ELECTRIC RAILWAY AT ORANGE, N. J.

Estimates,  
Catalogues,  
and any information furnished on application.

We guarantee the successful operation of our system.

**Heaviest Grades**  
NO OBSTACLE.

On receipt of full particulars, we will send you exact estimate of the cost of equipment and operation under

**Our System.**

We have the only absolutely self-regulating Motor in the World.

From the *Los Angeles Illustrated Herald*, March, 1887.

The Los Angeles Electric Railway is a corporation organized for the purpose of constructing and operating electric railways in the City of Los Angeles.

The Los Angeles Electric Road is undoubtedly the most successful electric road in the United States. Col. Howland secured the benefit of the working of other roads and adopted the best improvements that experience could suggest. The speed of the road is usually from 10 to 12 miles per hour, as fast as is deemed safe for the streets of the city. The apparatus is under the most perfect control, and can be stopped on the instant, and if necessary, be reversed in motion. Cars have been run at times at a speed of 20 miles per hour.

The road has been running nearly two months and not failed a single day. It has carried in a single afternoon on three cars, a distance of three miles, fifteen hundred passengers.

The Electric Railway Company has now in operation three miles of electric railway on Pico Street, and are building two miles more to reach the Plaza.

The cost of construction is about one-third of a cable road. The cost of maintenance about 60 per cent of a cable road. Its speed can be made greater.

The cost of running an electric road can be estimated at one-half of a horse road, and its capacity four fold greater.

This road is one of the many enterprises that Los Angeles contributes to astonish the visitor, and is daily visited by hundreds of our sojourners.

From the *Los Angeles Times*, March 5, 1887.

### THE ELECTRIC ROAD. A FLATTERING OPINION.

H. C. Moore, Prosecuting Attorney of San Jose, and prominently connected with street railroads in that city and San Francisco, has been here for several days on business—with which he has contrived to mingle considerable pleasure. Mr. Moore is one of the owners of the horse-car system in San Jose—the system embracing about five miles of track, and an investment of about a quarter of a million dollars. The franchise of the company runs out in a year, and the company has applied for a renewal with the privilege of turning the system into an electric road.

To find out the exact facts in the case, Mr. Moore came down here to see for himself. He has examined the Pico Street electric road thoroughly, ridden over it, and is surprised and delighted with it.

After a couple of days' chase, a *Times* representative caught Mr. Moore yesterday, and had a short conversation with him on the subject of his visit. Mr. Moore said: "We heard about your electrical road, I came down and see it for myself, and am surprised at the success and smoothness of your road. I have ridden over it, and must say it is the smoothest riding I ever rode on. You actually cannot tell, unless you watch some stationary object, just when you start and when you stop. It

Address all communications to

**SAFETY ELECTRIC RAILWAY AND POWER CO.**  
Office, 41 & 43 WALL ST., NEW YORK. Factory, GREENVILLE, N. J.

is a wonderful thing. Now, the Market Street road in San Francisco is the finest cable road on earth. It cost hundreds of thousands of dollars a mile. Your electric road is built very cheaply on an ungraded street whose soil is like ashes when dry, and like mortar when wet; and still, for comfort and smoothness, it is perfection. It is as much ahead of the Market Street cable road as the Market Street road is ahead of a horse railroad. I am more than satisfied with its workings.

From the *Electrical World*, March 25, 1887.

The Daft road, at Los Angeles, is working admirably. The road carried 14,932 passengers during February, and is developing a large and rapidly growing business. It is proposed to adopt the system for a road at San Jose, using a simple form of conduit system. Mr. H. C. Moore, one of the large owners of the San Jose road, which has hitherto been run by horses, inspected the Los Angeles road recently and pronounced a strongly favorable opinion on its merits.

BALTIMORE, Sept. 25, 1886.

SAFETY ELECTRIC RAILWAY AND POWER CO., NEW YORK.

Gentlemen:—In answer to yours of the 23d inst., making inquiries in relation to the Baltimore & Hampden Electric Railroad, I have to say that its success by the change from horse and mule power to electric power under the Daft System has exceeded my highest expectations. It has largely increased the travel on the route, and at a less operating expense than horse power. The road has been running more than a year by electricity with as much regularity as any road in the country. I find less difficulty in getting men to run the motors properly than I do to get men to run the ordinary horse car property. The road is now being run by persons who before their employment here were unfamiliar with electrical affairs. \* \* \*

T. C. ROBBINS, GENERAL MANAGER.

REPORT OF T. C. ROBBINS, Esq., Manager of Baltimore Union Passenger R. R. Company, showing results of running the Baltimore & Hampden Road by DAFT ELECTRIC MOTORS.

In the year ending September 1st, 1885, with horses, at a speed of 4.033 miles per hour:	In the year ending September 1st, 1886, with Electricity, at a speed of 8 miles per hour:
Passengers carried were..... 227,155	Passengers carried were..... 311,141
Gross Earnings were..... \$11,357.75	Gross Earnings were..... \$15,557.05
Cost of Motive Power was..... 7,117.50	Cost of Motive Power was..... 4,830.00
Cost of Motive Power per Passenger per mile was..... .0156	Cost of Motive Power per Passenger per mile was..... .007

- I. An Increase in Traffic of..... 37 per cent nearly
- II. A Reduction in Cost of Motive Power in Gross of..... 33 per cent.
- III. A Reduction in Cost of Motive Power in Gross per Passenger per mile of..... 55 per cent.



# DIRECTORY SUPPLEMENT.

# The Street Railway Gazette.

VOL. 11.

CHICAGO.

SEPTEMBER, 1887.

NEW YORK.

No. 9.

## THE RELIABLE SAND BOX.



OVER 500 NOW IN USE.

*AUTOMATIC, SIMPLE and EFFECTIVE.*

IS GUARANTEED TO RUN

Sand, Salt or Common Gravel.

IS INCREASING IN PUBLIC FAVOR DAILY.

SEND FOR ILLUSTRATED CIRCULAR "B."

W. T. BUTLER, GEN'L MNGR., 19 TREMONT ROW, BOSTON, MASS.

## THE BRYDEN FORGED HORSE-SHOE WORKS, LIMITED.

CATASAUQUA, PENN.

MANUFACTURERS OF

## The Bryden Forged Solid Calk HORSE AND MULE SHOE.

ADOPTED BY THE FOLLOWING STREET RAILWAYS:

*The Third Avenue R. R. Co., Eighth Avenue R. R. Co., Broadway & Seventh Avenue R. R. Co., of New York City; Bushwick R. R. Co., Brooklyn City and Newton R. R. Co., of Brooklyn; Philadelphia Traction Co., Citizen's Passenger R. R. Co., Second & Third Street R. R. Co., of Philadelphia; Metropolitan R. R. Co. of Washington, D. C.; North Chicago R. R. Co., Chicago City R. R. Co., West Division R. R. Co., of Chicago, Ill.; New Orleans City & Lake R.R., Co., of New Orleans, La., etc. etc.*

**J. B. WHITE, MANAGER SALES DEPARTMENT,**

234 Lake Street, CHICAGO, ILLS.

# KUHLMANN CAR CO.

BUILDER OF

# STREET RAILWAY CARS

OF EVERY DESCRIPTION.

ALL KINDS OF WOOD WORK FOR INTERIORS A SPECIALTY.

Street Railway Companies building their own Cars will do well to correspond with us.

Office: 490 St. Clair Street, CLEVELAND, O.

## CLEVELAND FOUNDRY,

MANUFACTURERS OF

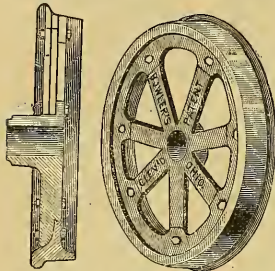

### Car and Locomotive Wheels, *Either Chilled or Steel Tired, with or without axles.*

Street Railway Wheels, Turnouts and Turntables, Patent Chilled Face R. R. Frogs, Engine and Heavy Castings a Specialty.

### GRADED STABLE CUTTERS WITH STRAIGHT OR CURVED COVER.

Descent 1/2 inch per foot. Pieces 5 feet lengths. Short pieces furnished to suit any length. Spouts to connect with sewer.

They control and make N. P. Bowler's Patent Street Railway Wheel. The tire of this wheel is cast separately from the hub and spokes; the latter is made of soft strong iron, and is perfectly free from strain—therefore can be made much lighter and more durable. The tires and the spokes or center of the wheel are made perfectly interchangeable so that when the tire or rim is worn out another can be put in its place by any employee with no other tool than a common wrench.

**BOWLER & CO., 10 to 24 Winter St., CLEVELAND, OHIO.**

# Use IRON CLAD PAINT

FOR YOUR CARS, BARNs AND BUILDINGS.

OFFICE OF EAST CLEVELAND RAILWAY CO.  
 IRON CLAD PAINT CO.:  
 Gentlemen.—This Company, for the last 17 years, has extensively used your "Iron Clad Paint" upon its buildings, roofs and cars. For durability, protection against fire, and cheapness, there is no paint that will compare with it. It is equally as good for use as for coarse work; it polishes beautifully. The paint upon the bodies of our cars which was put on ten years ago, is as firm and good as when first put on, while the other kinds of paint put on at the same time, has been renewed twice; nothing has been done to the Iron Clad except new coats of varnish.

EDWIN DUTY, Superintendent.  
 WM. KRUEGER, Painter.

OFFICE OF THE MASTER CAR BUILDER,  
 Toledo, Wabash & Western R'y.  
 Toledo, O., Feb. 18, 1875.

IRON CLAD PAINT Co., Cleveland, O.:  
 Dear Sir:—In reply to your letter of the 9th inst., as to the use of the "Iron Clad Paint" by this Company, would say: That we have been using it for the past year on our passenger and baggage cars, and are very much pleased with it. We can cheerfully recommend it for its body, durability and cheapness. Accompanying this you will find a sample of the color we use on our coaches, which is obtained by grinding together 20 pounds of Rosin and one pound Lamphack.

Respectfully,  
 U. H. KOHLER, M. C. B.

THE  
 PUREST.  
 THE MOST  
 FIRE-PROOF.  
 THE MOST  
 DURABLE  
 PAINT  
 IN THE  
 WORLD.



Trade Mark Patented—Paint Patented.

THE  
 Cheapest.  
 THE MOST  
 Economical.  
 THE MOST  
 Water-Proof  
 PAINT  
 IN THE  
 WORLD.

Refer to East Cleveland Street Railway Company, who have used it for nearly Twenty Years.

## IRON CLAD PAINT COMPANY, - CLEVELAND, OHIO.

A Discount of 5 per cent to any one mentioning this Advertisement.



# OFFICIAL DIRECTORY

## OF THE STREET RAILWAYS (OR TRAMWAYS)

The United States, Canada, Mexico, South America; Great Britain, Ireland; Germany, France, Austria, Switzerland, Belgium, Holland; India, Australia, &c.

Compiled, from original data furnished by the companies, (and corrected monthly,) by WM. HUGHES, Editor of THE STREET RAILWAY GAZETTE, to whom all additions and corrections should be addressed.

### American Street Railway Association:

By THOMAS W. ACKLEY, 621 N. 35th St., Philadelphia, Pa., U. S. A.  
Sec'y & Tr Wm. J. RICHARDSON, Atlantic Ave. RR. Co., Brooklyn, N. Y., U. S. A.

### The Tramways Institute of Great Britain and Ireland:

By HENRY HUTCHISON, Carlisle, Scotland.  
Sec'y J. H. DUNNAN, F. C. A., 11 Coleman St., E. C., London, England.

### The Street Railway Association of the State of New York:

By G. H. SCHRIENER, Central Park, N. & E. River RR. Co., New York.  
Sec'y & Tr Wm. J. RICHARDSON, Atlantic Ave. RR. Co., Brooklyn, N. Y.

### The Permanent International Tramways Union

(Union Internationale Permanente de Tramways):  
By H. G. MICHELLETT, Les Tramways Bruxelles, Brussels, Belgium.  
Sec'y F. NONNEBERG, 49 rue du Vauvour, Brussels, Belgium.

### Ohio (U. S. A.) State Tramway Association:

By D. W. STROUD, Citizens' St. RR. Co., Springfield, Ohio.  
Sec'y H. A. EVERETT, 1154 Euclid Ave., Cleveland, Ohio.

### EXPLANATIONS:

When the name of a city is incorporated in the name of a company, it is abbreviated; thus Birmingham = Bm. Also Street = St., Railway = Ry., Tramway = Tr., Railroad = Rtl., Passenger = Pass., Metropolitan = Met. President is abbreviated Pr.; Vice-President, VP; Chairman, Chm; Director, Dir; General Manager, GM; Superintendent, Spt; Secretary, Sec; Treasurer, Tr; Engineer, Engr.

The figures (in parentheses) after name of city show population according to last census, that for the United States having been taken in 1880, and those for Canada, Great Britain and Ireland, &c., in 1881. For more recent figures, dates are given. The following prefixes denote: \* members of the American Street Railway Association; † members of the Tramway Institute (Great Britain and Ireland); ‡ members of the Permanent International Tramways Union (Europe); § members of the Street Railway Association of the State of New York; and ¶ members of the Ohio State Tramway Association.

The gauges, throughout this Directory, should be understood to be the ordinary 4 feet 8½ inches—except when otherwise specified; g means gauge; lb, pounds weight of rail to yard; T represents T rail, and ob, centre-bearing; *lbs* (*italics*) signify that the rails are steel; m stands for miles length of single track; c, cars; cgr, grip cars; h, horses; mu, mules; m, motor or motors; stm, steam. Address is given in full (street and number) after every company's name who have stated the same; and in all cases the name of company and that of city or town, together with the state, (in the United States), is sufficient postal address.

### UNITED STATES.

#### ALABAMA.

**Aniston** (942). The Aniston St. Ry. Co.—Pr John W. Noble, Sec Wm. A. Davis, Eng'rs Moorhead and Hines; 3 m, 20 lb T.  
**Auntion**, Oxford & Oxanna St. Ry. Co. (office at Oxanna).—Pr T. C. Hill, Sec & Tr W. S. Larned, Spt J. B. Allen; 3.25 m, 20 lb T; 4 c, 5 h, 10 mu.  
**Birmingham** (3,986). Imp. Union St. Ry. Co.—Pr J. A. Van Hoose, Sec B. C. Scott, Spt F. S. H. P. 1 lb T; 35 c, 12 20 lb mu.  
**Bm. & Jones Valley St. RR. Co.**—Helli & Knox, contractors; 12 m, 45 lbs.  
**East Lake Land Co.**—Pr Roubt. Jamison, Sec & Tr S. M. Hanly, Eng'rs F. W. Beall; 7 m, 40 lbs T; 4 c, 3 stm tr, operated by the Bm. Union St. Ry. Co.  
**Highland Avenue and Belt RR. Co.**—Pr H. M. Caldwell, GM & Sec V. J. Miller, Spt J. M. Lewis, Eng'rs H. Schoel; 6.5 m, 36 and 54 lb T; 1 c, 5 stm tr.  
**North Em. St. RR. Co.**—Pr J. W. Johnston.  
**Western Valley St. RR. Co.**—Pr J. C. Westbrook, Sec W. H. Naff; 2.5 m.  
**Calera** (234). The South Cal. St. Ry. Co.—2 m.  
**Decatur** (1,063). Decatur Land Imp. and Furnace Co. (St. Ry.)—1.5 m.  
**Euftala** (3,836). City of Eu. St. Ry. Co.—Pr E. B. Young, Sec G. McCormick; 4 m, 20 lb T; 4 c, 12 h.  
**Flomberg** (1,389). Mo. St. RR. Co.—Pr W. B. Wood.  
**Huntsville** (4,977). The North Ala. Imp. Co.—1 m.  
**Mobile** (29,132). Mobile St. Ry. Co.—Pr Wm. M. Duncan, Sec. Tr & GM R. K. Warren; 24 m & 2½ c, 30 to 47 lb T; 64 c, 9 h, 220 mu.  
**Dauphin & Lafayette Ry. Co.** (28 St. Francis St.)—Pr D. P. Bestor, VP & Sec G. F. Overall, Spt J. B. Connor; 2 m, 5.25 c, 40 lb T; 10 c, 6 lb, 16 mu.  
**Mo. & Spring Hill RR. Co.**—Pr E. K. Warren, Sec & Spt C. F. Suddow; 6.5 m, 5.25 c, 35 to 60 lb; 10 c, 2 h, 41 mu 3 stm tr.  
**Montgomery** (16,713). Capital City Electric St. Ry. Co.—Pr E. B. Joseph, GM J. A. Gaboury, Sec E. Taylor; 12 m, 4 c, 32 lbs T; 15 electric mu (VanDeypele's).  
**Selma** (7,529). Selma St. RR. Co.—Pr H. L. McKee, Sec J. F. Brown; 5 m, 4.9 c, 20 lb T; 7 c, 3 stm tr.  
**Selma Land Imp. & Furnace Co.** (Electric St. Ry.)—Pr E. M. Nelson.  
**Tusculum** (2,415). Tusc. & Castle Hill St. Ry. Co.—GM W. Hill; 4.5 m.  
**Tuscumbia** (1,369). Shiloh & Tusc. St. RR. Co.—Pr F. D. McMillan, Sec E. B. Almon; 6 c, 2, 1 stm tr.

#### ARKANSAS.

**Argonia** (500). Arg. & Big Rock St. Ry. Co.—Pr S. Adams.  
**Fort Smith** (3,097). Ft. S. & S. Springs RR. Co.—Pr W. McLoud, Sec Geo. T. Sparks, Spt W. Ewers; 2 m, 3-6 c, 28 lb; 5 c, 16 mu.  
**Helena** (3,652). Helena St. Ry. Co.—Pr Wm. G. Quarles, Sec D. T. Hargraves.  
**Hot Springs** (24,000). Hot Springs RR. Co.—Pr S. W. Perry, Sec C. E. Maurice; Spt J. L. Butterfield; 3 m, 4 c, 25 lb tr; 11 c, 68 h.  
**Little Rock** (13,138). Little Rock St. Ry. Co.—Pr Jas. R. Miller, Sec A. N. Johnson, Spt J. A. Garrett; 1 m, 4-10 c, 35 and 42 lb; 32 c, 36 h, 160 mu.  
**Citizens St. Ry. Co.** Owned and operated by Little Rock St. Ry. Co.; 5 m.  
**Pine Bluff** (3,803). The Citizens' St. Ry. Co.—Pr John M. Taylor, Sec John O'Connell, Spt H. P. Bradford; 2.25 m, 35 lbs T; 6 c, 23 mu.  
**The "Wiley Jones" St. Ry. Co.**  
**Searcy** (540). Searcy & West Point RR. Co.—Pr & Spt A. W. Yarnell, Sec Jasper Hickey; 4 m, 3 c, 25 and 6 (fr.) 10 mu.  
**Texarkana** (3,223). Tex. St. Ry. Co.—Pr C. E. Mitchell, Sec Thos. Orr, Spt R. M. Foreman, Eng'rs L. Christopher, C. J. Big; 16, 20 and 24 lb T; 4 c, 8 h, 6 mu. The State Line RR. Co.—Pr E. A. Warner.

#### CALIFORNIA.

**Anaheim** (833). Anaheim St. Ry. Co.  
**East Oakland** ( ). Oakland, Brooklyn & Fruit Vale RR. Co.—Pr Hiram Tubbs, Sec W. C. Mason, Spt Jas. Dixon; 3.5 m, 3-6 c, 35 lb; 4 c, 25 h.  
**Los Angeles** (11,183). City & Central St. Ry. Co.—Pr J. W. Hellman, Sec R. D. Widdow, Spt Wm. Hawks; 22.5 m, 3-6 and 4-8 c; 37 c, 232 h.

**Central and Boyle Heights RR. Co.**—Pr E. F. Spence, Sec F. Harkness, Spt W. Hawks; 7 m, 3-6 c, 16 lb; 26 c, 111 h.  
**Los Angeles & Aliso Ave. St. RR. Co.**  
**Los Angeles Cable Ry. Co.** (132 N. Main St.)—Pr J. P. Crank, GM Chas. Forman, Sec F. D. P. Widner; 20 m, pt 3-6 c, 20 lb; 41 c, 273 h.  
**Los Angeles Electric Railway Co.** (Bart. Station).—Pr G. H. Bonebrake, GM and Sec. H. Howland.  
**Maln St. & Agricultural Park RR. Co.** (10 Commercial St.)—Pr W. J. Brodrick, Sec A. C. Taylor, Spt E. M. Lorricker; 10 m, 3-6 c, 16 lbs T; 22 c, 80 h.  
**Second St. Cable RR. Co.** (Cor. 2d and Figueroa Sts.)—Pr Jas. McLaughlin, Sec H. W. Davis; 3.70 m, 3-6 c, 16 lb T; 6 c, 6 gm, 1 statn mu. cable engine 60 hp.  
**Tenille St. Cable Ry. Co.**—Pr F. Healdy, Sec F. W. Wood, Spt J. Fowler; 1.63 m, 3-6 c, 16 lb T; 6 c; engine 80 hp.  
**The American Rapid Transit Co.** Electric railway. (Enos System.)

#### West End.

**Marysville** (4,321). City Pass. RR. Co.  
**Oakland** (34,555). Alameda, Oakland & Piedmont RR. Broadway & Piedmont St. RR. Co.—Pr Walter B. Carr, Sec Mont. Howl; 3 m, 5 g, 30 lb; 18 c, 45 h.  
**Brooklyn & Fruit Vale RR.**—Pr E. C. Sessions, Sec W. W. Hill; 2.25 m; 5c, 18 h.  
**Fourth St. RR. Co.**—Pr & Spt Walter Blair, Sec J. W. Britton; 3 m, 5 g; 25 and 33 lb; 10 c, 51 h.  
**Oakland RR. Co.**—Pr J. G. Blair, Sec C. L. Neal, Spt G. Y. Loring; 3 m, 3 g, 60 lb; 9 c, 35 h.  
**Oakland, Brooklyn & Fruit Vale R.R. Co.**—Pr H. Tubbs, Sec W. C. Mason, Spt G. H. Mason; 2.45 m, 5 g, 35 lb; 4c, 25 h.  
**Oakland Cable Ry. Co.** (Office same as those of Oak. RR. Co.); 5 m, 3 g, 40 lb; 10c Pasadena (391). City Ry. Co. (P. O. Box 534).—Pr C. W. Buehnan, Spt A. J. Painter, Sec M. D. Painter; 3 m, 16, 20 and 30 lb; 4 c, 61, 10 mu.  
**Colorado St. RR. Co.** (Box 193).—Pr & Spt G. E. Meharry, Sec C. W. Sawtell, Eng'rs J. M. Willard; 3 m, 3-6 c, 16 lbs T; 3 c, 6 h.  
**Highland RR. Co.**—Pr T. A. Swartwoot, Sec J. E. Young, Spt C. C. Thompson; 5 m, 16 and 30 lb; 6 c, 24 h.  
**Park Place RR. Co.**  
**Pas. St. RR. Co.**—Pr Stephen Townsend, Sec P. G. Wooster, Spt & Eng'r Willhel Pumpson; 3.25 m, 3-6 c, 16 lbs T; 3 c, 15 h.  
**Sacramento** (21,420). City Ry. Co.—Prop R. S. Carey, Spt Geo. W. Carey; 23 c.  
**S. Highland RR. Co.**—Pr G. A. Swartwoot, Sec J. E. Young, Spt C. C. Thompson; 5 m, 16 and 30 lb; 6 c, 24 h.  
**San Diego** (2,637). S. D. St. Car. Co.—Pr H. L. Story, Sec H. W. Mallett, Spt C. E. Williams; 5 m, 16 and 20 lb T; 12 c.  
**S. D. & National City Motor Line**  
**The Coronado Beach Co.**—Pr H. L. Story, Sec & Tr O. S. Hubbell; 4.5 m, 20 lb T; 5 m tr.

**San Francisco** (233,959). California Street Cable RR. Co. (1435 California St.)—Pr Chas. Mayne, Sec T. W. Hinchman, Spt J. W. Harris, Eng'rs A. D. McLean; 1 m, 3-6 c, 34 lb T; 27 c, 25 c, 4 h; engine 800 hp.  
**Central RR. Co.** (44 Turk St.)—Pr Chas. F. Crocker, Sec J. L. Willcutt, Spt John F. Clark, Eng'rs A. Reilly; 12 m, 5 g, 45 lb; 60 c, 300 h.  
\*City RR. Co. (The).—Pr Leland Stanford, Sec J. L. Willcutt (4th and Townsend Sts.), Spt H. L. Gude (1804 Mission St.); 11 m, 5g, 45 lb; 72 c (54 one-h, 18 two-h), 280 h.  
**Clay & Hill RR. Co.** (s.w. cor. Clay and Leavenworth Sts.)—Pr & Spt Joseph Britton, Sec Chas. P. Campbell, 1 m, 3-6, 30 lb; 11 c, 12 c; engines 120 hp.  
**Geary St., Park & Ocean RR. Co.** (4th and Townsend Sts.)—Pr Chas. F. Crocker, 4 m, 16 and 30 lb; 18 c, 24 h.  
**Market St. Cable Ry. Co.**—Pr Leland Stanford, Sec J. L. Willcutt; Eng'rs C. P. Stoughton & J. H. Willcutt; 4 m, 5 g, 45 lb; 60 c, 300 h.  
**North Beach and Mission RR. Co.** (4th and Louisiana Sts.)—Pr Albert Meyer, Sec H. W. Hattner, Spt M. S. Morrow; 16 m, 5 g, 45 lb; 64 c, 420 h.  
**Ocean Beach Ry.**—2 m; operated by Mart. St. Cable Ry. Co.  
**Omnibus RR. & Cable Co.** (727 Howard St.)—Pr Gustav Sutor, Sec G. Ruepp, Spt J. M. Moran; 12 m, 5 g, 40 and 42 lb; 60 c, 400 h (charging to cable).  
**Park & Ocean RR. Co.**—Pr Chas. F. Crocker, Sec J. L. Willcutt; 4.62 m, 35 and 30 lb; 22 c (16 pass, 6 flat and section) 7 stm tr.  
**Porter & Bay View RR. Co.**—Pr Leland Stanford, Sec J. L. Willcutt; 1.61 m, 5 g, 35 lb; 10 c, 42 h.  
**Powell St. Ry. Co.** (Rm. 32 Merchants' Exchange)—Pr W. J. Adams, Sec G. H. Wagoner, Eng'rs J. C. Holmes; 11 m, 3-6 c, 38 to 40 lb; 32 c and 8 mu tr (combined); cable engines 800 hp.  
**Presidio & Ferries Ry. Co.**—10 m; 35 c, 22 h, 4 stm tr.  
**Sutter St. RR. Co.** (29 S. 2d St.)—Pr M. S. Morrow, Sec A. K. Stevens, Spt Jas. McCord; Eng'rs W. J. Slattery; 12 m, 5 g, 45 lb; 22 c, 34 c, 180 h; cable engines 500 hp.  
**Telegraph Hill RR. Co.**—Pr Gustav Sutor, Sec & Spt Chas. J. Werner; 1,560 ft, 45 lb; 2 c. Operations suspended until completion of Powell St. Cable Ry.  
**San Jose** (12,567). San Jose & Santa Clara RR. Co. (20 W. Santa Clara St.)—Pr J. H. Leland Stanford, Sec J. Eugene Rosenthal, Spt Wm. Fitts; 3 m, 4-8½ & 3 g, 20 and 45 lb T; 19 c (18 one-h, 1 two-h), 75 h.  
**First St. RR. & Willow Glen RR.**—Sole owner Jacob Rich, Sec E. M. Rosenthal; 4½ m, 3 g, 30 lb; 10 c, 30 h.  
**First St. & San Pedro St. Depot RR. Co.**  
**North Side Horse RR. Co.**—Pr & GM Jacob Rich, Sec E. M. Rosenthal; 2½ m, 5 g, 16 lb; 3 c, 10 h.  
**Willow Glen RR.**—Sole owner Jacob Rich, Sec E. M. Rosenthal; 7.5 m, 3 g, 20 lb; 5 c, 30 h.  
**San Luis Obispo** (2,243). S. L. O. St. Ry. Co.—Pr Edwin Goodall.  
**Santa Ana** (711). Santa Ana, Orange & Tustin St. RR. Co.—Pr & Spt M. J. Bund, Sec D. M. Tomblin; 4.33 m, 3-6 c, 16 lbs T; 3 c, 10 h, 2 mu.

JOHN J. BRODERICK, Prest.

JOS. D. BASCOM, Sec. & Treas.

**B**roderick & Bascom  
Rope Co.

Manufacturers



**ROPE**

**Cable Ropes**

FOR

**STREET RAILROADS.**

**WIRE**

St. Louis, Mo.

# The Horace A. Keefer Co.,

KANSAS CITY, MO.

## Street, Cable, Motor & Steam Railway

EQUIPMENT AND TRACK MATERIAL A SPECIALTY.

### PRICE'S IMPROVED FARE BOX.

THE BEST IN THE MARKET.

The ringing of a gong for each fare, checks the passenger as well as the driver, and hence conductor's bell punch is unnecessary.

It is positively the best fare collector in the *World*.

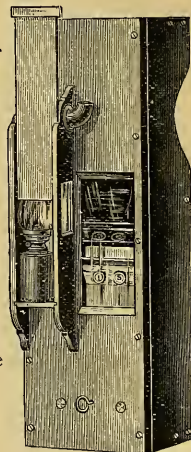
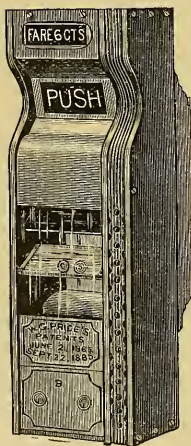

**Corliss Engines, Safety Boilers, Feed-Water Heaters, Pumps,**

**WINDING GEAR AND CABLE OUTFITS COMPLETE**

Can always secure our customers good bargains in second-hand Supplies and Equipments.



**Santa Barbara** (3,400). S. B. St. Ry. Co.—*Pr* A. W. McPhail; 1.5 m, 3-6 k; 3 c, 10 m.  
**Santa Anna** (3,616). E. L. St. Ry. Co.—*Pr* A. B. Ware.  
**Vallejo** (5,087). Vallejo St. Ry. Co.

**Denver** (35,420). "Denver City Ry. Co.—*Pr* H. Holt (10 Wall Mt., New York), *GM* G. E. Handolph, *Sec* G. D. Lullifer; 25 m, 3-6 g, 21 lb. T; 70 c, 400 h.  
 D. Tramway Co.—*Pr* Rodney Curtis, *Sec* Wm. G. Evans, *Spt* Jas. C. Curtis; 5.5 m, 3-6 g, 16 lb. T, 10 c, 200 h. North electric system; engines 125 hp.  
 The Colfax Ave. RR. Co.—*Pr* H. B. Chamberlain.  
**Pueblo** (3,217). P. St. Ry. Co.—*Pr* J. B. Osman, *Sec* and *Spt* J. T. Clark; 5 m, 3 g, 22 lb. T, 3 c, 25 h.  
**Silver Cliff** (9,040). N. H. St. Ry. Co.  
**South Platte** (—). Pueblo RR. Co.  
**Portland** (3,224). Tr. St. Ry. Co.—*Pr* Sol. H. Jaffe, *Sec* R. L. Wooton, *Spt* H. E. Pearson; 1.5 m, 3-2 g, 14 lb; 2 c, 8 m.

CONNECTICUT.

**Ansonia** (3,855). Birmingham & Ansonia Ry. Co.—3.5 m.  
**Berry** (Horse). West. H. & W. St. Ry. Co.—*Pr* W. H. Clark, *Spt* Jas. D. Kennedy; 3.5 m, 45 lb, 11 c (4 pass, and 7 ft.), 4 electric m (VanDeyk's); one 50 hp and 15 lbs hp.  
**Bridgport** (27,653). Bridgeport Horse RR. Co. (323 E. Washington Ave.)—*Pr* Albert James, *Sec* F. Ward, *Spt* F. Lashier; 7.5 m, 42 lb. ch; 19 c, 100 h. B. & W. Stratford H. RR. Co.—*Pr* F. F. Hollister, *GM* H. N. Hearnsley, *Sec* H. B. Drew; 2.5 m, 42 lb; 10 c, 42 h.  
**Danbury** (11,667). Dan. St. Ry. Co.—4 m.  
**Hartford** (42,015). "Hartford & Western Horse Ry. Co.—*Pr* E. S. Goodrich, *Sec* Paul. H. Howe; 1.2 m, 45 lb; 53 c, 271 h.  
**Meriden** (15,540). Horse RR. Co.—*Pr* Geo. L. Curtis, *Sec* & *Tr* C. L. Bockwell, *Spt* Dan. Barker; 5 m, 4-g, 35 lb. T; 15 c, 100 h, 10 m.  
**Middletown** (27,653). Middletown Horse RR. Co.—*Pr* John M. Douglas, *Sec* J. K. Guy, *Spt* E. M. Rice; 4 c, 24 h, 2 m.  
**New Britain** (City Ry. Co. (Trolley System).  
**New Britain** (City Ry. Co. (Tramway Co. (280 Broadway, New York))—*Pr* Alton Gray, *Sec* Jas. A. Flynn; 4 m, 35 lbs; 6 c.  
**New Haven** (62,892). Fair Haven & Westville Horse RR. Co.—*Pr* Hoadley B. Ives, *Sec* L. Child, *Spt* Wm. Graham; 10, 50 lb; 30 c, 225 h.  
**New Haven & Guilford** Horse RR. Co.—*Pr* Cornelius Pierpont, *Spt* T. R. Hull; 2.5 m.  
**State Street Horse RR. Co.** (16 Exchange Bldg.)—*Pr* C. A. Warren, *Sec* J. E. Emery, *Spt* Geo. Wells; 2.25 m, 4-g, 43 lbs ch; 5 c, 40 h.  
**Whitney Ave. Horse RR. Co.**—*Pr* G. H. Watrous, *Sec* G. D. Watrous, *Lessee* J. A. Davis (355 Orange St.); 2.25 m, 4-g, 35 lb. ch.  
**New London** (10,529). New London Horse Ry. Co.—*Pr* John Tobbetts.  
**Norwalk** (5,308). Norwalk Horse RR. Co.—*Pr* Jas. W. Hyatt, *Sec* Edwin G. Hoyt; 1.75 m, 4-10 g, 42 lb; 7 c, 20 h.  
**Norwalk** (15,123). Norwalk Horse RR. Co.  
**Stamford** (2,540). Stamford Horse RR. Co.—*Pr* F. M. Delano (45 Broadway, New York), *Sec* Robt. G. Kestler, *Spt* Wm. H. Hay; 5.33 m, 33 lbs; 10 c, 30 h.  
**Waterbury** (17,806). Wat. Horse RR. Co.—*Pr* D. S. Plimie, *Sec* G. R. Baldwin, *Spt* E. A. Bradley, *Spt* Wm. H. Hay; 100 ft.  
**West Haven** (1,975). "New Haven & West Haven Horse RR. Co.—*Pr* Geo. R. Kelley, *Sec* Saml. L. Smith, *Spt* W. W. Ward; 7 m, 50 to 60 lb. T; 34 c, 115 h.  
**Westport** (1,900). Westport Horse RR. Co.—*Pr* A. H. Harbord, *Sec* H. L. Woodworth, *Spt* E. S. Downey; 1.75 m, 40 lb; 4 c, 6 g, 6 h.  
**Winefield** (2,743). Win. St. Ry. Co.—*Pr* Geo. S. Rowa.

DAKOTA.

**Huron** (184). Hn. City Ry. Co.—*Pr* Spt Wm. T. Love, *Sec* A. W. Wilmarth; 2.75 m, 16 lb T; 4 c, (two 14 and two 16 T) 4 h, 1 m.  
**Pierre** (—). Pierre St. Ry. Co.—3 m.  
**Rapid City** (292). Rap. City St. RR. Co.—*Pr* Fred T. Evans, *Sec* A. Willse, *Spt* E. H. Chapman; 2 m, 4 g, 25 lbs; 2 c, 4 h.  
**Siodah** (—). Spt. Pull. St. Ry. Co.—*Pr* G. F. Pettigrew; 2 m.  
**Watertown** (735). Wat. St. RR. Co.—*Pr* Chas. Jesslyn.  
**Yankton** (3,431). Yank. St. Ry. Co.—3 m.

DELAWARE.

**Wilmington** (42,478). Front and Rear Ry. Co. (505 Washington St.)—*Pr* Geo. W. Bush, *Sec* & *Spt* Saml. A. Price; 1.33 m, 5-2 g; 7 c, 19 m.  
 \*Wilmington City Ry. Co.—*Pr* Wm. Chubb, *Sec* John F. Miller (500 W. 11th St.), *Spt* Wm. H. Barrett; 3 m, 2-g, 45 lb; 20 c, 64 h, 15 m.

DISTRICT OF COLUMBIA.

**Anacostia** (—). An. & Potomac River Ry. Co.—*Pr* & *Spt* H. A. Griswold, *Sec* & *Spt* F. L. Pletcher; 1 m, 4-g, 37 lb; 12 c, 30 h.  
**Georgetown** (12,000). Georgetown and Annapolis Ry.  
**Washington** (147,293). Capitol, North O Street and South W. St. RR. Co.—*Pr* Chas. White, *Sec* & *Tr* W. E. Broughton, *Spt* Andrew Glass; 13.5 m, 35 lb; 48 c, 185 h, 1 m. Columbia RR. Co.—*Pr* Geo. H. Willard, *Sec* Wm. H. Claggett, *Spt* Albert Claggett; 2.87 m; 25 c, 73 h.  
 \*Metropolitan RR. Co. (241 F St., N. W.)—*Pr* Geo. W. Pearson, *Sec* & *Tr* Wm. J. Wilson, *Spt* James H. Hays; 48 lb ch; 13 c, 150 h.  
 \*Washington & Georgetown RR. Co.—*Pr* Henry Hart, *Sec* C. M. Koonce, *Spt* C. C. Sailer; 2 m, 42 lb ch; 151 c, 800 h.

FLORIDA.

**Gainesville** (613). Gains. St. Ry. Co.  
**Jacksonville** (7,650). Jacks. St. RR. Co.—*Pr* H. S. Haines, *Spt* Geo. W. Haines, *Engr* M. H. Motte; 6 m, 3-g, 50 lb T & 35 c; 25 c, 105 m.  
**Pine St. Ry. Co.**—*Pr* Hubbard W. C. and *Sec* Henry S. Ely, *Spt* L. B. Stevens, *Engr* R. N. Ellis; 1 1/2 m, 5 g, 25 lb T; 3 c, 14 m.  
**Orlando** (253). Orl. Spt & Engr. H. Abbott; 6 m, 3 c, 2 m, 10 h.  
**Palatka** (1,616). Palatka St. Ry. Co.  
**Pensacola** (6,845). Pens. St. Car Co.—*Pr* A. V. Chubb, *Sec* Wm. A. Boutin; 3 m, 30 lb T; 7 c, 23 m.  
**Tampa** (730). Tampa St. Ry. Co.—*Pr* C. A. Martinez Ybor, *Sec* T. C. Chamberlain, *Spt* C. E. Parcell; 2 1/2 m, 3-g, 25 lbs; 7 c, 2 stn m, 45 hp.

GEORGIA.

**Athens** (6,099). Classical City St. Ry. Co.—*Pr* G. M. Snodgrass, *Spt* J. H. Dorsey; 3.5 m, 4-g, 16 & 20 lb T; 4 c, 30 m.  
**Atlanta** (37,408). Atlanta St. RR. Co.—*Pr* A. G. Peters, *Sec* J. W. Colpepper, *Spt* E. C. Peters; 2.75 m, 16 & 50 lb; 7 c, 23 m.  
**Gate City St. Ry. Co.** (49 Line St.)—*Pr* R. Peters, *Sec* J. W. Colpepper, *Spt* E. C. Peters; 2.75 m, 16 & 50 lb; 7 c, 23 m.  
**Mar. St. RR. Co.—Pr J. W. Rankin, *Sec* W. A. Hoagwood; 7 m, 20 lbs T; 19 c, 50 m.  
**West End & Atlanta St. RR. Co.—Pr Thomas G. Healy, *Sec* J. A. Scott, *Spt* & *Engr* B. F. Curtis; 3 1/2 m, 20 and 30 lb T; 7 c, 34 m, 1 stn m, 30 hp.)  
**Augusta** (21,891). Augusta Ry. Co.—*Pr* Patrick Walsh, *Sec* & *Spt* E. G. Mosher; 6 m, 5 g, 30 lb T; 13 c, 50 h.  
**Brussels** (2,891). Bruns. St. RR.—*Pr* C. F. Goodyear, *Sec* W. E. Kay, *Spt* U. Dart, *Engr* E. B. Jones; 1 m, 2-g, 25 lb; 2 c, 28 h.  
**Columbus** (10,123). Col. St. RR.—*Pr* R. T. Hankin, *Sec* T. C. Weisger, *Spt* J. B. Weisger; 3 m, 16 lb T; 9 c, 9 h, 27 m.  
**Corington** (—). Corington St. Ry. Co.  
**Macon** (12,749). Mac. City & Suburban St. RR. Co.—*Pr* J. S. Bransford, *Sec* & *Spt* R. T. Voss; 10 m, 5-g, 20 lbs T; 26 c (18 close, 6 open), 8 h, 32 m.  
**Rome** (3,577). Rom. St. Ry. Co.—*Pr* Geo. W. Land.  
**Savannah** (30,709). "City & Suburban"—*Pr* Jas. H. Johnston, *Spt* Geo. W. Alley; 17 m, 16 m in city, 10.5 m suburban; 44 c, 30 h, 80 m, 3 stn m.  
**Coast Line R.R. Co.** (See New York). *Sec* & *Spt* R. E. Cobb; 7 m (2 m in city), 5 g, 35 lb T and ch; 21 c, 34 m, 1 stn m.****

ILLINOIS.

**Alton** (8,975). Alt. & Cr. Alton Horse Ry. & Carrying Co.—*Pr* John Haley, *Sec* Chas. H. Hays, *Spt* Wm. H. Hays; 2.75 m, 37 lb T; 5 c, 18 h.  
**Aurora** (11,875). Aur. City Ry. Co.—*Pr* H. H. Evans, *Sec* J. H. Day; 6 m, 25 lb; 9 c, 6 h, 49 m.  
**Bloomington** (17,184). Bl. & Normal Horse Ry. Co.—*Proprietor* A. H. Moore, *Sec* E. Shary; 5 m, 16 lb T; 12 c, 5 h.  
**Cairo** (9,012). Cairo St. Ry. Co.—*Pr* J. A. Goldstein, *Sec* H. Schulz, *Spt* & *Tr* Thos. Lewis; 3 m, 3-g, 16 & 20 g, 5 c, 12 h.  
**Chicago** (563,300). Chicago Ry. Co. (5020 State St.)—*Pr* & *Spt* C. B. Holmes, *Sec* H. H. Windsor, *Engr* C. J. Lusk; 104.25 m, 45, 65 and 78 lb; 829 c, 160 g; 1659 h, 3 stn m (30 hp), 6 engines (200 hp), 200 m, 100 ft. 200 ft.  
 \*Chicago Passenger Ry. Co.—*Pr* H. Weeks; 22 m; 75 c, 580 h.  
 \*Chicago West Division Ry. Co. (59 State St.)—*Pr* J. Russell Jones, *Sec* G. L. Webb, *Spt* De Witt C. Cregier; 100 m, 45 and 52 lb; 1,000 c, 4,200 h.

\*North Chicago Street RR. Co. (444 N. Clark St.)—*Pr* Charles T. Yerkes, *Sec* Hiram Crawford, *Spt* F. L. Threedy; 62 m, 4-8 k, 50 and 60 lb; 254 c, 50 g, 1823 lb; cable engines 2,700 hp.  
**Grandview Pass Ry. of Chicago**—30 m.  
**The Lakeside City St. Ry. Co.**  
**West Chicago** (1,000). West Chicago Ry. Co.—Organized to lease and operate the lines of the Chicago West Div. Ry. Co. and the Chic. Pass. Ry. Co.  
**Danville** (7,745). Citizens' Ry. Co.—*Pr* Wm. P. Chamberlain, *Sec* Adam K. Samuel, 4.5 m, 3-g, 25 lb; 10 c, 20 h.  
**Decatur** (9,548). Citizens' Ry. Co.—*Pr* D. L. Kneiblerger, *Sec* W. L. Kneiblerger, *Spt* W. L. Ferguson; 2.75 m, 20 lb T; 9 c, 16 h, 24 m.  
**East & North Park** (—). East & North Park Ry. Co.  
**East St. Louis** (10,000). E. St. St. Ry. Co.  
**Evanston** (9,700). E. St. City RR.—*Owner* B. L. Payne; 3 m, 26 lb T, 5 c, 18 h.  
**Freeport** (4,200). Freeport St. Ry. Co.—*Pr* Jacob Krohn, *Sec* W. H. Harow, *Spt* J. H. Taylor; 4.5 m, 6 c, 32 h.  
**Galesburg** (11,140). "Chicago City St. Ry. Co.—*Pr* Luke W. Mansboro, *Sec* & *Spt* Geo. K. Clayton; 10 m, 20 and 28 lb; 11 c, 21 h.  
**Jacksonville** (10,927). Jacksonville Ry. Co.—*Pr* Wm. S. Hook, *Sec* T. J. Hook, *Spt* B. P. Miller; 4.5 m, 25 and 50 lb; 16 c, 30 h.  
**Joliet** (11,670). Joliet St. Ry. Co.—*Pr* J. A. Henry, *Sec* John Hulstzer, *Spt* A. Hochman; 3.5 m, 38 lb T; 16 c, 17 h, 20 m.  
**Mechanists** (3,940). Mech. & Buffalo Ry. Co.—*Pr* J. B. Hunter, *Tr* A. T. Thompson, *Spt* J. T. Fullenbender; 3.625 m, 3-g, 10 lb T, 2 c, 4 m.  
**Madison** (7,800). Mad. Central St. Ry. Co.—*Pr* F. H. Wessell, *Sec* W. H. Moore; 1.5 m, 30 lb; 3 c, 10 h.  
**Union St. RR. Co.**—*Pr* Eugene Lewis, *Sec* Geo. H. French; 6 m, 40 lb; 14 c, 40 m, 2 stn m.  
**Peoria** (29,250). "Central City Horse Ry. Co. (2011 N. Adams St.)—*Pr* H. L. Woodward, *Sec* E. Callender, *Spt* John Strong; 10.5 m, 40 lb; 30 c, 40 h.  
**Central Horse & Cattle Ry. Co.** (See Main and Ellis Sts.)—*Pr* H. L. Woodward, *Sec* J. H. Callender; 5 m, 30 lb; 10 c, 20 h.  
**East Hill Peoria Horse RR. Co.**—*Officials* same as Central City H. Ry. Co.; 4 m, 30 lb; 8 c, 20 m.  
 \*Spt Rock Island Ry. (1600 Perry St.)—*Pr* & *Spt* J. N. Hall, *Sec* H. W. Wells; 8 m, 20, 30 and 40 lb; 31 c, 81 m.  
**Peoria Horse RR. Co.**—*Officials* same as Central City H. Ry. Co.; 6.5 m, 45 lb; 20 c, 40 h.  
**Quincy** (27,298). "Quincy Horse Ry. & Carrying Co.—*Pr* Lorenzo Bull; *Sec* E. J. Richmond; 10 1/2 m, 30 lb; 13 c, 13 g.  
**Rockford** (13,429). Rock. St. Ry. Co.—*Pr* A. A. Haines, *Sec* H. H. Robinson, *Spt* Fred Haines; 4.4 m, 30 and 40 lb; 13 c, 52 h, 26 m.  
**Rock Island** (29,100). Rock Island Ry. Co.—*Pr* J. A. Haines, *Sec* J. A. Haines, *Spt* Irwin Johnson; 7 m, 23 c, 69 h, 13 m.  
**M. Hurst**, *Spt* Wm. Gamble; 28,428 ft; 15 c, 41 h.  
**R. Isl. & Milan St. Ry. Co.**—*Pr* & *Spt* B. Davenport, *Sec* E. H. Hurst; 5.5 m, 29 to 30 lb; 16 c, 68 ch, 2 stn m.  
**South Chicago (1,861). Chicago Horse & Dummy Ry.**—*Pr* D. L. Hoff; 5 m.  
**South Chicago City Ry. Co.**—*Pr* Douglas S. Taylor, *Sec* & *Spt* A. Krimbill; 6 m; 7 c, 20 h.  
**Springfield** (19,743). Citizens' St. RR. Co.—*Pr* J. H. Schuck, *Sec* C. Berman, *Spt* J. Bommer; 9.5 m, 3-g, 20 and 30 lb; 20 c, 95 m.  
**Springfield** (City Ry. Co.)—*Pr* Geo. M. Brinkerhoff, *Spt* Irwin Johnson; 7 m; 23 c, 69 h, 13 m.  
**Urbana** (2,942). Urb. & Champaign St. Ry. Co.—*Pr* & *Spt* Wm. Park, *Sec* & *Tr* P. G. Jaques; 2 m, 30 lb; 4 c, 20 h.

INDIANA.

**Elkhart** (6,553). Elkhart Ry. Co.—*Pr* Frederick W. Miller, *Sec* Chas. W. Fish, *Spt* Jas. Kavanagh; 6.5 m, 20 and 30 lb; 9 c, 40, 4 m.  
**Evansville** (10,000). Evansville Ry. Co.—*Pr* Sam Gillett, *Sec* W. S. Gilbert, *Spt* Thos. I. Gist; 12 m, 4-g, 27 lb; 32 c, 220 m.  
**Fort Wayne** (20,580). Citizens' St. RR. Co.  
**Greensburg** (6,643). Greensburg Ry. Co.—*Pr* & *Spt* Dudley Rogers, *Sec* & *Engr* Jas. S. Nutt; 2.25 m, 24 lb; 3 c, 14 h.  
**Indianapolis** (75,550). Citizens' St. RR. Co.—*Pr* A. W. Johnson, *Sec* A. A. Anderson, *Spt* A. W. Johnson; 35 m, 80 c, 600 m.  
**LaFayette** (14,860). L. F. St. Ry. Co. (74 Hartford St.)—*Pr* F. B. Caldwell, *Sec* & *Spt* W. H. Short; 2.25 m, 30 lb; 6 c, 140, 14 m.  
**Loansport** (31,198). Ry. Co.—*Pr* G. Jaques, *Sec* Minnie Jaques, *Spt* W. P. Jaques; 4 m, 4-g, 27 and 30 lb; 9 c, 46 m.  
**Madison** (9,945). Mad. St. Ry. Co.—*Pr* & *Spt* J. Wendell, *Sec* J. K. Weyer; 2.5 m, 4 c, 15 g.  
**Michigan City** (7,360). Citizens' St. RR. Co.—*Pr* W. G. Knight, *Sec* D. Henderson, *Spt* John Lyons; 4 m, 25 lb; 3 c, 4 c, 17 h.  
**Mishawaka** (2,640). South Bend & Mish. St. Ry. Co.—*Pr* J. W. Boynton, *Spt* E. W. Edlinger; 10-g, 30 lb; 13 c, 42 h.  
**Greensburg** (6,643). Greensburg Ry. Co.—*Pr* Geo. T. Vance, *Sec* & *Tr* L. V. Vredenburg, *Spt* W. L. Timbaker; 6.5 m, 4-11 c, 25 lb; 15 c, 15 h, 39 m.  
**Richmond** (17,742). R. City Ry.—*Pr* & *Spt* J. C. Schaller, *Sec* H. I. Miller; 3.5 m, 3-g, 20 lb T; 13 c, 15 h.  
**South Bend** (13,280). South Bend Ry. Co.—*Pr* Jacob Wolverson, *GM* & *Tr* Lucius Clark, *Sec* W. G. George, *Spt* Wm. Miller; 7 m, 30 lb; 16 c, 10 m, 10 m.  
**Terre Haute** (26,042). Ter. H. St. Ry. Co.—*Pr* J. C. Collett, *Sec* J. K. Faddock, *Spt* J. G. Elder, *Engr* H. J. Sprushaw; 3 m; 21 c, 10 h, 86 m.  
**Vincennes** (7,650). Vinc. Citizens' St. Ry. Co.—*Pr* Fred K. Graeter, *Sec* & *Engr* Geo. W. Graciter; 2.5 m, 30 lb; 5 c, 24 m.

IOWA.

**Boone** (3,330). Boone & Boonesborough St. Ry. Co.—*Pr* L. W. Reynolds, *Sec* & *Spt* A. B. Hodges; 1.75 m, 3-g, 20 lb T; 3 c, 8 h.  
**Twin City & Des Moines Ry. Co.**—*Pr* & *Spt* J. B. Hodges, *Sec* S. R. Hainsinger; 14 m, 3-g, 20 lb; 12 c, 8 c, 8 stn m.  
**Burlington** (19,450). B. St. Ry. Co. (1401 Summer St.)—*Pr* John Patterson, *Sec* & *Spt* C. T. Patterson; 2.25 m, 4-g, 8-15 and 20 lb T; 9 c (only 4 run daily), 9 h, 14 m.  
**Union St. Ry. Co.**—*Pr* Geo. A. Duncan, *Sec* & *Spt* F. G. Jones; 8.5 m; 23 c, 50 h, 30 m.  
**Cedar Rapids** (10,104). Cedar Rapids & Marion Ry.—*Pr* A. J. McKeen, *Sec* S. N. Consigny, *Spt* Wm. Emerson; 13.5 m, 30 and 35 lb; 20 c, 9 h, 35 m, 2 stn m.  
**Council Bluffs** (16,063). C. B. St. Ry. Co.—*Pr* S. K. Calaway, *Sec* Geo. W. Hall, *Spt* W. H. Burns; 4.5 m, 27 lb; 10 c, 32 h, 2 m.  
**Davenport** (21,831). Dav. Central St. Ry. Co.—*Pr* Whit M. Grant, *Sec* O. S. McNeil, *Spt* Wm. W. Grant; 14 m, 20 lb; 12 c, 24 h, 15 m.  
**Dav. City Ry. Co.**—*Pr* C. S. Watkins, *Sec* & *Tr* S. D. Bowden; 3.75 m; 14 c, 44 h, 20 m.  
**Des Moines** (22,408). Capital City St. Ry. Co.—*Pr* G. Van Ginkel, *Sec* & *Spt* H. C. Peterson; 14 m, 3-g, 20 lb; 12 c, 32 m.  
 \*Des Moines St. RR. Co.—*Pr* W. M. McCall, *Sec* F. A. Sherman, *Spt* Chas. Grete; 14 m, 3-g, 39 to 52 lb; 25 c, 135 h.  
**Dubuque** (22,255). Dubuque St. Ry. Co.—*Pr* J. A. Rhonberg, *Sec* B. E. Lueban, *Spt* J. J. Linehart; 7.5 m, 52 lb; 22 c, 40 h, 20 m.  
**Keokuk** (12,117). Keokuk St. Ry. Co.—*Pr* James H. Anderson, *Sec* Wm. E. Anderson, *Spt* Wm. E. Anderson; 2 m, 20 lb; 12 c, 25 h, 12 m.  
**Lyons** (4,095). Clinton and Lyons Horse Ry. Co.—*Pr* David Joyce, *Sec* E. W. Joyce, *Spt* Frank Granger; 3 m, 4-g, 25 lb; 7 c, 18 and 30 lb; 15 c, 40 h.  
**Morristown** (6,340). Mats. St. Ry. Co.—*Pr* B. T. Frederick, *Sec* C. G. Gillman, *Spt* A. E. Stiorth; 3 m, 4-g, 25 lb T, 7 c, 20 h.  
**Muscatine** (8,235). Mus. City Ry. Co.—*Pr* P. Musser, *Sec* T. R. Fitzgerald; 3.5 m, 3-g, 21 lb; 11 c, 40 h.  
**Ottumwa** (9,004). Mineral Springs St. Ry. Co.—*Proprietors* L. E. Fray & Co.; 1 m, 3-g, 16 lb T; 1 c, 4 g, 2 h, 13 m.  
**Ott. Ry. Co.**—*Pr* A. H. Hedrick, *Sec* & *Tr* H. L. Hedrick, *Spt* C. M. Hedrick; 2 m, 3-g, 27 lb; 4 c, 2 h, 13 m.  
**Red Oak** (3,755). Red Oak St. Ry. Co.—*Pr* John Hayes, *Sec* F. M. Byrket, *Spt* & *Tr* M. Boham; 1.5 m, 4-g, 25 c, 2 h, 2 m.  
**Sevastopol** (35). Des Moines & Sevastopol St. Ry. Co.—*Pr* G. Van Ginkel; 1.5 m, 4-g, 35 lb; 12 c, 15 h.  
**Sioux City** (7,360). "Sioux City St. Ry. Co.—*Pr* & *Spt* Fred T. Evans, Jr., *Sec* James F. Peaney; 10 m, 4-g, 45 lb; 20 c, 100 h, 50 m.  
**Watauga** (1,830). Watauga St. Ry. Co.—*Pr* W. H. Hartman, *Sec* T. N. Kellogg, *Spt* J. A. Foye; 2 m, 3-g, 20 lb; 3 c, 19 h.

KANSAS.

**Abilene** (2,360). The Ab. St. Ry. Co.—*Pr* & *Spt* M. M. Shippe, *Sec* C. G. Hawk; 2.25 m, 20 lb T; 4 c, 5 c, 15 h.  
**Ashland** (—). Ash. St. Ry. Co.  
**Atchison** (15,105). Atchison St. Ry. Co.—*Pr* J. H. Beeson, *Sec* J. C. Tomlinson, *Spt* J. G. Thayer; 6.5 m, 18 to 45 lb; 17 c, 13 h, 42 m.  
**Clay Center** (1,043). Clay Center St. Ry. Co.—*Pr* W. H. Stratton, *Sec* & *Tr* Wm. Sharpe, *Spt* O. E. Walker; 1 m, 25 lb T; 2 c, 8 m.  
**Council Grove** (1,043). Council Grove St. Ry. Co.—*Pr* W. H. White, *Sec* H. W. Glidemeister, *Spt* Lewis Menz; 1 m, 3-g, 6 lb T; 2 c, 2 h, 2 m.

# FRANK H. ANDREWS,

SUCCESSOR TO

ANDREWS & CLOONEY, F. T. LERNED, Gen'l Agt.

MANUFACTURER AND CONTRACTOR FOR

## CONSTRUCTING STREET RAILWAYS.

THE BUILDING OF

# CABLE ROADS

AND FURNISHING MATERIALS FOR SAME, A SPECIALTY.

*All kinds of Steel and Steel Grooved Rails, Straight or Bent to any Radius. Knees, Fishplates, Spikes, Bolts, Etc., Etc.*

## MACHINERY:

*Wheel Presses, Wheel Boreers, Axle, Lathes, Drills, Etc., either for Steam or Hand Power.*

PROMPTNESS AND REASONABLE PRICES.

SEND FOR ILLUSTRATED CATALOGUE.

BRANCH OFFICES:

**BOSTON,**

37 Central Street.

**ST. LOUIS,**

Southern Hotel.

**CHICAGO,**

Lakeside Building.

Represented in California by WM. B. ISAACS, 258 Market Street, San Francisco.





# CAR HEATING

WITH CLINE'S PATENT HEATER AND

## Aromatic Carbonic Compound Composition Fuel



CHEAP. CONVENIENT. SAFE.

Once Filling lasts 18 hours.

NO CUTTING OF CAR TO PUT IN.

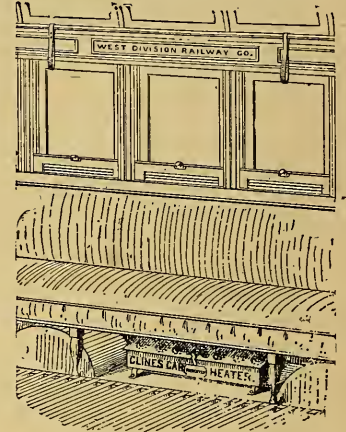
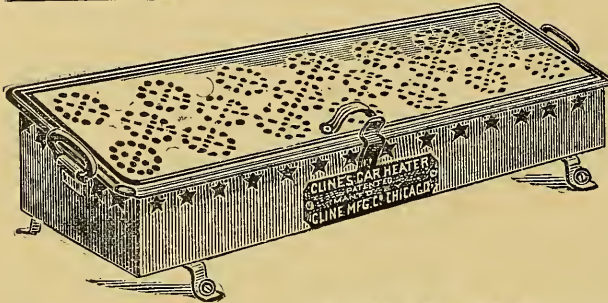

### ADOPTED BY THE FOLLOWING ROADS:

Office of THE CHICAGO FIRE UNDERWRITERS' ASSO.,  
157 to 163 LaSalle Street, Rooms 31 & 33.

T. A. BOWDEN, Sup't of Surveys.

D. C. CREGIER, Sup't West Div. Railway Co.

Chicago, Ill., Oct. 28, 1886.

Dear Sir—I have examined into the Cline Manufacturing Co.'s Heater, also Cline's Aromatic, Carbonic, Composition Fuel, and I see no reason why you should not put them in the cars, provided they are securely fastened down to the floor; and when fire is applied to them it should be carried around in a metal can, and a small shovelful dropped into the stationary heater when in the car. Also in no case should there be hay in the car when the heater is fired up. Yours truly,

T. A. BOWDEN, Sup't of Surveys.

CHICAGO WEST DIVISION RAILWAY COMPANY,

Office of the Sup't, DeWITT C. CREGIER.

To whom it may concern.

Chicago, Jan. 21, 1887.

This is to certify that this company has in use over 200 Cline's Heaters in their cars. Respectfully, DeWITT C. CREGIER, Sup't.

SOUTH CHICAGO CITY RAILWAY CO.,  
Room 46 Calumet Bld'g, 191 LaSalle St.

Messrs. L. Cline & Bro., Chicago.

Chicago, Feb. 8, 1887.

Gentlemen:—We have used your Heaters in our cars since the first of December last, and have found them entirely satisfactory. During the coldest weather the temperature in the cars has been maintained at about 45 degrees. We cheerfully recommend the Cline Heater to other street railroads.

D. S. TAYLOR, Pres't.

W. H. HARTMAN, Pres't.

T. N. KELLOGG, Sec'y & Treas.

J. A. FOYE, Vice Pres't & Sup't.

Office of WATERLOO STREET RAILWAY CO.,  
Cline Mfg. Co., Chicago.

Waterloo, Iowa, Feb. 5, 1887.

Gents:—We are just testing your Heaters. We are well pleased with the results thus far. There is no question but that two of them will heat a 12 foot street car when the mercury is "way down" below zero. I think you have at last solved a "long felt want." Very respectfully yours,

Waterloo Street Railway Co., by W. HARTMAN.

W. S. ROBINSON, Pres't.

D. C. KELLOGG, Vice Pres't.

Office of CITY OMNIBUS COMPANY,

68 South Canal Street,

F. R. HITT, Sec. & Treas.

S. J. RUSSELL, Supt.

Chicago, Feb. 5, 1887.

Gentlemen:—We are using the Cline Manufacturing Company's Heater and Fuel this winter in our Omnibuses, and find it makes one-half difference in the increase of the travel. I would recommend it to any Omnibus or Car Company, as they will never do without it if they use it once. We could not get along without it and cheerfully recommend it to the public. Respectfully,

S. J. RUSSELL, Sup't.

R. PATRICK & CO., BANKERS.

Cline Mfg. Co., Chicago.

Pittsburg, Feb. 12, 1887.

Dear Sir:—We have in use on the Pittsburgh and Birmingham Passenger R. R. cars, the Cline & Bro. Patent Heater and Fuel. Having used the same for the past two months they have given us entire satisfaction and contributed to the comfort and pleasure of our patrons. Respectfully,

W. W. PATRICK, Pres't.

President's Office, RICHMOND CITY RAILROAD,

J. C. SHAPPER, Pres't.

Cline Mfg. Co., Chicago, Ill.

Richmond, Ind., Feb. 28, 1887.

Gents:—Your favor of Feb. 28 received and noted. We used your heater such a short time that we hardly feel competent to speak about its value. It gave satisfaction during the time it was in use. Next winter we will give it a more thorough test. Yours truly,

J. C. SHAPPER.

CHICAGO WEST DIVISION RAILWAY COMPANY,

Office of the Superintendent.

DeWITT C. CREGIER, Supt.

To whom it may concern:

Chicago, July 21, 1887.

The Cline Car Heater was placed on a number of the cars of this company during last winter, giving good results so far as known.

DeWITT C. CREGIER, Sup't.

# Cline Manufacturing Company,

277 & 279 S. CANAL ST., CHICAGO, ILL.











**Reading** (43,278). Perkiomen Ave. Pass. Ry. Co. (Perkiomen Ave. & 19th St.)—*Pr* Gas. Ironbr. Sec Isaac Hiestor, Spt John B. Houpp; 4.5 m, 5-24 k, 38 lbs and 45 lb, 28 c, 7.5 m, 10-12 k, 38 lbs, 38 c.  
 \*Leading City Pass. Ry.—*Pr* Henj. F. Owen, Sec H. A. Mullenback, Spt J. A. Higgins; 2.2 m, 5-2 k, 45 lb; 22 c, 66 lb.  
**Scranton** (229). Scranton Ry. Co.—*Pr* H. Edinger.  
**Syracuse** (15,850). People's St. Ry. Co.—*Pr* Wm. Matthews, Sec Horace E. Hand, Spt F. Poore; 10 m, 25, 40 and 52 lb; 20 c, 60 lb.  
**Soc. Suburban** (1,000). Soc. Suburban Ry. Co.—*Pr* Geo. G. Sanderson, Spt B. F. Kilham; 4 m, 4-8 k, 35, 40 and 52 lb; 20 c, electric power (Van Depoelle system); engines, 350 hp.  
**The Noyah** (Cantonment RR. Co.—*Pr* G. Clark, Sec T. C. Snow; 5 m, *Steeles* (2,447). Steeles Hill Ry. Co.  
**Strodsburgh** (3,580). Stron. Pass. Ry. Co.—*Pr* S. T. & Tr J. Lantz, Sec Jacob Houser; 10 m, 25 and 30 lb; 4 k, 7, 3 m, 11 lb.  
 \**Wiles* (23,333). Coalville Pass. Ry. Co.—*Pr* H. W. Kirkland, Sec G. Lovell, Spt A. S. Orr; 2.5 m, 20 and 24 lb; 3 c, 12 lb.  
 \**Wilkes* (23,333). Wilkes Barre Ry. Co.—*Pr* Wm. J. Harvey, Sec A. J. Davis; 3 m, 5-2, 40 and 45 lb; 11 c, 22 lb.  
 \**Williamsport* (18,349). Williamsport Ry. Co.—*Pr* H. P. Allen, GM S. A. Pitt, Jr, Sec R. J. Ober; 3.5 m, 36 lb ch; 7 (one lb), 26 lb.  
**York** (13,940). The York St. Ry. Co. (West Market St.)—*Pr* W. H. Lunin, Sec D. K. Trimmer, Spt J. Fiddler; 3 m, 7 c, 66, 13 lb.

**RHODE ISLAND.**

**Providence** (19,030). \**Pawtucket* St. Ry. Co.—*Pr* Arnold R. Chace, Sec B. A. Jackson, VP & GM D. F. Longstreet; 8 m, 4 g, 54 lb; 21 c, 113 lb.  
*Providence* (19,037). \**Union* Ry. Co.—*Pr* Josse Stearns, VP & GM D. F. Longstreet, Sec G. A. Hazzard, *Butte* Geo. C. Fudge; 5.3 k, 30 m, 47 and 54 lb; 280 c, 1294 m (May 1).

**SOUTH CAROLINA.**

**Charleston** (49,984). Char. City Ry. Co. (4 Broad St.)—*Pr* John H. Higgs, Sec Evan Edwards & Frank F. Whitten, Spt John H. Mollenhott; 10 m, 4-8 k, 38 and 42 lb ch; 30 c, 116 lb, 1 mt.  
*Entirely new* (11,000). \**Charleston*, Sec W. E. Hayne, Spt T. W. Passalunghi; 16 m, 5-9, 42 lb ch; 34 c, 67, 31 m.  
**Columbia** (10,026). Col. St. Ry. Co.—*Pr* K. S. Pierson (New York), Sec E. M. Cole (32 Liberty St., N. Y.).  
**Greenville** (6,159). Street Ry. Co. of the City of Greenville (104 Washington St.)—*Owners* Fowler & Reilly; *Pr* C. G. Towler, Sec G. G. Weiss, Spt P. H. Henry; 2.25 m, 5-9 k, 30 lb, 7 c, 66, 13 lb.  
*Monticville* (—). Middle St. Sullivan's Island RR. Co.—*Pr* B. C. Callaghan, Sec F. P. Widen, Spt L. Hinkey; 2.5 m, 4-8 k, 20 lb T; 7 c, 1 lb, 13 m.

**TENNESSEE.**

**Athens** (1,100). The Athens Mineral Land & Improvement Co.—*Pr* T. M. Burket, Sec W. D. Henderson; 1 m, 20 lb T; 1 c, 4 m, 1 st m.  
**Chattanooga** (12,822). City St. RR. Co.—*Pr* J. H. Warner, Sec C. R. Gaskill, Spt Geo. Sutherland, Spt Geo. J. H. Snelson; 4.5 m, 10-12 k, 38 lbs, 38 c.  
**Clarksville** (3,860). Clarks, St. Ry. Co.—*Pr* J. F. Snelson, Sec C. W. Faxon; 2 m, 10 lb T; 4 c, 18 m.  
**Jackson** (3,377). J. E. Jackson & Stribarst St. Ry. Co.—*Pr* O. H. Heath (Sioux City, Ia.), Sec R. B. Crawford (Wayne, Neb.).  
**Knoxville** (9,693). \**Knoxville* St. RR. Co. (538 Broad St.)—*Pr* W. P. Chamberlain, Sec T. L. Beaman, Spt J. H. Moore; 7 (12 c), 32 k.  
 \**Matuy Bell* Ave. & *Hartlee* St. Ry. (336 Broad St.)—*Pr* John S. Van Gilder, Sec T. L. Beaman, Spt Jas. Moen; 4 m, 22 lb ch; 4 c, 28 lb.  
 \**Market Square* (10th & 11th Sts., 150 Day St.)—*Pr* W. C. Henderson, Spt L. O. Rogers, Engr Murray Nicholson; 2 m, 22 lb ch; 4 c, 15, 8 m.  
**Memphis** (33,550). Citizens St. RR. Co. (474 Main St.)—*Pr* Napoleon Hill, VP & GM Thos. Harrell, Sec H. Dudley Fryar; 40.5 m, part 5.0, 38 lbs ad 45 lb; 160 c, 604 m.  
**Union Rte. Co.**—14 m.  
**Nashville** (43,350). McGavock & Mt. Vernon Horse RR. Co. (91 N. Cherry St.)—*Pr* John P. White, Sec B. B. Stobolfield, Spt Daugherfield Deaerick, Engr Wilber F. Foster; 14.25 m, 5 g, 16 to 28 lb; 4 c, 300 m.  
 \**Nash* & *Edgefield* St. RR. Co. (91 N. Cherry St.)—*Pr* Jas. H. Yarborough, rest of officials same as McGavock & Mt. V. H. RR. Co.; 6.25 m, 2 g, 16, 20 and 38 lb; 21 c, 101 m.  
**Overland Ry. Co.**—*Pr* O. F. Noel, Sec & Tr Jas. F. Caldwell; 9.5 m, 45 lbs; 6 c, 3 st m.  
**South Nash. St. RR. Co.**—*Pr* W. M. Duncan, Sec & Spt C. L. Fuller; 4.5 m, 5 g; 16, 20 and 32 lb; 12 c, 72 m.

**TEXAS.**

**Austin** (10,980). Austin St. Ry. Co.  
**Brenham** (4,101). Br. St. RR. Co.—*Pr* T. J. Pampell, GM E. B. Randle, Sec John A. Kane; 2 m, 4 g, 20 lb; 3 c, 18 m.  
**Dallas** (13,358). Dallas St. Ry. Co.—*Pr* I. E. Henderson, Sec W. C. Connor, Spt S. S. Klugberg; 13 m; 25 c, 1 m, 200 m.  
**Denison** (10,375). Denison St. Ry. Co.—*Pr* C. A. Waterhouse, Spt J. J. Campbell; 4.5 m, 10 lb T; 4 c, 18 m.  
**El Paso** (750). El P. St. Ry. Co.—*Pr* J. F. Crosby, Sec & Spt G. N. Marshall; 6 m; 18 c, 40 m.  
**Fort Worth** (8,063). Ft. Worth St. Ry. Co.—*Pr* K. M. Vanzandt, Spt J. T. Payne; 7.5 m, 4 g, 25 and 28 lb; 16 c, 86 m.  
**Gainesville** (2,650). Gains. St. Ry. Co.—*Pr* Sam Lazaros, Sec & Spt Zac. Farmer; 3 m, 22 lb; 9 c, 18 m.  
**Galveston** (32,348). \**Galveston* City RR. Co. (P.O. Box 373).—*Pr* Wm. H. Sinclair, Sec F. J. DeMerit, Spt M. J. Keenan; 25 m, 25 and 30 lbs; 1; 79 c, 214 m.  
**Gulf City Ry. & Ice Co.**—*Pr* H. R. Burnett, Sec Thos. C. Becker, Spt Criss Hammerhus; 13 m, 4 g, 20, 25 and 30 lbs; 27 c, 104 m.  
**Houston** (16,133). Hous. City St. Ry. Co. (30 Travis St.)—*Pr* Wm. H. Sinclair, GM H. F. McGregor, Sec H. Bailey, Spt Henry Freund; 15 m, 30 lb; 40 c, 114 m.  
**Lampasas** (653). Lam. Springs St. RR. Co.—Sec W. H. Little, Spt E. R. Maddox; 2.5 m, 22 lb; 9 c, 18 m.  
**Longview** (1,525). Longview St. RR. Co.—*Pr* Geo. D. Harrison, Sec F. L. Whaley, Spt Geo. D. Harrison; 75 lb, 3 g, 6, 10 lb; 2 c, 3 m.  
**Paris** (3,390). Paris Ry. Co. (P.O. Box 375).—*Pr* D. E. Latimer, Sec & Spt C. G. Gwyness; 1.5 m, 22 lb T; 7 c, 38, 4 flats; 13 m, 3 st m.  
**San Antonio** (20,590). Prospect Hill St. Car. Co.—*Pr* Sam Slavick, VP & Spt J. A. Ross; 3 m, 10 lb T; 4 c, 18 m.  
 \**Sau Antonio* St. Ry. Co.—*Pr* A. B. Belknap, Sec E. R. Norton, Spt J. Rohb; 18 m, 4 g, 35 lb; 40 c, 150 m.  
 \**Sherman* (4,083). Sherman St. Ry. Co.—*Pr* C. W. Batsell, Sec C. W. Batsell, Jr, Spt J. M. Batsell; 4 m, 5 g, 16 and 20 lb T; 9 c, 50 m.  
 \**Waco* (7,295). Waco St. Ry. Co.—*Pr* E. Kotan, Sec W. R. Keilum, Spt J. W. Sedwitt; 7.5 m, 14 and 16 lb; 14 c, 54 m.

**UTAH.**

**Ogden City** (6,069). Og. City Ry. Co.—*Pr* L. W. Shurtliff, VP & Spt O. P. Arnold, Sec & Tr H. S. Young; 3 m, 20 lb; 4 c, 19 m.  
**Salt Lake City** (75,785). Salt Lake City Ry. Co.—*Pr* John B. Whithead, Sec Dd. McKenzie, Spt Orson F. Arno; 12 m, 20 lb T; 20 c, 7 lb, 100 m.

**VERMONT.**

**Burlington** (11,365). Winooski & Barre Horse RR. Co.—*Pr* W. A. Woodbury, Sec Geo. Wales, Spt K. B. Walker, Engr Jos. Depp; 3 m, 4-8 g, 25 lb T; 8 c, 30 lb.  
**Rutland** (7,502). Rut. St. Ry. Co. (7½ Cent St.)—*Pr* J. N. Woodfin, Sec Geo. H. Cheney, Spt M. McKee; 8.5 m, 20 lb T; 9 c, 30 lb.

**VIRGINIA.**

**Lynchburg** (15,959). Lyn. St. Ry. Co.—*Pr* & Sec Stephen Adams, Spt W. M. Payne, 4 m, 5-1 g, 20 and 26 lb; 7 c, 15 b, 23 m.  
**Norfolk** (21,300). The Norfolk City Ry. Co.—*Pr* John B. Whithead, Sec & Tr H. C. Whiteaker, Spt E. W. Sawyer; 3.25 m, 5-2 k, 40 lb; 20 c (18-w-20 c, 2 one-h), 70 lb.  
**Petersburg** (10,530). \**Pet. St. Ry.*—George Beadle, proprietor; 3.5 m 42 and 47 lb; 9 c, 2 b, 30 m.  
**Richmond** (16,300). \**Rch. St. Ry. Co.*—*Pr* J. L. Schoolcraft, G M C. M. Bolton, Spt R. C. & Manchester Ry. Co.—*Pr* E. Taylor, Sec & Tr Jackson Brandt, Spt B. E. Seiden; 3.5 m, 38 lb; 5 c, 26 lb.  
 \**Union* Pass. Ry. Co.—Sec & Tr John F. Barry; 13 m; Sprague electric mtr.

**WASHINGTON TERRITORY.**

**Seattle** (3,533). The Seattle St. Ry. Co.—*Pr* & GM F. W. Osgood, Sec Geo. Klinecar; 4.5 m, 25 and 35 lb; 7 c, 25 lb.  
**Spokane Falls** (350). The Spokacee St. Ry. Co.—*Pr* W. J. Biowa, VP & GM A. J. Ross, Sec & Tr H. C. Marshall; 2.5 m, 30 lb; 5 c, 13 lb.

**WEST VIRGINIA.**

**Wheeling** (30,736). Citizens Ry. Co.—*Pr* Dr. Geo. H. Caldwell, Sec Frank P. Hall, Spt Michael Loftus; 10 m, 2, 25 k, 45 lb; 19 c, 59 lb.  
 \**Wheeling & Elm Grove RR.*—*Pr* J. D. Dubois, Sec E. J. Hutter, Spt C. Hirsch; 7 m, 30 lb; 12 c, 4 st m (Baldwin's).  
**WINDSOR.**  
**Apleton** (9,005). Apl. Electric St. Ry. Co.—*Pr* J. E. Harriman, Sec Frank W. Hartman, Spt J. H. King, Spt C. M. Edwards; 1.5 m, 33 lb; 5 c, 5 electric motor (Van Depoelle system).  
**Eastlake** (10,119). East. City St. Ry. Co. A. Bradstreet (35 Pine St., New York, Sec Westwood Lewis, Spt J. H. Harrigan, Engr G. W. Baldwin; 4.5 m, 16 c, 36 lb, 49 m.  
**Janeville** (9,019). Janes St. Ry. Co.—*Pr* Stephen G. Clarke (1525 N. Halsted St., Chicago), Sec John P. Atledge, Spt Chas. Atwood; 4.5 m, 5 g, 19 lb 2 m.  
**La Crosse** (34,505). La. City Ry. Co.—*Pr* B. K. Edwards, Sec J. T. Dazert, Spt P. Valer and Geo. F. Smith; 5.5 m, 4 g, 40 to 50 lb; 19 c, 62, 4 m.  
**Madison** (15,749). Oak St. RR. Co.—*Pr* L. W. Kears, Sec H. W. Jones, Spt & Engr Am. H. Kuntzler; 2 m, 4 g, 2 1/2 m, 4 c, 2 (two-h), 6 one-h, 4 lb, 20 m.  
**Milwaukee** (115,577). \**Green* City RR. Co. 439 East Water St.; *Pr* Winfield South, Sec Westwood Lewis, Spt J. H. Harrigan; 27 c, 10 use, 438 use, 11 Milwaukee Cable Ry. Co.  
 \**Milwaukee* City Ry. Co. 1209 West Water St.—*Pr* Peter McEneaney, Sec Geo. D. Wincless, Spt Geo. Krumpholtz; 3.3 m, 45 lbs; sec, 374 c, 72 m.  
 \**West Side* St. Ry. Co.—*Pr* W. Becker, Sec Thos. J. Ibrum, Spt A. McNaughtin, Newark (4,202). Newark St. Ry. Co.—*Pr* L. Cloutier, Sec J. Y. Hull, Spt L. P. Thompson; 4 m, 27 lb; 10 c, 40 lb.  
**Roeline** (10,041). Belle City St. Ry. Co. (716 Park Av.)—*Pr* A. Spt Geo. B. Hathaway Sec J. E. Dodge; 4 m, 4 c, 32 lb, 9 c, 11 lb.

**CANADA.**

**ONTARIO.**

**Belleisle** (9,516). Belleisle St. Ry. Co.—*Pr* D. Lockwood, GM & Sec S. A. Lockwood; 2.13 m, 25 lb; 5 c, 1 lb.  
**Brantford** (9,616). Brantford St. Ry. Co.—*Pr* A. A. Flack, GM & Sec Chas. H. Flack; 5 m, 10 g, 25 lbs; 9 c, 20 lb.  
**Chatham** (9,373). Chatham St. Ry. Co.—*Pr* J. H. Smith, Spt J. H. Smith; 4 m, 3-6 g; 10 c, 30 lb.  
**Kingston** (35,961). Hous. St. Ry. Co.—*Pr* Robert J. Carson, Sec & Tr F. L. R. Kent; 4 m, 3-6 g; 10 c, 30 lb.  
**London** (19,746). \**London* St. Ry. Co.—*Pr* V. Cronyn, Sec Jas. H. Flegg, Spt Henry Thos. Smith; 6 m, 30 lbs; 22 c, 36 lb.  
**Niagara Falls** (—). Niag. F. Wesley Park & Cliffon Tramway Co.—*Pr* John H. Mooney (40 Wall St., New York), Sec & Spt H. Bache; 4.3 m, 30 and 45 lb; 12 c, 45 lb.  
**Ottawa** (24,412). \**Ottawa* City Pass. Ry. Co.—*Pr* Thos. C. Keefer, Sec Jas. D. Fraser; 5 m, 30 lb; 9 c, 40 lb.  
**St. Catharines** (3,671). St. Catharines, Merrillon & Thorold St. Ry. Co.—*Pr* & Spt E. A. Smyth, Sec A. P. Friedman; 5.75 m, 30 lb; 8 c, 36 lb. Electricity (Van-Depoelle system) to be applied.  
**Thornton** (3,867). St. Catharines, H.R. Co.—*Pr* J. S. Griffin, Sec Geo. Wegg, Spt Wm. J. Palmerston; 1.25 m, 3-6 g, 30 lb; 5 c, 9 lb.  
**Sarnia** (3,874). Sarnia St. Ry. Co.—*Pr* J. F. Lester, Sec & Tr Thos. Symington, Spt Henry W. Moore; 5 m, 30 lb; 10 c, 30 lb.  
**Toronto** (86,415). \**Tor. St. Ry. Co.*—*Pr* Frank Smith, Sec James Gann, Spt John J. Franklin; 50 m, 4-10 k, 30 lb; 180 c, 865 lb.  
**Windsor** (6,581). Sandwich & Windsor Pass. RR. Co. Windsor Electric St. Ry. Co.—*Pr* W. M. Boozer, Sec A. H. Joseph, Spt W. C. Turner, Engr P. C. Poinliff; 1.25 m, 2 c; 1 electric mtr (Van Depoelle system), engine 15 hp.

**QUEBEC.**

**Montreal** (140,747). \**Mont. St. Ry. Co.*—*Pr* Jesse Joseph, GM & Sec E. Lusher, Spt T. H. Robinson; 30 m, 45 lb; 100 c, 715 lb.  
**Quebec** (10,490). Quebec St. Ry. Co.—*Pr* St. Joseph, Spt Chas. St. Michel, Sec Tr & Spt Samuel Moore; 3 m, 4-8 k, 45 lb; 9 c, 44 lb.  
 St. John St. Ry. Co. (Lim.) (502-505 St. John St.)—*Pr* Jos. W. Henry, GM & Sec W. W. Clark; 1.3 m, 4-8 k, 35 lb T; 4 c, 4 omnibuses, 23 lb.

**MANITOBA.**

**Winnipeg** (14,000). The Winnipeg St. Ry. Co.—*Pr* Jas. Austin, Sec & GM Albert W. Austin, Spt Geo. A. Young; 5 m, 35 lb; 15 c, 45 slights and omnibuses, 100 lb.

**NEW BRUNSWICK.**

**St. John** (26,127). St. John St. Ry. Co.—*Pr* John R. Bothwell; 7 m, 45 and 60 lb r 1 c, 65 lb. Offices, Room 38 Drexel Building, New York, and St. John, N. B.

**NEW YORK.**

**Halifax** (36,100). Halifax St. Ry. Co. (Lim.)—*Pr* John Bothwell, Sec & Tr H. B. Geley, Spt J. G. Macdonald; 7 m, 45 and 60 lbs; 15 c, 65 lb. Offices, Room 39 Drexel Building, New York, and Halifax, N. S.

**MEXICO.**

**Chihuahua** (12,000). Chihuahua St. RR. Co.—GM A. Gonzalez, Jr.  
**Corova** (4,396). Ferro-Carril Urbano de Corova—GM Jose Antonio Cabral; 2 m, 3-10 g; 5 c, 46 m.  
**Jalapa** (10,000). Jalapa Tramway (Branch of the Mexican Ry.)—*Pr* T. C. Saunders, Sec J. F. Debutson, Spt John Thirakill; 61.25 m; operated by mules and horses. Offices, 45 New Broad St., London, Eng., and Jalapa.  
**Matamoros** (20,000). Matamoros St. Ry. Co.—*Pr* J. Cruz—*Owner* Francisco Armandiz; 7 m, 4-11 g, 36 lb; 13 c (8 spass), horses and mules.  
**Merida** (45,000). Merida St. Ry.—Proprietor Knud G. Canton.  
**Mexico** (200,000). District St. Ry. Co. of the City of Mexico—Compania Limitada de Ferrocarriles del Distrito, Callejon de Betanietas No. 12.—*Pr* Angel Lerdo de Tejada, 2 Administrador General F. J. de Castillo; 91 m, 30, 40 and 70 lb; 226 c, 45 b, 1500 m.  
 Circuito de Baños St. Ry.  
**Monterrey** (25,000). Monterrey and Santa Catalina Ry. Co.—*Pr* W. L. Heermans (318 Greenwich St., New York), VP & GM A. G. Schuyler, Sec Frank Rook, Spt Sam. H. Fisk; 10.5 m, 3-6 g, 25 lb T; 18 c (15 spass, 3 frt), 60 m.  
**Nuevo Laredo** (30,000).  
**Tehuacan** (12,000). Ferro-Carril Nacional de Tehuacan a Esperanza (Tehuacan and Esperanza Tramway).—*Pr* Ramon Fernandez, GM Fernando de Maria y Campos, Spt Tellez Truarez; 31 m, 10 lbs; 62 c (Stephenson's) 200 m.  
 Vera Cruz (16,000). Vera Cruz St. Ry. Co.—*Pr* E. Moscar.

**CENTRAL AMERICA AND WEST INDIES.**

**CUBA.**

**Havana** (25,000). Havana City Ry.—12 m, 52 c, 5 st m.  
 Regia and Guanabacoa Tramway—38 m, 19 c, 5 st m.  
**Mallorca** (—). Mallorca Ry.—1.65 m.  
**Sau Miguel de Novitas** (—). Sau Miguel and Baga Ry.—5.5 m, 45 lb.

**HAWAII.**

**Port au Prince** (35,000). Port au Prince St. Ry. Co.—*Pr* & Tr C. Lundmann (55 and 57 Beaver St., New York), VP & GM R. T. Cline; 4 m, 3-6 g, 20 (10 spass).

**PORTO RICO.**

**Aquidilla** (—). Tramway of the Estate "Casualidad."—GM Carlos Aiers; 1.25 m, 1-1 1/2 g, 30 c.  
 Tramway of the Estate "Cotosa."—GM Emilio Yañez; 1.25 m, 1-1 1/2 g, 30 c.  
 Tramway of the Estate "Milagro."—GM & Owners Ameli J. & Co.; 2.5 m, 1-7 1/2 g, 40 c.  
**Puerto Plata** (—). Muelle Nuevo Tramway.—*Owners* Jose Sinebra and associates, GM Thos. Simpson, Spt Ed. Bugaria; 1.25 m, 4 g, 16 lb; 22 c (platform).  
**SAN SALVADOR.**  
**San Salvador** (18,500). San Salvador and Santa Tecla Tramway (built by Government).—*Owner* F. Camacho, of Guatemala.

**SOUTH AMERICA.**

**ARGENTINE REPUBLIC.**

**Buenos Ayres** (295,000). Anglo-Argentine Tramway (4 Cophall Buildings, London, and at Buenos Ayres).—*Local Dir* J. B. Wauklyn, Sec Louis Streim; 27 m, 42 lbs; 119 c, 659 lb.

Boca y Barraza Tramway of Buenos Ayres.—3.33 m, 40 lbs; 10 c, 300 h.  
 Buenos Ayres y Belgrano Tramways Co., Limited.—*Man* Dr J. B. Wanklyn,  
*Sec* Jas. Anderson (31 Moorgate st., London); 14 m, 40 lbs; 56 c, 430 h.  
 Central Tramway of Buenos Ayres.—15.5 m, 40 lbs; 32 c, 536 h.  
 City of Buenos Ayres Tramways Co., Limited.—*GM* H. W. Ford, *Sec* John  
 Heaton (1, Winchester st., London); 32.87 m, 40 lbs; 187 c, 1,500 h.  
 Concordia (—).—Tramway del Comercio.—*Owner & GM* Federico Zorraquin;  
 3.5 m, 3-10 g; 25 lb; 8 c, 50 h.

**BRAZIL.**

Bahia (128,929). Companhia de Ferro-Carril Transportes Urbanos.—*Spt* Theodor  
 de Gomes; 20.5 m, 40 lb; 69 c, horses and 6 stn ur; stationary engine for  
 inclined plane, and a hoisting machine 131 feet lift.  
 Vehiculos P.omaticos.—*GM* Sr Joaquim Per. Caryalho; 5 m.  
 Niteroy (—). Niteroy Tramway.  
 Pernambuco (116,773). Ferro-Carril de Pernambuco (Rua 1 de Marco 77, Rio de  
 Janeiro).—*Pr* Eduardo Augusto Ribiero, *Sec* Caetano Pinheiro da Fonseca,  
*Spt* Gustavo Adolpho Smith; 18 m, 40 lb; 48 c.  
 Recife (116,671). Recife St. Rly. Limited.—*GM* H. W. S. Bird (Recife). *Sec*  
 J. Burt (65 Moorgate st., London); 14.5 m, 4 g, 45 lbs; 43 c, 21 trucks, 11 stn ur.  
 (Tramways in the city of Recife and suburbs.)  
 Recife and Olinda Rte. (Suburban tramway.)  
 Rio de Janeiro (274,792). Companhia Ferro-Carril do Jardim Botânico.—*Pr* Joas  
 Ribeiro de Alencar, *Spt* S. Miller; 32 m, 43 lb; 90 c, 976 h and 11 m.  
 Empresa do Plano Inclinado de Sta. Theresia.—*Pr & Engr* Januario d'Oliveira;  
 inclined plane 1696 ft, tramway 2 m, 3 g, 20 and 40 lb; 1 stationary engine,  
 70 m.  
 Companhia Ferro-Carril de Sao Christavao.—*Pr* Francisco Pereira Passos; 51  
 lb; 122 c, 1,588 m, 1 stn ur.  
 Santos (9,871). Empresa Carris do Ferro da Villa de S. Vicente.—*Owners & Man*  
 Emmerich & Albes; 6.3 m, 4 g, 8 c, 12 and 56 lb; 18 c, 120 m.  
 Sao Paulo (25,000). Sao Paulo Brazilian Ry. Co., Limited.—*Sec* G. A. Hillier, 111  
 Gresham House, Old Broad st., London; 5 m, 5-3 g, 65 lbs (part of steam  
 railroad), with grade of 1 in 67, operated by cable with 1 stationary engine.

**CHILI.**

Santiago (200,000). Ferro-Carril Urbano de Santiago.—*Pr* Eduardo Maiti, *GM* Ramiro  
 Sanchez; 20 m (3 m in city of Santiago), 48 lb.  
 Valparaiso (97,737). Ferro-Carril Urbano de Valparaiso.—*Sec* Guillermo Law-  
 rence, *Spt & Engr* Egoenio Hammer Carrera; 6 m, 5-6 g, 45 lbs; 55 c.

**ECUADOR.**

Guayaquil (26,000). Guayaquil Tramway.—4 m.

**PARAGUAY.**

Asuncion (16,000). Tramway de la Ciudad de la Asuncion.—*Owners* Wm. Wood-  
 gate & Co. (Buenos Ayres), *GM* Jas. N. Horrocks; 1 m, 40 lb; 6 c.

**UNITED STATES OF COLOMBIA.**

Bogota (100,000). The Bogota City Ry. Co. (Rin 20, No. 1 Broadway, New York).—*Pr*  
 Geo. H. Scavner (333 Clinton Ave., Brooklyn, N. Y.). *VP & Sec* F. W.  
 Allen (1 Broadway, New York), *Spt* James E. Davies (Bogota, U. S. Colum-  
 bia); 8 m, 3-2 g; 16 c, 160 m.

**URUGUAY.**

Montevideo (115,500). Ferro-Carril del Norte (Montevideo to the Barra de Santa  
 Lucia); 11 m.  
 Tranvia Central (Central Tramway); 11 m.  
 Tranvia Cerro; 2.5 m.  
 Tranvia del Este; 4.5 m; 86 c.  
 Tranvia Oriental; 5 m.  
 Tranvia de Paysandú.  
 Tranvia Paso del Molino y Cerro (Montevideo to Cerro); 13.23 m; 30 c.  
 Tranvia a los Podos Buceo y Union; 1 m, 30 c.  
 Ferro-Carril de la Union; 8.33 m; 34 c.  
 All these Uruguayan tramways are operated by animal traction.

**VENEZUELA.**

Caracas (55,638). Caracas Tramway; 3 m.  
 La Guaira (6,763). La Guaira and Magnética Tramway; 1.5 m, 5 g, 30 lb; 2 c.

**GREAT BRITAIN AND IRELAND.**

**ENGLAND AND WALES.**

Accrington (31,435). Accr. Corporation Tramways.—5.4 m, 4 g; 6 c, 6 stn ur.  
 Alford (2,881). Alford & Sutton Tramway Co.—7.05 m, 2-6 g; 4 c, 14 trucks, 3 stn ur.  
 Barrow-in-Furnace (47,111). Barrow-in-Furnace Tramways Co., Limited (33  
 Waterhead, Barrow-in-Furnace).—*Sec* John Fellows, *Engrs* E. Fritchard and R.  
 Yawser; 8.1 m, 3-6 g; 8 c, 7 stn ur.  
 Bath (53,761). Bath Tr. Co.—1.7 m, 4 g; 7 c, 25 h.  
 Birkbeckhead (83,234). Birkbeckhead Tramways Co. (Palm Grove, Cloughton, Birken-  
 head).—*Chr* P. Callender, *Sec & GM* George Lloyd, *Engr* Geo. Hopkins, C.E.;  
 8.75 m; 27 c, 173 h.  
 Birmingham (400,757). Bm. & Aston Tramways Co., Lim. (10 Old Square, Bm.)—  
*Chr* K. Pritchard, *Sec & GM* W. H. Bartley; 6 m; 3-6 g; 26 c, 34 h, 26 stn ur.  
 Bm. Central Tramways Co., Lim. (Old Square, Bm.)—*Chr* J. J. Moore, *GM* C.  
 J. Nicholson, *Sec* W. Holman, *Engrs* Joseph Kincaid, M.I.C.E., and Edward  
 Pritchard, C.E.; 24.56 m, 3-6 g (part); 126 c, 851 lb, 57 stn ur.  
 Birmingham & Western District Tr. Co.—10.8 m, 3-6 g; 32 c, 22 stn ur.  
 Bm. Corporation Tramways are operated by the before-named companies, and  
 each portion included in their returns respectively.  
 Bm. & Midland Tramways, Lim. (34 Sumner Row, Bm.)—*Chr* J. Sampson  
 Forre, *Sec & GM* Wm. E. Kenway, *Engr* W. Lyster, *Holt*, C.E.; 11 m.  
 The Edginstown & Harborne Tr. Co.—  
 Blackburn (104,002). The Blackburn & Over Darwen Tramways Co. (40 Castle St.,  
 Liverpool).—*Chr* L. B. Lee, J.E.; 5.2 m, 4 g; 12 c, 8 stn ur.  
 Blackburn Corporation Tramways.—  
 Blackpool (14,448). Blackpool (Electric) Tr. Co., Lim. (Tailor Square, Blackp.)—*Sec*  
 F. Haulley; 2 m; 10 c, 7 electric m.  
 Bolton (105,378). Bolton & Suburban Tr. Co.—12.8 m; 2.6 m, 230 h.  
 Botic-cum-Linacre (27,112).  
 Bradford (183,032). Bradford Corporation Tramways (84 m) are leased to the two  
 following companies.  
 Bradford Tramways & Omnibus Co., Lim. (Northgate, Bradford).—*Chr*  
 Wm. Tuxton, *Sec* J. C. Chaplin; 23 c, 160 h, 11 stn ur.  
 Bradford & Shelf Tr. Co.—14 c, 8 stn ur.  
 Brighton (128,407). The Brighton District Tramways Co. (3 New Road, Brighton).  
*Chr* W. L. Holt, *Sec* A. M. Rose; 4.64 m, 3-6 g; 12 c, 9 stn ur.  
 Bristol (206,503). The Bristol Tramways Co., Lim. (31 Clare St., Bristol).—*Chr*  
 Wm. Butler, *GM* (Traffic) Chas. Challenger, *Sec* Geo. White, *Engr* Joseph  
 Kincaid, M.I.C.E.; 118 m; 45 c, 4 buses, 404 h.  
 Burnley (63,502). The Burnley & District Tramways Co., Lim. (57 Moorgate St.,  
 E.C.2, London).—*GM* H. Medley, *Sec* Edwd. Bellamy; 7.01 m; 12 c, 13 stn ur.  
 Cambridge (40,882). The Cambridge St. Tramways Co. (3 Alexander St., Cam.)—  
*Chr* A. P. Humphrey, M.A., *Sec* J. Chater; 3 m, 4 g; 6 c, 20 h.  
 Caermarthen (9,619). L. & L. Union Tr. Co.  
 Cardiff (85,378). Cardiff District & Penarth Harbour Tr. Co., Lim. (17 Church St.,  
 Cardiff).—*Chr* Alderman D. Jones, *Sec* D. Roberts, F.C.A.; 3.25 m; 11 c, 72 h.  
 The Cardiff St. Tramways (Bate Road, Cardiff).—Owned by the Provincial  
 Tramways Co., Lim. (7 Poultry, London).—*Sec* J. B. Glenn, *GM* W. C. Har-  
 ley; 4.5 m; 29 c, 154 h.  
 Chatham (48,806). The Chatham & Brompton Tr. Co.—1.45 m, 3 g.  
 Chester (40,322). Chester Tramways Co. (Opposite General Ry. Station, Chester).—  
*Chr* J. M. Hengier, *Sec* John Gardner, *Engr* Geo. Hopkins, C.E.; 4 m; 17 c,  
 51 h.  
 Chesterfield (12,221). Chesterfield, Brampton & Whittington Tr. Co.—1.04 m; 3 c, 5 h.  
 Colchester (28,995). Colchester Tr. Co.—2.7 m, 4 g.  
 Coventry (47,366). The Coventry & District Tramways Co. (2 East India Avenue,  
 Leadenhall St., E.C., London).—*Chr* L. Bisnop, *Sec* E. W. Layton; 5.75 m, 3-6  
 g; 6 c, 4 stn ur.  
 Croydon (78,947). The Croydon & Norwood Tramways Co. (Thornton Heath, Sur-  
 rey).—*Chr* W. J. C. Wain, *Sec & GM* W. E. C. Worrell, *Engr* Thos. Floyd, C.E.;  
 12.5 m; 14 c, 98 h.  
 Darlington (19,574). The South Staffordshire & Birmingham District Steam  
 Tramways Co., Lim. (Tramways Depot, Darlington).—*Chr* W. J. C. Wain, *Sec* H.  
 Hinchell, *GM* A. Dickinson; 34 c, 37 stn ur.  
 Derby (80,410). The Derby Tramways Co., Lim. (Commercial Bank Chambers,  
 Derby).—*Chr* W. Barfoot, J.E., *Sec* Jos. H. Richardson, *GM* W. Spawton; 6.8  
 m, 4 g; 18 c, 62 h.  
 Dewsbury (69,531). Dewsbury, Batley & Bristol Tr. Co.—4.3 m; 10 c, 9 stn ur.

**H. K. PORTER & CO., Pittsburgh, Pa.**

—BUILDERS OF—

Light Locomotives

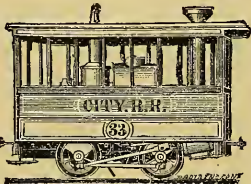

NOISELESS Street Motors

FOR— EVERY VARIETY OF SERVICE.

6 x 10, 7 x 12, 8 x 12, 9 x 14, 9½ x 14, 10 x 16, 10 x 12 x 18 Cylinders for Narrow or Wide Gauge.

FINISHED PARTS KEPT ON HAND READY FOR EARLY DELIVERY.

CATALOGUE AND PHOTOGRAPHS FURNISHED ON APPLICATION.

**The Hoefinghoff & Lutz Foundry Co.**

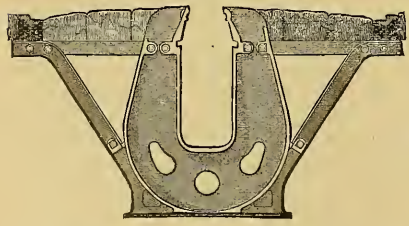

General Foundry Work, Heavy Castings and Cable Railway Work

A SPECIALTY.

Front, Lawrence and Pike Streets. Office, 154 E. Front Street, CINCINNATI.







**Erfurt** (53,372). Erfurt St. Ry. Stock Co.—Dir E. von Dalletitz; 6.21 m; 20 c, 65 h.  
**Flensburg** (1,780). Flensburg Horse Ry.—1,552 m.  
**Frankfurt** (145,000). Frankfort Tramway Co.—Dir G. Behrlinger (Frankfort-on-Main); 13,365 m; 54 c, 160 h.  
**Garitz** (53,000). Goerz Hoesck & Herrn-Schmidt; 15 m.  
**Hagen** (24,335). Hagen St. Ry. Co.—Dir Alex. von Stuelhagen; 4,968 m; 7 c, 28 h.  
**Halle** (80,000). Halle St. Ry. Co.—Dir Gater; 3,347 m; 20 c, 64 h.  
**Hamburg** (258,850). Hamburg St. Ry. Co.—Dir J. A. Guller; 62,291 m; 244 c, 913 h, 19 stn. nr.  
**Hannover-Altona** Hannover Tramway Co. of Germany.—Dir C. W. Gordon; 18,525 m; 63 c, 150 h.  
**Hannover-Vorort** St. Ry. Co.—Dir & Engr Hensinger von Waldegg; 2,173 m; 2 c, 5 h.  
**Karlsruher** (60,000). United Steam & Horse Ry. Co. of Karlsruhe, Muehlburg and Durlach; Heeslers Hoesck & Herrn-Schmidt; 18 m.  
**Kiel** (43,000). Kiel St. Ry. Co.—1,525 m.  
**Koenigsburg** (141,000). Koenigsburg Horse Ry. Co.—Dir Scheidel; 9,342 m; 76 c, 151 h.  
**Leipzig** (149,051). Leipzig Tramways Co. (Lim.)—General direction, London.—Mgr Bernhard Hille, Dir Leipzig Rendnitz; 21.9 m; 92 c, 512 h.  
**Luebeck** (51,000). Luebeck Horse Ry. Co.—Dir Max Dohr; 5,247 m; 16 c, 62 h.  
**Magdeburg** (97,529). Magdeburg St. Ry. Co.—Dir Kitzing; 10,346 m; 40 c, 175 h.  
**Magence** (90,000). Magence St. Ry. Stock Co.—Dir Fr. Schlimanski; 5,589 m; 20 c, 100 h.  
**Manheim** (68,000). Manheim Ludwigshafen Tramway.—Dir Emil Reitzschel, Manheim; 5,377 m; 17 c, 49 h.  
**Meckenburg** (42,000). Meckenburg St. Ry. Stock Co. of Rostock and Schwerin.—Dir Oscar Otto, Berlin, 4,968, 2,484 m; 17 c, 52 h.  
**Metz** (53,107). Metz Soc. Anon. des Tramway de Metz (Anonymous Asso. of Metz Tramway).—Dir C. W. Boeder; 2,749 m; 20 c, 70 h.  
**Munich** (230,023). Munich Tramway Stock Co.—Dir E. Graziadei; 33,584 m; 135 c, 320 h.  
**Nurnberg** (138,000). Nurnberg-Fuerth St. Ry. Co.—Engr & Dir Roth; 15,587 m; 46 c, 150 h.  
**Rosen** (65,000). Rosen Horse Ry. Co.—Dir Reimer; 3,639 m; 20 c, 54 h.  
**Potsdam** (83,000). Potsdam St. Ry. Co.—Dir Emil Bauer; 4,781 m; 29 c, 60 h.  
**Plymouth** (1,500). Plymouth St. Ry. Stock Co.—Aud & S. Steinhilber; 2,484 m; 5 c, 12 h.  
**Stettin** (115,000). Stettin Horse Ry. Co.—Dir Alb. Kitzing; 8,154 m; 22 c, 122 h.  
**Strasburg** (111,000). Strasburg St. Ry. Co.—Engr & Dir Alfred Noeili; 16,17 m; 96 c, 20 stn. nr.  
**Stuttgart** (117,000). Stuttgart Horse Ry. Co.—Dir George Dinkel; 6,392 m; 39 c, 82 h.  
**Fornesch** (5,000). Fornesch-Netersen Horse Ry. (City of Netersen, Holstein).—3,195 m; 4 c.  
**Wiesbaden** (56,000). Wiesbaden Horse Ry. Co.—Dir Voss; 2,40 m; 12 c, 27 h.

**AUSTRIA-HUNGARY.**

**Arad** (33,000). Arad St. Ry. Co.—Dir Ludwig Denner; 8,456 m; 14 c, 20 h.  
**Buda** (8,547). Buda-Pesth St. Ry. Co.—Engr W. Tedesco (Buda near Vienna).  
**Buda** (300,000). Buda-Pesth St. Ry. Co.—Dir Henri Jelliczek; 45,357 m; 278 c, 940 h.  
**Graz** (93,000). Graz Tramway.—Dir Jacob Markbreiter; 7 m; 30 c.  
**Lemberg** (104,000). Lemberg Tramway.—Dir Julius Schuster; 15 m; 26 c, 116 h.  
**Linze** (50,000). Linze Tramway.—Dir L. Pfl. Schindt; 7 m; 16 c, 25 h.  
**Pest** (10,000). Pest-Palota St. Ry.—2,749 m; 13 c.  
**Prague** (196,000). Prague Tramway.—Dir Constantin de Preter; 23,649 m; 85 c, 407 h.  
**Temesvar** (38,000). Temesvar St. Ry. Co.—Engr Heinrich Boeder; 6,006 m; 21 c, 69 h.  
**Trieste** (327,000). Trieste Tramway Co.—Dir J. Fausta; 59.3 m; 561 c, 1,821 h.  
**Vienna** (1,020,770). New Vienna Tramway Co.—Engr A. Pastorelli; 21 m; 66 c, 160 h.

**NETHERLANDS.**

**Amsterdam** (370,000). Amsterdam Omnibus Co.—Dir K. H. Sebodd; 12,839 m; 178 c, 600 h.  
**Arnhem** (42,000). Arnhem Tramway Co.—16 c, 62 h.  
**Dordrecht** (29,000). Dordrecht Tramway.—W. Kitzing; 3 c, 6 h.  
**Guineken-Breda** (23,000). Guineken-Breda Tramway Co.—Dir M. A. Kuytenbrover; 2,446 m; 6 c, 10 h.  
**I. Groninger** (—). I. Groninger Tramway Co.—Vandam; 1.7 m; 13 c, 39 h.  
**Groningue** (40,000). Soc Anon des Tramways de Groningue.—3,042 m; 7 c, 16 h.  
**Hague** (157,000). Hague Tramway.—Dir E. Billen; 24,219 m; 82 c, 280 h.  
**Haarlem** (37,000). Haarlem Tramway Co.—Dir J. H. Van West, Jr.; 1.1 m; 10 c, 10 h.  
**Leiden** (42,000). Leiden Tramway Co. (office, London).—Dir Fryman, s'Gravenhage; 100, 10 h.  
**Slechtsche** Tramway Co. of Utrecht; Dir W. J. Visser; 7,327 m; 14 c, 45 h.  
**Rotterdam** (152,517). Rotterdam, Hildersberg, Schieland Tramway Co.—Dir H. F. Schommers; 2,690 m; 6 c, 20 h.  
**Rotterdam Tramway Co.**—Dir H. F. Ginchart; 11,440 m, 80 c, 206 h.  
**Zwit-Drieherg** (Westerzooien) Tramway.—W. J. Visser; Utrecht; 3 c, 5 h.  
**Utrecht** (69,667). Netherlands Tramway Co. of Utrecht.—Dir S. Haubnik; 50.3 m; 24 c, 10 h.

**SWITZERLAND.**

**Basle** (62,000). Basle Tramway Co.—Promotor J. Settember; 8c, 60 h.  
**Geneva** (46,783). Comp. Gen. of Swiss Tramways; Engr T. Laval; 12,988 m; 51 c, 162 h, 1 stn nr.  
**Bortzlingen-Ried-Andon** (12,000). Tramway Co.—Engr T. Laval; 2,949 m; 7 c, 15 h.  
**Zurich** (21,199). Zurich St. Ry. Stock Co.—GM Th. Rubi; 7,415 m; 30 c, 104 h.

**BELGIUM.**

**Anvers** (—). National Tramways of Anvers.—Dir Vander Meeren.  
 Tramways of South Anvers.—Dir Galliers.  
**Brussels** (389,782). Tramways of Brussels.—Dir H. G. Michelet, Engr F. Nounenbery, Chief of technical service.  
 General Company of Railway.—Dir de Backer.  
 Company of Secondary Ry.—Dir A. Foquet, Engr A. Spee.

**FRANCE.**

**Reims** (81,328). Tramways of Reims.—Dir E. Thomas.  
**Rouen** (104,902). Rouen Tramways Co. (56 Rue Beauvoisine, Rouen).—38 c, 155 h, 7,116 shares (500 francs each) of the Compagnie des Tramways de Rouen are held by the Tramways Company of France, Limited (11 Old Jury Chambers, E. C., London).

**ITALY.**

**Brescia** (38,900). Tramways of Brescia.—Engr A. Spee (Brussels).  
**Milan** (295,543). The Lombardy Road Railway Co. Lim. (4 Cortina Building, E. C., London, Eng, and 42 via Carlo Farini, Milan); 75 kil; 456, 54 wagons.

**NORWAY.**

**Christiania** (124,155). Tramways of Christiania.—Dir M. Vogt.

**RUSSIA.**

**Kharkoff** (—). The Tramways of Kharkoff.—W. Hammeleath, See of Administration, Brussels.  
**Moscow** (—). The Tramways of Moscow and Russia.—See Mr. Hammeleath.  
**Odessa** (—). Tramways of Odessa.—Engr M. Bourson, Brussels.  
**Warsaw** (—). Dir de Backer, Brussels.

**SPAIN.**

**Madrid** (397,861). Madrid St. Tramways.—Owned by the Tramways Union Co. Lim., London.—6.5 m; 55 c, 297 h.

**ROMANIA.**

**Bucharest** (221,805). Bucharest Tramways.—Owned by the Tramways Union Co. Lim., London.—See J. E. Walker, GM G. W. Webb; 10.5 m; 42 c, 169 h.

**INDIA.**

**Calcutta** (871,504). The Calcutta Tramways Co., Lim. (11 Abchurch Lane, E. C., London, Eng.)—Chr E. C. Morgan, Sec Chas. Akers, Engr Geo. Hopkins, C.E.; Managing agent in Calcutta J. R. Maples; 19.5 m, 150 c, 662 h, 9 stn nr.

**AUSTRALIA.**

**NEW SOUTH WALES.**

**Melbourne** (250,336). The Melbourne Tr. Co.—Engr Geo. Ducans; 34 m (10 m cable road in operation).  
**Sydney** (232,133). The Sydney Cable Tr. Co.—3.5 m (cable).

**CHEAPEST HOUSE IN THE WORLD**

FOR ALL KINDS OF

**Engineers' Instruments**

—FOR THE—

**Survey of Cable and other Street Railways.**

Transits, Levels, Rods, Chains, Tapes, Plumb-bobs, Etc., a Speciality.

**Aloe's New Model Transit,**

Especially adapted for Street Railway Work.

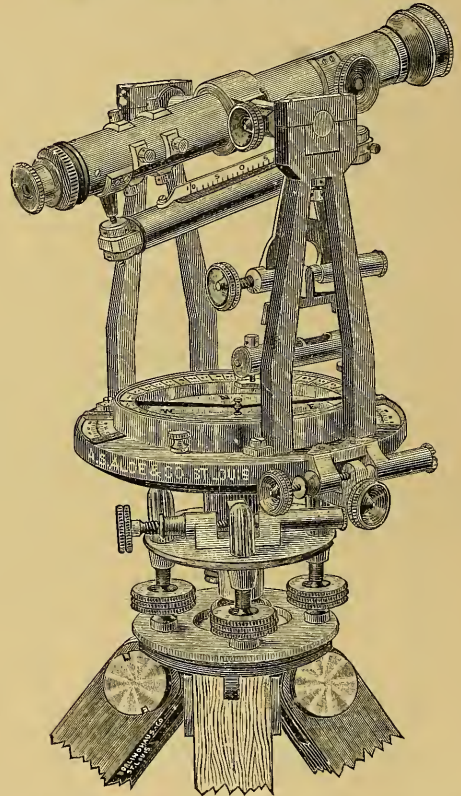

We will guarantee this instrument first-class in every respect. Send for illustrated catalogue and price list. We will make special prices to roads dealing direct.

Also, Blue Print Paper. Mathematical and Drawing Instruments, Drawing Paper, Boards, Pins, Etc. Paints, Brushes, Palettes, Etc. Curves, Pencils, India Ink, Rules, Ellipses, Engineers' Alphabets, Protractors, Compasses, Sextants, and everything for use either in the field or draughting room.

**A. S. ALOE & CO.,**

300 North 4th Street, ST. LOUIS, MO.



# TRADE DIRECTORY

CORRECTED MONTHLY.

**AMBULANCE CARS (For Horses).**  
**BROOKLYN RAILWAY SUPPLY CO. (The),** 41 Wallworth st., Brooklyn, N. Y.

**AXLES.**  
**ANDREWS, FRANK H.,** 545 W. 33rd st., New York (side brakes).

**BALTIMORE CAR WHEEL CO. (The),** Fulton Junction, Baltimore, Md. H. S. A. (Agents—) W. Meyersberg & Co., Chicago and St. Louis; W. S. Graf Baker, care of Brown, Shipley & Co., Lombard, Ill., Leontin, Ill., Chicago, Ill.

**BENIN CAR BOX CO.,** Springfield, Mass.  
**BOWLER & CO.,** Cleveland, Ohio.  
**BULL, G. C.,** Philadelphia, Pa.

**BROWNELL & WRIGHT CAR CO.,** 2300 Broadway, St. Louis, Mo.

**Cambria Iron Co.,** 218 S. Fourth st., Philadelphia; works at Johnstown, Pa. (Branches—No. 18 Wall st., New York; Mountbank Block, Chicago, Ill.)  
**Carrigan, Phipps & Co., Limited,** 32 Fifth st., Pittsburgh, Pa.

**FELTON FOUNDRY (S. M. Carpenter, proprietor),** 202 Merwin st., Cleveland, O. (Agent—Thos. C. White, 107 S. 8th st., St. Louis, Mo.)

**Griffin Wheel & Foundry Co.,** Embury st. and Blue Island ave., Chicago, Ill., and Buffalo, N. Y.

**Howard, Childs & Co.,** Hamilton Building (rooms 677 and 683) Pittsburgh, Pa.

**Laclede Car Co.,** 4500 N. Second st., St. Louis, Mo.  
**LEWIS & FOWLER MANUFACTURING CO. (The),** 205 W. 35th st., New York, N. Y.

**Meyersberg, O. W. & Co.,** 204 N. 3d st., St. Louis, Mo. (Branch—Phenix Bldg., Chicago, Ill.)

**Pennsylvania Steel & Pipe Co.,** Philadelphia. (Works at Steelton, Dauphin Co., Pa.)

**PUGH & RUSSELL, Stewart Bldg.,** New York; Phenix Bldg., Chicago, Ill.

**STEPHENSON (JOHN) COMPANY, Lim.,** 47 E. 27th st., New York. (Branch—Phenix Bldg., Chicago, Ill.)

**STREET RAILWAY SUPPLY CO.,** Cleveland, Ohio.  
**WHITNEY, A. & SONS, Philadelphia, Pa.**

**BARBED WIRE.**  
**Cambria Iron Co.,** 218 S. 4th st., Philadelphia (side axle).

**BEALINGS.**  
**ADAMS & WESTLAKE CO. (The),** 110 Ontario st., Chicago; 115 Broadway, New York.

**Ajax Metal Co. (The),** 2040 N. Dennis st., Philadelphia.  
**Brookman Brothers, Ltd.,** 100 Broad, Cleveland, O.

**ANDREWS, FRANK H.,** 545 W. 33rd st., New York (side brakes).

**BALTIMORE CAR WHEEL CO. (The),** Baltimore, Md. (side axle).

**BENIN CAR BOX CO.,** Springfield, Mass.  
**BULL (G. C.),** Philadelphia, Pa.

**BROWNELL & WRIGHT CAR CO.,** 2300 Broadway, St. Louis, Mo.

**Chapin Manufacturing Co.,** 69 Wall st., New York.  
**Danassens Bronze Co.,** Pittsburgh, Pa.

**FELTON FOUNDRY, Cleveland, O. (side axle).**  
**Greely, The E. S. & Co.,** 5 and 7 Dey st., New York.

**Keystone Smelting Co. (The),** Limited, 33d st., Pittsburgh, Pa.

**Laclede Car Co.,** 4500 N. Second st., St. Louis, Mo.  
**LEWIS & FOWLER MANUFACTURING CO. (The),** 27 to 35 Walworth st., Brooklyn, N. Y.

**MARTIN, RUFUS, & CO.,** 13 Park Row, New York (Branch—Whitna Construction and Supply Co., Wichita, Kan.)

**Meneely, Geo. K.,** & Co., West Troy, N. Y. (Branch—Atlanta, Ga.)

**Meyersberg, O. W. & Co.,** 214 N. 3d st., St. Louis, Mo. (Branch—Phenix Bldg., Chicago, Ill.)

**Miller, Chas. B.,** 310 E. 14th st., New York.  
**Phoenix Bronze Smelting Co. (The),** Limited, 512 Arch st., Philadelphia.

**Post & Company, Cincinnati, Ohio.**  
**PUGH & RUSSELL, Stewart Bldg.,** New York; Phenix Bldg., Chicago, Ill.

**STEPHENSON (JOHN) COMPANY, Lim.,** 47 E. 27th st., New York. (Branch—Phenix Bldg., Chicago, Ill.)

**Stewart & Mattson Manufacturing Co. (The),** 2042 N. 1st st., Philadelphia, Pa.

**STREET RAILWAY SUPPLY CO.,** Cleveland, Ohio.  
**Thayer P. W. & Co.,** 428 Ferry st., Milwaukee, Wis.

**Thoburn Smelting Works,** 760 S. Broad st., Philadelphia.  
**White, Edward C.,** 534 W. 33rd st., New York.

**BELLS.**  
**MARTIN, RUFUS, & CO.,** 13 Park Row, New York Post & Co., Cincinnati, O.

**Star Bell Co.,** Eschschon, Mass.  
**VauDeuz & THIE,** 102 and 104 E. Second st., Cincinnati, O.

**BEELING.**  
**Page Beeling Co.,** Concord, N. H. (Branches—19 Feid-st. Chicago; 17 and 19 Liberty, New York; 151 Broadway, St. Chicago; 8th and St. Charles st., St. Louis, Mo.; 1207 W. 12th St., Kansas City, Mo.)

**Schuchert Beeling Co.,** Chicago; (Branches—Curtis & Co. Mfg. Co., 60 W. Monroe st., Chicago; Jas. Garnett, Philadelphia; Frank Petree, Boston, Mass.)

**BENDING MACHINES.**  
**Ayres, Abraham,** 502 to 518 W. 45th st., New York.  
**BROOKLYN RAILWAY SUPPLY CO. (The),** 41 Wallworth st., Brooklyn, N. Y.

**Chapin Steel Casting Co.,** 107 Liberty st., Philadelphia. (Works—Clement, Pa.)

**Craig Wm. P.,** 95 Liberty st., New York.  
**Greely (The E. S. & Co.),** 5 and 7 Dey st., New York.

**Harris T. Wm. & Co.,** 2 Nassau st. (room 17), New York.  
**Howard, Childs & Co.,** Hamilton Building, Pittsburgh, Pa. & FOWLER MFG. CO. (The), 27 to 35 Walworth st., Brooklyn, N. Y.

**PUGH & RUSSELL, Stewart Bldg.,** New York; Phenix Bldg., Chicago, Ill.  
**Wm. Wharton, Jr., & Co. (Incorporated),** 25th st. and Washington ave., Philadelphia, Pa.

**ROTS.**  
**Daytons, M.,** Cincinnati, O.

**BRACES.**  
**JOHNSON STEEL STREET RAIL CO. (The),** Johnstown, Pa. (side axle Yokes).

**DUNN, L. K.,** Seely Northern, Central Ry. Co., St. Louis, Mo.

**BRAKE CHAINS.**  
**ROEHLING'S SONS CO., JOHN A.,** Treuton, N. J.; 173 and 175 Philadelphia, N. Y.; 173 and 175 Lake st., Chicago; 14 Drum st., San Francisco, Cal.)

**BRAKE HANDLES.**  
**Brill (G. C.),** Philadelphia, Pa.

**MARTIN, RUFUS, & CO.,** 13 Park Row, New York.  
**STEPHENSON (JOHN) COMPANY, Lim.,** 47 E. 27th st., New York. (Branch—Phenix Bldg., Chicago, Ill.)

**BRAKE RODS.**  
**Brill (G. C.),** Philadelphia, Pa.

**BROWNELL & WRIGHT CAR CO.,** 2300 Broadway, St. Louis, Mo.

**Howard, Childs & Co.,** Hamilton Building, Pittsburgh.  
**Laclede Car Co.,** 4500 N. Second st., St. Louis, Mo.

**LEWIS & FOWLER MFG. CO. (The),** 27 to 35 Walworth st., Brooklyn, N. Y.

**MARTIN, RUFUS, & CO.,** 13 Park Row, New York.  
**PUGH & RUSSELL, Stewart Bldg.,** New York; Phenix Bldg., Chicago, Ill.

**STEPHENSON (JOHN) COMPANY, Limited,** 47 E. 27th st., New York. (Branch—Phenix Bldg., Chicago, Ill.)

**Brill (G. C.),** Philadelphia, Pa.

**BROWNELL & WRIGHT CAR CO.,** 2300 Broadway, St. Louis, Mo.

**Greely, The E. S. & Co. & 5 and 7 Dey st.,** New York.  
**Howard, Childs & Co.,** Hamilton Building, Pittsburgh.

**Laclede Car Co.,** 4500 N. Second st., St. Louis, Mo.  
**LEWIS & FOWLER MFG. CO. (The),** 27 to 35 Walworth st., Brooklyn, N. Y.

**MARTIN, RUFUS, & CO.,** 13 Park Row, New York.  
**PUGH & RUSSELL, Stewart Bldg.,** New York; Phenix Bldg., Chicago, Ill.

**STEPHENSON (JOHN) COMPANY, Limited,** 47 E. 27th st., New York. (Branch—Phenix Bldg., Chicago, Ill.)

**Wilson, Mortimer M.,** (Agent), New York, N. Y.

**BRAKE SHOES.**  
**ANDREWS, FRANK H.,** 545 W. 33rd st., New York (side brakes).

**Ayres, Abraham,** 502 to 518 W. 45th st., New York.  
**BALTIMORE CAR WHEEL CO. (The),** Baltimore, Md. (side axle).

**Brill (G. C.),** Philadelphia, Pa.

**BROWNELL & WRIGHT CAR CO.,** 2300 Broadway, St. Louis, Mo.

**Chester Steel Castings Co.,** 407 Liberty st., Philadelphia. (Works—Ohio (side axle).

**Greely, The E. S. & Co. & 5 and 7 Dey st.,** New York.  
**Griffin, Thos. F.,** & Sons, Buffalo, N. Y.

**Howard, Childs & Co.,** Hamilton Building, Philadelphia.  
**Laclede Car Co.,** 4500 N. Second st., St. Louis, Mo.

**LEWIS & FOWLER MFG. CO. (The),** 27 to 35 Walworth st., Brooklyn, N. Y.

**MARTIN, RUFUS, & CO.,** 13 Park Row, New York.  
**PUGH & RUSSELL, Stewart Bldg.,** New York; Phenix Bldg., Chicago, Ill.

**St. Thomas Car Wheel Co.,** St. Thomas, Ont., Canada.  
**STEPHENSON (JOHN) COMPANY, Lim.,** New York.

**STREET RAILWAY SUPPLY CO.,** Cleveland, Ohio.  
**Yuleanized Fibre Co.,** Wilmington, Del. (New York office—145 1/2 st., Washington ave., Philadelphia, Pa.)

**Whiting Mfg. Co.,** Cedar Rapids, Iowa.  
**WHITNEY, A. & SONS, Philadelphia, Pa.**

**BROOMS (Bass and Eattan).**  
**BROOKLYN RAILWAY SUPPLY CO. (The),** 41 Wallworth st., Brooklyn, N. Y.

**MARTIN, RUFUS, & CO.,** 13 Park Row, New York.  
**Phenix Steel Wire Form and Brush Co.,** 199 E. Randolph st., Chicago, Ill.

**BRUSHES (Paint).**  
**COFFIN, DEVOE & CO.,** 176 Randolph st., Chicago, Ill.

**CABLE CASTINGS.**  
**HORACE A. KEEFER CO.,** Cincinnati, O.

**LANE & BODLEY CO. (The),** 267 to 283 Water st., Cincinnati, Ohio.

**St. Louis Malleable Iron Works, St. Louis, Mo.**

**CABLE CONDUITS.**  
**WAY FOUNDRY CO. (The),** 23rd and Wood sts., Philadelphia, Pa.

**CABLE RAILWAY PATENTS.**  
**Cable Railway Co. (The),** 329 Market st., San Francisco. National Cable Railway Co. (The), 110 Nassau st. (room 25), New York. Owners of all the original and fundamental United States patents (embracing the Hall's tie system covering the construction and operation of Cable Rails) for all that portion of the United States lying east of the 106th degree of longitude.

**Patent Cable Tramways Corporation, Limited,** 3 Victoria Mansions, Victoria st., S.W. London, Eng.

**Rasmussen Cable Co.,** room 606 First National Bank Bldg., Philadelphia, Pa.

**CABLE RAILWAY PLANTS.**  
**Hooven, Owens & Reutscher Co. (The),** Hamilton, Ohio.  
**LANE & BODLEY CO. (The),** 267 to 283 Water st., Cincinnati, Ohio.

**POOLE & HUNT, Baltimore, Md. (side Grips).**  
**Walker Manuf. Co.,** Cleveland, O.

**CABLE RY. SWITCHES (Automatic).**  
**Wm. Wharton, Jr., & Co. (Incorporated),** 25th st. and Washington ave., Philadelphia, Pa.

**CABLE RAILWAY WORK.**  
**WAY FOUNDRY CO. (The),** 23rd and Wood sts., Philadelphia, Pa.

**CABLES.**  
**BRODERICK & BASCOM ROPE CO.,** 704 N. Main st., St. Louis.

**Bullivant & Co.,** 72 Mark Lane, London, E. C.  
**California Wire Works,** 329 Market st., San Francisco, Cal.

**Greely, The E. S. & Co.,** 5 and 7 Dey st., New York.  
**Haines Bros.,** 55 Broadway, New York.

**HAZARD MFG. CO.,** Wilkes Barre, Pa. (Branches—C. J. Commercial st., Boston, Mass.; 25 Sante Gay St., Baltimore, Md.; 25 S. M. st., St. Louis, Mo.; Utah; 218 Lake st., Chicago, Ill.; 5 Sixth ave., Pittsburgh, Pa.; 21 Fremont st., San Francisco, Cal.; 703 Broadway, N. Y. City; 138 S. Delaware ave., Philadelphia, Pa.; 87 Liberty st., New York; Kansas City, Mo.; St. Louis, Mo.; Cincinnati, O.)

**Howard, Childs & Co.,** Hamilton Building, Pittsburgh.  
**JOHNSON, TOM J.,** Philadelphia, Pa.

**Post & Company, Cincinnati, Ohio.**  
**ROEHLING'S SONS CO., JOHN A.,** Treuton, N. J.; 173 and 175 Philadelphia, N. Y.; 173 and 175 Lake st., Chicago; 14 Drum st., San Francisco, Cal.)

**WASHINGTON A MOKEN MANUFACTURING CO.,** Worcester, Mass. (Warehouses—16 1/2 st., New York, 107 and 109 Lake st., Chicago.)

**CABLE SHEETS.**  
**HOEHNHOFF & LAWE, Cincinnati, O.**

**St. Louis Malleable Iron Works, St. Louis, Mo.**  
**WAY FOUNDRY CO. (The),** 23rd and Wood sts., Philadelphia, Pa.

**CABLE YOKES.**  
**BALTIMORE CAR WHEEL CO. (The),** Baltimore, Md. (side axle).

**Greely, The E. S. & Co. & 5 and 7 Dey st.,** New York.  
**HOEHNHOFF & LAWE, Cincinnati, O.**

**HORACE A. KEEFER CO.,** Cincinnati, O.  
**JOHNSON STEEL STREET RAIL CO. (The),** Johnstown, Pa. (Branches—Cotton Exchange Building, New Orleans; Phenix Building, Chicago; Bank of Commerce Building, St. Louis, Mo.; 6 Oliver st., Boston; Stewart Building, New York; Johnston Building, Cincinnati; 252 W. Main st., Louisville, Ky. Metallic Street Railway Supply Co., 27 State st., Albany. (Agent—F. L. K. H. ANDREWS, 545 W. 33rd st., St. Louis, Mo.)

**Wm. Wharton, Jr., & Co. (Incorporated),** 25th st. and Washington ave., Philadelphia, Pa.

**CAR HUBS.**  
**Brill (G. C.),** Philadelphia, Pa.

**BROWNELL & WRIGHT CAR CO.,** 2300 Broadway, St. Louis, Mo.

**Dick, Kerr Co.,** 101 Leadenhall st., E. C. London. (Works—Britannia Engineering Works, Kilmarnock N. J.)

**Engle, Gougeon & Car Works, Limited,** Loughborough, Eng. (London office—11 Coleman st., E. C.)

**Feigel Car Co. (The),** 108 Wall st., New York.  
**Haines Bros.,** 55 Broadway, New York.

**James (J. M.) Son, West Troy, N. Y.**

**KULMANN CAR CO.,** 490 St. Clair st., Cleveland, O.  
**Laclede Car Co.,** 4500 N. Second st., St. Louis, Mo.

**Lancaster Wagon Co. (The),** Limited, Lancaster. (London office—1 Victoria st., Westminster, S. W.)  
**Metropolitan Carriage and Wagon Works, Birmingham, England.**

**PUGH & RUSSELL, Stewart Bldg.,** New York; Phenix Bldg., Chicago, Ill.

**PULLMAN'S PALACE CAR CO. (The),** Pullman, Ill.; Detroit, Mich.

**Roussin & Hie, Waterloo, Iowa.**  
**St. Louis Car Co. (The),** 3023 Broadway, St. Louis, Mo.

**Starbuck Car and Wagon Co. (The),** Limited, Birkenhead. (London office—7 W. Winchester st., London, E. C.)

**STEPHENSON (JOHN) COMPANY, Limited,** 47 E. 27th st., New York. (Branch—Phenix Bldg., Chicago, Ill.)

**CAR (Electric) BUILDERS.**  
**Glant's Gauseway Electric Tramway (W. A. Traill, Engineer),** Co. Antrim, Ireland.

**CAR CASTINGS.**  
**ADAMS & WESTLAKE CO. (The),** 110 Ontario st., Chicago, Ill. (Branch—115 Broadway, New York.)

**ANDREWS, FRANK H.,** 545 W. 33rd st., New York (side brakes).

**Askham Bros. & Wilson, Limited,** Sheffield, England.  
**Ayres, Abraham,** 502 to 518 W. 45th st., New York.

**BALTIMORE CAR WHEEL CO. (The),** Baltimore, Md. (side axle).

**BROWNELL & WRIGHT CAR CO.,** 2300 Broadway, St. Louis, Mo.

**Chester Steel Castings Co.,** 407 Liberty st., Philadelphia. (Works—Ohio (side axle).

**Craig Wm. P.,** 95 Liberty st., New York.

**FELTON FOUNDRY, Cleveland, O. (side axle).**  
**Howard, Childs & Co.,** Hamilton Building, Pittsburgh.

**Kanisher, Chas. & Co.,** 305 Canal st., Chicago, Ill.  
**Keystone Smelting Co. (The),** Limited, 33rd st., Pittsburgh, Pa.

**Laclede Car Co.,** 4500 N. Second st., St. Louis, Mo.  
**LEWIS & FOWLER MFG. CO. (The),** 27 to 35 Walworth st., Brooklyn, N. Y.

**MARTIN, RUFUS, & CO.,** 13 Park Row, New York.  
**Post & Company, Cincinnati, Ohio.**

**PUGH & RUSSELL, Stewart Bldg.,** New York; Phenix Bldg., Chicago, Ill.

**St. Thomas Car Wheel Co.,** St. Thomas, Ont., Canada.  
**SNEAD & BIRD, Louisville, Ky.**

**STREET RAILWAY SUPPLY CO.,** Cleveland, Ohio.  
**Wm. Wharton, Jr., & Co. (Incorporated),** 25th st. and Washington ave., Philadelphia, Pa.

**WHITING Mfg. Co.,** Cedar Rapids, Ia.  
**WHITNEY, A. & SONS, Philadelphia, Pa.**

**CAR CELLING.**  
**ADAMS & WESTLAKE CO. (The),** 110 Ontario st., Chicago, Ill. (Branch—115 Broadway, New York.)

**Brill (G. C.),** Philadelphia, Pa.

**BROWNELL & WRIGHT CAR CO.,** 2300 Broadway, St. Louis, Mo.

**Dayton Mfg. Co. (The),** Dayton, Ohio.  
**Frost & Peterson, New York.**

**GARDNER & CO. (The),** 42nd st., New York. (Factory—100 to 657 W. 48th st., New York.)

**Greely, The E. S. & Co.,** 5 and 7 Dey st., New York.  
**KULMANN CAR CO.,** 490 St. Clair st., Cleveland, O.

**Laclede Car Co.,** 4500 N. Second st., St. Louis, Mo.  
**PUGH & RUSSELL, Stewart Bldg.,** New York; Phenix Bldg., Chicago, Ill.  
**Porter & Huntington Co.,** Lim., 60 Shoe Lane, London.

**CAR COUPLERS.**  
**Sargent, W. W.,** Fitchburg, Mass.

**CAR HEATER FITTINGS (Hose, Etc.).**  
**Gold, Edward E.,** & Co., ne. cor. Frankfort and Chiff sts., New York.

**Greely, The E. S. & Co.,** 5 and 7 Dey st., New York.

**CAR HEATER.**  
**ADAMS & WESTLAKE CO. (The),** 110 Ontario st., Chicago, Ill. (Branch—115 Broadway, New York.)

**Brill (G. C.),** Philadelphia, Pa.

**CLINE MFG. CO.,** 277 and 279 S. Canal st., Chicago.  
**Clute, Geo. M.,** West Troy, N. Y.

**Gold, Edward E.,** & Co., ne. cor. Frankfort and Chiff sts., New York.

**Greely, E. S. & Co.,** 5 and 7 Dey st., New York.  
**Laclede Car Co.,** 4500 N. Second st., St. Louis, Mo.

**LEWIS & FOWLER MFG. CO. (The),** 27 to 35 Walworth st., Brooklyn, N. Y.



MARTIN, RUFUS, & CO., 13 Park Row, New York.  
 Missouri & Kansas Port Stone and Fuel Co., 219 and 221  
 Market st., St. Louis, Mo.  
 Post & Company, Cincinnati, Ohio.  
 PUGH & RUSSELL, Stewart Bldg., New York; Phenix  
 Bldg., Chicago, Ill.  
 STEPHENSON (JOHN) COMPANY, Limited, 47 E. 27th  
 st., New York. (Branch—Phenix Bldg., Chicago.)  
 STREET RAILWAY SUPPLY CO., Cleveland, Ohio.

**CAR LAMPS.**  
 ADAMS & WESTLAKE CO. (The), 110 Ontario st.,  
 Chicago; 115 Broadway, New York.  
 Brill (J. G.) Co., Philadelphia.  
 BROWNELL & WIGHT CAR CO. 23 Broadway, St.  
 Louis, Mo.  
 Clute, Geo. M., West Troy, N. Y.  
 Dayton Mfg. Co. (The), Dayton, Ohio.  
 Greeley, The E. S., & Co., 5 and 7 Day st., New York.  
 Laclede Car Co., 4500 N. Second st., St. Louis, Mo.  
 LEWIS & FOWLER MFG. CO. (The), 27 to 35 Wal-  
 worth st., Brooklyn, N. Y.  
 MARTIN, RUFUS, & CO., 13 Park Row, New York.  
 Miller, Chas. B., 310 E. 14th st., New York.  
 Post & Company, Cincinnati, Ohio.  
 PUGH & RUSSELL, Stewart Bldg., New York; Phenix  
 Bldg., Chicago, Ill.

STEPHENSON (JOHN) COMPANY, Limited, 47 E. 27th  
 st., New York. (Branch—Phenix Bldg., Chicago.)  
 SMITH, JOSEPHINE D., 350 Pearl st., New York.

**CAR MORTISERS.**  
 LANE & HODLEY CO. (The), 287 to 283 Water st.,  
 Cincinnati, Ohio.

**CARS (Sand and Salt).**  
 BROOKLYN RAILWAY SUPPLY CO. (The), 44 Wal-  
 worth st., Brooklyn, N. Y.

**CAR SASH.**  
 Ayers' Patent Sash Holder Co., 242 Stewart Bldg., New  
 York.  
 Brill (J. G.) Co., Philadelphia.  
 BROWNELL & WIGHT CAR CO., 2300 Broadway, St.  
 Louis, Mo.

Dayton Mfg. Co. (The), Dayton, Ohio.  
 Greeley, The E. S., & Co., 5 and 7 Day st., New York.  
 KUHLMANN CAR CO., 490 St. Clair st., Cleveland, O.  
 Laclede Car Co., 4500 N. Second st., St. Louis, Mo.  
 MARTIN, RUFUS, & CO., 13 Park Row, New York.  
 PUGH & RUSSELL, Stewart Bldg., New York; Phenix  
 Bldg., Chicago, Ill.  
 STEPHENSON (JOHN) COMPANY, Limited, 47 E. 27th  
 st., New York. (Branch—Phenix Bldg., Chicago.)

**CAR SEAS.**  
 ADAMS & WESTLAKE CO. (The), 110 Ontario st.,  
 Chicago; 115 Broadway, New York.

Brill (J. G.) Co., Philadelphia.  
 BROWNELL & WIGHT CAR CO., 2300 Broadway, St.  
 Louis, Mo.  
 Dayton Mfg. Co. (The), Dayton, Ohio.  
 Frost & Peterson, 161 W. 18th st., New York.  
 Gardner & Co., 643 to 657 W. 48th st., New York.  
 Greeley, The E. S., & Co., 5 and 7 Day st., New York.  
 Hale & Kilburn Mfg. Co. (The), 43 and 50 N. 6th st.,  
 Philadelphia.

HARFORD OVEN WIRE MATTRESS CO. (The),  
 postoffice box 383, Hartford, Conn.  
 KUHLMANN CAR CO., 490 St. Clair st., Cleveland, O.  
 Laclede Car Co., 4500 N. Second st., St. Louis, Mo.  
 MARTIN, RUFUS, & CO., 13 Park Row, New York.  
 Post & Company, Cincinnati, Ohio.  
 PUGH & RUSSELL, Stewart Bldg., New York; Phenix  
 Bldg., Chicago, Ill.  
 Purly & Huntington Co., Limited, 60 Shoe Lane, E. C.,  
 London.

STEPHENSON (JOHN) COMPANY, Limited, 47 E. 27th  
 st., New York. (Branch—Phenix Bldg., Chicago.)  
 Wasefield Battran Co., Boston, Mass. (Branches—444  
 Market st., San Francisco; 144 and 146 Walnut st.,  
 Chicago; 924 Broadway, and 8 Park pl., New York.)

**CARS (Second Hand).**  
 Brill (J. G.) Co., Philadelphia.  
 BROOKLYN RAILWAY SUPPLY CO. (The), 44 Wal-  
 worth st., Brooklyn, N. Y.

BROWNELL & WIGHT CAR CO., 2300 Broadway, St.  
 Louis, Mo.  
 Greeley, The E. S., & Co., 5 and 7 Day st., New York.  
 Haines Bros., 55 Broadway, New York.  
 Humphreys & Sayce, 1 Broadway, New York.  
 MARTIN, RUFUS, & CO., 13 Park Row, New York.  
 PUGH & RUSSELL, Stewart Bldg., New York; Phenix  
 Bldg., Chicago, Ill.

**CAR SEEDS AND STAPLES.**  
 Evans, H. D., Sunnyside Works, Horsey Rise, N. Lon-  
 don.

**CAR SIGNALS.**  
 Brill (J. G.) Co., Philadelphia.  
 MARTIN, RUFUS, & CO., 13 Park Row, New York.

**CAR SIGNS.**  
 Brill (J. G.) Co., Philadelphia.  
 MARTIN, RUFUS, & CO., 13 Park Row, New York.

**CAR SPRINGS.**  
 ANDREWS, FRANK H., 545 W. 33rd st., New York  
 (vide Brakes).  
 BALTIMORE CAR WHEEL CO. (The), Baltimore, Md.  
 (vide Axles).  
 BEMIS CAR BOX CO., Springfield, Mass.  
 Brill (J. G.) Co., Philadelphia.  
 BROWNELL & WIGHT CAR CO., 2300 Broadway, St.  
 Louis, Mo.  
 Clute & Righter, Oswego, N. Y.  
 Diamond Street Car Spring Co., 8th and Railroad av.,  
 Wilmington, Del.

French, A. A., Car Spring Co., Pittsburg, Pa.  
 Greeley, The E. S., & Co., 5 and 7 Day st., New York.  
 Howard, Childs & Co., Hamilton Bldg., Pittsburg, Pa.  
 LEWIS & FOWLER MFG. CO. (The), 27 to 35 Wal-  
 worth st., Brooklyn, N. Y.

MARTIN, RUFUS, & CO., 13 Park Row, New York.  
 Peckering Springs Co., Limited, Philadelphia, Pa.  
 Post & Company, Cincinnati, Ohio.  
 PUGH & RUSSELL, Stewart Bldg., New York; Phenix  
 Bldg., Chicago, Ill.

STEPHENSON (JOHN) COMPANY, Limited, 47 E. 27th  
 st., New York. (Branch—Phenix Bldg., Chicago.)  
 STREET RAILWAY SUPPLY CO., Cleveland, Ohio.  
 VOSK, RICHARD, 13 Barclay st., New York. (Branches  
 —104 N. 3rd st., St. Louis; 117 Adams Express Bldg.,  
 Chicago, Ill.)

**CAR STARTERS.**  
 BAKER, W. S. GRAFF, care Brown, Shipley & Co.,  
 Lombury E. C., London, Eng.; and postoffice box  
 176, Baltimore, Md.

**CAR STOOLES.**  
 Haddox, W. O., Louisville, Ky.

**CAR TRIMMINGS.**  
 ADAMS & WESTLAKE CO. (The), 110 Ontario st.,  
 Chicago; 115 Broadway, New York.  
 Brill (J. G.) Co., Philadelphia.  
 BROWNELL & WIGHT CAR CO., 2300 Broadway, St.  
 Louis, Mo.

Dayton Mfg. Co. (The), Dayton, Ohio.  
 Greeley, The E. S., & Co., 5 and 7 Day st., New York.  
 LEWIS & FOWLER MFG. CO. (The), 27 to 35 Wal-  
 worth st., Brooklyn, N. Y.  
 MARTIN, RUFUS, & CO., 13 Park Row, New York.  
 Miller, Chas. B., 310 E. 14th st., New York.  
 Post & Company, Cincinnati, Ohio.  
 CHERRY, J. J., 120 Broadway, New York; Phenix  
 Bldg., Chicago, Ill.

STEPHENSON (JOHN) COMPANY, Limited, 47 E. 27th  
 st., New York. (Branch—Phenix Bldg., Chicago.)  
 SMITH, JOSEPHINE D., 350 Pearl st., New York.  
 Stewart & Matson Mfg. Co. (The), 2043 N. 10th st.,  
 Philadelphia.  
 White Edw. C., 531 W. 33rd st., New York.

**CAR WHEELS.**  
 ANDREWS, FRANK H., 545 W. 33rd st., New York  
 (vide Brakes).  
 BAKER W. S. GRAFF, care Brown, Shipley & Co.,  
 London (vide Car Starters).  
 BALTIMORE CAR WHEEL CO. (The), Baltimore, Md.  
 U. S. A. Agents—O. W. Meyensberg & Co., Chicago  
 and St. Louis; W. S. Graf Baker, care of Brown,  
 Shipley & Co., Lombury, London, E. C., England.

BEMIS CAR BOX CO., Springfield, Mass.  
 BOHLE & Co., Cleveland, Ohio.  
 Brill (J. G.) Co., Philadelphia.  
 BROWNELL & WIGHT CAR CO., 2300 Broadway,  
 St. Louis, Mo.  
 Chester Steel Castings Co., 407 Library st., Philadelphia.  
 FULTON FOUNDRY, Cleveland, O. (vide Axles).  
 Griffin, Thos. E., & Sons, Brooklyn, N. Y.  
 Griffin Wheel and Foundry Co., Robey st. and Blue  
 Island av., Chicago, Ill.

HAINES' Steel Foundry Co., Aftercliffe, Sheffield, Eng.  
 HORACE A. KEEFER CO. (The), Kansas City, Mo.  
 Howard, Childs & Co., Hamilton Bldg., Pittsburg, Pa.  
 Kuehnle Car Wheel Co., Chicago, Ill.  
 Laclede Car Co., 4500 N. Second st., St. Louis, Mo.  
 LEWIS & FOWLER MFG. CO. (The), 27 to 35 Wal-  
 worth st., Brooklyn, N. Y.

MARTIN, RUFUS, & CO., 13 Park Row, New York.  
 Meyersburg, O. W., & Co., 204 N. 3d st., St. Louis, Mo.  
 Mitchell, Phenix Bldg., Chicago, Ill.  
 Miller & Co., London Road Foundry, Edinburgh, Scot.  
 Peckham Car Wheel Co. (The), Syracuse, N. Y.  
 PUGH & RUSSELL, Stewart Bldg., New York; Phenix  
 Bldg., Chicago, Ill.

STEPHENSON (JOHN) COMPANY, Limited, 47 E. 27th  
 st., New York. (Branch—Phenix Bldg., Chicago.)  
 ST. THOMAS CAR WHEEL CO., St. Thomas, Ont., Canada.  
 STREET RAILWAY SUPPLY CO., Cleveland, Ohio.  
 WILHELM, A., & SOHLMY, Philadelphia, Pa.

**CEMENTES (For Cable Roads).**  
 Empire Warehouse Co., 210 Market st., Chicago, Ill.

**CHAIRS.**  
 JOHNSON STEEL STREET RAIL CO. (The), Johns-  
 town, Pa. (vide Cable Yokes).  
 Wilsons, Pease & Co., Middleborough-on-Tees, Eng-  
 land.

**CHANGE BELTS.**  
 MARTIN, RUFUS, & CO., 13 Park Row, New York.

**CHANGE RECEIPTS.**  
 MASSON, J. H., Agent for Slawson's Patents,  
 365 Avenue A, New York.  
 WALES MANUFACTURING CO., 76 and 78 E. Water  
 st., Syracuse, N. Y.  
 Whiting, T. J., 7a South Place, Finsbury, London.

**CHANNEL PLATES.**  
 ANDREWS, FRANK H., 545 W. 33rd st., New York  
 (vide Brakes).  
 Ayres, Abraham, 620 to 518 W. 45th st., New York.  
 Critch, Wm. F., 95 Liberty st., New York.  
 HORACE A. KEEFER CO. (The), Kansas City, Mo.  
 Howard, Childs & Co., Hamilton Bldg., Pittsburg, Pa.  
 JOHNSON STEEL STREET RAIL CO. (The), Johns-  
 town, Pa. (vide Cable Yokes).  
 LEWIS & FOWLER MFG. CO. (The), 27 to 35 Wal-  
 worth st., Brooklyn, N. Y.

Meyersburg, O. W., & Co., 204 N. 3d st., St. Louis, Mo.  
 (Branch—Phenix Bldg., Chicago, Ill.)  
 PUGH & RUSSELL, Stewart Bldg., New York; Phenix  
 Bldg., Chicago, Ill.  
 Wm. Wharton, Jr., & Co. (Incorporated), 25th st. and  
 Washington av., Philadelphia, Pa.

**CHICKENYS, BULKERS & WICKS.**  
 ADAMS & WESTLAKE CO. (The), 110 Ontario st.,  
 Chicago; 115 Broadway, New York.  
 Clute, Geo. M., West Troy, N. Y.

**CLUTCH AXLES.**  
 BALTIMORE CAR WHEEL CO. (The), Baltimore, Md.  
 (vide Car Wheels).  
 Empire Axle Mfg. Co., 32 Nassau st., New York.

**COILS.**  
 COFFIN, DEVOE & CO., 176 Randolph st., Chicago, Ill.  
 Sherwin-Williams Co., 707, 100 Canal st., Cleveland,  
 O. (Branches—211 Jackson st., Chicago, Ill.; 178  
 Fulton st., New York.)

**CONCRETE MIXERS.**  
 CALDWELL, H. W., 133 W. Washington st., Chicago.  
 Kaestner Gas. & Co., 308 S. Canal st., Chicago, Ill.

**CONNECTING TRACKS.**  
 JOHNSON STEEL STREET RAIL CO. (The), Johns-  
 town, Pa. (vide Cable Yokes).

**CONTRACTORS AND BUILDERS.**  
 ANDREWS, FRANK H., 545 W. 33rd st., New York  
 (vide Brakes).  
 BAKER W. S. GRAFF, care Brown, Shipley & Co.,  
 London (vide Car Starters).  
 Chicago Electric & Ice Co. (Geo. W. Mansfield, Spt.  
 and electrician), 1st National Bank Building, Cleve-  
 land, Ohio.  
 Conway, W. E., 487 Monroe st., Brooklyn, N. Y.  
 Critch Wm. F., 95 Liberty st., New York.  
 Haines Bros., 55 Broadway, New York.  
 HATHAWAY & BOBISON, 14 Case Bldg., Cleveland, O.  
 HORACE A. KEEFER CO. (The), Kansas City, Mo.  
 Howard, Childs & Co., Hamilton Bldg., Pittsburg, Pa.  
 LEWIS & FOWLER MFG. CO. (The), 27 to 35 Wal-  
 worth st., Brooklyn, N. Y.

Nettel & Co., 1 Liberty st., New York.  
 New York Railway Supply Co., 42 Wall st., New York.  
 Raymond, James, 45 Broadway, New York.  
 WICHITA Construction and Supply Co. (The), Wichita,  
 Kans.

Wilkes & Co., 17 Bishop's Gate, E. C., London.  
 Wm. Wharton, Jr., & Co. (Incorporated), 25th st. and  
 Washington av., Philadelphia, Pa.  
 Wright Construction Co., Phenix Bldg., Chicago.  
 Wright, Messengers, & Co., St. Louis, Mo.

**CONSTRUCTION CARS.**  
 BROOKLYN RAILWAY SUPPLY CO. (The), 44 Wal-  
 worth st., Brooklyn, N. Y.

**CROSSINGS.**  
 ANDREWS, FRANK H., 545 W. 33rd st., New York  
 (vide Brakes).  
 BALTIMORE CAR WHEEL CO. (The), Baltimore, Md.  
 (vide Car Wheels).  
 Chester Steel Castings Co., 407 Library st., Philadelphia.  
 Critch Wm. F., 95 Liberty st., New York.  
 FULTON FOUNDRY, Cleveland, O. (vide Axles).  
 Greeley, The E. S., & Co., 5 and 7 Day st., New York.  
 HORACE A. KEEFER CO. (The), Kansas City, Mo.  
 Howard, Childs & Co., Hamilton Bldg., Pittsburg,  
 Pa.

JOHNSON STEEL STREET RAIL CO. (The), Johns-  
 town, Pa. (vide Cable Yokes).  
 Johnston R. E., Frog & Switch Co., Chester, Pa.  
 LEWIS & FOWLER MFG. CO. (The), 27 to 35 Wal-  
 worth st., Brooklyn, N. Y.  
 Meyersburg, O. W., & Co., 204 N. 3d st., St. Louis, Mo.  
 (Branch—Phenix Bldg., Chicago, Ill.)  
 PENNY FOUNDRY, Cleveland, O. (vide Axles).  
 PUGH & RUSSELL, Stewart Bldg., New York; Phenix  
 Bldg., Chicago, Ill.

SNEYD & HERR, Louisville, Ky.  
 WILHELM, A. & SONS, Philadelphia, Pa.  
 Wm. Wharton, Jr., & Co. (Incorporated), 25th st. and  
 Washington av., Philadelphia, Pa.

**CROSSINGS (Cable and Electric Ity.)**  
 Wm. Wharton, Jr., & Co. (Incorporated), 25th st. and  
 Washington av., Philadelphia, Pa.

**CURVES.**  
 WAX FOUNDRY CO. (The), 23d and Wood sts., Phila-  
 delphia, Pa.

**DOOR STOPS.**  
 ADAMS & WESTLAKE CO. (The), 110 Ontario st.,  
 Chicago; 115 Broadway, New York.  
 Brill (J. G.) Co., Philadelphia, Pa.  
 BROWNELL & WIGHT CAR CO. 2300 Broadway,  
 St. Louis, Mo.

Greeley, The E. S., & Co., 5 and 7 Day st., New York.  
 Haycox Door Fastener Co., 1155 Euclid av., Cleveland,  
 Ohio.  
 Miller, Chas. B., 310 E. 14th st., New York.  
 Post & Company, Cincinnati, Ohio.  
 PUGH & RUSSELL, Stewart Bldg., New York; Phenix  
 Bldg., Chicago, Ill.

**DRAW HEADS.**  
 Brill (J. G.) Co., Philadelphia, Pa.

STEPHENSON (JOHN) COMPANY, Limited, 47 E. 27th  
 st., New York. (Branch—Phenix Bldg., Chicago.)  
**DRIVING MACHINERY.**  
 HOWARD, CHILD & CO. (The), Kansas City, Mo.  
 LANE & BOULBY CO. (The), 267-283 Water st., Cin-  
 cinnati, Ohio.  
 PUELL & HUNT, Baltimore, Md. (vide Grips).

**DUST GUARDS (For Oil Boxes).**  
 UNLUBRIZED OIL, Wilmington, Delaware.  
 (New York offices, 15 DeY st.)

**ELECTRIC RAILWAY CASTINGS.**  
 Wm. Wharton, Jr., & Co. (Incorporated), 25th st. and  
 Washington av., Philadelphia, Pa.

**ELECTRIC RAILWAY PATENTS.**  
 OVERHEAD CONDUCTOR ELECTRIC RAILWAY  
 CO. (The), (Thomas B. Kerr, Sec'y.), Pittsburg, Pa.

**ELECTRIC RAILWAYS (Equipment).**  
 BENTLEY-KNIGHT ELECTRIC RAILWAY CO., 115  
 Broadway, New York. (Instructors, Rhode Island  
 Locomotive Works).  
 DART, ELECTRIC CO. (The), 115 Broadway,  
 New York. (Factory at Jersey City, N. J.) (See  
 Cos.—Electric Power Co., 115 Broadway, New York;  
 Safety Electric Power Co., 115 Broadway, New York;  
 Safety Electric Power & Railway Co., 41 Wall st.,  
 New York; Mass. Electric Power Co., Boston; and  
 Electric Island Electric Power Co., Providence, R. I.)  
 SAFETY ELECTRIC CONSTRUCTION CO. (Safe Sys-  
 tem), 41 Wall st., New York. (Factory at Green-  
 ville, N. J.)

SPRAGUE ELECTRIC RAILWAY & MOTOR CO. 16  
 and 18 Broad st., New York. (Special work at New  
 York factory, 510 W. 30th st. Standard work at  
 the Edison Machine Works, Schenectady, N. Y.)  
 (Branches—55 Oliver st., Boston; 20 Caron delet st.,  
 New Orleans; 63 Jefferson av., Detroit; 185 Deau-  
 born st., Chicago; 304 Locust st., St. Louis; 119 S.  
 4th st., Philadelphia; 117 Public st., Cleveland, O.)  
 WALKER, E. D., 15, 17 and 19  
 21 N. Clinton st., Chicago. (Branch—45 Broadway,  
 New York.)

**ELEVATED RAILWAYS.**  
 Melges' Elevated Railway Construction Co., 225 Bridge  
 st., East Cambridge, Boston, Mass.  
 Riley Railway Construction Co. (The), Bloomfield, N. J.  
 (Branches—93 MIK st., Boston; 196 Greenwich st.,  
 New York.)

**ENGINEERS' INSTRUMENTS (Survey).**  
 ALOE, A. S., & Co., 300 N. Fourth st., St. Louis, Mo.  
**FAIR BRIDGES.**  
 ADAMS & WESTLAKE CO. (The), 110 Ontario st.,  
 Chicago; 115 Broadway, New York.  
 Beman, J. W., Indianapolis, Ind.  
 BROWNELL & WIGHT CAR CO., 2300 Broadway, St.  
 Louis, Mo.

Greeley, The E. S., & Co., 5 and 7 Day st., New York.  
 Haines Bros., 55 Broadway, New York.  
 HORACE A. KEEFER CO. (The), Kansas City, Mo.  
 JOHNSON STEEL STREET RAIL CO. (The), Johns-  
 town, Pa.  
 Laclede Car Co., 4500 N. Second st., St. Louis, Mo.  
 LEWIS & FOWLER MFG. CO. (The), 27 to 35 Wal-  
 worth st., Brooklyn, N. Y.

MARTIN, RUFUS, & CO., 13 Park Row, New York.  
 MASTON, MILTON L. (agent for Slawson's boxes), 365  
 W. 11th st., Philadelphia, Pa.  
 PUGH & RUSSELL, Stewart Bldg., New York; Phenix  
 Bldg., Chicago, Ill.

STEPHENSON (JOHN) COMPANY, Lim., New York.  
 WALKS MFG. CO., 76 and 78 E. Water st., Syracuse,  
 New York.  
 White & Sandgren, 1804 Mission st., San Francisco, Cal.  
 Whiting, T. J., 7a South Place, Finsbury, London.



**FARE COLLECTORS (Automobile).**  
 Greeley, The E. S. & Co., 5 and 7 Dey st., New York  
 Haines Bros., 55 Broadway, New York.  
 Kaye (Joseph) & Sons, Leeds. (London office—93 High Holborn, W. C., London.)  
 Laclede Car Co., 4500 N. Second st., St. Louis, Mo.  
 LEWIS & FOWLER MFG. CO. (The), 27 to 35 Walworth st., Brooklyn, N. Y.  
 MARTIN, RUFUS & CO., 13 Park Row, New York.  
 STEPHENSON (JOHN) COMPANY, Limited, 47 E. 27th st., New York. (Branch—Phenix Bldg., Chicago.)

**FARE REGISTERERS.**  
 Bell Punch Co. (The), Limited, 24 Tabernacle st., Finsbury Cir., E. C., London.  
 Brill (J. G.) Co., Philadelphia.  
 Greeley, The E. S. & Co., 5 and 7 Dey st., New York.  
 Haines Bros., 55 Broadway, New York.  
 Kaye (Joseph) & Sons, Leeds. (London office—93 High Holborn, W. C., London.)  
 Laclede Car Co., 4500 N. Second st., St. Louis, Mo.  
 LEWIS & FOWLER MFG. CO. (The), 27 to 35 Walworth st., Brooklyn, N. Y.  
 Mardall Fare Register Co., Cleveland, O.  
 MARTIN, RUFUS & CO., 13 Park Row, New York.  
 Post & Company, Cincinnati, Ohio.  
 PUGH & RUSSELL, Stewart Bldg., New York; Phenix Bldg., Chicago, Ill.

**RAILWAY REGISTER MFG. CO.** (Jas. McCredie, president, Buffalo, N. Y.); Ed. Reade, manager, 1193 Broadway, New York; J. F. Courtney, general agent, 423 Walnut st., Philadelphia, Pa.  
 Standard Index & Register Co., 138 Fulton st., New York.  
 STEPHENSON (JOHN) COMPANY, Limited, 47 E. 27th st., New York. (Branch—Phenix Bldg., Chicago.)

**FASTENINGS.**  
 Cambria Iron Co., 218 S. 4th st., Philadelphia. (vide Axles.)

**FARE CUTTERS.**  
 Belle City Mfg. Co., Racine, Wis.  
 Kaestner, Charles & Co., 303 S. Canal, Chicago.  
 MARTIN, RUFUS & CO., 13 Park Row, New York.  
 PUGH & RUSSELL, Stewart Bldg., New York; Phenix Bldg., Chicago, Ill.  
 Ross Manufacturing Co., Springfield, O.

**FEED MILLS.**  
 Fox & Mfg. Co., Springfield, O.  
 Kaestner, Chas. & Co., 303 S. Canal st., Chicago.  
 MARTIN, RUFUS & CO., 13 Park Row, New York.  
 Noyes, The J. & S. Line, 211 E. 32d st., New York. (Branches at Chicago, Ill., and Minneapolis, Minn.)  
 PUGH & RUSSELL, Stewart Bldg., New York; Phenix Bldg., Chicago, Ill.

**FLOOR PAINT.**  
 CHICAGO WOOD FINISHING CO., 143 and 145 S. Clinton st., Chicago, Ill.

**ROLLING MATS.**  
 BEALIE, EDWARD, 1193 Broadway, New York (Factory—Cedar Rapids, Iowa.)  
 Warneck & Toller, 211 E. 32d st., New York. ("Rolling Wood Mat.")

**FROGS.**  
 ANDREWS, FRANK H., 545 W. 33rd st., New York (vide Brakes).  
 Ayres, Abraham, 502 to 518 W. 45th st., New York.  
 BALTIMORE CAR WHEEL CO. (The), Baltimore, Md. (vide Car Wheels).  
 Chester Steel Castings Co., 407 Library st., Philadelphia.  
 King, Wm. P., 95 Liberty st., New York.  
 FULTON FOUNDRY, Cleveland, O. (vide Axles).  
 Greeley, The E. S. & Co., 5 and 7 Dey st., New York.  
 HERRAGE, A. A., 305 E. 14th st., New York.  
 HOWARD, CHILDS & Co., Hamilton Bldg., Pittsburgh, Pa.  
 JOHNSON STEEL STREET RAIL CO. (The), Johnston, Pa. (vide Cable Cars).  
 Johnson Railroad Frog & Switch Co., 307 Walnut st., Philadelphia.  
 LEWIS & FOWLER MFG. CO. (The), 27 to 35 Walworth st., Brooklyn, N. Y.  
 Metairie Street Railway Supply Co., Albany, N. Y. (vide Cable Yokes).

MEYENBURG, O. W. & Co., 204 N. 3d st., St. Louis, Mo. (Branch—Phenix Bldg., Chicago, Ill.)  
 PENNSYLVANIA CAR WHEEL CO. (The), 131 Walnut st., Philadelphia.  
 PUGH & RUSSELL, Stewart Bldg., New York; Phenix Bldg., Chicago, Ill.  
 WAY FOUNDRY CO. (The), 23rd and Wood sts., Philadelphia, Pa.  
 Wm. Wharton, Jr. & Co. (Incorporated), 25th st. and Washington ave., Philadelphia, Pa.  
 Whiting Manufacturing Co., Cedar Rapids, Iowa.

**GLASS.**  
 Mississippi Glass Co., Main and Angelica sts., St. Louis, Mo. (Agent—Chas. S. King, 109 Chambers st., New York).  
 The Western Sand Blast Co., nw. cor. Clinton and Jackson sts., Chicago, Ill.

**GREASE.**  
 Chicago Lubricant Mfg. Co., 51 Dearborn st., Chicago.  
 Leib Lubricating Co., Buffalo, N. Y. (Agents—Fraitz & Emis, Washington Ave., Philadelphia, Pa.)  
 MARTIN, RUFUS & CO., 13 Park Row, New York.

**GRINDERS (Car Wheel).**  
 Greeley, The E. S. & Co., 5 and 7 Dey st., New York.  
 Post & Company, Cincinnati, Ohio.  
 PUGH & RUSSELL, Stewart Bldg., New York; Phenix Bldg., Chicago, Ill.

**GRIPS (Cable).**  
 ANDEKS, D. B., 2313 Ridge Ave., Philadelphia, Pa.  
 BALTIMORE CAR WHEEL CO. (The), Baltimore, Md. (vide Car Wheels).  
 Chester Steel Castings Co., 407 Library st., Philadelphia.  
 Gould, John H. & Gould & Co., 305 to 311 S. 2d st. (manufacture), ne. cor. 9th and Market sts., and 37 and 39 N. 2d st., Philadelphia.  
 JOHNSON TOOL & INDUSTRY, Ind.  
 Laclede Car Co., 4500 N. Second st., St. Louis, Mo.  
 LANE & BODLEY CO. (The), 267-283 Water st., Cincinnati, Ohio.  
 POOLE & HUNT, Baltimore, Md. (Works at Woodberry, Maryland).  
 Van Duzen & Tit, 102 and 104 E. 2d st., Cincinnati, O.  
 Wm. Wharton, Jr. & Co. (Incorporated), 25th st. and Washington ave., Philadelphia, Pa.

**ROOMING MACHINES.**  
 PUGH & RUSSELL, Stewart Bldg., New York; Phenix Bldg., Chicago, Ill.

**GROOVED CURVES.**  
 ANDREWS, FRANK H., 545 W. 33rd st., New York (vide Brakes).  
 Craig, Wm. P., 95 Liberty st., New York.  
 FULTON FOUNDRY, Cleveland, Ohio (vide Axles).

Haines Bros., 55 Broadway, New York.  
 HOWARD, CHILDS & Co., Hamilton Bldg., Pittsburgh, Pa.  
 JOHNSON STEEL STREET RAIL CO. (The), Johnston, Pa. (vide Cable Yokes).  
 LEWIS & FOWLER MFG. CO. (The), 27 to 35 Walworth st., Brooklyn, N. Y.  
 MEYENBURG, O. W. & Co., 204 N. 3d st., St. Louis, Mo. (Branch—Phenix Bldg., Chicago, Ill.)  
 PENNSYLVANIA CAR WHEEL CO. (The), 131 Walnut st., Philadelphia.  
 PUGH & RUSSELL, Stewart Bldg., New York; Phenix Bldg., Chicago, Ill.  
 SNEAD & BIBB, Louisville, Ky.  
 Wm. Wharton, Jr. & Co. (Incorporated), 25th st. and Washington ave., Philadelphia, Pa.

**HAMES COUPLERS.**  
 DICKSON, C. H., Sec'y Northern Central Ry. Co., St. Louis, Mo.

**HAINES.**  
 Brill (J. G.) Co., Philadelphia.  
 Leckie (John) & Co., London (12 St. Mary Ave. E. C.), Glasgow, and Washb., Eng.  
 MARKS, W. S. & Co., 12 Park Row, New York.  
 PUGH & RUSSELL, Stewart Bldg., New York; Phenix Bldg., Chicago, Ill.

**HEAD-LIGHTS & LANTERNS.**  
 ADAMS & WESTLAKE CO. (The), 110 Ontario st., Chicago, Ill.; 115 Broadway, New York.

**HOISE PADS.**  
 McClain, E. C., Cincinnati.

**HOISE-SHOE NAILS.**  
 Champion Horse Nail Co., Appleton, Wis.  
 PUGH & RUSSELL, Stewart Bldg., Pittsburgh, Pa.  
 Kimbark, S. D., Michigan ave. and Lake st., Chicago, Ill.  
 Northwestern Horse Nail Co., 232 S. Clinton st., Chicago.  
 PUGH & RUSSELL, Stewart Bldg., New York; Phenix Bldg., Chicago, Ill.  
 Putnam Nail Co. (The), Nesuset P. O., Boston, Mass.  
 The United Horse Shoe & Nail Co., Limited, 115 Cannon st., E. C., London.

**HOISE SADDLES.**  
 BRYDEN FORGED HORSE SHOE WORKS, 113-117 E. 10th St., Philadelphia, Pa. (General Sales Agent—J. B. White, 194 West St., New York).  
 HOWARD, CHILDS & Co., Hamilton Bldg., Pittsburgh, Pa.  
 PUGH & RUSSELL, Stewart Bldg., New York; Phenix Bldg., Chicago, Ill.  
 The United Horse Shoe and Nail Co., Limited, 115 Cannon st., E. C., London.

**HOISE-SHOE VISES.**  
 BURKE, P. F., 360 Dorchester av., Boston, Mass. (vide Toe Calks).

**HYDRAULIC JACKS.**  
 Brill (J. G.) Co., Philadelphia.  
 Greeley, The E. S. & Co., 5 and 7 Dey st., New York.  
 HOWARD, CHILDS & Co., Hamilton Bldg., Pittsburgh, Pa.  
 Post & Company, Cincinnati, Ohio.  
 PUGH & RUSSELL, Stewart Bldg., New York; Phenix Bldg., Chicago, Ill.  
 Watson & Stillman, 210 E. 43rd st., New York.

**JOINT PLATES.**  
 WAY FOUNDRY CO. (The), 23rd and Wood sts., Phila. (vide Brakes).

**JOURNAL BOXES.**  
 ANDREWS, FRANK H., 545 W. 33rd st., New York (vide Brakes).  
 BARKER, W. S. & GRAFF, care Brown, Shipley & Co., London (vide Car Starters).  
 BALTIMORE CAR WHEEL CO. (The), Baltimore, Md. (vide Car Wheels).  
 BEMIS CAR BOX CO., Springfield, Mass.  
 Brill (J. G.) Co., Philadelphia.  
 BROWN & SULLIVAN SUPPLY CO. (The), 44 Walworth st., Brooklyn, New York.  
 BROWNELL & WIGHT CAR CO., 2300 Broadway, St. Louis, Mo.  
 Chapin Mfg. Co., 69 Wall st., New York.  
 Chester Steel Castings Co., 407 Library st., Philadelphia.  
 FULTON FOUNDRY, Cleveland, Ohio (vide Axles).  
 Greeley, The E. S. & Co., 5 and 7 Dey st., New York.  
 HOWARD, CHILDS & Co., Hamilton Bldg., Pittsburgh, Pa.  
 Keston Supply Co., Cincinnati, Ohio.  
 LEWIS & FOWLER MFG. CO. (The), 27 to 35 Walworth st., Brooklyn, N. Y.  
 MARTIN, RUFUS & CO., 13 Park Row, New York.  
 MEYENBURG, O. W. & Co., 204 N. 3d st., St. Louis, Mo. (Branch—Phenix Bldg., Chicago.)  
 Post & Company, Cincinnati, Ohio.  
 PUGH & RUSSELL, Stewart Bldg., New York; Phenix Bldg., Chicago, Ill.

SNEAD & BIBB, Louisville, Ky.  
 STEPHENSON (JOHN) COMPANY, Limited, 47 E. 27th st., New York. (Branch—Phenix Bldg., Chicago.)  
 STREET RAILWAY SUPPLY CO., Cleveland, Ohio.  
 Van Duzen & Tit, 102 and 104 E. 2d st., Cincinnati, O.  
 Wm. Wharton, Jr. & Co. (Incorporated), 25th st. and Washington ave., Philadelphia, Pa.  
 Whiting Mfg. Co., Cedar Rapids, Iowa.  
 WHITNEY, A. & SONS, Philadelphia, Pa.

**KNIVES.**  
 ANDREWS, FRANK H., 545 W. 33rd st., New York (vide Brakes).  
 WAY FOUNDRY CO. (The), 23rd and Wood sts., Philadelphia, Pa.

**LAMP HOUSE LATCHE.**  
 STEPHENSON (JOHN) COMPANY, Limited, 47 E. 27th st., New York. (Branch—Phenix Bldg., Chicago.)  
**LAMP TRIMMINGS.**  
 ADAMS & WESTLAKE CO. (The), 110 Ontario st., Chicago, Ill.; 115 Broadway, New York.  
 Post & Company, Cincinnati, Ohio.

**MATTINGS.**  
 See Upholstry, Mats, Etc.

**MOTORS.**  
 Brill (J. G.) Co., Philadelphia, Pa.  
 Haines Bros., 55 Broadway, New York.  
 PUGH & RUSSELL, Stewart Bldg., New York; Phenix Bldg., Chicago, Ill.  
 Standard Fireless Engine Co., 12 Charlres st., New Orleans.  
 Pole Star Car Motor System, 310 Chestnut st., Philadelphia.

**MOTORS (Electric).**  
 BENTLEY-KNIGHT ELECTRIC RAILWAY CO., 115 Broadway, New York.  
 Cleveland Electric Motor Co., First Nat'l Bank Bldg., Cleveland, Ohio, (vide Contractors).

DAFT ELECTRIC LIGHT CO. (The), 115 Broadway, New York.  
 Greeley, The E. S. & Co., 5 and 7 Dey st., New York.  
 Haines Bros., 55 Broadway, New York.  
 Henry Electric Railway Co., Kansas City, Mo.  
 HOLLAND & KEEFER CO. (The), Kansas City, Mo.  
 J. B. HERRAGE, 305 E. 14th st., New York.  
 Keith, N. S., 40 Nevada Block, San Francisco, Cal.  
 MARTIN, RUFUS & CO., 13 Park Row, New York.  
 PUGH & RUSSELL, Stewart Bldg., New York; Phenix Bldg., Chicago, Ill.

SAPPHY ELECTRIC CONSTRUCTION CO. (DAFT SYSTEM), 41 Wall st., New York.  
 STREET RAILWAY SUPPLY CO. (The), Cleveland, Ohio.  
 VAN DEPOELE ELECTRIC MFG. CO., 15 to 19 Clinton st., Chicago, Ill. (Branch—45 Broadway), N. Y.

**MOTORS (Gas).**  
 The Connelly Motor Co., 177 Broadway, New York.

**MOTORS (Steam.)**  
 BALTIMORE LACROIXE WOLKES, Philadelphia.  
 Black, Hawthorn & Co., Gateshead-on-Tyne, England.  
 Dick, Kerr & Co., 101 Leadenhall st., E. C., London (vide Brakes).  
 Falcon Engines and Cars, Limited, Loughborough, Eng. (London Office—1 Coleman st., E. C.).  
 Greeley, The E. S. & Co., 5 and 7 Dey st., New York.  
 Green, Thos. & Son, Limited, Smithfield Iron Works, Leeds, & Surrey Works, Blackfriars Road, E. C., London.  
 Haines Bros., 55 Broadway, New York.  
 Henschel & Sohn, Cassell, Germany.  
 New York Safety Power Co., 64 S. Canal st., Chicago.  
 PORTER, H. K. & Co., Pittsburgh, Pa.  
 PUGH & RUSSELL, Stewart Bldg., New York; Phenix Bldg., Chicago, Ill.

**OFFICE FURNITURE, PAPER Etc.**  
 ALICE, A. S. & Co., 309 N. 4th st., St. Louis, Mo.  
 Hale & Kilham Mfg. Co. (The), 45 and 50 N. 6th st., Philadelphia, Pa.  
 The Globe Co., Cincinnati, Ohio.

**OIL AND DIST LIGHT CALC GRADING.**  
 BALTIMORE CAR WHEEL CO. (The), Baltimore, Md. (vide Car Wheels).

**OILS.**  
 Duncan, Watson & Co., Dashiwood House, New Broad st., E. C., London.  
 Home Oil Co., Rochester, N. Y. (Branches—208 Home Insurance Building, Chicago; 10th and Spruce sts., St. Louis, Mo.; 96 Water st., New York; 17 Com. Bldg., Chicago; 100 State St., Boston.)  
 First av., Pittsburgh; 305 Walnut st., Philadelphia.  
 2125 Wash. st., St. Minneapolis; 37 Smith's Whf., Baltimore, Md.; 138 St. James St., Montreal, and 36 King st., West, Toronto, Canada.)

**OMNIBUS HARDWARE.**  
 ADAMS & WESTLAKE CO. (The), 110 Ontario st., Chicago; 115 Broadway, New York.

**PAINTS.**  
 Brill (J. G.) Co., Philadelphia.  
 BROWNELL & WIGHT CAR CO. 2300 Broadway, St. Louis, Mo.  
 CHICAGO WOOD FINISHING CO., 143 and 145 S. Clinton st., Chicago, Ill.  
 COFFIN, DEY & Co., 176 Randolph st., Chicago, Ill.  
 IRON CLAD PAINT CO., 3 Case Bldg., Cleveland, O.  
 Laclede Car Co., 4500 N. Second st., St. Louis, Mo.  
 Lowes Metallic Paint Co., Chattanooga, Tenn.  
 MARTIN, RUFUS & CO., 13 Park Row, New York.  
 Peabody, Hy. W. & Co., Mason Building Boston.  
 Post & Company, Cincinnati, Ohio.  
 PUGH & RUSSELL, Stewart Bldg., New York; Phenix Bldg., Chicago, Ill.  
 Sherwin-Williams Co. (The), Cleveland, Ohio (vide Brakes).  
 Valentine & Co., 245 Broadway, New York. (Branches—65 Lake st., Chicago; 153 Milk st., Boston; 21 Rue de Lappe, Paris.)

**PANELS.**  
 Brill (J. G.) Co., Philadelphia.  
 BROWNELL & WIGHT CAR CO. 2300 Broadway, St. Louis, Mo.  
 KULLMAN CAR CO., 490 St. Clair st., Cleveland, O.  
 Laclede Car Co., 4500 N. Second st., St. Louis, Mo.  
 LEWIS & FOWLER MFG. CO. (The), 27 to 35 Walworth st., Brooklyn, N. Y.  
 PUGH & RUSSELL, Stewart Bldg., New York; Phenix Bldg., Chicago, Ill.

SNEAD & BIBB, Louisville, Ky.  
 STEPHENSON (JOHN) COMPANY, Limited, 47 E. 27th st., New York. (Branch—Phenix Bldg., Chicago.)  
 STREET RAILWAY SUPPLY CO., Cleveland, Ohio.  
 Wm. Wharton, Jr. & Co. (Incorporated), 25th st. and Washington ave., Philadelphia, Pa.  
 Whiting Mfg. Co., Cedar Rapids, Iowa.  
 WHITNEY, A. & SONS, Philadelphia, Pa.

**PEDESTALS.**  
 ANDREWS, FRANK H., 545 W. 33rd st., New York (vide Brakes).  
 Ayres, Abraham, 502 to 518 W. 45th st., New York.  
 BALTIMORE CAR WHEEL CO. (The), Baltimore, Md. (vide Car Wheels).  
 BEMIS CAR BOX CO., Springfield, Mass.  
 Brill (J. G.) Co., Philadelphia.  
 BROWNELL & WIGHT CAR CO., 2300 Broadway, St. Louis, Mo.  
 FULTON FOUNDRY, Cleveland, Ohio (vide Axles).  
 Laclede Car Co., 4500 N. Second st., St. Louis, Mo.  
 LEWIS & FOWLER MFG. CO. (The), 27 to 35 Walworth st., Brooklyn, N. Y.  
 PUGH & RUSSELL, Stewart Bldg., New York; Phenix Bldg., Chicago, Ill.

SNEAD & BIBB, Louisville, Ky.  
 STEPHENSON (JOHN) COMPANY, Limited, 47 E. 27th st., New York. (Branch—Phenix Bldg., Chicago.)  
 STREET RAILWAY SUPPLY CO., Cleveland, Ohio.  
 Wm. Wharton, Jr. & Co. (Incorporated), 25th st. and Washington ave., Philadelphia, Pa.  
 Whiting Mfg. Co., Cedar Rapids, Iowa.  
 WHITNEY, A. & SONS, Philadelphia, Pa.

**PHOSPHOR BRONZE, Etc.**  
 Tutal Smelting Works, 760 So. Broad st., Philadelphia.

**PHOSPHOR BRONZE CABLE GRIPS.**  
 Van Duzen & Tit, 102 and 104 E. Second st., Cincinnati, Ohio.

**POLISHES.**  
 CHICAGO WOOD FINISHING CO., 143 and 145 S. Clinton st., Chicago, Ill.  
 CLINE MFG. CO., 277 and 279 S. Canal st., Chicago.  
 Gould, John H. & Gould & Co., Philadelphia (vide Grips).  
 HERRAGE, A. A., 305 E. 14th st., New York.  
 PUGH & RUSSELL, Stewart Bldg., New York; Phenix Bldg., Chicago, Ill.

**POLISHING MACHINERY.**  
 Watson & Stillman, 210 E. 43rd st., New York.



**PRESSES (Car Wheel).**  
**ANDREWS, FRANK H.,** 545 W. 33rd st., New York (vide Brakes).  
 Brill (J. G.) Co., Philadelphia.  
 Greeley, The E. S., & Co., 5 and 7 Day st., New York.  
 PUGH & RUSSELL, Stewart Bldg., New York; Phenix Bldg., Chicago, Ill. (vide Electric Light Co.).  
 Watson & Stillman, 210 E. 43rd st., New York.

**PULLEYS AND SHEAVES.**  
**LANE & BODLEY CO. (The),** 267-283 Water st., Cincinnati, O.  
**POOLE & HUNT,** Baltimore, Md. (vide Grips).

**PUNCHES AND SHEARS.**  
**LANE & BODLEY CO. (The),** 267-283 Water st., Cincinnati, O.  
**WATSON & STILLMAN,** 210 E. 43rd st., New York.  
**RAILWAY REGISTER MANFG. CO.,** 1193 Broadway, New York (vide Registering Punches).

**PURCHASING AGENTS.**  
**Peabody, Henry W., & Co.,** Boston (vide Paints).

**RAILS (Curved).**  
**ANDREWS, FRANK H.,** 545 W. 33rd st., New York (vide Brakes).  
 Ayres, Abraham, 502 to 518 W. 45th st., New York.  
 Craig, Wm. P., 95 Liberty st., New York.  
**FULTON FOUNDRY,** Cleveland, O. (vide Axles).  
**Haines Bros.,** 55 Broadway, New York.  
**HORACE A. KEEFER CO. (The),** Kansas City, Mo.  
 Howard, Childs & Co., Hamilton Bldg., Pittsburgh, Pa.  
**JOHNSON STEEL STREET RAIL CO. (The),** Johnstonown, Pa. (vide Cable Vokes).  
**LEWIS & FOWLER MFG. CO. (The),** 27 to 35 Walworth st., Brooklyn, N. Y.

**LONGSTREET, D. F.,** Providence, R. I. (Agents—Wm. Wharton, Jr., & Co., Incorporated), 25th st. and Washington ave., Philadelphia, Pa.  
**Metallic Street Railway Supply Co.,** Albany, N. Y. (vide Cable Vokes).  
 Meyersburg, W., & Co., 204 N. 3d st., St. Louis, Mo. (Branch—Phenix Bldg., Chicago, Ill.)  
**Pennsylvania Steel Co.,** Philadelphia (vide Axles).  
**PUGH & RUSSELL, Stewart Bldg.,** New York; Phenix Bldg., Chicago, Ill.  
 St. Thomas Car Wheel Co., St. Thomas, Out. Canada.  
**STREET RAILWAY SUPPLY CO.,** Cleveland, Ohio.  
 Wm. Wharton, Jr., & Co. (Incorporated), 25th st. and Washington ave., Philadelphia, Pa.  
 Whiteley Manufacturing Co., Cedar Rapids, Iowa.

**RAILS (Steel).**  
**ANDREWS, FRANK H.,** 545 W. 33rd st., New York (vide Brakes).  
 Ayres, Abraham, 502 and 518 W. 45th st., New York.  
 Cambria Iron Co., 218 S. 4th st., Philadelphia. (vide Axles).  
 Carnegie, Thipps & Co., Limited, 48 Fifth ave., Pittsburgh, Pa.  
 Craig, Wm. P., 95 Liberty st., New York.  
 Erie Iron, Steel & Coal Co., Erie, Pa.  
**FULTON FOUNDRY,** Cleveland, O. (vide Axles).  
**Haines Bros.,** 55 Broadway, New York.  
**HORACE A. KEEFER CO. (The),** Kansas City, Mo.  
 Howard, Childs & Co., Hamilton Bldg., Pittsburgh, Pa.  
**JOHNSON STEEL STREET RAIL CO. (The),** Johnstonown, Pa. (vide Cable Vokes).  
 Leacle, Car & Foundry Co., 4500 N. Second st., St. Louis, Mo.; 8 Oliver st., Boston; Stewart Bldg., New York; Johnston Bldg., Cincinnati; 199 E. Main st., Louisville, Ky.  
**LONGSTREET, D. F.,** Providence, R. I. (Agents—Wm. Wharton, Jr., & Co., Incorporated), 25th st. and Washington ave., Philadelphia, Pa.  
**Metallic Street Railway Supply Co.,** Albany, N. Y. (vide Cable Vokes).  
 Meyersburg, W., & Co., 204 N. 3d st., St. Louis, Mo. (Branch—Phenix Bldg., Chicago, Ill.)  
 North Chicago Rolling Mill Co., Metropolitan block, Chicago. (Branch—New Insurance Bldg., Milwaukee).  
**Pennsylvania Steel Co.,** Philadelphia (vide Axles).  
 Post & Company, Cincinnati, Ohio.  
**PUGH & RUSSELL, Stewart Bldg.,** New York; Phenix Bldg., Chicago, Ill.  
 Springfield Iron Co. (The), Springfield, Ill. (Branch—115 Dearborn st., Chicago).  
**STREET RAILWAY SUPPLY CO.,** Cleveland, Ohio.  
 Wm. Wharton, Jr., & Co. (Incorporated), 25th st. and Washington ave., Philadelphia, Pa.  
 Worcester Steel Works, Worcester, Mass.

**RAILS (Tram and T.)**  
**HATHAWAY & ROBISON,** 14 Case Bldg., Cleveland, O.  
 Tudor Iron Works, 509 N. 3rd st., St. Louis, Mo.

**RAILWAYS (Cable) BUILDERS.**  
**ANDREWS, FRANK H.,** 545 W. 33rd st., New York (vide Brakes).  
 Baker, W. S. GRAFF, care Brown, Shipley & Co., London (vide Car Starters).  
 Gould, J. H., & Gould & Co., Philadelphia. (vide Grips).  
 Haines Bros., 55 Broadway, New York.  
 Hinkley, F. E., & Co., Room 606 First National Bank Bldg., Chicago, Ill.  
**Metallic Street Railway Supply Co.,** Albany, N. Y. (vide Cable Vokes).  
 Miller, D. J., 224 Broadway, New York.  
 National Cable & Rope Co., 140 Nassau st., New York.  
 Patent Cable Tramways Corporation, Limited, Victoria Mansions, Westminster, S. W., London.  
 Wm. Wharton, Jr., & Co. (Incorporated), 25th st. and Washington ave., Philadelphia, Pa.  
 Wright Construction Co., Phenix Bldg., Chicago.  
 Wright, Meyersburg & Co., St. Louis, Mo.

**RAILWAYS (Electric) BUILDERS.**  
**BENTLEY-KNIGHT ELECTRIC RAILWAY CO.,** 115 Broadway, New York.  
 Chaudron & Co. (Agents for Sprague motors), 119 S. 4th st., Philadelphia.  
**Cleveland Electric Motor Co. (vide Contractors and Builders).**  
**DAFT ELECTRIC LIGHT CO. (The),** 115 Broadway, New York.  
 Haines Bros., 55 Broadway, New York.  
 Harris, T. Wm., & Co., 2 Nassau st., room 17, New York.  
 Henry Electric Railway Co. (The), Kansas City, Mo.  
 Julett Electric Co., 120 Broadway, New York.  
**Metallic Street Railway Supply Co.,** Albany, N. Y. (vide Cable Vokes).  
**SAFETY ELECTRIC CONSTRUCTION CO. (DAFT SYSTEM),** 41 Wall st., New York.  
**SPRAGUE ELECTRIC RAILWAY MOTOR CO.,** 16 and 18 Broad st., New York (vide Electric Railways).  
 V. A. S. Electric Co., Denver, Colo.  
**VAN DEKORP ELECTRIC MANUFACTURING CO.,** 15 to 21 N. Clifton st., Chicago; 45 Broadway, N. Y.  
 Wm. Wharton, Jr., & Co. (Incorporated), 25th st. and Washington ave., Philadelphia, Pa.

**RAILWAYS (Horse) BUILDERS.**  
**BAKER, W. S. GRAFF,** care Brown, Shipley & Co., London (vide Car Starters).  
 Craig, Wm. P., 95 Liberty st., New York.  
 Haines Bros., 55 Broadway, New York.  
 Harris, T. Wm., & Co., 2 Nassau st. (room 17), New York.

**HATHAWAY & ROBISON,** 14 Case Bldg., Cleveland, O.  
**JOHNSON STEEL STREET RAIL CO. (The),** Johnstonown, Pa. (vide Rails, Steel).  
**LEWIS & FOWLER MFG. CO. (The),** 27 to 35 Walworth st., Brooklyn, N. Y.  
**MARTIN, RUFUS, & CO.,** 13 Park Row, New York.  
**Post & Company,** Cincinnati, Ohio.  
**PUGH & RUSSELL, Stewart Bldg.,** New York; Phenix Bldg., Chicago, Ill.  
**SMITH, JOSEPHINE D.,** 350 Pearl st., New York.

**ROAD CEMENTS.**  
 Empire Warehouse Co., 198-204 Market st., Chicago, Ill.  
 McLaughlin, Le Granda, O.  
 Peabody, Henry W., & Co., Boston (vide Paints).

**ROUGH STUFF.**  
**CHICAGO WOOD FINISHING CO.,** 143 and 145 S. Clinton st., Chicago, Ill.

**RUBBER TREADS (For Car Steps).**  
**MARTIN, RUFUS, & CO.,** 13 Park Row, New York.  
 Rubberstep Mfg. Co., 43 Haverhill st., Boston, Mass.

**RUNNING GEAR (Super Spring).**  
**STEPHENSON (JOHN) COMPANY, Limited,** 47 E. 27th st., New York.  
**LEWIS & FOWLER MFG. CO. (The),** 27 to 35 Walworth st., Brooklyn, N. Y.

**SAFETY PULL IRONS.**  
 Brill (J. G.) Co., Philadelphia.

**SAND BLOBS.**  
 Brill (J. G.) Co., Philadelphia.

**CAR TRACK FRICTION APPLANCE CO. (The),** 19 Tremont Row (room 4), Boston, Mass. (W. T. Dutler, General Manager, 100 State st., Boston, Mass.).  
**Jordan Mills Mfg. Co. (The),** 32 Nassau st., New York.  
**Laclede Car Co.,** 4500 N. Second st., St. Louis, Mo.  
**LEWIS & FOWLER MFG. CO. (The),** 27 to 35 Walworth st., Brooklyn, N. Y.

**SEATS AND SEAT SPRINGS.**  
 Brill (J. G.) Co., Philadelphia.

**BROWNELL & WIGHT CAR CO.,** 2300 Broadway, St. Louis, Mo.  
 Dayton Mfg. Co. (The), Dayton, Ohio.  
 Greeley, The E. S., & Co., 5 and 7 Day st., New York.  
 Hale & Kilburn Mfg. Co. (The), 48 and 50 N. 6th st., Philadelphia.

**HARTFORD WOVEN WIRE MATTRESS CO. (The),** 100 W. 36th st., New York.  
**Laclede Car Co.,** 4500 N. Second st., St. Louis, Mo.  
**MARTIN, RUFUS, & CO.,** 13 Park Row, New York.  
**Post & Company,** Cincinnati, Ohio.  
**PUGH & RUSSELL, Stewart Bldg.,** New York; Phenix Bldg., Chicago, Ill.

**SHAPING HANGERS AND PULLEYS.**  
**LANE & BODLEY CO. (The),** 267-283 Water st., Cincinnati, O.

**SIGNAL LIGHTS.**  
**ADAMS & WESLAKO CO. (The),** 110 Ontario st., Chicago, Ill.; 115 Broadway, New York.  
 Brill (J. G.) Co., Philadelphia.

**BROWNELL & WIGHT CAR CO.,** 2300 Broadway, St. Louis, Mo.  
 Greeley, The E. S., & Co., 5 and 7 Day st., New York.  
 Laclede Car Co., 4500 N. Second st., St. Louis, Mo.  
**LEWIS & FOWLER MFG. CO. (The),** 27 to 35 Walworth st., Brooklyn, N. Y.

**MARTIN, RUFUS, & CO.,** 13 Park Row, New York.  
**Post & Company,** Cincinnati, Ohio.  
**PUGH & RUSSELL, Stewart Bldg.,** New York; Phenix Bldg., Chicago, Ill.  
**SMITH, JOSEPHINE D.,** 350 Pearl st., New York.

**SNOW PLOWS.**  
**ANDREWS, FRANK H.,** 545 W. 33rd st., New York (vide Brakes).  
 Brill (J. G.) Co., Philadelphia.

**BROWNELL & WIGHT CAR CO. (The),** 44 Walworth st., Brooklyn, N. Y.  
 Craig, Wm. P., 95 Liberty st., New York.  
 Day, Augustus, 23 Park Place, Detroit, Mich.  
 Haines Bros., 55 Broadway, New York.  
**JOHNSON, TOM L.,** Indianapolis, Ind.  
**LEWIS & FOWLER MFG. CO. (The),** 27 to 35 Walworth st., Brooklyn, N. Y.

**MARTIN, RUFUS, & CO.,** 13 Park Row, New York.  
**PUGH & RUSSELL, Stewart Bldg.,** New York; Phenix Bldg., Chicago, Ill.

**SPIKES AND FASTENINGS.**  
 Craig, Wm. P., 95 Liberty st., New York.  
**GREENE & ROBINSON, 14 Case Bldg.,** Cleveland, O.  
 Greeley, The E. S., & Co., 5 and 7 Day st., New York.  
 Haines Bros., 55 Broadway, New York.  
**HATHAWAY & ROBISON,** 14 Case Bldg., Cleveland, O.  
**HORACE A. KEEFER CO. (The),** Kansas City, Mo.  
 Howard, Childs & Co., Hamilton Bldg., Pittsburgh, Pa.  
**JOHNSON STEEL STREET RAIL CO. (The),** Johnstonown, Pa. (vide Rails, Steel).  
**LEWIS & FOWLER MFG. CO. (The),** 27 to 35 Walworth st., Brooklyn, N. Y.  
**MARTIN, RUFUS, & CO.,** 13 Park Row, New York.  
**PUGH & RUSSELL, Stewart Bldg.,** New York; Phenix Bldg., Chicago, Ill.

**SPICES FOR JOINING WIRE CABLES.**  
**HAZARD MANUFACTURING CO. (The),** Wilkes Barre, Pa.

**SPRING STEEL.**  
 Cambria Iron Co., 218 S. 4th st., Philadelphia. (vide Axles).

**STATIONARY ENGINE BUILDERS.**  
 Allis, Edw. F., & Co., Milwaukee, Wis.  
 Bucyrus Engine Co., Sales Agents—W. L. Simpson, 201 Telephone Building, 18 Cortland st., New York; John F. Fife, 30 Oliver st., Boston, Mass.; N. W. Robinson, cor. Clinton and Jackson sts., Chicago, Ill.; Robinson & Corey, St. Paul, Minn.; G. S. Worrier & Son, 705 Market st., St. Louis.

**Fishkill Landing Machine Co. (The),** Fishkill-on-the-Hudson, N. Y.  
 Harris, Wm. A., Providence, R. I.

Hoovers, Owens & Rentschler Co. (The), Hamilton, O.  
 HORACE A. KEEFER CO. (The), Kansas City, Mo.  
 KASNER, CHAS., & Co., 303 S. Canal st., Chicago.  
**LANE & BODLEY CO. (The),** 267-283 Water st., Cincinnati, Ohio.  
 New York Safety Steam Power Co., 64 S. Canal st., Chicago.

**Noye, The J. T. Manufacturing Co.,** Buffalo, N. Y. (Branches at Chicago, Ill., and Minneapolis, Minn.).  
 Providence Steam Engine Co., Providence, R. I.  
 Smith, Berge & Rankin, St. Louis, Mo.  
 Todd, Wm., & Co., Youngstown, Ohio.  
 Whiteley Manufacturing Co., Cedar Rapids, Iowa.

**STEAM BOILERS.**  
 Heine Safety Boiler Co., 102 North Main st., St. Louis, Mo. (Agent—J. H. Harris, 82 Madison st., Chicago).  
 Hoovers, Owens & Rentschler Co. (The), Hamilton, O.

**STORAGE BATTERIES (For Lights, &c.).**  
 Electrical Accumulator Co. (The), 44 Broadway, New York.  
 Jullien Electric Co., 120 Broadway, New York.

**SUPPLIES (General).**  
**ANDREWS, FRANK H.,** 545 W. 33rd st., New York (vide Brakes).  
 Brill (J. G.) Co., Philadelphia.

**BROWNELL & WIGHT CAR CO.,** 2300 Broadway, St. Louis, Mo.  
 Chester Steel Castings Co., 407 Library st., Philadelphia.  
 Child, O. W., & Co., 150 Broadway, New York.  
 Craig, Wm. P., 95 Liberty st., New York.  
 Dwight, E. P., 407 Library st., Philadelphia.  
 Greeley, The E. S., & Co., 5 and 7 Day st., New York.  
 Haines Bros., 55 Broadway, New York.

**HARTFORD WOVEN WIRE MATTRESS CO. (The),** 100 W. 36th st., New York.  
**HATHAWAY & ROBISON,** 14 Case Bldg., Cleveland, O.  
 Howard, Childs & Co., Hamilton Bldg., Pittsburgh, Pa.  
 Jessup, F. W., & Co., 115 Broadway, New York.  
**JOHNSON STEEL STREET RAIL CO. (The),** Johnstonown, Pa. (vide Rails, Steel).

**KIMBALL, S. B.,** Michigan Ave. and Lake st., Chicago, Ill.  
**LEWIS & FOWLER MFG. CO. (The),** 27 to 35 Walworth st., Brooklyn, N. Y.

**MARTIN, RUFUS, & CO.,** 13 Park Row, New York.  
**Metallic Street Railway Supply Co. (The),** Albany, N. Y.  
**Phenix Steel Wire Branch & Brush Co.,** 199 E. Main st., Louisville, Ky.  
 Post & Company, Cincinnati, Ohio.  
**PUGH & RUSSELL, Stewart Bldg.,** New York; Phenix Bldg., Chicago, Ill.

**SAXTON, J. C.,** 52 Broadway, New York.  
**SMITH, JOSEPHINE D.,** 350 Pearl st., New York.  
**STEPHENSON (JOHN) COMPANY, Limited,** 47 E. 27th st., New York. (Branch—Phenix Bldg., Chicago).  
**STREET RAILWAY SUPPLY CO.,** Cleveland, Ohio.  
 Wm. Wharton, Jr., & Co. (Incorporated), 25th st. and Washington ave., Philadelphia, Pa.  
 White, Edward C., 530 W. 33rd st., New York.

**SWEEPING MACHINES (Dirt or Street).**  
**BROWNELL & WIGHT CAR CO. (The),** 44 Walworth st., Brooklyn, N. Y.

**SWITCH CASTINGS.**  
**HATHAWAY & ROBISON,** 14 Case Bldg., Cleveland, O.

**SWITCH ROPES.**  
**ROEBLING'S SONS CO., JOHN A.,** 117 and 119 Liberty st., New York.

**SWITCHES.**  
**ANDREWS, FRANK H.,** 545 W. 33rd st., New York (vide Brakes).  
 Ayres, Abraham, 502 to 518 W. 45th st., New York.  
**BALTIMORE CAR WHEEL CO. (The),** Baltimore, Md. (vide Car Wheels).  
 Craig, Wm. P., 95 Liberty st., New York.  
**FULTON FOUNDRY,** Cleveland, O. (vide Axles).  
 Greeley, The E. S., & Co., 5 and 7 Day st., New York.  
 Haines Bros., 55 Broadway, New York.  
 Howard, Childs & Co., Hamilton Bldg., Pittsburgh, Pa.  
**JOHNSON STEEL STREET RAIL CO. (The),** Johnstonown, Pa. (vide Cable Vokes).  
 Johnston Railroad Frog & Switch Co., 307 Walnut st., Philadelphia.  
**LEWIS & FOWLER MFG. CO. (The),** 27 to 35 Walworth st., Brooklyn, N. Y.  
 Metallic St. Ry. Supply Co., Albany, N. Y. (vide Cable Vokes).  
 Pennsylvania Steel Co., Philadelphia (vide Axles).  
**PUGH & RUSSELL, Stewart Bldg.,** New York; Phenix Bldg., Chicago, Ill.  
**SNEAD & BIBB,** Louisville, Ky.  
**WYNE FOUNDRY CO. (The),** 23rd and Wood sts., Philadelphia, Pa.  
 Wm. Wharton, Jr., & Co. (Incorporated), 25th st. and Washington ave., Philadelphia, Pa.  
**WHITE, M. W., & Co.,** 531 W. 33rd st., New York.  
 Whiteley Mfg. Co., Cedar Rapids, Iowa.

**SWITCHES (Automatic).**  
**ANDREWS, FRANK H.,** 545 W. 33rd st., New York (vide Brakes).  
 Ayres, Abraham, 502 to 518 W. 45th st., New York.  
 Craig, Wm. P., 95 Liberty st., New York.  
**FULTON FOUNDRY,** Cleveland, O. (vide Axles).  
 Greeley, The E. S., & Co., 5 and 7 Day st., New York.  
**HATHAWAY & ROBISON,** 14 Case Bldg., Cleveland, O.  
**HORACE A. KEEFER CO. (The),** Kansas City, Mo.  
**JOHNSON STEEL STREET RAIL CO. (The),** Johnstonown, Pa. (vide Cable Vokes).  
**LEWIS & FOWLER MFG. CO. (The),** 27 to 35 Walworth st., Brooklyn, N. Y.  
 Metallic St. Ry. Supply Co., Albany, N. Y. (vide Cable Vokes).  
**PUGH & RUSSELL, Stewart Bldg.,** New York; Phenix Bldg., Chicago, Ill.

**Wm. Wharton, Jr., & Co. (Incorporated),** 25th st. and Washington ave., Philadelphia, Pa.  
**WHITE, M. W., & Co.,** 531 W. 33rd st., New York.

**TENSION CARRIAGES.**  
**LANE & BODLEY CO. (The),** Water st., Cincinnati, O.  
**POOLE & HUNT,** Baltimore, Md. (vide Grips).

**TICKETS.**  
 Bell Punch Co. (The), Limited, 24 Tabernacle st., Finsbury, E. C., London.  
 Fryer, C. A., Merchants', Northampton, England.  
 Jones (J. M. W.) Stationery & Printing Co., Dearborn st., Chicago, Ill.

**WHITE, M. W., & Co.,** 531 W. 33rd st., New York.

**TENSION CARRIAGES.**  
**LANE & BODLEY CO. (The),** Water st., Cincinnati, O.  
**POOLE & HUNT,** Baltimore, Md. (vide Grips).

**TICKETS.**  
 Bell Punch Co. (The), Limited, 24 Tabernacle st., Finsbury, E. C., London.  
 Fryer, C. A., Merchants', Northampton, England.  
 Jones (J. M. W.) Stationery & Printing Co., Dearborn st., Chicago, Ill.

**WHITE, M. W., & Co.,** 531 W. 33rd st., New York.

**TENSION CARRIAGES.**  
**LANE & BODLEY CO. (The),** Water st., Cincinnati, O.  
**POOLE & HUNT,** Baltimore, Md. (vide Grips).

**TICKETS.**  
 Bell Punch Co. (The), Limited, 24 Tabernacle st., Finsbury, E. C., London.  
 Fryer, C. A., Merchants', Northampton, England.  
 Jones (J. M. W.) Stationery & Printing Co., Dearborn st., Chicago, Ill.

**WHITE, M. W., & Co.,** 531 W. 33rd st., New York.

**TENSION CARRIAGES.**  
**LANE & BODLEY CO. (The),** Water st., Cincinnati, O.  
**POOLE & HUNT,** Baltimore, Md. (vide Grips).

**TICKETS.**  
 Bell Punch Co. (The), Limited, 24 Tabernacle st., Finsbury, E. C., London.  
 Fryer, C. A., Merchants', Northampton, England.  
 Jones (J. M. W.) Stationery & Printing Co., Dearborn st., Chicago, Ill.

**WHITE, M. W., & Co.,** 531 W. 33rd st., New York.

**TENSION CARRIAGES.**  
**LANE & BODLEY CO. (The),** Water st., Cincinnati, O.  
**POOLE & HUNT,** Baltimore, Md. (vide Grips).

**TICKETS.**  
 Bell Punch Co. (The), Limited, 24 Tabernacle st., Finsbury, E. C., London.  
 Fryer, C. A., Merchants', Northampton, England.  
 Jones (J. M. W.) Stationery & Printing Co., Dearborn st., Chicago, Ill.



**TOE CALKS.**  
BORKER, P. F., 360 Dorchester ave., Boston, Mass. (vide Calks.)  
CAGLIE & CO., Mfg. & Co., Chicago, Ill.; Livingston Harco Nail Co., New York, N. Y.  
Cambridge Iron Co., 218 E. 4th st., Philadelphia (vide Calks.)  
Howard, Childs & Co., Hamilton Building, Pittsburgh.  
PUGH & RUSSELL, Stewart Bldg., New York; Phenix Bldg., Chicago, Ill.

**TOOLS (Track and Shop).**  
BROOKLYN RAILWAY SUPPLY CO. (The), 41 Walworth st., Brooklyn, N. Y.  
Craig, Wm. F., 95 Liberty st., New York.  
Greely, The E. S., & Co., 5 and 7 Dey st., New York.  
Haines Bros., 55 Broadway, New York.  
Howard, Childs & Co., Hamilton Building, Pittsburgh.  
Lee & Hunt, Acworth Works, Nottingham, England.  
LEWIS & FOWLER MFG. CO. (The), 27 to 35 Walworth st., Brooklyn, N. Y.  
MARTIN, RUFUS, & CO., 13 Park Row, New York; Post & Company, Cincinnati, Ohio.  
PUGH & RUSSELL, Stewart Bldg., New York; Phenix Bldg., Chicago, Ill.  
STREET RAILWAY SUPPLY CO., Cleveland, Ohio.  
Wm. Wharton, Jr., & Co. (Incorporated), 25th st. and Washington ave., Philadelphia, Pa.

**TRUCK CASTINGS.**  
ANDREWS, FRANK H., 545 W. 33rd st., New York (vide Brakes).  
Ayers, Abraham, 502 to 518 W. 45th st., New York.  
BALTIMORE CAR WHEEL CO. (The), Baltimore, Md. (vide Car Wheels).  
BOWLER & CO., Cleveland, O.  
Chester Steel Castings Co., 407 Library st., Philadelphia.  
Craig, Wm. F., 95 Liberty st., New York.  
FULTON FOUNDRY, Cleveland, Ohio (vide Axes).  
Haines Bros., 55 Broadway, New York.  
HATHAWAY & ROBINSON, 14 Case Bldg., Cleveland, O.  
HOLACIE A. KEEFER CO. (The), Kansas City, Mo.  
HOWARD, CHILDS & CO., Hamilton Bldg., Pittsburgh.  
JOHNSON STEEL STREET RAIL CO. (The), Johnstown, Pa. (vide Hubs Steel).  
LEWIS & FOWLER MFG. CO. (The), 27 Walworth st., Brooklyn, N. Y.  
Metallic Street Railway Supply Co., Albany, N. Y. (vide Hubs Steel).  
Meyensburg, O. W., & Co., 204 N. 3d st., St. Louis, Mo. (Branch—Phenix Bldg., Chicago, Ill.)  
Phenix Steel Wire, Brown & Brush Co., 199 E. Randolph st., Chicago, Ill.  
PUGH & RUSSELL, Stewart Bldg., New York; Phenix Bldg., Chicago, Ill.  
St. Thomas Car Wheel Co., St. Thomas, Ont., Canada.  
SNEAD & BIBB, Louisville, Ky.  
WAY FOUNDRY CO. (The), 23rd and Wood sts., Philadelphia, Pa.  
Wm. Wharton, Jr., & Co. (Incorporated), 25th st. and Washington ave., Philadelphia, Pa.  
Whiting Mfg. Co., Cedar Rapids, Iowa.  
WHITNEY, A., & SONS, Philadelphia, Pa.

**TRUCK SCRAPERS.**  
ANDREWS, FRANK H., 545 W. 33rd st., New York (vide Brakes).  
Bell (J. G.) Co., Philadelphia.  
Craig, Wm. F., 95 Liberty st., New York.  
Augustus 22 Park Place, Detroit, Mich.  
Greely, The E. S., & Co., 5 and 7 Dey st., New York.  
JOHNSON, TOM L., Indianapolis, Ind.  
Lactec Car Co., 4500 N. Second st., St. Louis, Mo.  
Litch, H. H., Louisville, Ky.  
Phoenix Steel Wire Brown & Brush Co., 199 E. Randolph st., Chicago, Ill.  
PUGH & RUSSELL, Stewart Bldg., New York; Phenix Bldg., Chicago, Ill.  
STREET RAILWAY SUPPLY CO., Cleveland, Ohio.  
Van Dorn Iron Works, Cleveland, O.

**TRUCK SWEEPERS.**  
ANDREWS, FRANK H., 545 W. 33rd st., New York (vide Brakes).  
Bell (J. G.) Co., Philadelphia.  
BROOKLYN RAILWAY SUPPLY CO. (The), 41 Walworth st., Brooklyn, N. Y.  
Craig, Wm. F., 95 Liberty st., New York.  
Greely, The E. S., & Co., 5 and 7 Dey st., New York.  
Haines Bros., 55 Broadway, New York.  
LEWIS & FOWLER MFG. CO. (The), 27 to 35 Walworth st., Brooklyn, N. Y.  
MARTIN, RUFUS, & CO., 13 Park Row, New York.  
Phenix Steel Wire Brown & Brush Co., 199 E. Randolph st., Chicago, Ill.  
Post & Company, Cincinnati, Ohio.  
PUGH & RUSSELL, Stewart Bldg., New York; Phenix Bldg., Chicago, Ill.

**TRANSFER TABLES.**  
Bell (J. G.) Co., Philadelphia.  
Craig, Wm. F., 95 Liberty st., New York.  
FULTON FOUNDRY, Cleveland, Ohio (vide Axes).  
Haines Bros., 55 Broadway, New York.  
HATHAWAY & ROBINSON, 14 Case Bldg., Cleveland, O.  
HOWARD, CHILDS & CO. (The), Kansas City, Mo.  
LEWIS & FOWLER MFG. CO. (The), 27 to 35 Walworth st., Brooklyn, N. Y.  
PUGH & RUSSELL, Stewart Bldg., New York; Phenix Bldg., Chicago, Ill.

STREET RAILWAY SUPPLY CO., Cleveland, Ohio.  
Wm. Wharton, Jr., & Co. (Incorporated), 25th st. and Washington ave., Philadelphia, Pa.

**TRANSIT.**  
ALOR, A. S., & CO., 300 N. Fourth st., St. Louis, Mo.  
**TURN OUTS.**  
ANDREWS, FRANK H., 545 W. 33rd st., New York (vide Brakes).  
Craig, Wm. F., 95 Liberty st., New York.  
FULTON FOUNDRY, Cleveland, O. (vide Axes).  
Haines Bros., 55 Broadway, New York.  
HOLACIE A. KEEFER CO. (The), Kansas City, Mo.  
JOHNSON STEEL STREET RAIL CO. (The), Johnstown, Pa. (vide Hubs Steel).  
LEWIS & FOWLER MFG. CO. (The), 27 to 35 Walworth st., Brooklyn, N. Y.  
Metallic St. Railway Supply Co., Albany, N. Y. (vide Hubs Steel).  
Meyensburg, O. W., & Co., 204 N. 3d st., St. Louis, Mo. (Branch—Phenix Bldg., Chicago, Ill.)  
PUGH & RUSSELL, Stewart Bldg., New York; Phenix Bldg., Chicago, Ill.  
St. Thomas Car Wheel Co., St. Thomas, Ont., Canada.  
STREET RAILWAY SUPPLY CO., Cleveland, Ohio.  
WAY FOUNDRY CO. (The), 23rd and Wood sts., Philadelphia, Pa.  
Wm. Wharton, Jr., & Co. (Incorporated), 25th st. and Washington ave., Philadelphia, Pa.

**TURN TABLES.**  
ANDREWS, FRANK H., 545 W. 33rd st., New York (vide Brakes).  
Ayers, Abraham, 502 to 518 W. 45th st., New York.  
Bell (J. G.) Co., Philadelphia.  
Craig, Wm. F., 95 Liberty st., New York.  
FULTON FOUNDRY, Cleveland, O. (vide Axes).  
Greely, The E. S., & Co., 5 and 7 Dey st., New York.  
Haines Bros., 55 Broadway, New York.  
HATHAWAY & ROBINSON, 14 Case Bldg., Cleveland, O.  
HOLACIE A. KEEFER CO. (The), Kansas City, Mo.  
JOHNSON STEEL STREET RAIL CO. (The), Johnstown, Pa. (vide Hubs Steel).  
Kaesner Chas. & Co., 303 S. Canal st., Chicago.  
LEWIS & FOWLER MFG. CO. (The), 27 to 35 Walworth st., Brooklyn, N. Y.  
Metallic St. Ry. Supply Co., Albany, N. Y. (vide Cable Vokes).  
PUGH & RUSSELL, Stewart Bldg., New York; Phenix Bldg., Chicago, Ill.  
SNEAD & BIBB, Louisville, Ky.  
STREET RAILWAY SUPPLY CO., Cleveland, Ohio.  
Wm. Wharton, Jr., & Co. (Incorporated), 25th st. and Washington ave., Philadelphia, Pa.

**TYPE WRITERS (and Supplies).**  
WYCKOFF, SEARS & ROBINSON, (Hemington Standard Type Writer), 195 LaSalle st., Chicago.

**UPHOLSTERY, MATS, ETC.**  
BEADLE, EDWARD R., 1193 Broadway, New York (vide Folding Mats).  
Evert, W. L., New Haven, Conn.  
Gould, J. & Sons, Pawtucket, R. I. (Mohair Plush).  
Gould J. H. & Gould & Co., Philadelphia (vide Grips).  
Hays & Kluha Mfg Co. (The), 48 and 50 N. 6th st., Philadelphia.  
HARTFORD WOVEN WIRE MATTRESS CO. (The), 101 E. 30th St., New York.  
Lynn & Peth, 707 Market st., Philadelphia, Pa.  
MARTIN, RUFUS, & CO., 13 Park Row, New York.  
Warcock & Taylor, 211 E. 22nd st., New York (vide Folding Mats).

**VARNISHES.**  
Babcock, John, & Co., 2 Liberty sq., Boston, Mass.  
Bell (J. G.) Co., Philadelphia.  
BRADY & WIGHT CAR CO. 2300 Broadway, St. Louis, Mo.  
COFFIN, DEVOE & CO., 176 Randolph st., Chicago, Ill.  
Gidd & W. G., New York.  
Greely, The E. S., & Co., 5 and 7 Dey st., New York.  
MARTIN, RUFUS, & CO., 13 Park Row, New York.  
Murray & Co., 241 Mulberry st., Newark, N. J. (Branches—227 Broadway, New York; 566 Canal st., Cleveland, O.; 262 Washab av., Chicago; 300 S. 4th st., St. Louis, Mo.)  
Parrott Varnish Co., Bridgeport, Conn.  
Fomeroy & Fischer, 30 Frankfort st., New York.  
Post & Company, Cincinnati, Ohio.  
PUGH & RUSSELL, Stewart Bldg., New York; Phenix Bldg., Chicago, Ill.  
Sherwin-Williams Co. (The), Cleveland, O.  
Shipman & Bolen, Newark, N. J.  
STREET RAILWAY SUPPLY CO., Cleveland, Ohio.  
Valentine & Co., 645 Broadway, New York (vide Paints).

**VETERINARY SUPPLIES, Etc.**  
Arnheim, D., 52 Second av., Pittsburgh, Pa.  
Humphrey's Homeopathic Medicine Co., 109 Fulton st., New York.  
PUGH & RUSSELL, Stewart Bldg., New York; Phenix Bldg., Chicago, Ill.  
Rohrer & Co., 741 Broadway, New York.  
SOMERVILLE, DE. W.M., & SONS, 127 Erie st., Buffalo.  
Vacuum Oil Co., Rochester, N. Y. (vide Oils).  
Williams (Lawrence) & Co., Cleveland, Ohio.

**WELDING DIES (for Sharp) Calks.**  
Borker, P. F., 360 Dorchester av., Boston, Mass. (vide Toe Calks.)  
**WINDING WASHERS.** Car.  
Phenix Steel Wire Brown and Brush Co., 199 E. Randolph st., Chicago, Ill.

**WIRE AND WIRE ROPES.**  
Broderick & Barcom Wire Rope Co., St. Louis, Mo.  
Bullivant & Co., 72 Mark Lane, London, E. C.  
Cable Railway Co., 329 Market st., San Francisco, Cal.  
REIDINGERS ROPE CO. JOHN A. TRENTON, N. J. (Branches—117 and 119 Liberty st., New York; 171 and 173 LaSalle st., Chicago; 14 Drum st., San Francisco, Cal.)

**WOOD FILTERS.**  
CHICAGO WOOD FINISHING CO., 143 and 145 E. Clinton st., Chicago, Ill.  
**WOOD SUPPLIES (for Cars).**  
KUHLMANN CAR CO., 490 St. Clair st., Cleveland, O.

**Base Hits.—Great Game.**  
(Continued from GAZETTE.)

A howl went up when President Robison trotted up with a telegraph pole for a bat. ("Wire you laughing?" said he.)  
The National Car Builders was ably represented by the omnipresent John Reynolds.

At the banquet the genial toastmaster (our old friend Chas. Hathaway) tried to work off his old chestnut about "only having made one speech in his life," etc., but it wouldn't go down with the boys. As he couldn't justify an *alibi* he had to respond—and did it well.

As a raconteur F. de H. Robison has no equal.

Stanley's magnificent catch elicited generous applause, and turned the tide in favor of the St. RR. men.

The picturesqueness of the costumes was only exceeded by their infinite variety.

"Time!" cried Mr. Hathaway, when the ball landed in his watch pocket.

Upon general principles, Marshall was deaf to everything except "Take your base."

The Press Club accepted its defeat well, and promptly challenged their opponents to a return match, coupling therewith an invitation to a dinner after the game. Unanimously approved and accepted, conditional upon the two teams having a Dutch lunch together before playing, at a certain well known brewery.

A. G. Hathaway played well, and came in on a home run like a deer. (The ladies on the grand stand did not spell it that way, though.)

Innings.....I 2 3 4 5 6 7 8 9  
Press Club.....7 1 5 2 1 2 4 3 2—27  
Ry. Officials..4 0 4 1 7 9 5 1 8—31  
Home runs—Foster and Hathaway.

ENCORE.

**P. F. BURKE,**  
Successor to C. F. DEWICK & CO.,  
Manufacturer of  
**Patent Steel Shoe Calks,**  
BLUNT AND SHARP.  
WELDING DIES FOR SHARP, AND HORSE SHOERS' FOOT VISES.  
**360 Dorchester Avenue, BOSTON.**  
For Sale by Iron, Steel and Heavy Hardware Dealers. Send for Circulars.



J. MURRAY MITCHELL, President.

KARIMCK RIGGS, Treasurer.

HENRY S. ISLEIN, Secretary and Manager.

J. MURRAY MITCHELL, (DICKERSON & DICKERSON) Counsel.

# SAFETY ELECTRIC RAILWAY AND POWER COMPANY. (DAFT SYSTEM.) ELECTRIC RAILWAY MOTORS Electric Light and Power Machines. Electrical Conductors.

We are prepared to build and equip Railways with our Electric System and supply

## LIGHT —AND— POWER

Machines at the shortest notice.

Complete installation of Central Stations for the distribution of Power a specialty.

Cars equipped with the

## DAFT Electric System

can be lighted with the same current that operates the Motor.



DAFT ELECTRIC RAILWAY AT ORANGE, N. J.

From the *Los Angeles Illustrated Herald*, March, 1887.  
The Los Angeles Electric Railway is a corporation organized for the purpose of constructing and operating electric railways in the City of Los Angeles.

The Los Angeles Electric Road is undoubtedly the most successful electric road in the United States. Col. Howard secured the benefit of the working of other roads and adopted the best improvements that experience could suggest. The speed of the road is usually from 10 to 12 miles per hour, as fast as is deemed safe for the streets of the city. The apparatus is under the most perfect control, and can be stopped on the instant, and if necessary, be reversed in motion. Cars have been run at times at a speed of 20 miles per hour.

The road has been running nearly two months and not falled a single day. It has carried in a single afternoon on three cars, a distance of three miles, fifteen hundred passengers.

The Electric Railway Company has now in operation three miles of electric railway on Pico Street, and are building two miles more to reach the Plaza.

The cost of construction is about one-third of a cable road. The cost of maintenance about 60 per cent of a cable road. Its speed can be made greater. The cost of running an electric road can be estimated at one-half of a horse road, and its capacity four fold greater.

This road is one of the many enterprises that Los Angeles contributes to astonish the visitor, and is daily visited by hundreds of our sojourners.

From the *Los Angeles Times*, March 5, 1887.

## THE ELECTRIC ROAD. A FLATTERING OPINION.

H. C. Moore, Prosecuting Attorney of San Jose, and prominently connected with street railroads in that city and San Francisco, has been here for several days on business—with which he has contracted to mingle considerable pleasure. Mr. Moore is one of the owners of the horse-car system in San Jose—the system embracing about five miles of track, and an investment of about a quarter of a million dollars. The franchise of the company runs out in a year, and the company has applied for a renewal with the privilege of turning the system into an electric road.

To find out the exact facts in the case, Mr. Moore came down here to see for himself. He has examined the Pico Street electric road thoroughly, ridden over it, and is surprised and delighted with it.

After a couple of days' chase, a *Times* representative caught Mr. Moore yesterday, and had a short conversation with him on the subject of his visit. Mr. Moore said: "We heard about your electrical road; I came down and see it for myself, and am surprised at the success and smoothness of your road. I have ridden over it, and must say it is the smoothest riding road I ever rode on. You actually cannot tell, unless you watch some stationary object, just when you start and when you stop. It address all communications to

**SAFETY ELECTRIC RAILWAY AND POWER CO.**  
Office, 41 & 43 WALL ST., NEW YORK. Factory, GREENVILLE, N. J.

Estimates,  
Catalogues,  
and any information furnished on application.

We guarantee the successful operation of our system.

## Heaviest Grades

NO OBSTACLE.

On receipt of full particulars, we will send you exact estimate of the cost of equipment and operation under

## Our System.

We have the only absolutely self-regulating Motor in the World.

is a wonderful thing. Now, the Market Street road in San Francisco is the finest cable road on earth. It cost hundreds of thousands of dollars a mile. Your electric road is built very cheaply on an ungraded street whose soil is like ashes when dry, and like mortar when wet; and still, for comfort and smoothness, it is perfection. It is as much ahead of the Market Street cable road as the Market Street road is ahead of a horse railroad. I am more than satisfied with its workings.

From the *Electrical World*, March 26, 1887.

The Daft road, at Los Angeles, is working admirably. The road carried 14,952 passengers during February, and is developing a large and rapidly growing business. It is proposed to adopt the system for a road at San Jose, using a simple form of conduit system. Mr. H. C. Moore, one of the large owners of the San Jose road, which has hitherto been run by horses, inspected the Los Angeles road recently and pronounced a strongly favorable opinion on its merits.

BALTIMORE, Sept. 25, 1886.

SAFETY ELECTRIC RAILWAY AND POWER CO., NEW YORK.  
*Cordlemen*—In answer to yours of the 23d inst., making inquiries in relation to the Baltimore & Hampden Electric Railroad, I have to say that its success by the change from horse and mule power to electric power under the Daft System has exceeded my highest expectations. It has largely increased the travel on the route, and at a less operating expense than horse power. The road has been running more than a year by electricity with as much regularity as any road in the country. I find less difficulty in getting men to run the motors properly than I do to get men to run the ordinary horse car properly. The road is now being run by persons who before their employment here were unfamiliar with electrical affairs.

T. C. ROBBINS, GENERAL MANAGER.

REPORT OF T. C. ROBBINS, Esq., Manager of Baltimore Union Passenger R. R. Company, showing results of running the Baltimore & Hampden Road by DAFT ELECTRIC MOTORS.

In the year ending September 1st, 1885, with horses, at a speed of 4.033 miles per hour:	In the year ending September 1st, 1886, with Electricity, at a speed of 8 miles per hour:
Passengers carried were..... 327,155	Passengers carried were..... 311,141
Gross Earnings were..... \$1,357.75	Gross Earnings were..... \$1,537.05
Cost of Motive Power was..... 7,117.50	Cost of Motive Power was..... 4,330.00
Cost of Motive Power per Passenger per mile was..... .0156	Cost of Motive Power per Passenger per mile was..... .007

- I. An Increase in Traffic of..... 37 per cent nearly
- II. A Reduction in Cost of Motive Power in Gross of..... 35 per cent.
- III. A Reduction in Cost of Motive Power in Gross per Passenger per mile of..... 55 per cent.



# DIRECTORY SUPPLEMENT.

# The Street Railway Gazette.

VOL. II.

CHICAGO.

OCTOBER, 1887.

NEW YORK.

No. 10.

## The Reliable Sand Box.

OVER 500 NOW IN USE. AUTOMATIC, SIMPLE AND EFFECTIVE.

W. T. BUTLER, ESQ.,

*Dear Sir:*—We used eight of your Reliable Sand Boxes last winter and found them very serviceable. We have now several miles of track over the hills of Haverhill and West Newbury, and they are of great assistance to us, not only for sanding, but also for distributing salt (on such parts of the road as the city government will allow). We can recommend them to any Horse Railway Company, especially to those who have hills to operate.

Haverhill, September 23, 1887.

Your truly,

JOHN A. COLBY, Treasurer, Haverhill and Groveland Street Railway Company.

W. T. BUTLER, General Manager,

19 Tremont Row,

BOSTON, MASS.

## THE BRYDEN FORGED HORSE-SHOE WORKS, LIMITED.

CATASAUQUA, PENN.

MANUFACTURERS OF

## The Bryden Forged Solid Calk HORSE AND MULE SHOE.

ADOPTED BY THE FOLLOWING STREET RAILWAYS :

*The Third Avenue R. R. Co., Eighth Avenue R. R. Co., Broadway & Seventh Avenue R. R. Co., of New York City; Bushwick R. R. Co., Brooklyn City and Newton R. R. Co., of Brooklyn; Philadelphia Traction Co., Citizen's Passenger R. R. Co., Second & Third Street R. R. Co., of Philadelphia; Metropolitan R. R. Co. of Washington, D. C.; North Chicago R. R. Co., Chicago City R. R. Co., West Division R. R. Co., of Chicago, Ill.; New Orleans City & Lake R.R., Co., of New Orleans, La., etc. etc.*

J. B. WHITE, MANAGER SALES DEPARTMENT,

234 Lake Street, CHICAGO, ILLS.

# KUHLMANN CAR CO.

BUILDER OF

# STREET RAILWAY CARS

OF EVERY DESCRIPTION.

ALL KINDS OF WOOD WORK FOR INTERIORS A SPECIALTY.

Street Railway Companies building their own Cars will do well to correspond with us.

Office: 490 St. Clair Street, CLEVELAND, O.

## CLEVELAND FOUNDRY,

MANUFACTURERS OF

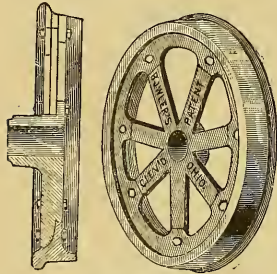

### Car and Locomotive Wheels,

*Either Chilled or Steel Tired, with or without axles.*

*Street Railway Wheels, Turnouts and Turntables, Patent Chilled Face R. R. Frogs, Engine and Heavy Castings a Specialty.*

**GRADED STABLE CUTTERS WITH STRAIGHT OR CURVED COVER.**

Descent 1/2 inch per foot. Pieces 5 feet lengths. Short pieces furnished to suit any length. Spouts to connect with sewer.

They control and make N. P. Bowler's Patent Street Railway Wheel. The tire of this wheel is cast separately from the hub and spokes; the latter is made of soft strong iron, and is perfectly free from strain—therefore can be made much lighter and more durable. The tires and the spokes or center of the wheel are made perfectly interchangeable so that when the tire or rim is worn out another can be put in its place by any employee with no other tool than a common wrench.

**BOWLER & CO., 10 to 24 Winter St., CLEVELAND, OHIO.**

# Use IRON CLAD PAINT FOR YOUR CARS, BARNs AND BUILDINGS.

OFFICE OF EAST CLEVELAND RAILWAY CO.  
IRON CLAD PAINT Co.  
*Gentlemen:*—This Company, for the last 17 years, has extensively used your "Iron Clad Paint" upon its buildings, roofs and cars. For durability, protection against fire, and cheapness, there is no paint that will compare with it. It is equally as good for floors as for coarse work; it polishes beautifully. The paint upon the bodies of our cars which was put on ten years ago, is as firm and good as when first put on, while the other kinds of paint put on at the same time, has been renewed twice; nothing has been done to the Iron Clad except new coats of varnish.  
EDWIN DUTY, Superintendent.  
WM. KRUEGER, Painter.

OFFICE OF THE MASTER CAR BUILDER,  
Toledo, Wabash & Western Ry.  
TOLEDO, O., Feb. 18, 1875.  
IRON CLAD PAINT Co., Cleveland, O.  
*Dear Sir:*—In reply to your letter of the 9th inst., as to the use of the "Iron Clad Paint" by this Company, would say: That we have been using it for the past year on our passenger and baggage cars, and are very much pleased with it. We can cheerfully recommend it for its body, durability and cheapness. Accompanying this you will find a sample of the color we use on our coaches, which is obtained by grinding together 20 pounds of Rosie and one pound Lampblack.  
Respectfully,  
U. H. KOHLER, M. C. B.

THE  
**PUREST.**  
THE MOST  
**FIRE-PROOF.**  
THE MOST  
**DURABLE**  
**PAINT**  
IN THE  
**WORLD.**

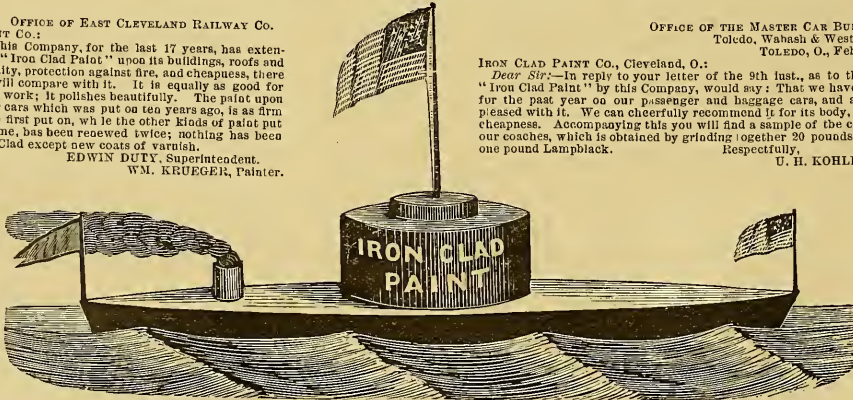

THE  
**Cheapest.**  
THE MOST  
**Economical.**  
THE MOST  
**Water-Proof**  
**PAINT**  
IN THE  
**WORLD.**

Trade Mark Patented—Paint Patent'd.

Refer to East Cleveland Street Railway Company, who have used it for nearly Twenty Years.

## IRON CLAD PAINT COMPANY, - CLEVELAND, OHIO.

A Discount of 5 per cent to any one mentioning this Advertisement,



### "Boston Wants Them Too."

Elevated roads are merely a temporary expedient. They compel a sacrifice of the public comfort to the public necessity. We must get up town at all hazards, and after the rush of business the surface cars drive us wild. They are a funeral means of progress. So we pack ourselves in these sardine boxes upon stilts and trust in Providence. All the while we have a feeling that Providence will go back on us some day for our folly, and then we will wish there were four solid tracks underground. And we ought to have them. The time is ripe for them. They will pay, and pay well. When we get them, we shall wonder how in the world we ever lived without them, and why we were such fools as to delay the matter so long. So says the *New York Herald*, under the same caption as appears at the head of this article.

The difference in the plan and general arrangement of the two cities—New York and Boston—is very marked. New York has, comparatively speaking, straight streets, such as Broadway and the avenues parallel to it; Boston's main street, Washington street, is far from being in a straight line, and Tremont, Devonshire, Congress and other central business streets, are neither parallel to Washington street, nor extend in a straight line.

Again, New York has one grand central steam railroad depot. The direction of the main travel, to and fro, is in a longitudinal direction, from Harlem to South Ferry, and is in a transverse direction from the East to the North rivers. Boston has several steam railroad depots, in different parts of the city. Among these are the Boston & Providence R. R.; Boston & Albany R. R.; Old Colony R. R.; Boston & Lowell R. R.; New York & New England R. R.; Boston & Maine R. R.; Fitchburg and Eastern railroads. The suburbs of Boston can be reached by these railroads. A very great number of business men and working men and women, whose daily occupation is in Boston, live out of Boston, in places like Hyde Park, Jamaica Plains, Roxbury, Brookline, Brighton, Dorchester, Cambridge, Charlestown, Newton, Lynn, and fifty other pleasant and quiet localities. They are conveyed rapidly and regularly on these roads, as well as by horse-cars. The business center of Boston is filled and emptied every day. There is no lack of facilities for getting out of or into the city. The trouble is in the city proper; and there, the erection of elevated railroads over many of the streets would not ameliorate the condition of affairs. Boston does not want elevated railroads, and when there are so many horse-railways in the city, and so many steam roads leading out of the city, we fail to recognize the necessity of constructing what are "temporary expedients." Tunneling Boston!—Don't mention it. Yet, what can be done?

The great difficulty with the "Hub" is the narrowness of its crowded central streets. Take, for instance, Washington street as it is now; a narrow street at best, with narrow sidewalks; and yet on this street are the largest and handsomest and most attractive retail stores. It is a central street, a long part of which is narrow and cramped, crowded with omnibuses and horse-cars, with wagons and vehicles from a hand-cart up, with boxes and bales of goods, with floods of moving humanity. Now, in the language of the late illustrious Tweed, "What are you going to do about it?" What *can* be done with such a narrow, yet popular, wealthy, attractive street? To construct an elevated railroad here would be foolish, and would kill the street. To tunnel it, would be a too long and too expensive operation, and would prove to be, eventually, of little account, as business is pushing away from it. What can be done now? that is the question. Can anything be done, or is the street to be regarded as an inconvenient drawback for which there is no remedy?

Since writing the above, many letters and petitions from various citizens complaining of the nuisance caused by digging up the streets, have been forwarded to the mayor of Boston, who laid them before the several commissioners. Among the explanations put in there is one from John W. McDonald, superintendent of streets, which, as it corroborates what has been said, will be read with interest; and

especially that part of his letter which refers to the "only remedy."

Not only have the pedestrians and truckmen been greatly inconvenienced but some of the street railway companies have also been obliged to alter the usual route of travel, on account of the impassability of the streets.

Hon. Hugh O'Brien, Mayor:

DEAR SIR—In reply to your communication I beg leave to say that the various companies now at work on the streets are doing their work as well as such work can be done; the inspection is sufficient and in competent hands; every request of this department to repair has been immediately attended to and all the companies have signified their willingness to do everything necessary, but every attention on their part and on ours will not keep our streets in good order when they are being dug up almost daily.

Assuming that all the pipes now laid in the streets as well as those to be laid are needed by the public, then it is obvious that, under the orders of the Board of Aldermen, it is the duty of this department to issue permits (unless forbidden to do so by your honor), and to see that the street is restored as well as it can be. But it must be remembered that this pipe laying is for the purpose of furnishing light, heat, water, drainage or something to the abutting houses, and the pipes laid across the street to each and every house with the necessary repairs in all these will for a long time to come keep the streets in very bad order, and yet there is no neglect on the part of anybody.

It is my opinion that this pipe-laying should be done with the most expedition possible that will not interfere with general traffic. As this is the slack season for business, it is the intention of this department, with your honor's approval, to issue no permits after Nov. 1 until April 1, in order that the streets in which trenches have been dug may be made safe for the winter.

The network of pipes under our streets, if uncovered, would be a surprise to most people, and everybody would think that to bury these in the ground would be as absurd as to fill in the interior of a factory with earth leaving the machinery to work in pipes.

In fact the only remedy is to build subways, containing all these conduits, leaving the surface in its proper condition.

I believe it to be detrimental to the interests of the city to grant, without compensation, to private companies, the right to occupy the streets, as I believe the streets cannot be restored to as good condition as before opening.

(Signed)

JOHN W. McDONALD,  
Superintendent of Streets.

Pertinent to this subject a correspondent writes to the *Boston Herald*: In view of the ruthless manner in which the streets of our city are torn up for the purpose of supplying the citizens with sufficient water, gas and electricity for our daily wants, would it not be well for our city fathers to take into consideration the feasibility of constructing tunnels under all the roadbeds of streets on which the principal traffic is done, in which all these pipes can be placed, repaired from time to time, etc., without in the least incommoding or obstructing travel on the roadbed? Our city is so conveniently situated within a short distance of inexhaustible hills of granite that this work might be carried on continuously, and at comparatively small expense.

The granite could be gotten out by the criminals in our jails, instead of using their labor in competition with the honest laborer, as is now the case, and the city and honest labor would both be benefited. I heard one of the board of a public institution remark within a few days that "our criminals were better clothed, better lodged and better fed than any other class of laborers in the state," and as I have no reason to doubt this statement, would it not be well to bring this stalwart element into a position whereby the whole community will be benefited, instead of this class being a burden. The streets are becoming more crowded every year, and it seems to me that something should be done to relieve any and all obstruction to travel and traffic by this constant excavation, and the only course left is to

build large, substantial tunnels for the roadbed to rest upon, and into which all the systems of pipe can be projected.

The latest pipes laid are those for super-heated water. And in face of the continual tearing up processes that are going on—coupled with the other reasons stated—we are fully justified in advocating "depressed railways," although we are confronted by a crowd of various pipes as soon as the cobble stones are taken up. But if there is any remedy for Boston's crowded streets, that remedy will be found in depressed railroads. Yes, if New York wants them—Boston wants them too.

We publish in another place an ordinance passed by the city council of Pratt, Kansas, granting franchises to the City Street Railway Company, who proposes to build and operate a street railway in the city of Pratt. The railway company have examined the ordinance and signified their willingness to accept its provisions. They have, however, ten days from its publication to make a formal acceptance, ten days thereafter to commence work, and ninety days to complete building of the road on Main street from the Santa Fe to the Rock Island depot. That work is to be done rapidly enough. Thirty days after the completion on the Main street line work shall be commenced on three branch lines; one half mile east on 4th street, one half mile west on 1st street and one half mile north on Main street north of the Rock Island depot, said branch lines to be completed within ninety days from the time of commencing work thereon. The company is composed mostly of foreign capitalists, and, we understand, have the material is already on hand for the construction of the road. The spirit of system progress is at Pratt, evidently.

"OLD TOPEKA, in the shape of the antideluvian horse cars, is passing away," says a local newspaper scribe, "while new Topeka, as represented by the spacious Rapid Transit cars, is coming to the front. Who will regret the extinction of old foggysim, when the liberal ideas of the present hour bring such superior comfort and economy of time?" Let some one else give the Topeka City Railway cars a word of encouragement. This is all the more necessary—to serve the one as well as the other—when we find another scribe making a direct attack on the City cars. These are the two companies whose "war" was mentioned in the September GAZETTE, and evidently these scribes are prejudiced in favor of the Rapid Transit cars. And this is the way the latter scribe shows his partiality: "A Rapid Transit train consisting of two coaches, brilliantly lighted and loaded with passengers, was approaching from the north, while another similar train, likewise well filled, was preparing to start north from the station at Eleventh and Jackson streets. On came the south-bound train, gliding like a thing of beauty over the rails, while as it drew near the Tenth street crossing the ruddy light cast by the headlight of the engine exceeded in brilliancy that furnished by the electric tower." That is strong praise certainly, but he goes on to make a contrast, saying: "Coming east on the City railway on Tenth street, less than a rod away, was a single car drawn by a pair of jaded, scraggy-looking mules who seemed scarcely equal to the task of standing up on the track, much less to that of propelling the car which contained one listless, sleepy-appearing passenger. The attenuated, sorry-looking team, scarcely waiting for the word of command from the half-napping driver, came to a halt; the Methuselah appearing ark behind them gave a lurch over an inequality in the track before settling down as a lifeless thing, while the brilliantly lighted Rapid Transit cars, with their animated human freight, rolled noiselessly over the track."

THE statements of Mr. Ries, which we have excerpted, may convey a fair idea of this electrician's novel and interesting theories. The paper read at New York was illustrated and created considerable stir, so much so that a special exhibition of the apparatus was given for the benefit of members and others who were unable to attend the reading of the paper. And extensive extracts therefrom have appeared in several electric and railroad publications.

## Business Notes.

THE Car Track Friction Appliance Company has received orders for its Reliable Sand-boxes during the last month from Lincoln, Nebraska; Seattle, Washington Territory; Scranton, Penna.; Waterbury, Conn.; New York City; Allegheny City, Pa.; Laclade Car Co., for Kansas City; Pullman Palace Car Co., for Omaha, Neb. The company's business is excellent and is rapidly increasing.

E. P. ALLIS & Co., Reliance Works, Milwaukee, Wis., are constructing a pair of engines with 32"x48" cylinders for the Grand Avenue Cable R.R., Kansas City, Mo.

THE Empire Warehouse Co., 198-210 Market street, Chicago, are the general agents for the Portland Cement, and importers of English and German Portland cement. They have supplied the cement used by the Chicago City Railway Co.; also to the Kansas City Cable Ry. Co., Metropolitan (cable) Street Railway Co., and Grand Ave. (cable) Ry. Co., all of Kansas City, Mo.; together with the Citizens' (cable) Ry. Co., and the Missouri R.R. Co., St. Louis, Mo.

THE Van Depoele Electric Railway and Power Co. has been incorporated at Chicago, with \$2,000,000 capital, to undertake the electric railways department of the Van Depoele Electric Manufg. Co. so that the latter firm may devote itself to electric lighting apparatus. As stated in the August GAZETTE the present Van Depoele premises are too small for their extensive operations, and the division of the work as now contemplated is a much felt want.

## Patents.

The following list of recent Patents relating to Inter-mural traffic is specially reported for THE STREET RAILWAY GAZETTE by Wm. H. Henderson, Solicitor of American and Foreign Patents, 925 F Street, Washington, D. C. A copy of any of the following will be furnished by him for 25 cents.

*Issued during September 1887.*

- 357,455. Railway car brake—J. L. Brown, Rahway, N. J.
- 357,316. Railway rail—R. L. Harris, Brooklyn, N. Y.
- 368,834. Construction of tunnels for cable railways—J. Johnson, New York.
- 369,275. Cable car signal—A. E. Cross, St. Louis, Mo.
- 369,004. Car starter—M. G. Hubbard, Philadelphia, Pa.
- 369,116. Car starter—D. Lynch, Minerva, N. Y.
- 369,129. Car step—L. W. Sheldon, New York.
- 369,190. Rail for street railways—H. H. Littell, Louisville, Ky.
- 369,610. Power driven street car—J. Noble, St. Louis, Mo.
- 369,398. Street railway rails—D. C. Cregier, Chicago, Ill.
- 369,397. Street railway—D. C. Cregier, Chicago, Ill.
- 369,527. Railway turntable lock—W. H. Inloes, W. D. Justice, and C. F. Christopher, Asheville, N. C.
- 369,355. Endless railway system—L. Goddu, Winchester, Mass.
- 369,743. Heating apparatus for street cars—J. M. Segraves, Chicago, Ill.
- 369,858. Railway rail—S. M. Jacobs, New York
- 369,704. Railway rail joint—B. Franklin, Bradford, Pa.
- 370,283. Under ground conduit for electric and other railways—E. E. Ries, Baltimore, Md.
- 367,603. Car seat—J. A. Brill, Philadelphia, Pa.
- 370,602. Gong or bell for street railway cars—J. A. Brill, Philadelphia.
- 370,451. Railway wheel—T. R. Crampton, Westminster, England.
- 370,490. Differential gear for cable railways—J. P. Noyes, Binghamton, N. Y.

Experiments have been made to light the British 'buses with electricity. The 'bus, over there, has a dark inside; and with the promised light, it would be well if the time-honored vehicle was constructed on some improved model so as to provide more room also inside.

Smoking has been completely forbidden on any part of Cincinnati's horse cars.



# OFFICIAL DIRECTORY

OF THE

## STREET RAILWAYS (OR TRAMWAYS)

The United States, Canada, Mexico, South America; Great Britain, Ireland; Germany, France, Austria, Switzerland, Belgium, Holland; India, Australia, &c.

Compiled, from original data furnished by the companies, (and corrected monthly,) by Wm. HUGHES, Editor of THE STREET RAILWAY GAZETTE, to whom all additions and corrections should be addressed.

### The American Street Railway Association:

By THOMAS W. ACHESON, 621 N. 35th St., Philadelphia, Pa., U. S. A.  
Sec. & Tr. Wm. J. RICHARDSON, Atlantic Ave. Bldg. Co., Brooklyn, N. Y., U. S. A.

### The Tramways Institute of Great Britain and Ireland:

By ROBERT HUTCHINSON, Carlisle, Scotland.  
Sec. J. H. DUNNAN, F. C. A., 41 Colman St., E. C., London, England.

### The Street Railway Association of the State of New York:

By JOHN W. McNAMARA (Pr & Spt of The Albany Railway), Albany, N. Y.  
Sec. & Tr. Wm. J. RICHARDSON, Atlantic Ave. Bldg. Co., Brooklyn, N. Y.

### The Permanent International Tramways Union

(Union Internationale Permanente des Tramways):  
Pr H. G. MICHELLET, Les Tramways Bruxelles, Brussels, Belgium.  
Sec F. NONNENBERG, 49 rue du Vantour, Brussels, Belgium.

### Ohio (U. S. A.) State Tramway Association:

Pr D. W. STROUD, Citizens' St. Hl. Co., Springfield, Ohio.  
Sec H. A. EYKRIET, 1151 Euclid Ave., Cleveland, Ohio.

### EXPLANATIONS:

When the name of a city is incorporated in the name of a company, it is abbreviated; thus Birmingham = Bm. Also Street = St., Railway = Ry., Tramway = Tr., Railroad = RR., Passenger = Pass., Metropolitan = Met. (President) is abbreviated Pr., Vice-President, VP.; Chairman, Ch.; Director, Dir.; General Manager, G.M.; Superintendent, Spt.; Secretary, Sec.; Treasurer, Tr.; Engineer, Engr.

The figures (in parenthesis) after name of city show population according to last census, that for the United States having been taken in 1880, and those for Canada, Great Britain and Ireland, &c., in 1881. For more recent figures, dates are given.

The following prefixes denote: \* members of the American Street-Railway Association; † members of the Tramway Institute (Great Britain and Ireland); ‡ members of the Permanent International Tramways Union (President); † members of the Street Railway Association of the State of New York; and ‡ members of the Ohio State Tramway Association.

The gauge, throughout this Directory, should be understood to be the ordinary 4 feet 8 1/2 inches unless otherwise specified; g means gauge; lb, pounds weight of rail to yard; T represents T rail, and ch, centre-bearing; lbs (Italics) signify that the rails are steel; m stands for inches length of single track; i, cars; g, grip cars; h, horses; m, mules; nr, motor or motors; stn, steam. Address is given in full (street and number) after every company's name who have stated the same; and in all cases the name of company and that of city or town, together with the state, (to the United States,) is sufficient postal address.

### UNITED STATES.

#### ALABAMA.

**Anniston** (942). The Anniston St. Ry. Co.—Pr John W. Noble, Sec Wm. A. Davis, Engrs Moorhead and Blue; 3 m, 20 lb T.

**Anniston, Oxford & Oxanna St. Ry. Co.** (office at Oxanna).—Pr T. C. Hill, Sec & Tr W. S. Larned, Spt R. T. Allen; 3.25 m, 20 lb T, 4 1/2 m, 10 m.

**Birmingham** (3,078). Bm. Union St. Ry. Co.—Pr J. A. Van Hoes, Sec B. C. Scott, Spt T. S. Morton; 22 m, 16 lb T; 35 e, 12 h, 200 m.

**Bm. & Jones Valley St. Ry. Co.**—Helm Knox, conductor; 12 m, 45 lbs.

**East Lake Land Co.**—Pr Robt. Jemison, Sec & Tr S. M. Haulcy, Engr F. W. Beall; 7 m, 40 lbs T; 4 e, 3 stn nr. Operated by the Bm. Union St. Ry. Co.

**Highland Avenue and Belt RR. Co.**—Pr H. M. Caldwell, G.M. & Sec W. J. Milner, Engr J. M. Lewis, Spt R. E. Adams; 25 m, 36 and 54 lb T; 16 e, 5 stn nr. Milner Springs & Birmingham Street RR. Co. (Box 597).—Pr B. F. Moore, Sec J. E. Lantz, Spt R. D. Smith; 4 m, 35 lb.

**North Bm. St. RR. Co.**—Pr J. W. Johnston.

**Western Valley St. RR. Co.**—Pr J. C. Westbrooke, Sec W. H. Naff; 2.5 m.

**Calera** (234). The South St. Ry. Co.—2 m.

**Decatur** (1,063). Decatur Land Impt. and Furnace Co. (St. Ry.)—1.5 m.

**Eufaula** (3,836). City of Eu. St. Ry. Co.—Pr E. B. Young, Sec G. McCormick; 4 m, 20 lb; 4 e, 12 h.

**Florence** (1,259). Flo. St. RR. Co.—Pr W. B. Wood.

**Huntsville** (4,977). The North Ala. Impt. Co.—1 m.

**Mobile** (24,134). The Mobile Ry. Co.—Pr Wm. J. Duocan, Sec Tr & G.M. R. K. Warren; 24 m, 3-2 1/2 g, 30 to 60 lb T; 64 e, 3 h, 200 m.

**Dauphin & Lafayette Ry. Co.** (28 St. Francis St.).—Pr D. F. Bestor, VP. & Sec G. Y. Overall, Spt J. B. Connor; 2 m, 2-2 1/2 g, 40 lb; 10 e, 6 h, 10 m.

**Mob. & Spring Hill RR. Co.**—Pr R. K. Warren, Sec & Spt C. F. Sheldon; 6.5 m, 5-3 1/2 g, 35 to 60 lb; 10 e, 2 h, 41 m, 3 stn nr.

**Montgomery** (16,713). Capital City Electric Ry. Co.—Pr E. R. Joseph, G.M. J. A. Gabry, Sec R. E. Taylor; 12 m, 4 g, 42 lb; 20 e, 15 electric nr. (VanDepeze's) & Selma (7,529). Selma St. RR. Co.—Pr H. L. McKee, Sec J. P. Brown; 5 m, 4-9 g, 20 lb T; 7 e, 3 stn nr.

**Selma Land Impt. & Furnace Co.** (Electric St. Ry.)—Pr M. N. Nelson.

**Tuscaloosa** (1,218). Tusc. & Castle Hill St. Ry. Co.—G.M. W. Hill; 4.5 m.

**Tuscomb** (1,309). The Citizens' St. Ry. Co.—Pr F. D. McMillan, Sec E. B. Alaman; 6 m; 2 e, 1 stn nr.

#### ARKANSAS.

**Argenta** (500). Arg. & Big Rock St. RR. Co.—Prs S. Adams.

**Fort Smith** (3,099). F. S. St. Ry. Co.—Pr Sam'l McLeod, Sec Geo. T. Sparks, Spt W. Ewers; 2 m, 3-5 g, 28 lb; 5 e, 16 m.

**Helena** (3,522). The Helena Ry. Co.—Pr Quarles, Sec D. T. Hargraves.

**Hot Springs** (3,554). Hot Springs RR. Co.—Pr S. W. Fordyce, Sec C. E. Maurice; Spt J. L. Butterfield; 3 m, 4 e, 25 lb T; 11 e, 65 h.

**Little Rock** (13,128). Little Rock St. Ry. Co.—Pr Jas. R. Miller, Sec A. N. Johnson, Spt R. D. Apperson; 11 m, 4-10 e, 36 and 45 lb; 22 e, 26 h, 160 m.

**Citizens' St. Ry. Co.** Owned and operated by Little Rock St. Ry. Co.; 5 m.

**Pine Bluff** (3,309). The Citizens' St. Ry. Co.—Pr John M. Taylor, Sec John O'Connell, Spt H. Bradford; 2.25 m, 35 lbs; 6 e, 28 m.

The "Wiley Jones" St. Ry. Co.

**Searcy** (840). The Citizens' Point RR. Co.—Pr & Spt W. Yarnell, Sec Jasper Hicks; 8 m, 20 lb T; 8 e (3 pass and 6 frt), 10 m.

**Texarkana** (3,223). Tex. St. Ry. Co.—Pr C. E. Mitchell, Sec Thos. Orr, Spt B. M. Furman, Engr A. L. Stephenson; 1 m, 3 g, 16, 30 and 24 lb T; 4 e, 9 h, 6 m.

The State Line Ry. Co.—Pr E. A. Warner.

#### CALIFORNIA.

**Anaheim** (833). Anaheim St. Ry. Co.

**East Oakland** (3,500). The Citizens' St. Ry. Co.—Pr John M. Taylor, Sec W. C. Mason, Spt Jas. Dixon; 2.5 m, 5 g, 35 lb; 4 e, 25 h.

**Los Angeles** (11,183). City & Central St. Ry. Co.—Pr L.W. Hellman, Sec R. D. P. Widener, Spt Wm. Hawke; 22.5 m, 3-6 and 4-8 g; 37 e, 332 h.

**Central and Boyle Heights RR. Co.**—Pr E. F. Spence, Sec F. Harkness, Spt W. Hawke; 7 m, 3-6 g, 16 lb; 26 e, 111 h.

**Los Angeles & Boyle Heights RR. Co.**—Pr E. F. Spence, Sec F. Harkness, Spt W. Hawke; 7 m, 3-6 g, 16 lb; 26 e, 111 h.

**Los Angeles & Pacific RR. Co.** (132 N. Main St.)—Pr J. F. Crank, G.M. Chas. Forman, Sec R. D. P. Widener; 20 m, pt. 3-6 g, 20 lb; 41 e, 273 h.

**Los Angeles Electric Railway Co.** (East Station).—Pr G. H. Bonebrake, G.M. and Sec C. H. Howland; 5 m, 4-8 e, 4 e.

**Main St. & Agricultural Park RR. Co.** (10 Commercial St.)—Pr W. J. Brodick, Sec A. C. Taylor, Spt E. M. Lorrain; 10 m, 3-6 g, 16 lb T; 22 e, 80 h.

**Second St. Cable RR. Co.** (cor. 2d and Figueroa Sts.)—Pr Jas. McLaughlin, Sec H. Davis; 3.70 m, 3-6 g, 16 lb T; 6 e, 6 g, 1 stn nr. cable engine 60 hp.

**Temple St. Cable RR. Co.**—Pr P. Beauvais, Sec E. W. Wood, Spt J. Fowler; 1.63 m, 3 g, 16 lb T; 4 e, 5 ft; engine 80 hp.

**Union Pacific Rapid Transit Co.** Electric railway. (Eos System.)

**West End RR.**

**Marysville** (4,321). City Pass. RR. Co.

**Oakland** (34,557). The Oakland, Ukiah and Piedmont RR. Co.—Pr Walter B. Carr, Sec Mont. Howl; 3 m, 5 g, 30 lb; 18 e, 45 h.

**Brooklyn & Fruit Vale RR. Co.**—Pr E. C. Sessions, Sec W. W. Gill; 2.25 m, 5 g, 13 h.

**Fourteenth St. RR. Co.**—Pr Spt Walter Blair, Sec J. W. Britton; 8 m, 5 g, 25 and 38 lb; 10 e, 51 h.

**Oakland RR. Co.**—Pr J. A. Swartwout, Sec J. Y. Loring; 8 m, 3 g, 80 lb; 9 e, 85 h.

**Oakland, Brooklyn & Fruit Vale R. R. Co.**—Pr H. Tabbs, Sec W. C. Mason, Spt G. H. Mason; 2.45 m, 5 g, 35 lb; 4 e, 11 h.

**Oakland Cable Ry. Co.**—Officials same as those of Oak. RR. Co.; 5 m, 3 g, 40 lb; 10 e.

**Pasadena** (391). City Ry. Co. (P. O. Box 534).—Pr C. W. Buchanan, Spt A. J. Painter, Sec M. D. Painter; 3 m, 16, 30 and 50 lb; 4 e, 4 h, 10 m.

**Colorado St. RR. Co.** (Box 193).—Pr & Spt G. E. McHargy, Sec C. W. Sawtell, Engr J. M. Willard; 3 m, 3-6 g, 16 lb T; 3 e, 6 h.

**Highland RR. Co.**—Pr J. A. Swartwout, Sec J. B. Young, Spt C. C. Thompson; 5 m, 16 and 30 lb; 6 e, 24 h.

**Park Place RR. Co.**

**Pas. St. RR. Co.**—Pr Stephen Townsend, Sec P. G. Wooster, Spt & Engr Willliell Thompson; 3.25 m, 3-6 g, 16 lb T; 3 e, 15 h.

**Sacramento** (21,420). City Ry. Co.—Prs R. S. Crocker, Spt G. W. Carey; 23 e.

**San Diego RR. Co.**—Pr G. M. J. L. Willcutt, Sec J. L. Young, Spt C. O. Thompson; 5 m, 16 and 30 lb; 6 e, 24 h.

**San Diego** (2,637). S.D. St. Car. Co.—Pr H. L. Story, Sec H. W. Mattett, Spt C. R. Williams; 3 m, 16 and 30 lb T; 12 e.

**S.D. & National City Motor Line.**

**The Coronado Beach Co.**—Pr H. L. Story, Sec & Tr O. S. Hubbell; 4.5 m, 20 lb T; 2 m nr.

**San Francisco** (233,959). California Street Cable RR. Co. (1435 California St.)—Pr Chas. Mayne, Sec T. W. Hitchman, Spt J. W. Harris, Engr A. D. McLean; 7 m, 3-6 g, 34 lb T; 27 e, 25 g, 4 h; engine 200 hp.

**Central RR. Co.** (Fourth and Townsend Sts.)—Pr Chas. F. Crocker, Sec & G.M. J. L. Willcutt, Spt John F. Clark, Engr A. Kelly; 12 m, 5 g, 45 lb; 57 e, 293 h.

**City RR. Co.** (The).—Pr Leland Stanford, Sec & G.M. J. L. Willcutt (Fourth and Townsend Sts.), Spt H. L. Clay (1804 Mission St.); 11 m, 5 g, 45 lb; 67 e, 289 h.

**Clay Hill RR. Co.** (S.W. cor. Clay and Leavenworth Sts.)—Pr & Spt Joseph Britton, Sec Chas. F. Campbell, 2 m, 3-6 g, 30 lb; 11 e, 12 g; engines 120 hp.

**Geary St., Park & Ocean RR. Co.** (4th and Townsend Sts.)—Pr Chas. F. Crocker, Sec & G.M. J. L. Willcutt, Spt G. M. Johnson Reynolds, Engr C. F. Stout; 8 m, 5 g, 35 lb; 30 e, 26 g, 4 stn nr.

**Market St. Cable Ry. Co.**—Pr Leland Stanford, Sec & G.M. J. L. Willcutt; Spt A. W. Barron; 3 m, 3-6 g, 34 lb; 16 e, 133 e, 3 e, 86 h; 2 pair cable engines 500 hp each, 2 pair 300 lb each, and 2 pair 275 lb each.

**North Beach and Mission RR. Co.** (4th and Louis Sts.)—Pr Albert Meyer, Sec H. W. Hutton, Spt M. S. Hines; 16 m, 3 e, 45 lb; 64 e, 420 h.

**Ocean Beach Ry.**—Pr Leland Stanford, Sec J. L. Willcutt; 2 m; operated by Mt. St. Cable Ry. Co.

**OmniBus RR. & Cable Co.** (727 Howard St.).—Pr Gustav Sutro, Sec G. Ruepp, Spt M. M. Martin; 18 m, 3 g, 40 and 45 lb; 60 e, 400 lb (changing to cable).

**Park & Ocean RR. Co.**—Pr Chas. F. Crocker, Sec L. Willcutt; 4.5 m, 35 and 40 lb T; 22 e (16 pass, 6 flat and section), 7 stn nr. Operated by Market St. Cable Ry. Co.

**Potrero & H. View RR. Co.**—Pr Leland Stanford, Sec & G.M. J. L. Willcutt, Spt H. O. Rogers; 3.22 m, 5 g, 35 lb; 20 e, 43 h.

**Powell St. Ry. Co.** (Rm. 32 Merchants' Exchange).—Pr W. J. Adams, Sec G. H. Wagoner, Engr H. L. Hines; 16 m, 3 e, 45 lb; 64 e, 420 h (cable); cable engines 500 hp.

**Presidio & Ferries Ry. Co.**—10 m; 38 e, 22 h, 4 stn nr.

**Sutro Tunnel RR. & Cable Co.**—Pr F. K. Norroy, Sec G. K. Stevens, Spt Jas. McCord, Engr W. J. Slattery; 12 m, 5 g, 45 lb; 22 e, 34 g, 180 h; cable engines 500 hp.

**Telegraph Hill RR. Co.**—Pr Gustave Sutro, Sec & Spt Chas. J. Werner; 1,560 ft.

**Van Ness & Market RR. Co.**—Pr Leland Stanford, Sec & G.M. J. L. Willcutt; 4.5 m, 35 and 40 lb T; 22 e (16 pass, 6 flat and section), 7 stn nr. Operated by Powell St. Cable Rwy.

**San Jose** (12,567). San Jose & Santa Clara RR. Co. (20 W. Santa Clara St.)—Pr Samuel A. Bishop, Sec Eugene Rosewater, Spt Wm. Fitts; 3 m, 4-8 1/2 & 3 g, 30 and 45 lb T; 19 e (18 one-l, 1 two-h), 75 h.

**First St. & Berry RR.**—Sole owner Jacob Rich, Sec E. M. Rosenthal; 4 1/2 m, 3 g, 20 lb; 6 e, 30 h.

**First St. & San Pedro St. Depot RR. Co.**

**North Side RR. & Cable Co.**—Pr & G.M. Jacob Rich, Sec E. M. Rosenthal; 3 1/2 m, 3 g, 10 lb; 3 e, 10 h.

JOHN J. BRODERICK, Prest.

JOS. D. BASCOM, Sec. & Treas.

# Broderick & Bascom Rope Co.

Manufacturers



# ROPE

## Cable Ropes

FOR

### STREET RAILROADS.

# WIRE

St. Louis, Mo.

# The Horace A. Keefer Co., KANSAS CITY, MO.

## Street, Cable, Motor & Steam Railway

EQUIPMENT AND TRACK MATERIAL A SPECIALTY.

### PRICE'S IMPROVED FARE BOX.

THE BEST IN THE MARKET.

The ringing of a gong for each fare, checks the passenger as well as the driver, and hence conductor's bell punch is unnecessary. It is positively the best fare collector in the *World*.

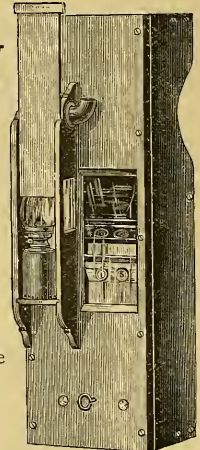
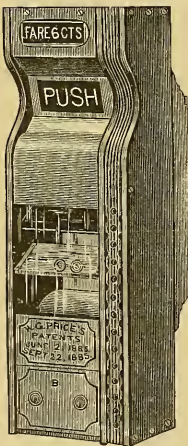

### Corliss Engines, Safety Boilers, Feed-Water Heaters, Pumps,

WINDING GEAR AND CABLE OUTFITS COMPLETE

Can always secure our customers good bargains in second-hand Supplies and Equipments.





# FRANK H. ANDREWS,

SUCCESSOR TO

ANDREWS & CLOONEY, F. T. LERNED, Gen'l Agt.

MANUFACTURER AND CONTRACTOR FOR

## CONSTRUCTING STREET RAILWAYS.

THE BUILDING OF

# CABLE ROADS

AND FURNISHING MATERIALS FOR SAME, A SPECIALTY.

*All kinds of Steel and Steel Grooved Rails, Straight or Bent to any Radius. Knees, Fishplates, Spikes, Bolts, Etc., Etc.*

## MACHINERY:

*Wheel Presses, Wheel Bowers, Axle, Lathes, Drills, Etc., either for Steam or Hand Power.*

PROMPTNESS AND REASONABLE PRICES.

SEND FOR ILLUSTRATED CATALOGUE.

BRANCH OFFICES:

**BOSTON,**  
37 Central Street.

**ST. LOUIS,**  
Southern Hotel.

**CHICAGO,**  
Lakeside Building.

Represented in California by WM. B. ISAACS, 258 Market Street, San Francisco.



Sioux City (7,366). St. Louis City St. Ry. Co.—Pr & Spt Fred T. Evans, Jr., Sec James P. Peaney; 10 m, 4 g, 45 lb; 20 m, 100 lb, 30 m.

Waterloo (5,330). Pr. Ry. H. Hartman, Sec T. N. Kellough, Spt J. A. Foye; 2 m, 3 g, 20 lb T; 3 c, 10 h.

KANSAS.

Athlete (2,300). The Ab. St. Ry. Co.—Pr & Spt M. M. Shipley, Sec G. H. Hawk; 2.25 m, 20 lb T; 4 g, 5 c, 15 h.

Ashland (—). Ashland St. Ry. Co.—Pr J. H. Besson, Sec J. C. Tomlinson, Spt A. H. Denny; 1.5 m, 18 lb 45 lb; 17 c, 13 h, 43 m.

Atchison (15,105). Atchison St. Ry. Co.—Pr J. H. Besson, Sec J. C. Tomlinson, Spt A. H. Denny; 1.5 m, 18 lb 45 lb; 17 c, 13 h, 43 m.

Clay Center (1,753). Cl. C. City Ry. Co.—Pr A. M. Stratton, Sec & Tr Wm Sharpe, Spt O. E. Wall; 1 m, 25 lb T; 3 g, 10 m.

Council Grove (1,043). Con. Gro. St. Ry. Co.—Pr W. H. White, Sec H. W. Glendon, Spt L. W. Meier; 1 m, 3-9 g, 18 lb T; 2 c, 2, 2 m.

Emporia (4,832). Emp. St. Ry. Co.—Pr J. H. Holmes, Sec & Spt J. D. Holden; 3.5 m, 3-6 g, 20 lb T; 8 c, 24 m.

Ford Scott (3,372). Doniphan County St. Ry. Co.—Pr H. W. Pearsall, Sec C. W. Goodenough, Spt W. R. Gross; 1 m, 4 g, 16 lb T; 14 c, 4 h, 24 m, 1 stn m.

Garden City (250). Garden City St. Ry. Co.—Pr H. W. Pearsall, Sec C. W. Goodenough, Spt W. R. Gross; 1 m, 4 g, 16 lb T; 14 c, 4 h, 24 m, 1 stn m.

Hutchinson (1,638). The Hut. St. Ry. Co.—Pr A. L. Forsha, Sec P. A. Forsha; Spt K. E. Stuart; 2.5 m, 4-6 g, 20 lb T; 5 c, 22 h.

Junction City (2,684). Junc. City St. Ry. Co.—Pr J. H. Stout, Sec S. G. Blincock, Spt E. K. Kingman (300). Kingman City St. Ry. Co.—Pr H. Stout, Sec S. G. Blincock, Spt E. K. Kingman (300).

Lawrence (8,511). Law. Tr. & P. Ry. Co.—Pr H. Tinsiao, Sec W. N. Bangs, Spt Geo. Fricker; 5.5 m, 4-1 g, 38 lb T; 8 c, 34 h, 24 m.

Lawrence (16,740). Lawrence St. Ry. Co.—Pr H. Tinsiao, Sec W. N. Bangs, Spt Geo. Fricker; 5.5 m, 4-1 g, 38 lb T; 8 c, 34 h, 24 m.

Newton (2,603). Newton St. Ry. Co.—Pr A. Moore, Sec W. O. Oldfield; 6 m, 3-6 g, 20 lbs; 8 c, 24 m.

Ottawa (4,322). Ott. St. Ry. Co.—Pr John P. Harris, Sec Peter Shiras, Spt David Miller; 2 m, 20 lb; 4 c, 10 m.

Parsons (4,196). Pars. St. Ry. Co.—Pr Angell Mathewson, Sec & Tr G. W. Hawk, Spt J. O. Hart; 1.087 m, 4-6 g, 18 lb T; 5 c, 22 h.

Salina (2,111). The Salina Ry. Co.—Pr M. D. Herrington, Sec A. L. Dodge, Spt L. W. Pershing; 2 m, 3-6 g, 20 lb T; 3 c, 10 m.

Strong City (—). Strong City St. Ry. Co.—Pr E. A. Hilderbrand, Sec W. P. Martin, Spt Joe Hume, Engr John Frew; 2 m, 3-6 g, 20 lbs T; 3 c, 4 m.

Topeka (15,451). Topeka City (Consolidated) Ry. (1.16 W, 10th St.)—Owner: The Topeka and W. Ry. Co.—Pr Geo. E. Farnham, Sec Jesse Shaw; 12.5 m, 4 g, 38 c, 65 m.

Top. Rapid Transit St. Ry. Co.—Pr John Francis; Sec J. B. Bartholomew; 12 m, 40 lb; 2 c, 4 m.

Wellington (2,694). Citizens' St. Ry. Co. of Wc.—Pr J. O. Woods, Sec & Spt D. A. Espley; 3 m, 16 lb T; 5 c, 14 m.

Wyand (2,814). Wyand St. Ry. Co.—Pr J. O. Woods, Sec & Spt D. A. Espley; 3 m, 16 lb T; 5 c, 14 m.

KENTUCKY.

Covington (2,970). South Covington & Cincinnati St. Ry. Co.—Pr E. F. Abbott, Sec J. H. B. Smith; 2.5 m, 4-6 g, 20 lb T; 5 c, 22 h.

Dayton (3,210). Newport & Dayton St. Ry. Co.—Pr & Supt W. V. Bean; 2 m, 5-2 1/2 g, 43 and 52 lb; 10 c, 40 h.

Lexington (18,400). Lex. St. Ry. Co.—Pr & Tr R. B. Metcalfe, VP, GM & Sec Albert Cross, Spt W. M. Moore; 8 m, 4.10 g, 20 lb T; 20 c, 82 h.

Louisville (123,755). Central Pass. R.R. Co.—Pr B. du Pont, Sec T. C. Donigan; 53 m, 6 g, 52 lb; 10 c, 40 h.

Crescent Hill Ry. Co.—3 m. Leased to and operated by the Central Pass. R.R. Co. Kentucky St. Ry. Co.—Pr T. J. Minary, Sec C. C. Donigan; 9 m, 52 lb; 8 c.

Louisville City Ry. Co.—Pr Major Alex. H. Davis (Cyracuse, N. Y.) Spt H. H. Littell; 75 m, 5 g; 42.54 & 53 1/2 lb; 242 c, 1500 m.

Mayfield (5,220). May. St. Ry. Co.—Pr L. W. Robertson, Sec & Tr W. S. Frank; 3 m, 20 lb; 6 c, 32 m.

Paducah (8,036). Pad. St. Ry. Co.—Pr L. W. Robertson, Sec & Tr W. S. Frank; 3 m, 20 lb; 6 c, 32 m.

LOUISIANA.

New Orleans (216,090). Canal & Chalmette RR. Co. (6 Camp St.)—Pr E. J. Hart, Sec & Spt J. S. DeGrange; 13 m, 5-2 g, 37 lb; 40 c, 210 m.

Algiers & Gretna Ry. Co. (Box, 457)—Pr J. E. Aubray, Sec Wm. Bagel, Spt John Kennedy; 1.5 m, 3-6 g, 20 lb T; 5 c, 22 h.

Crescent City R.R. Co. (P. O. Box 18491)—Pr J. W. Irbahn, Sec Jno. R. Juden, Spt A. V. Smith; 26 m, 5-2 1/2 g, 35 & 45 lb; 88 c, 66 h, 330 m.

New Orleans City Ry. Co.—Pr J. M. Moore, Sec J. M. Hernandez, Sec W. F. Crouch, Spt C. W. Hale; 17 m, 30 lb; 60 c, 25 lbs, 175 lb, 16 stn m.

New Orleans City & Lake R.R. Co. (102 Canal St.)—Pr J. A. Walker, Sec W. E. Leverich, Spt E. Wintz; 60 m, 5-2 1/2 g, 48 lb; 170 c, 40 coaches, 7 stn m (800 lb).

Orleans R.R. Co.—Pr & Spt H. Larque, Sec & Tr P. Congot; 9.5 m, 5-2 1/2 g, 35 lb; 52 c, 43 h, 10 m.

St. Charles St. R.R. Co. (Cor. 8th and Carondelet Sts.)—Pr & Spt Alden McLeellan, Sec Vincent Riviere; 11.375 m, 5-2 1/2 g, 40 lb; 61 c, 260 m.

Shreveport (8,009). Shriv. City R.R. Co.—Pr J. L. Yource; 1.5 m, 4-4 g, 46 lb; 6 c, 15 h.

MAINE.

Lewiston (19,083). Lew. & Auburn Horse R.R. Co.—Pr Frank W. Dana, Sec C. C. Corbett, Spt J. E. Fairbanks; 7.97 m, 30, 35 & 50 lb; 22 c, 40 h.

Portland (38,810). Port. R.R. Co.—Pr H. J. Luby, GM & Sec E. A. Newman; 10 m, 35 & 45 lb; 39 c, 174 h.

Ocean St. Horse R.R. Co.—1.5 m; operated by Port. R.R. Co.

MARYLAND.

Baltimore (332,313). Balt., Brooklyn & Cedar Hill Ry. Co.—Pr C. Orrick Swann, Sec & Attorney C. C. Long, Spt T. M. Thompson; 10 m, 5-2 g, 30 lb; 30 c, 40 h.

Balt. Catonsville and Ellicott's Mills Pass. Ry. Co.—Pr T. C. Robbins, Sec Wm. W. Oudring; 8 m, 5-4 1/2 g, 35 lb T; 11 c, 40 h.

Balt. City Pass. Ry. Co. (17 E. Baltimore Sts.)—Pr & Spt Ogden Bowie, Sec S. R. Bridge; 44.5 m, 5-4 1/2 g, 46 & 47 lb; 125 c, 1164 h.

Balt. Fidelity & Potomac R.R. Co.—Pr F. H. Walker, Sec F. Caughey; 6 m, 5-4 g, 30 lb; 4 c, 18 h.

Balt. & Potomac Ry. Co. (406 Laurens St.)—Pr & Tr E. D. Freeman, Sec R. B. Clark, Spt M. Ketter; 6 m, 5-4 g, 30 lb T; 5 c, 18 h.

Balt. Union Pk. Ry. Co.—Pr F. M. C. R. R. Co.—Pr & Spt Leo Feuder; 16 m, 5-4 1/2 g, 47 lb; 56 c, 405 h.

Balt. & Yorkville Ry. Co. (16 N. Holliday St.)—Pr Samuel H. Tagart, Spt A. D. Sawks; 11.5 m, 5-4 1/2 g, 45 and 45 lb; 19 c, 135 h.

Central Ry. Co. (508 and 505 E. Preston St.)—Pr & Spt Peter Thompson, Sec Walter Bland; 10 m, 5-4 g, 40 lb; 22 c, 180 h.

Citizens' Ry. Co.—Pr J. S. Hagarly, Sec W. Hammersly, Spt C. C. Speed; 24 m, 5-4 1/2 g, 45 lb; 60 c, 450 h.

Hightstown, P. C. Ry. Co.—Pr Francis Hazlehurst, Sec Jas. Smith; 10 m, 5-4 1/2 g, 35 lb; 30 c, 100 h.

North Balt. Pass. Ry. Co.—Pr & G. M. Jas. L. McLane, Sec Thos. J. Wilson; 20 m, 5-4 1/2 g, 43 lb; 30 c, 180 h.

The People's Ry. Co.—Pr T. E. Edw. Hambleton, Sec & Spt Wm. A. House, Jr; 13 m, 5-4 1/2 g; 38 c, 205 h.

MASSACHUSETTS.

Boston (362,839). Boston & Chicago R.R. Co. (27 Tremont Row.)—Pr W. W. Wheldon, Sec J. H. Studley, Jr; 4.154 m, 56 lb; operated by the Lynn & Boston R.R. Co; leased by the Boston Consolidated St. Ry. Co.

Boston Concord & Lynn R.R. Co. (27 Tremont Row.)—Pr Chas. E. Powers, Tr Moody Merritt, Spt Julius E. Kung, Spt John H. Studley; 40.951 m, 56 lb; 349 c, 1747 h.

East Middlesex St. Ry. Co. (35 Congress St.)—Pr Amos F. Breed, Spt Gilman F. Jones; 15 m, 35 lb; 57 c, 30 h; only a portion being in operation.

North Woburn St. R.R. Co. (35 Congress St.)—Officials same as East Middlesex; 4.82 m; 13 c, 38 h.

Lynn & Boston R.R. Co. (13 Tremont Row.)—Pr Amos F. Breed, Spt Elwin C. Foster, Clerk E. Francis Oliver; 42.182 m, 35 and 48 lb; 175 c, 747 h, 1 m.

Metropolitan R.R. Co. (175 Broadway, N. Y.)—Pr Calvin A. Richards, Sec Wm. F. Harvey; 37.119 m, 30 to 54 lb; 721 c, 3661 h.

South Boston R.R. Co. (715 Broadway, So. Boston.)—Pr Chas. H. Hersey, Spt Daniel Coediger; 13.220 m; 25 c, 950 h.

Somerville Horse R.R. Co. (27 Tremont Row.)—Pr Samuel E. Sewall, Sec John H. Studley, Jr; 4.879 m, 56 lb; operated by the Cambridge and Consolidated Companies.

Whitinsmet Hill Co. (13 Tremont Row.)—Pr Wm. R. Pearmain, Clerk E. Francis Oliver; 1.966 m, 45 lb; road leased to Lynn & Boston R.R. Co.

Shirburn St. Ry. Co. (13 Tremont Row.)—Pr Henry M. Whitney, Sec M. J. Wickinson, Jr; road not yet built.

West End St. Ry. Co. (Equitable Building.)—Pr Henry M. Whitney, Sec Elmer L. Howe; road not yet built.

Brockton (13,608). Brockton St. Ry. Co.—Pr W. W. Cross, Spt H. B. Rogers; 11.5 m, 35 lb; 32 c, 125 h.

Cambridge (22,602). Mt. R. Co.—Pr Ventilas Cummings, Spt Wm. A. Bancroft; 92 m, 40 and 50 lb; 327 c, 1725 h.

Fall River (11,321). Chicopee St. R.R. Co.—Pr Wm. A. Bancroft, Spt H. B. Rogers; 11.5 m, 35 lb; 32 c, 125 h.

Haverhill (18,175). Hav. & Greenland St. Ry. Co. (3 Water St.)—Pr Jackson B. Sweet, Sec John A. Colby; 13.78 m, 30 and 35 lb; 39 c, 126 h.

Holyoke (21,915). Hol. St. Ry. Co.—Pr Wm. A. Chase, Sec W. H. Brooks, Spt H. M. Smith, Engr G. Fayette Smith; 4 m, 35 lb; 15 c, 55 h, 2 m.

Lowell (19,175). Lowell Horse R.R. Co.—Pr Wm. E. Livingston, G M J. A. Russell, Sec Jas. H. Eaton, Spt A. N. Kimball; 6.7 m, 45 lb; 24 c, 95 h.

Lowell (19,175). Lowell Horse R.R. Co.—Pr Wm. E. Livingston, G M J. A. Russell, Sec Jas. H. Eaton, Spt A. N. Kimball; 6.7 m, 45 lb; 24 c, 95 h.

Lowell (19,175). Lowell Horse R.R. Co.—Pr Wm. E. Livingston, G M J. A. Russell, Sec Jas. H. Eaton, Spt A. N. Kimball; 6.7 m, 45 lb; 24 c, 95 h.

Lowell (19,175). Lowell Horse R.R. Co.—Pr Wm. E. Livingston, G M J. A. Russell, Sec Jas. H. Eaton, Spt A. N. Kimball; 6.7 m, 45 lb; 24 c, 95 h.

Lowell (19,175). Lowell Horse R.R. Co.—Pr Wm. E. Livingston, G M J. A. Russell, Sec Jas. H. Eaton, Spt A. N. Kimball; 6.7 m, 45 lb; 24 c, 95 h.

Lowell (19,175). Lowell Horse R.R. Co.—Pr Wm. E. Livingston, G M J. A. Russell, Sec Jas. H. Eaton, Spt A. N. Kimball; 6.7 m, 45 lb; 24 c, 95 h.

Lowell (19,175). Lowell Horse R.R. Co.—Pr Wm. E. Livingston, G M J. A. Russell, Sec Jas. H. Eaton, Spt A. N. Kimball; 6.7 m, 45 lb; 24 c, 95 h.

Lowell (19,175). Lowell Horse R.R. Co.—Pr Wm. E. Livingston, G M J. A. Russell, Sec Jas. H. Eaton, Spt A. N. Kimball; 6.7 m, 45 lb; 24 c, 95 h.

Lowell (19,175). Lowell Horse R.R. Co.—Pr Wm. E. Livingston, G M J. A. Russell, Sec Jas. H. Eaton, Spt A. N. Kimball; 6.7 m, 45 lb; 24 c, 95 h.

Lowell (19,175). Lowell Horse R.R. Co.—Pr Wm. E. Livingston, G M J. A. Russell, Sec Jas. H. Eaton, Spt A. N. Kimball; 6.7 m, 45 lb; 24 c, 95 h.

Lowell (19,175). Lowell Horse R.R. Co.—Pr Wm. E. Livingston, G M J. A. Russell, Sec Jas. H. Eaton, Spt A. N. Kimball; 6.7 m, 45 lb; 24 c, 95 h.

Lowell (19,175). Lowell Horse R.R. Co.—Pr Wm. E. Livingston, G M J. A. Russell, Sec Jas. H. Eaton, Spt A. N. Kimball; 6.7 m, 45 lb; 24 c, 95 h.

Lowell (19,175). Lowell Horse R.R. Co.—Pr Wm. E. Livingston, G M J. A. Russell, Sec Jas. H. Eaton, Spt A. N. Kimball; 6.7 m, 45 lb; 24 c, 95 h.

Lowell (19,175). Lowell Horse R.R. Co.—Pr Wm. E. Livingston, G M J. A. Russell, Sec Jas. H. Eaton, Spt A. N. Kimball; 6.7 m, 45 lb; 24 c, 95 h.

Lowell (19,175). Lowell Horse R.R. Co.—Pr Wm. E. Livingston, G M J. A. Russell, Sec Jas. H. Eaton, Spt A. N. Kimball; 6.7 m, 45 lb; 24 c, 95 h.

Lowell (19,175). Lowell Horse R.R. Co.—Pr Wm. E. Livingston, G M J. A. Russell, Sec Jas. H. Eaton, Spt A. N. Kimball; 6.7 m, 45 lb; 24 c, 95 h.

Lowell (19,175). Lowell Horse R.R. Co.—Pr Wm. E. Livingston, G M J. A. Russell, Sec Jas. H. Eaton, Spt A. N. Kimball; 6.7 m, 45 lb; 24 c, 95 h.

Lowell (19,175). Lowell Horse R.R. Co.—Pr Wm. E. Livingston, G M J. A. Russell, Sec Jas. H. Eaton, Spt A. N. Kimball; 6.7 m, 45 lb; 24 c, 95 h.

Lowell (19,175). Lowell Horse R.R. Co.—Pr Wm. E. Livingston, G M J. A. Russell, Sec Jas. H. Eaton, Spt A. N. Kimball; 6.7 m, 45 lb; 24 c, 95 h.

Lowell (19,175). Lowell Horse R.R. Co.—Pr Wm. E. Livingston, G M J. A. Russell, Sec Jas. H. Eaton, Spt A. N. Kimball; 6.7 m, 45 lb; 24 c, 95 h.

Lowell (19,175). Lowell Horse R.R. Co.—Pr Wm. E. Livingston, G M J. A. Russell, Sec Jas. H. Eaton, Spt A. N. Kimball; 6.7 m, 45 lb; 24 c, 95 h.

Lowell (19,175). Lowell Horse R.R. Co.—Pr Wm. E. Livingston, G M J. A. Russell, Sec Jas. H. Eaton, Spt A. N. Kimball; 6.7 m, 45 lb; 24 c, 95 h.

Lowell (19,175). Lowell Horse R.R. Co.—Pr Wm. E. Livingston, G M J. A. Russell, Sec Jas. H. Eaton, Spt A. N. Kimball; 6.7 m, 45 lb; 24 c, 95 h.

MICHIGAN.

Ann Arbor (8,061). Ann Arbor St. Ry. Co.—Pr J. E. Beal, Sec Z. P. King, Spt T. J. Keech.

Battle Creek (7,063). Batt. Creek St. Ry. Co.—Pr G. L. Beveridge (Chicago), Sec H. C. Spaulding; 1.5 m, 3-6 g, 20 lb T; 5 c, 22 h.

Bay City (20,693). Bay City St. Ry. Co.—Pr Jas. Clements, Sec Edgar A. Hooley; 7.25 m, 4-8 1/2 g, 18 lb; 32 c, 46 h.

Detroit (118,362). Detroit St. Ry. Co.—Pr Sidney D. Miller, Sec & Tr Geo. Hendrie; 33 m, 4-7 1/2 g, 43 lb; 118 c, 100 h.

Detroit Electric Ry. Co.—Pr H. M. Campbell, Sec Bethune DuMelft; 2 m, 20 lb T; 2 electric m; 2 c and 2 pad c.

Fort Wayne & Elmwood Ry. Co.—Pr Henry B. Brown, Sec N. W. Goodwin, Spt G. S. Hazard; 11.25 m, 45 lb, 41 c, 245 h.

Grand Haven & Spring Lake Ry. Co.—Pr J. W. Dalley, Sec J. W. Dalley, Spt C. M. Dalley; 5.25 m, 45 lb; 15 c, 55 h.

Highland Park Ry. Co. (82 Griswold St.)—Pr Frank E. Snow, Sec Fremont Wood; 1.5 m, 3-6 g, 20 lb T; 5 c, 22 h.

Metropolitan Electric Ry. Co. (82 Griswold St.)—Pr W. A. Jackson, Sec Tr Frank E. Snow. To be built on Fisher's electric system.

East Detroit (19,011). East Detroit St. Ry. Co.—Pr Walter A. Jones, Acting Sec Chas. A. Bartlett, Spt A. Bartlett; 8 m, 30 and 45 lb; 26 c, 80 h, 4 m.

Grand Rapids (32,015). St. Ry. Co. of Gr. Rap.—Pr W. J. Hayes, Sec I. M. Weston, Spt A. L. Bevier; 14.5 m, 35 lb; 34 c, 230 lb, 2 stn m.

Jackson (16,105). Jackson St. Ry. Co.—Pr H. H. Smith, Sec S. Hopewell; 11 c, 42 h.

Kalamazoo (13,552). Kal. St. Ry. Co.—Pr H. E. Irish, Sec & Spt Arthur Ellthorp Enz; Wm. Shakespear; 8.18 m, 4-8 g, 30 lb; 30 c, 50 h.

Lansing (5,319). Lan. City Ry. Co.—Pr Stephen G. Clark (Chicago), Sec Judge John P. Alstead (Chicago), Spt H. M. Clark; 9 m, 30 lb; 7 c, 24 h.

Muskegon (11,822). Muskegon Ry. Co.—Pr Fred A. Nims, Sec H. B. Rogers, Spt Wm. McLaughlin; 3-5 m, 3-6 g, 16 lb T; 10 c, 20 h, 9 m.

Port Huron (8,875). Port Huron Electric Ry. Co.—Pr Wm. F. Botsford, Sec Spt Jas. H. Talbot; 8.875 m, 27 lb; 6 c, 11 h, 3 electric m; (Van Depoef's). One 15 hp, and two 10 hp, each, engine, 55 hp. Connects with Gratiot Electric Ry.

Saginaw (10,526). City of Sag. R.R. Co.—Pr Du. H. Jerome, Sec Geo. F. Williams, Spt Fred G. Benjamin; 3-5 m, 4-8 g, 42 lb; 15 c, 48 h.

St. Joseph (2,603). St. Joseph & Benton Harbor St. Ry. Co.—Pr & Spt M. C. Burnes, Sec Warren Ballinger; 1.75 m, 30 lb; 5 c, 24 m.

MINNESOTA.

Duluth (3,483). Duluth St. Ry. Co. (1102 Redmont Ave.)—Pr Saml. Hill, Sec S. C. Chase, Spt T. W. Hoopes; 5 m, 3-8 g, 33 and 48 lb; 13 c, 4 h, 98 m.

Mankato (5,550). The Man. St. Ry. Co.—Pr & Spt Willard M. Farr, Sec John C. Johnson; 1.5 m, 3-6 g, 20 lb T; 5 c, 22 h.

Minneapolis (46,877). Minneapolis St. Ry. Co.—Pr Thos. Lowry, Sec C. G. Goodrich, Spt Wm. Sharp; 61 m, 3-6 g; 186 c, 773 h, 226 m.

Min. West Side St. Ry. Co.—Pr Wm. West Side St. Ry. Co.—Pr C. C. McClure, Sec F. T. McLaughlin; 3 m, 4-2 g, 27 lb T; 5 c, 22 h.

St. Paul (41,417). St. Paul City Ry. Co.—Pr Thos. Lowry, Sec A. Z. Levering, Spt A. L. Scott; Engr E. F. Abbott; 50 m, 52 lb; 128 c, 416 h, 201 m.

St. Paul & Duluth Ry. Co.—Pr Wm. West Side St. Ry. Co.—Pr C. C. McClure, Sec F. T. McLaughlin; 3 m, 4-2 g, 27 lb T; 5 c, 22 h.

Stillwater (9,055). Union Depot St. Ry. & Transfer Co.—Receiver G. M. Brush; 5 m, 30 lb.

Win. City Ry. Co.—Pr B. H. Langley, Sec & Tr C. H. Porter; Spt L. W. Wilson; 4 m, 3-6 g, 27 lb T; 10 c, 39 h.

MISSISSIPPI.

Enterprise (1,035). Ent. St. Ry. Co.—Pr John Kamp, Sec John W. Gaston, Engr Sam Lewis; 1.35 m, 3-6 g, 20 lb T; 5 c, 22 h.

Jackson (3,034). Jac. St. Ry. Co.—Pr F. W. People, Sec & Tr J. B. Bradford; 1.5 m, 5 g, 3 c, 12 m.

Meridian (4,008). Mer. St. Ry. Co.—Pr Geo. S. Covert, Sec R. M. Houston, G M J. A. Russell, Sec Wm. A. Bancroft; 2.5 m, 4-8 g, 16 lb T; 5 c, 1 frt c, 20 m.

# CAR HEATING

WITH CLINE'S PATENT HEATER AND

## Aromatic Carbonic Compound Composition Fuel



CHEAP. CONVENIENT. SAFE.

Once Filling lasts 18 hours.

NO CUTTING OF CAR TO PUT IN.

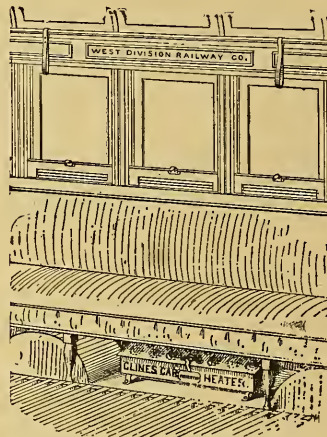
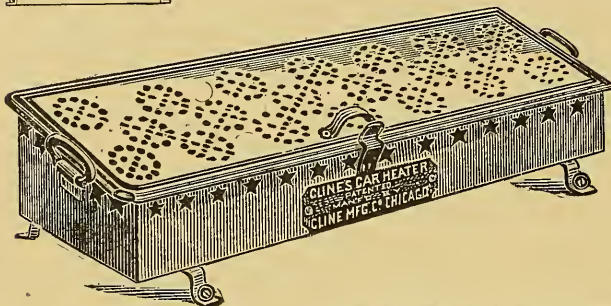

**ADOPTED BY THE FOLLOWING ROADS:**

Office of THE CHICAGO FIRE UNDERWRITERS' ASSO.,  
157 to 163 LaSalle Street, Rooms 31 & 33.  
T. A. BOWDEN, Sup't of Surveys,  
D. C. Cregier, Sup't West Div. Railway Co.

Chicago, Ill., Oct. 28, 1886.  
Dear Sir:—I have examined into the Cline Manufacturing Co.'s Heater, also Cline's Aromatic, Carbonic, Composition Fuel, and I see no reason why you should not put them in the cars, provided they are securely fastened down to the floor; and when fire is applied to them it should be carried around in a metal can, and a small shovelful dropped into the stationary heater when in the car. Also in no case should there be hay in the car when the heater is fired up. Yours truly,  
T. A. BOWDEN, Sup't of Surveys.

CHICAGO WEST DIVISION RAILWAY COMPANY,  
Office of the Sup't, DEWITT C. CREGIER.  
To whom it may concern.

Chicago, Jan. 21, 1887.  
This is to certify that this company has in use over 200 Cline's Heaters in their cars. Respectfully,  
DEWITT C. CREGIER, Supt.

SOUTH CHICAGO CITY RAILWAY CO.,  
Room 46 Calumet Bld'g, 191 LaSalle St.  
Messrs. L. Cline & Bro., Chicago.

Chicago, Feb. 8, 1887.  
Gentlemen:—We have used your Heaters in our cars since the first of December last, and have found them entirely satisfactory. During the coldest weather the temperature in the cars has been maintained at about 45 degrees. We cheerfully recommend the Cline Heater to other street railroads.  
D. S. TAYLOR, Pres't.

W. H. HARTMAN, Pres't. T. N. KELLOGG, Sec'y & Treas  
J. A. FOVE, Vice Pres't & Sup't.  
Office of WATERLOO STREET RAILWAY CO.,  
Cline Mfg. Co., Chicago.

Waterloo, Iowa, Feb. 5, 1887.  
Gents:—We are just testing your Heaters. We are well pleased with the results thus far. There is no question but that two of them will heat a 12 foot street car when the mercury is "way down" below zero. I think you have at last solved a "long felt want." Very respectfully yours,  
Waterloo Street Railway Co., by W. HARTMAN.

W. S. ROBINSON, Pres't.  
D. C. KELLOGG, Vice Pres't.

Office of CITY OMNIBUS COMPANY,  
68 South Canal Street,

Chicago, Feb. 5, 1887.  
Gentlemen:—We are using the Cline Manufacturing Company's Heater and Fuel this winter in our Omnibuses, and find it makes one-half difference in the increase of the travel. I would recommend it to any Omnibus or Car Company, as they will never do without it if they use it once. We could not get along without it and cheerfully recommend it to the public.  
Respectfully,  
S. J. RUSSELL, Sup't.

R. PATRICK & CO., BANKERS.  
Cline Mfg. Co., Chicago.

Pittsburg, Feb. 12, 1887.  
Dear Sir:—We have in use on the Pittsburg and Birmingham Passenger R. R. cars, the Cline & Bro. Patent Heater and Fuel. Having used the same for the past two months they have given us entire satisfaction and contributed to the comfort and pleasure of our patrons.  
Respectfully,  
W. W. PATRICK, Pres't.

President's Office, RICHMOND CITY RAILROAD,  
J. C. SHAFFER, Pres't.  
Cline Mfg. Co., Chicago, Ill.

Richmond, Ind., Feb. 28, 1887.  
Gents:—Your favor of Feb. 28 received and noted. We used your heater such a short time that we hardly feel competent to speak about its value. It gave satisfaction during the time it was in use. Next winter we will give it a more thorough test. Yours truly,  
J. C. SHAFFER.

CHICAGO WEST DIVISION RAILWAY COMPANY,  
Office of the Superintendent.  
DEWITT C. CREGIER, Supt.  
To whom it may concern:

Chicago, July 21, 1887.  
The Cline Car Heater was placed on a number of the cars of this company during last winter, giving good results so far as known.  
DEWITT C. CREGIER, Sup't.

# Cline Manufacturing Company,

277 & 279 S. CANAL ST., CHICAGO, ILL.













MEXICO.

Chihuahua (12,000). Chihuahua St. R.R. Co.—GM A. Gonzalez, Jr.
Corazon (4,896). Ferro-Carril Urbano de Cordova—GM Jose Antonio Cabral; 2 m, 3-10 g; 5 c, 46 m.
Jalapa (10,000). Jalapa Tramway (Branch of the Mexican Ry.)—Pr T. C. Sanders, Sec J. T. Denniston, Spt John Traillkill; 61.25 m; operated by mules and horses.
Matamoros (20,000). Ferro-Carril Urbano de Matamoros y Santa Cruz.—Owner Francisco Armentia; 7 m, 4-11 g, 36 lb; 13 c (8 pass.), horses and mules.
Merida (45,000). Merida St. Ry.—Proprietor Rudolf G. Canton.
Mexico (300,000). District St. Ry. Co. of the City of Mexico.—Compania Limitada de Ferrocarriles del Distrito (Callejon de Bettemitas No. 12).—Pr Angel Lerdo de Tejada, Administrador General F. P. de Castillo; 91 m, 30, 40 and 70 lb; 226 c, 48 h, 1560 m.
Circuito de Banos St. Ry.
Monterey (25,000). Monterey and Santa Catalina Ry. Co.—Pr W. L. Heermann (313 Broadway St., New York), VP & GM A. C. Schryver, Sec Frank Knudt, Spt Sam H. Fisk; 10.6 m, 3-0 g, 25 lb; T; 1 c (15 pass., 3 frt), 60 m.
Nuevo Laredo (2,000).
Tehuacan (22,000). Ferro-Carril Nacional de Tehuacan a Esperanza (Tehuacan and Esperanza Tramway)—Pr Ramon Fernandez, GM Fernando de Maria y Campos, Spt Telex Eizarrro; 31 m, 30 lb, 62 c (Stephenson's) 200 m.
Vera Cruz (16,000). Vera Cruz St. Ry. Co.—Pr F. Moscar.

CENTRAL AMERICA AND WEST INDIES.

CUBA.

Havana (25,000). Havana City Ry.—13 m, 52 c, 5 stu m.
Regla and Guanabacoa Tramway—3 m; 10 c, 5 stu m.
Matanzas (—). Matanzas Ry.—1.65 m.
San Miguel de Baga Ry.—5.5 m, 45 lb.

HAYTI.

Port au Prince (25,000). Port au Prince St. Ry. Co.—Pr & Tr C. Lundmann (55 and 57 Beaver st., New York), Spt R. T. Crain; 4 m, 3-6 g, 20 c (10 pass.).

PUERTO RICO.

Aquadilla (—). Tramway of the Estate "Casualidad."—GM Carlos Alers; 1.25 m, 1-11 1/2 g, 20 c.
Tramway of the Estate "Coloso."—GM Emilio Vadi; 1.25 m, 1-7/8 g, 30 c.
Tramway of the Estate "Millagro."—GM & Owners Amell Julia & Co.; 2.5 m, 1-7/8 g, 40 c.

SAN DOMINGO.

Puerto Plata (—). Muelle Nuevo Tramway.—Owners Jose Sinebra and associates, GM Thos. Simpson, Spt Ed. Eugaria; 1.25 m, 4 g, 16 lb; 22 c (stationary).

SAN SALVADOR.

San Salvador (18,500). San Salvador and Santa Tecla Tramway (built by Government).—Owner F. Canacho, of Guatemala.

SOUTH AMERICA.

ARGENTINE REPUBLIC.

Buenos Ayres (295,000). Anglo-Argentine Tramways Co. (4 Copthall Buildings, London, and at Buenos Ayres).—Local Dir J. B. Waokly, Sec Louis Striem; 27 m, 42 lbs; 119 c, 659 h.
Boca & Furca Tramway of Buenos Ayres.—3.33 m, 40 lbs; 10 c, 300 h.
Buenos Ayres & Belgrano Tramways Co., Limited.—Man Dir J. E. Wanklyn, Sec Jas. Anderson (61 Moorgate st., London); 14 m, 40 lbs; 56 c, 420 h.
Central Tramway of Buenos Ayres.—15.3 m, 40 lbs; 32 c, 336 h.
City of Buenos Ayres Tramways Co., Limited.—GM H. W. Ford, Sec John Heaton (1 G. Winchester st., London); 32.87 m, 40 lbs; 187 c, 1,500 h.
Concordia (—). Tramway del Comercio.—Owner & GM Federico Zorraquin; 3.5 m, 3-10 g, 35 lb; 8 c, 50 h.

BRAZIL.

Bahia (128,929). Companhia de Ferro-Carril Transportes Urbanos.—Spt Theodore de Gomes; 20.5 m, 40 lb; 89 c, horses and 5 stu m; stationary engine for inclined plane, and a hoisting machine 191 feet lift.
Vieiros Economicos.—GM Sr Joaquin Per Carvalho; 5 m.
Niterohy (—). Niterohy Tramway.
Pernambuco (116,671). Ferro-Carril de Pernambuco (Rua 1 de Marco 77, Rio de Janeiro).—Pr Honorio Augusto Ribeiro, Sec Custao Foubiero da Fonseca, Spt Gustavo Adolpho Smit; 18 m, 40 1/2 lb; 48 c.
Recife (116,671). Brazilian St. Ry. Co., Limited.—GM H. W. S. Bird (Recife), Sec J. Eust (65 Moorgate st., London); 14.5 m, 4 g, 45 lb; 43 c, 21 trucks, 11 stu m. (Tramways in the city of Recife and suburbs.)
Recife and Olinda R.R. (Suburban tramway.)
Rio de Janeiro (374,972). Companhia Ferro-Carril do Jardim Botânico.—Pr Joas Ribeiro de Almeida, Spt S. Miller; 22 m, 43 lb; 90 c, 976 h and m.
Empresa do Plano Inclinado de Sta. Theresa.—Pr & Engr. Januario d'Alveira; inclined plane 1090 ft, tramway 2 m, 3 g, 30 and 40 lb; 1 stationary engine, 70 m.
Companhia Ferro-Carril de Sao Christavao.—Pr Francisco Pereira Passos; 51 lb, 122 c, 1,538 mu, 1 stu m.
Santos (9,871). Empresa Carris de Ferro da Villa de S. Vicente.—Owners & Man. Emmerich & Ablos; 6.5 m, 4 5/8 g, 18 and 56 lb; 18 c, 120 mu.
Sao Paulo (35,000). Sao Paulo Brazilian Ry. Co., Limited.—Sec G. A. Hillier, 111 Gresham House, Old Broad st., London; 5 m, 5-3 g, 65 lbs (part of steam railroad), with grade of 1 in 3.75 operated by cable with 1 stationary engine.

CHILE.

Santiago (200,000). Ferro-Carril Urbano di Santiago.—Pr Eduardo Malti, GM Ramiro Sanchez; 20 m (3 m in city of Santiago); 48 lb.
Valparaiso (97,737). Ferro-Carril Urbano de Valparaiso.—Sec Guillermo Lawrence, Spt & Engr Eugenio Hammer Carrera; 6 m, 5-6 g, 45 lbs; 55 c.

EUADOR.

Guayaquil (26,000). Guayaquil Tramway.—4 m.

PARAGUAY.

Anuncion (16,000). Tramway de la Ciudad de la Asuncion.—Owners Wm. Woodgate & Co. (Buenos Ayres), GM Jas. N. Horrocks; 1 m, 40 lb; 6 c.

UNITED STATES OF COLOMBIA.

Bogota (100,000). The Bogota City Ry. Co. (Bm 20, No. 1 Broadway, New York)—Pr Geo. H. Stayner (333 Clinton Ave., Brooklyn, N. Y.), VP & Sec F. W. Allen (1 Broadway, New York), Spt James E. Davies (Bogota, U. S. Colombia); 8 m, 3-3 g; 16 c, 160 m.

URUGUAY.

Montevideo (115,500). Ferro-Carril del Norte (Montevideo to the Barra de Santa Lucia); 11 m.
Tramvia Central (Central Tramway); 11 m.
Tramvia Cerrito; 2.5 m.
Tramvia del Este; 4.5 m; 86 c.
Tramvia Oriental; 5 m.
Tramvia de Paysandé.
Tramvia Paso del Molino y Cerro (Montevideo to Cerro); 13.23 m; 30 c.
Tramvia a los Pochos Europe y Union; 7 m, 30 c.
Ferro-Carril de la Union; 8.33 m; 34 c.
All these Uruguayan tramways are operated by animal traction.

VENEZUELA.

Caracas (55,638). Caracas Tramway; 3 m.
La Guaira (6,783). La Guaira and Magneta Tramway; 1.5 m, 5 g, 30 lb; 2 c.

GREAT BRITAIN AND IRELAND.

ENGLAND AND WALES.
Accrington (31,435). Accrington Tramways; 4 m, 4 g; 6 c, 6 stu m.
Aldford (2,881). Aldford & Sutton Tramway Co.—7.05 m, 2-6 g; 4 c, 14 trucks, 3 stu m.
Barrow-in-Furness (47,111). Barrow-in-Furness Tramways Co., Limited (33 Waterloo St., Birmingham).—Sec John Fellows, Engrs E. Fritchard and R. Vawser; 8.1 m, 3-6 g; 8 c, 7 stu m.

H. K. PORTER & CO., Pittsburgh, Pa.

—BUILDERS OF—

Light Locomotives

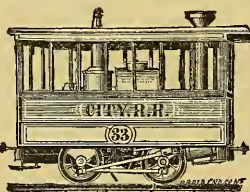

NOISELESS

Street Motors

—FOR—

EVERY VARIETY OF SERVICE.

6 x 10, 7 x 12, 8 x 12, 9 x 14, 9 1/2 x 14, 10 x 16, and 12 x 18 Cylinders for Narrow or Wide Gauge.

FINISHED PARTS KEPT ON HAND READY FOR EARLY DELIVERY.

CATALOGUE AND PHOTOGRAPHS FURNISHED ON APPLICATION.

The Hefinghoff & Laue Foundry Co.

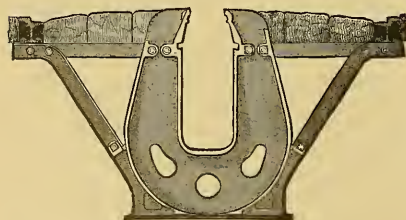

General Foundry Work, Heavy Castings and Cable Railway Work, A SPECIALTY.

Front, Lawrence and Pike Streets. Office, 154 E. Front Street, CINCINNATI.







CHEAPEST HOUSE IN THE WORLD

FOR ALL KINDS OF

# Engineers' Instruments

— FOR THE —

Survey of Cable and other Street Railways.

Transits, Levels, Rods, Chains, Tapes, Plumb-bobs, Etc., a Specialty.

## Aloe's New Model Transit,

*Especially adapted for Street Railway Work.*

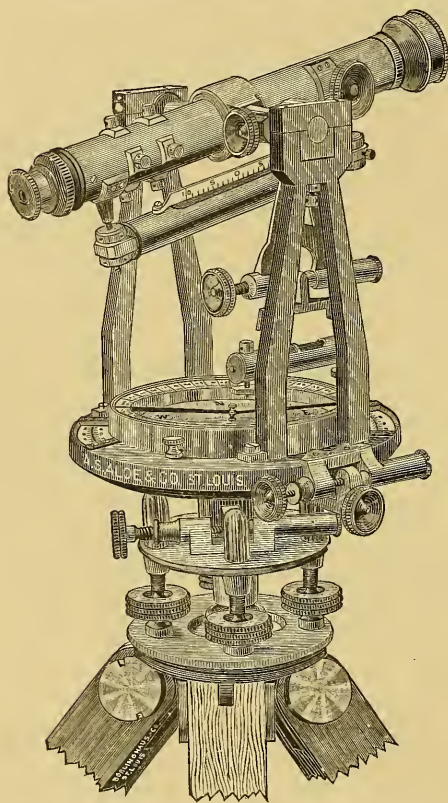

We will guarantee this instrument first-class in every respect. Send for illustrated catalogue and price list. We will make special prices to roads dealing direct.

Also, Blue Print Paper. Mathematical and Drawing Instruments, Drawing Paper, Boards, Pins, Etc. Paints, Brushes, Palettes, Etc. Curves, Pencils, India Ink, Rules, Ellipses, Engineers' Alphabets, Protractors, Compasses, Sextants, and everything for use either in the field or draughting room.

**A. S. ALOE & CO.,**

300 North 4th Street, - - ST. LOUIS, MO.



**BELLE CITY**  
**Feed & Ensilage**  
**CUTTER.**

Made in all sizes for both power and hand use. Send for Illustrated Catalogue and Price Lists. Silo and Ensilage Tronlin FREE to all who mention this Paper.  
Belle City Mfg. Co., Racine, Wis.



### Books, Periodicals, Pamphlets, Etc.

*Forty years on the Rail* is the title, and subject of an entertaining book written by Charles B. George, 130 Dundee St., Elgin, Ill., and printed and published by R. K. Donnelly & Sons, Monroe St., Chicago. (Price \$1.00.) Two-thousand copies of this book were ordered before it was printed. It is dedicated "To the conductors of the United States and other friends in the railroad service." And "in preparing those pages for publication, the author has not attempted to give a complete or consecutive history of his life as conductor on the railroad during the past forty years, for that would be beyond the scope of a simple work of this kind. On a thread of autobiography he has arranged a series of sketches, drawn from his own experiences and from those of his associates in the service, dealing with all subjects from the stand-point of a railroad man." The book is very interesting reading, and those who are struggling to "get on" may find much comfort and encouragement in it.

*Travelers' Official Guide* shows the shortest, quickest and best ways to get to the Philadelphia Convention from any part of the United States or Canada. The October number (price 50 cents) is before us. It is a wonder how such a vast amount of information can be contained in a little less than 700 pages large size paper. Not only does it show the way from one part to another, but it shows at a glance what is the time in different cities. For instance, when it is twelve o'clock (noon) by eastern time, it is only eleven o'clock by central time, and but nine in the morning by Pacific time. This guide has numerous maps; and it is adequately indexed. The *Travelers' Official Guide* is considered the recognized organ of the National General Ticket Agents' Association. The present is Vol. V, of 20th year of publication. (W. F. Allen, Manager, 46 Bond street, New York.)

*Clonic rhythmical spasm of the pronator radii teres* is the subject of the latest production of the pen of Dr. Harold N. Moyer, physician of Cook county, Ill. Street railway men are not subject to spasms of the "pronator radii teres;" but if any one should happen to be suffering therefrom, this pamphlet (which may be had for the asking) had better be read.

*The Bristol Mercury*, England, of September 16th, has been sent to the *STREET RAILWAY GAZETTE* with a prominent mark around an article on "An American Centenary," and the opening statement is a remarkable one—considering it is in a paper published so close to the British throne. "The echoes of the jubilee of Queen Victoria's reign have scarcely died away when another and a grander celebration claims the attention of the civilized world," it says. And our British contemporary goes on to pay splendid homage to "Cousin Jonathan," and compliments him on the celebration of the centenary of his Constitution, at Philadelphia last month. It was on the 17th of September, 1787, that the American Constitution was signed in the Quaker City. It was appropriate for the centennial celebration to be held there. And when, in a few days, the members and friends of the American Street Railway Association will meet in the chief city of the Keystone State (and second in the United States), they may well feel that Philadelphia is not a mean city, and that it is a place where the most important decisions have been arrived at, to which this great country of ours owes its prosperity.

CHICAGO has 8,625 street car horses.



IRELAND.

Belfast (121,602). Belfast Street Tramways Co. (7 Poultry, London, E. C. and Rando Hill, Belfast).—Chr Geo. Richardson, Sec. J. Barber Glen, GM Andrew Nance; 15 m, 61 r, 480 h.
Southampton (121,602). Southampton Ry. Co.—Chr Geo. Richardson, Sec. J. Barber Glen, GM Andrew Nance; 15 m, 61 r, 480 h.

ISLE OF MAN.

Douglas (12,511). The Isle of Man Tramways, Limited (Athol Hall, Athol Rd, Douglas).—GM John Davis, Sec. W. E. Young, Engr. W. T. Gunnon, C. E.; 2 m, 20 h.
The Quernsey Steam Tramway Co. Linn 57 Moorgate St, G.C. London.—Chr Rev. H. P. M. Hodgdon, Sec & Engr W. Gimbley; 4 m, 9 c, 6 1/2 m tr.

EUROPEAN CONTINENT.

GERMANY.

Aix-la-Chapelle (110,000). Aix-la-Chapelle & Hirschfeld Horse Ry. Co.—Dir F. Hasseiman; 13.14 in; 45 c, 138 h.
Augsburg (61,408). Augsburg Tramway.—Dir H. von Antfass; 10.207 m; 45 c, 85 h.
Barmen-Elberfeld (201,000). Kgl. Hofl. Pferde Eisenbahn Ry. Co. (office Brussels).—Dir Mende, Royal Major; 34.83 m; 73 c, 161 h.
Berlin (1,123,300). Berlin (Charlottenburg) Horse Ry. Co.—Dir R. Drewsko; 14.4 m; 18 c, 28 c.
Great Berlin Horse Ry. Co.—Dir Fischer-Diek; 104.54 m; 57 c, 2,633 h.
Now Berlin Horse Ry. Co.—Dir Gerth; 14.83 m; 73 c, 235 h.
Breslau (390,000). Breslau Ry. Co.—Dir G. M. Th. Weinberg; 14.3 m; 11 c, 24 h.
Chemnitz (100,000). Chemnitz Ry.—Dir Th. Franke; 5.713 m; 21 c, 62 h.
Dortmund St. Ry.—Dir & Engr H. From; 13.891 m; 27 c, 57 h, 7 1/2 m tr.
Dresden (390,000). Dresden Ry. Co.—Dir & Engr Lach; 6.38 m; 11 c, 24 h, 11 1/2 m tr.
D. M. Gluehach-Rheviat.—Dir & Engr Schmitt; 8.852 m; 16 c, 44 h.
Bremen (115,000). Bremen Horse Ry. Co.—Anzeiger-Bau; 4.300 m; 19 c, 40 h.
Bremen (115,000). Bremen Ry. Co.—Dir H. Niemann; 16.38 m; 35 c, 140 h.
Bremen Harbor St. Ry.—Inzeiger-Wingert; 4.197 m; 15 c, 49 h.
Breslau (390,000). Breslau Ry. Co.—Dir & Engr Weinberg; 11.382 m; 54 c, 210 h.
Brunswick (78,000). Brunswick St. Ry.—Dir G. R. Kunde; 6.02 m; 18 c, 75 h.
Cassel (58,314). Cassel City Ry.—Dir H. Scholten; 4.197 m; 16 c, 84 h.
Cologne (174,000). Cologne St. Ry. Co.—Dir & Engr W. Schmitt; 1.342 m; 2 c, 7 h.
Crefeld (138,866). Crefeld-Mording Street Ry.—Spt (of construction) Hoesfeld; 1.738 m; 9 c, 27 h.
Dantzig (114,000). Dantzig Street Ry.—Dir Oscar Kupferschmidt; 5.782 m; 27 c, 76 h.
Dresden (225,000). Dresden Tramway Co. of Germany (office London).—Dir O. M. P. Claus; 74.92 m; 102 c, 565 h.
Duesseldorf (95,000). Duesseldorf Tramway Co. (office Brussels).—Dir J. H. Muelner; 6.431 m; 18 c, 61 h.
Eingolstadt (15,000). Eingolstadt Tramway.—Proprietor H. Reuss; 2.2 m; 7 c, 17 h. (Carries freight and passengers.)
Erfurt (63,270). Erfurt St. Ry. Stock Co.—Dir E. W. Weinberg; 6.0 m; 60 h.
Flensburg (1,760). Flensburg Horse Ry.—1.552 m.
Frankfurt (145,000). Frankfurt Tramway Co.—Dir G. Bohringer (Frankfort-on-Main); 5.16 m; 16 c, 51 h.
Goerlitz (53,000). Goerlitz Street Ry. Co.—Dir C. Nicola; 4.4 m; 11 c, 38 h.
Hagen (84,335). Hagen St. Ry.—Dir Alex. von Stiehnagel; 4.965 m; 7 c, 28 h.
Halle (80,000). Halle St. Ry. Co.—Dir Gade; 4.347 m; 20 c, 60 h.
Hamburg (288,859). Hamburg St. Ry. Co.—Dir J. A. Cullin; 62.391 m; 244 c, 912 h, 19 1/2 m tr.
Hamburg-Altona Horse Ry. Co.—Dir C. W. Gordon; 10.18 m; 37 c, 314 h.
Hanover (122,860). Hanover Tramway Co. of Germany.—Dir C. W. Gordon; 18.525 m; 63 c, 180 h.
Hanover-Vorort St. Ry. Co.—Dir & Engr Hensinger von Waldeck; 2.173 m; 2 c, 6 h.
Karlsruher (80,000). United Steam & Horse Ry. Co. of Karlsruhe, Muehburg and Durlach; Receivers Hoek & Herm-Schmidt; 18 m.
Kiel (44,000). Kiel St. Ry. Co.—1.525 m.
Koenigsberg (141,000). Koenigsberg Horse Ry. Co.—Dir Scheldel; 9.342 m; 76 c, 151 h.
Leipzig (149,081). Leipzig Tramways Co. (Lim.)—General direction, London.—Dir Engel Bernhart Hill; Dir Leipzig Reuter; 21.91 m; 92 c, 512 h.
Luebeck (51,000). Luebeck Horse Ry. Co.—Gus Mgr Dohm; 5.247 m; 16 c, 62 h.
Magdeburg (97,529). Magdeburg St. Ry.—Dir Kiltzing; 10.246 m; 40 c, 175 h.
Mayence (60,000). Mayence St. Ry. Stock Co.—Dir Fr. Schimanski; 5.559 m; 30 c, 100 h.
Mannheim (48,000). Mannheim Ludwigshafen Tramway.—Dir Emil Reitzschke; Mannheim; 5.277 m; 17 c, 49 h.
Mecklenburg (42,000). Mecklenburg St. Ry. Stock Co. of Rostock and Schwerin.—Dir Oscar Otto, Berlin, 4.965, 2.484 m; 17 c, 52 h.
Metz (53,107). Metz Soc. Anon. des Tramways de Metz (Anonymous Asso. of Metz Tramways).—Dir C. W. Bohm; 7.762 m; 20 c, 70 h.
Munich (230,023). Munich Tramway Stock Co.—Dir E. Graziadei; 33.584 m; 135 c, 330 h.
Nurnberg (138,000). Nurnberg-Fuerth St. Ry. Co.—Engr & Dir Roth; 15.587 m; 46 c, 150 h.
Posen (65,000). Posen Horse Ry. Co.—Dir Belmer; 3.632 m; 20 c, 54 h.
Potsdam (48,000). Potsdam St. Ry. Co.—Dir Emil Bauer; 4.781 m; 29 c, 60 h.
Pyrmont (1,500). Pyrmont St. Ry. Stock Co.—Aus G. Steinhilber; 2.484 m; 5 c, 12 h.
Saarbr (18,000). Saarlouis St. Ry. Co.—Dir Ph. Schmidt; 1.7 m; 16 c, 25 h.
Strasbourg (111,000). Strasbourg St. Ry. Co.—Engr & Dir Alfred Noirel; 16.17 m; 96 c, 20 1/2 m tr.
Stuttgart (117,000). Stuttgart Horse Ry. Co.—Dir George Dielke; 6.392 m; 39 c, 82 h.
Fornesch (5,000). Fornesch-Netersen Horse Ry. (City of Netersen, Holstein); 1.05 m.
Wiesbaden (56,000). Wiesbaden Horse Ry. Co.—Dir Voss; 2.40 m; 12 c, 27 h.

AUSTRIA-HUNGARY.

Arad (33,000). Arad St. Ry. Co.—Dir Ludwig Dengner; 8.456 m; 14 c, 20 h.
Baden (5,847). Baden Tramway Co.—Engr W. Tedesco (Baden near Vienna).
Buda (300,000). Buda-Pesth St. Ry. Co.—Dir Henri Jelinek; 45.357 m; 278 c, 340 h.
Graz (95,000). Graz Tramway.—Dir Jacob Markbretter; 7 m; 30 c.
Lemberg (104,000). Lemberg Tramway.—Dir Julius Schuster; 15 m; 28 c, 116 h.
Linz (60,000). Linz St. Ry. Co.—Dir Ph. Schmidt; 1.7 m; 16 c, 25 h.
Pest (10,000). Pest-Palota St. Ry.—2.746 m; 13 c.
Prague (196,000). Prague Tramway.—Dir Constant De Preter; 82.649 m; 85 c, 107 h.
Temesvar (33,000). Temesvar St. Ry. Co.—Engr Heinrich Boudier; 6.006 m; 21 c, 69 h.
Trieste (127,000). Trieste Tramway Co.—Dir J. Fanta; 69.3 m; 561 c, 1,821 h.
Vienna (1,020,770). New Vienna Tramway Co.—Engr A. Pastorelli; 21 m; 66 c, 160 h.

NETHERLANDS.

Amsterdam (370,000). Amsterdam Omnibus Co.—Dir K. H. Sebodd; 12.839 m; 178 c, 600 h.
Arnhem (43,000). Arnhem Tramway Co.—15 c, 62 h.
Dordrecht (29,000). Dordrecht Tramway.—C. Kippers; 3 c, 6 h.
Gulnekken-Breda (23,000). Gulnekken-Breda Tramway Co.—Dir M. A. Kuytjen-Grover; 2.446 m.
Groninger (40,000). Groninger Tramway Co.—Vanland; 1.7 m; 13 c, 39 h.
Groninger (40,000). Soc Anon des Tramways de Groninger.—3.042 m; 7 c, 16 h.
Haarlem (157,000). Haarlem St. Ry. Co.—Dir E. Elzinga; 24.9 m; 82 c, 280 h.
Haarlem (37,000). Haarlem Tramway Co.—Dir J. H. Van West, Jr.; 1.1 m; 10 c, 10 h.

Leiden (42,000). Leiden Tramway Co. (Office, London).—Dir Fryman, s'Gravenhage; 10 r, 10 h.
Mittelsche Tramway Co. of Utrecht; Dir W. J. Vlasser; 7.927 m; 14 c, 45 h.
Rotterdam (152,817). Rotterdam, Hildersberg-Schiedamsdijk Tramway Co.—Dir H. Y. Schimmins; 2.699 m, 6 c, 20 h.
Rotterdam Tramway Co.—Dir H. P. Gieckert; 11.40 m, 40 c, 206 h.
Zeeuwsche Dierberg (Antwerp) Tramway.—W. J. Vlasser; Utrecht; 3 r, 5 h.
Utrecht (69,667). Netherlands Tramway Co. of Utrecht.—Dir H. Hannekelt; 50.3 m, 24 c, 10 h.

SWITZERLAND.

Basle (42,000). Basle Tramway Co.—Promotor J. Mettelm; 8 r, 60 h.
Geneva (146,783). Comp. Gen. of Swiss Tramways; Engr T. Laval; 12.998 m; 51 c, 162 h, 1 1/2 m tr.
Hochrhein (12,000). Tramway Co.—Engr T. Laval; 2.949 m; 7 c, 15 h.
Zurich (21,199). Zurich St. Ry. Stock Co.—GM Th. Kubli; 7.415 m; 30 c, 104 h.

BELGIUM.

Antwerp (—). National Tramways of Antwerp.—Dir Vander Moeren.
Tramways of North Antwerp.—Dir Gallez.
Brussels (389,782). Tramways of Brussels.—Dir H. G. Michelet, Engr F. Nonnenberg, Chief of Technical Service.
General Company of Railway.—Dir de Backer.
Company of Secondary Ry.—Dir A. Joquist, Engr A. Spee.

FRANCE.

Belms (81,328). Tramways of Belms.—Dir H. Thomas.
Houen (104,902). Houen Tramways s'c 156 Rue Beaumont, Houen.—38 c, 155 h.
Zeeuwsche Dierberg (Antwerp) Tramway.—W. J. Vlasser; Utrecht; 3 r, 5 h.
Zurich (21,199). Zurich St. Ry. Stock Co.—GM Th. Kubli; 7.415 m; 30 c, 104 h.

ITALY.

Brescia (38,000). Tramways of Brescia.—Engr A. Spee (Brussels).
Milan (285,543). The Lombardy Road Railway Co., Ltd (4 Cornhill Building, E. C. London, Eng., and 42 Via Carlo Farini, Milan); 15 km; 45 c, 54 wagons.

DENMARK.

Copenhagen (273,223). Nordrethors Sporvejselskab (Nordrethorsgade 198, N.).—Dir C. V. Wolfhagen, Sec C. Jacobsen, Spt C. Larsen; 3153 metres (—3750 yards), 4-11 g, 65 1/2 lbs; 25 c, 145 h.
Forstaderens Sporvejselskab.

NORWAY.

Christiania (124,155). Tramways of Christiania.—Dir M. Vogt.

RUSSIA.

Khar'kov (—). The Tramways of Khar'kov.—W. Hammerlath, Sec of Administration.
Moscow (—). The Tramways of Moscow and Russia.—Sec Mr. Hammerlath.
Odessa (—). Tramways of Odessa.—Engr M. Bourson, Brussels.
Warsaw (—). Dir de Backer, Brussels.

SPAIN.

Madrid (397,861). Madrid St. Tramways.—Owned by the Tramways Union Co. Lim., London.—6.5 m; 55 c, 297 h.

ROUMANIA.

Bucharest (221,805). Biharest Tramways.—Owned by the Tramways Union Co. Lim., London.—Sec J. E. Walker, GM G. W. Webb; 10.5 m; 42 c, 169 h.

INDIA.

Calcutta (871,504). The Calcutta Tramways Co. Lim. (11 Abchurch Lane, E. C. London, Eng.).—Chr E. C. Morgan, Sec Chas. Aker, Engr Geo. Hopkins, C. E.; Managing agent in Calcutta J. R. Napier; 19.5 m, 150 c, 662 h, 9 1/2 m tr.

AUSTRALIA.

NEW SOUTH WALES.

Melbourne (250,836). The Melbourne Tr. Co.—Engr Geo. Duncaas; 34 m (10 m cable road in operation).
Sydney (232,133). The Sydney Cable Tr. Co.—3.5 m (cable).

STRIKES are being played out, and the majesty of the law now ventures to put them down. At New York, Sep. 29th, Judge Barrett, of the supreme court, gave expression to his views upon strikes in an opinion which he rendered concerning the discharge of a prisoner arrested last April, charged with unlawful conspiracy in instigating a strike in the shoe factories of John H. Hanan, at Centre and White streets, and Gardner & Estes at Ninth avenue and Hudson street. The decision practically passes upon the cases of a half-dozen Knights of Labor who were arrested at the same time. Judge Barrett expresses his views upon the rights of employer and employee, and says: "The result of my examination of these papers is that a prima facie case has been made out sufficient to put the rioters on trial, or rather to justify the submission of the facts to the grand jury. It is true that an absolute scale of wages can not be effectively maintained as long as persons outside of the combination work for less than the fixed rate. Yet such persons have a perfect right to so work, and are entitled to protection against lawlessness—that is, the protection, not against the peaceable strike, but against violence or threats of violence. Where, however, there is no relation, direct or indirect, between wages and strike, the combination which brings the latter about for unlawful purposes is a criminal conspiracy. The strike then involves a diminishing of the quantity of productive labor, which is an injury to the community and an act injurious to trade. The unlawful purposes may also be evidenced by force, threats, or intimidation to prevent another from exercising a lawful trade or calling."





# TRADE DIRECTORY

CORRECTED MONTHLY.

## AMBULANCE CAINS (For Horses).

**BROOKLYN RAILWAY SUPPLY CO.** (The), 44 Wallworth st., Brooklyn, N. Y.

## AXLES.

**ANDREWS, FRANK H.**, 545 W. 33rd st., New York (side Brakes).

**BALTIMORE CAR WHEEL CO.** (The), Fulton Junction, Baltimore, Md., U. S. A. (Agents—W. S. Grayson & Co., Chicago and St. Louis; W. S. Gray Baker, care of Brown, Shipley & Co., Lothbury, E. C., London, England).

**BENT'S CAR HOX** 40, Springfield, Mass.

**BOWLER & CO.**, Cleveland, O. (Agents—J. G. Co., Philadelphia).

**BROWNELL & WIGHT CAR CO.**, 2300 Broadway, St. Louis, Mo.

**Cambria Iron Co.**, 218 S. Fourth st., Philadelphia; works at Johnstown, Pa. (Branches—No. 18 Wall st., New York; Mordecai Block, Chicago, Ill.)

**Carnegie, Phlips & Co.**, Limited, 48 Fifth ave., Pittsburgh, Pa.

**Dederick, Z. P.**, Sherman, Texas, Post Office, Cleveland, O.

**FULTON FOUNDRY** (S. M. Carpenter, proprietor), 432 E. 10th st., Cleveland, O. (Agent—Thos. C. White, 107 S. 8th st., St. Louis, Mo.)

**Griffin Wheel & Foundry Co.**, Lohsey st. and Blue Island ave., Chicago, Ill. and Buffalo, N. Y.

**Howard, Childs & Co.**, Hamilton Building (rooms 607 and 608) Phlox Bldg., Chicago, Ill.

**Laclede Car Co.**, 4500 N. Second st., St. Louis, Mo.

**LEWIS & FOWLER MANUFACTURING CO.** (The), 27 to 35 Walworth st., Brooklyn, N. Y.

**Meyensberg, O. W.**, & Co., 304 N. 3d st., St. Louis, Mo. (Branch—Phenix Bldg., Chicago, Ill.)

**Possydenman, W. C.**, 308 S. 4th st., Philadelphia. (Works at Steitton, Dauphin Co., Pa.)

**PUGH & RUSSELL**, Stewart Bldg., New York; Phenix Bldg., Chicago, Ill.

**STEPHENSON (JOHN) COMPANY**, Lim., 47 E. 27th st., New York. (Branch—Phenix Bldg., Chicago, Ill.)

**STREET RAILWAY SUPPLY CO.**, Cleveland, Ohio.

**WHITNEY, A. & SONS**, Philadelphia, Pa.

## BARRED WIRE.

**Cambria Iron Co.**, 218 S. 4th st., Philadelphia (side Axles).

## BEARINGS.

**ADAMS & WESTLAKE CO.** (The), 110 Ontario st., Chicago; 115 Broadway, New York.

**Alax Metal Co.** (The), 2040 N. Tenth st., Philadelphia.

**American Bearing Works**, 46 Columbus st., Cleveland, O.

**ANDREWS, FRANK H.**, 545 W. 33rd st., New York (side Brakes).

**BALTIMORE CAR WHEEL CO.** (The), Baltimore, Md. (side Axles).

**BENT'S CAR HOX** 40, Springfield, Mass.

**BRILL (J. G.) Co.**, Philadelphia.

**BROWNELL & WIGHT CAR CO.**, 2300 Broadway, St. Louis, Mo.

**Chapin Manufacturing Co.**, 69 Wall st., New York.

**Danasusac Bronze Co.**, Pittsburgh, Pa.

**Dederick, Z. P.**, Sherman, Texas.

**Fulton Foundry**, Cleveland, O. (side Axles).

**Griffin Wheel & Foundry Co.**, Lohsey st. and Blue Island ave., Chicago, Ill.

**Keystone Smelting Co.** (The) Limited, 33d st., Pittsburgh, Pa.

**Laclede Car Co.**, 4500 N. Second st., St. Louis, Mo.

**LEWIS & FOWLER MANUFACTURING CO.** (The), 27 to 35 Walworth st., Brooklyn, N. Y.

**MARTIN, RUFUS & CO.**, 13 Park Row, New York. (Branch—Wichita Construction and Supply Co., Wichita, Kan.)

**Menely, Geo. H.**, & Co., West Troy, N. Y. (Branch—Atlanta, Ga.)

**Meyensberg, O. W.**, & Co., 214 N. 3d st., St. Louis, Mo. (Branch—Phenix Bldg., Chicago, Ill.)

**Miller, Chas. B.**, 310 E. 14th st., New York.

**Phosphor Bronze Smelting Co.** (The), Limited, 512 10th st., Philadelphia.

**PUGH & RUSSELL**, Stewart Bldg., New York; Phenix Bldg., Chicago, Ill.

## BELLS.

**MARTIN, RUFUS & CO.**, 13 Park Row, New York. Post Office, Cincinnati, O.

**Star Bell Co.**, Eastampton, Mass.

**W. DUDEN & TIFT**, 102 and 104 E. Second st., Cincinnati, O.

## BELTING.

**Page Belting Co.**, Concord, N. H. (Branches—11 Federal st., Boston, Mass.; 161 Lake st., Chicago; 4th and St. Charles st., St. Louis, Mo.; 1307 W. 13th st., Kansas City, Mo.)

**Scotch Belting Co.**, St. Louis, Mo. (Branches—Curts & Co. Mfg. Co., 60 W. Monroe st., Chicago; Jas. Garnett, Philadelphia; Frank Petree, Boston, Mass.)

## BENDING MACHINES.

**Avres, Abraham**, 518 W. 4th st., New York.

**BROOKLYN RAILWAY SUPPLY CO.** (The), 44 Wallworth st., Brooklyn, N. Y.

**Chester Steel Castings Co.**, 407 Library st., Philadelphia. (Works—Chester, Pa.)

**Craig, Wm. F.**, 95 Liberty st., New York.

**Grooley, The E. S. & Co.**, 5 and 7 Day st., New York.

**Harris, T. Wm.**, & Co., 2 Nassau st. (room 17), New York.

**Howard, Childs & Co.**, Hamilton Building, Pittsburgh.

**LEWIS & FOWLER MANUFACTURING CO.** (The), 27 to 35 Walworth st., Brooklyn, N. Y.

**PUGH & RUSSELL**, Stewart Bldg., New York; Phenix Bldg., Chicago, Ill.

**Wm. Wharton, Jr., & Co.** (Incorporated), 25th st. and Washington ave., Philadelphia, Pa.

## BOLTS.

**Dayton, L. M.**, Cincinnati, O.

## BRACKES.

**JOHNSON STEEL, STREET RAIL CO.** (The), Johnston, Pa. (side Cable Yokes).

**DICKSON, C. K.**, Sec'y Northern Central Ry. Co., St. Louis, Mo.

## BRAKE CHAINS.

**ROBBINSON SONS CO.**, JOHN A., Trenton, N. J. (Branches—17 and 19 Liberty st., New York; 171 and 173 Lake st., Chicago; 14 Drum st., San Francisco, Cal.)

## BRACE HANDLES.

**BRILL (J. G.) Co.**, Philadelphia.

**MARTIN, RUFUS & CO.**, 13 Park Row, New York.

**STEPHENSON (JOHN) COMPANY**, Limited, 47 E. 27th st., New York. (Branch—Phenix Bldg., Chicago, Ill.)

## BRAKE ROIDS.

**BRILL (J. G.) Co.**, Philadelphia.

**Dederick, Z. P.**, Sherman, Texas.

**Howard, Childs & Co.**, Hamilton Building, Pittsburgh.

**Laclede Car Co.**, 4500 N. Second st., St. Louis, Mo.

**LEWIS & FOWLER MFG CO.** (The), 27 to 35 Walworth st., Brooklyn, N. Y.

**MARTIN, RUFUS & CO.**, 13 Park Row, New York.

**PUGH & RUSSELL**, Stewart Bldg., New York; Phenix Bldg., Chicago, Ill.

**STEPHENSON (JOHN) COMPANY**, Limited, 47 E. 27th st., New York. (Branch—Phenix Bldg., Chicago, Ill.)

**ANDREWS, FRANK H.**, 545 W. 33rd st., New York. (Works—535 to 551 West 33rd st.; 538 to 552 W. 34th st., New York. Branches—37 Central st., Boston; Lakeville Building, Chicago; Southern Hotel, St. Louis; Agents—Wm. B. Isaacs, 258 Market st., San Francisco, Cal.; Bacon Bros., 377 St. Paul st., Montreal, Can.)

**BRILL (J. G.) Co.**, Philadelphia.

**BROWNELL & WIGHT CAR CO.**, 2300 Broadway, St. Louis, Mo.

**Dederick, Z. P.**, Sherman, Texas.

**Howard, Childs & Co.**, Hamilton Building, Pittsburgh.

**Laclede Car Co.**, 4500 N. Second st., St. Louis, Mo.

**LEWIS & FOWLER MFG. CO.** (The), 27 to 35 Walworth st., Brooklyn, N. Y.

**MARTIN, RUFUS & CO.**, 13 Park Row, New York.

**PUGH & RUSSELL**, Stewart Bldg., New York; Phenix Bldg., Chicago, Ill.

**STEPHENSON (JOHN) COMPANY**, Limited, 47 E. 27th st., New York. (Branch—Phenix Bldg., Chicago, Ill.)

**Wilson, Mordecai M.**, (Agent), Troy, N. Y.

## BRAKE SHOES.

**ANDREWS, FRANK H.**, 545 W. 33rd st., New York. (side Brakes).

**Avres, Abraham**, 503 to 518 W. 45th st., New York.

**BALTIMORE CAR WHEEL CO.** (The), Baltimore, Md. (side Axles).

**BRILL (J. G.) Co.**, Philadelphia.

**BROWNELL & WIGHT CAR CO.**, 2300 Broadway, St. Louis, Mo.

**Chester Steel Castings Co.**, 407 Library st., Philadelphia.

**Dederick, Z. P.**, Sherman, Texas.

**Fulton Foundry**, Cleveland, Ohio (side Axles).

**Grooley, The E. S. & Co.**, 5 and 7 Day st., New York.

**Griffin Wheel & Foundry Co.**, Lohsey st. and Blue Island ave., Chicago, Ill.

**Howard, Childs & Co.**, Hamilton Building, Philadelphia.

**LEWIS & FOWLER MFG. CO.** (The), 27 to 35 Walworth st., Brooklyn, N. Y.

**MARTIN, RUFUS & CO.**, 13 Park Row, New York.

**PUGH & RUSSELL**, Stewart Bldg., New York; Phenix Bldg., Chicago, Ill.

**STEPHENSON (JOHN) COMPANY**, Limited, 47 E. 27th st., New York. (Branch—Phenix Bldg., Chicago, Ill.)

**Wm. Wharton, Jr., & Co.** (Incorporated), 25th st. and Washington ave., Philadelphia, Pa.

**Whiting Mfg. Co.**, Cedar Rapids, Iowa.

**WHITNEY, A. & SONS**, Philadelphia, Pa.

## BRASS AND BRONZE.

**BROOKLYN RAILWAY SUPPLY CO.** (The), 44 Wallworth st., Brooklyn, N. Y.

**MARTIN, RUFUS & CO.**, 13 Park Row, New York.

**STEPHENSON (JOHN) COMPANY**, Limited, 47 E. 27th st., New York. (Branch—Phenix Bldg., Chicago, Ill.)

**HAZARD MFG. CO.**, Wilkes Barre, Pa. (Branches—14 Terrace, Buffalo, N. Y.; 159 River st., Cleveland, O.; 24 Commercial st., Boston, Mass.; 25 Route 107 st., Baltimore, Md.; 259 E. Main st. and Lake City, Utah; 216 Lake st., Chicago, Ill.; 59 E. 11th ave., Pittsburgh, Pa.; 21 Fremont st., San Francisco, Cal.; 703 Market st., Philadelphia, Pa.; 35 S. Delaware ave., Philadelphia, Pa.; 87 Liberty st., New York; Kansas City, Mo.; St. Louis, Mo.; Cincinnati, O.)

**Howard, Childs & Co.**, Hamilton Building, Pittsburgh.

**JOHNSON, THOMAS L.**, Johnston, Pa. (Incorporated), Post & Company, Cincinnati, Ohio.

**ROBBINSON SONS CO.**, JOHN A., Trenton, N. J. (Branches—17 and 19 Liberty st., New York; 171 and 173 Lake st., Chicago; 14 Drum st., San Francisco, Cal.)

**WALKER & MOEN MANUFACTURING CO.**, Worcester, Mass. (Warehouses—18 Cliff st., New York; 107 and 109 Lake st., Chicago.)

## CABLE SHEAVES.

**HOPEINGHOFF & LAUE**, Cincinnati, O.

**St. Louis Machine Iron Works**, St. Louis, Mo.

**WAY FOUNDRY CO.** (The), 23d and Wood sts., Philadelphia, Pa.

## CABLE YOKES.

**BALTIMORE CAR WHEEL CO.** (The), Baltimore, Md. (side Axles).

**BRILL (J. G.) Co.**, Philadelphia.

**HOPEINGHOFF & LAUE**, Cincinnati, O.

**HORACE A. KEEFER CO.** (The), Kansas City, Mo.

**JOHNSON STEEL SHEET FABR. CO.** (The), Johnston, Pa. (Incorporated), Post & Company, Cincinnati, O.

**New Orleans: Phoenix Building**, Chicago; Bank of Commerce Building, St. Louis, Mo.; 6 Oliver st., Boston; Newark Building, New York; Johnston Building, Cincinnati; 252 W. Main st., Louisville, Ky.

**Metallic Street Railway Supply Co.**, 37 State st., Albany, N. Y. (Agent—Elihu A. Noyes, 543 W. 23rd st., St. Louis, Mo.)

**St. Louis Machine Iron Works**, St. Louis, Mo.

**Union Foundry & Pullman Car Wheel Works**, Chicago. Wm. Wharton, Jr., & Co. (Incorporated), 25th st. and Washington ave., Philadelphia, Pa.

## CAR BUSH BEINS.

**BRILL (J. G.) Co.**, Philadelphia.

**BROWNELL & WIGHT CAR CO.**, 2300 Broadway, St. Louis, Mo.

**Dederick, Z. P.**, Sherman, Texas.

**Dick, Kerr & Co.**, 101 Leadenhall st., E. C. London.

**Works—Hirlanda Engineering Works, Kilmarnock, Scotland.**

**Falcon Engine & Car Works**, Limited, Loughborough, Eng. (London office—1 Coleman st., E. C.)

**Felgel Car Co.** (The), 108 Wall st., New York.

**Haines Bros.**, 55 Broadway, New York.

**James J. M. Sons**, West Chester, Ohio.

**KUHLMANN CAR CO.**, 490 E. Clair st., Cleveland, O.

**Laclede Car Co.**, 4500 N. Second st., St. Louis, Mo.

**Lancaster Wagon Co.** (The), Limited, Lancaster, Eng. (London office—Victoria st., Westminster, W. W.)

**Metropolitan Carriage and Wagon Works**, Birmingham, England.

**PUGH & RUSSELL**, Stewart Bldg., New York; Phenix Bldg., Chicago, Ill.

**PULLMAN PALACE CAR CO.**, Chicago; Pullman, Ill.; Detroit, Mich.

**Robinson & Hill**, Waterloo, Iowa.

**St. Louis Car Co.** (The), 5th Broadway, St. Louis, Mo.

**Starbuck Car and Wagon Co.** (The), Limited, Birkenhead, (London office—6 Gt. Winchester st., Buldware, E. C.)

**STEPHENSON (JOHN) COMPANY**, Limited, 47 E. 27th st., New York. (Branch—Phenix Bldg., Chicago, Ill.)

## CAR (Electric) BUILDERS.

**Glenshaw Electric Tramway** (W. A. Traill, Engineer), Co. Arthur, Pa.

## CAR CASTINGS.

**ADAMS & WESTLAKE CO.** (The), 110 Ontario st., Chicago, Ill. (Branch—115 Broadway, New York.)

**ANDREWS, FRANK H.**, 545 W. 33rd st., New York (side Brakes).

**Asham Bros. & Whison**, Limited, Sheffield, England.

**Avres, Abraham**, 503 to 518 W. 45th st., New York.

**BALTIMORE CAR WHEEL CO.** (The), Baltimore, Md. (side Axles).

**BROWNELL & WIGHT CAR CO.**, 2300 Broadway, St. Louis, Mo.

**Chester Steel Castings Co.**, 407 Library st., Philadelphia.

**Craig, Wm. F.**, 95 Liberty st., New York.

**Dederick, Z. P.**, Sherman, Texas.

**FULTON FOUNDRY**, Cleveland, O. (side Axles).

**Howard, Childs & Co.**, Hamilton Building, Pittsburgh.

**Kaestner, Chas., & Co.**, 303 S. Canal st., Chicago, Ill.

**Keystone Smelting Co.** (The), Limited, 33rd st., Pittsburgh, Pa.

**Laclede Car Co.**, 4500 N. Second st., St. Louis, Mo.

**LEWIS & FOWLER MFG. CO.** (The), 27 to 35 Walworth st., Brooklyn, N. Y.

**MARTIN, RUFUS & CO.**, 13 Park Row, New York.

**Post & Company**, Cincinnati, Ohio.

**PUGH & RUSSELL**, Stewart Bldg., New York; Phenix Bldg., Chicago, Ill.

**S. N. E. & B.**, Louisville, Ky.

**STREET RAILWAY SUPPLY CO.**, Cleveland, Ohio.

**Wm. Wharton, Jr., & Co.** (Incorporated), 25th st. and Washington ave., Philadelphia, Pa.

**Whiting Mfg. Co.**, Cedar Rapids, Ia.

**WHITNEY, A. & SONS**, Philadelphia, Pa.

## CAR CEILINGS.

**ADAMS & WESTLAKE CO.** (The), 110 Ontario st., Chicago, Ill. (Branch—115 Broadway, New York.)

**BRILL (J. G.) Co.**, Philadelphia.

**BROWNELL & WIGHT CAR CO.**, 2300 Broadway, St. Louis, Mo.

**Dayton Mfg. Co.** (The), Dayton, Ohio.

**Dederick, Z. P.**, Sherman, Texas.

**Frost & Peterson**, New York.

**GARDNER & CO.**, 47 W. 42nd st., New York. (Factory 100 to 657 W. 4th st., New York.)

**Greely, The E. S. & Co.**, 5 and 7 Day st., New York.

**KUHLMANN CAR CO.**, 490 E. Clair st., Cleveland, O.

**Laclede Car Co.**, 4500 N. Second st., St. Louis, Mo.

**PUGH & RUSSELL**, Stewart Bldg., New York; Phenix Bldg., Chicago, Ill.

**Purdy & Huntington**, Co., Lim., 60 Shoe Lane, London.

## CAR COUPLERS.

**Sargent, W. W.**, Pittsburg, Mass.



**CAR HEATER FITTINGS (Hose, &c.)**  
Gold, Edw. L., & Co., ne. cor. Frankfort and Cliff sts., New York.

Greely, The E. S., & Co., 5 and 7 DeY st., New York.

**CAR HEATERS.**  
ADAMS & WESTLAKE CO. (The), 110 Ontario st., Chicago, 115 Broadway, New York.  
Brill (J. G.) Co., Philadelphia.  
CLINE MFG. CO., 277 and 279 S. Canal st., Chicago.  
Clute, Geo. M., West Troy, N. Y.  
Gold, Edw. L., & Co., ne. cor. Frankfort and Cliff sts., New York.

Greely, E. S., & Co., 5 and 7 DeY st., New York.  
Laclede Car Co., 4500 N. Second st., St. Louis, Mo.  
LEWIS & FOWLER MFG. CO. (The), 27 to 35 Walworth st., Brooklyn, N. Y.

MARTIN, RUFUS, & Co., 13 Park Row, New York.  
Missouri and Kansas Lumber and Fuel Co., 219 and 221 Market st., St. Louis, Mo.

PENN YUICK HEAT & VENTILATION CO., 12 Pearl st., Boston.  
Post & Company, Cincinnati, Ohio.  
PUGH & RUSSELL, Stewart Bldg., New York; Phenix Bldg., Chicago, Ill.

STEPHENSON (JOHN) COMPANY, Limited, 47 E. 27th st., New York. (Branch—Phenix Bldg., Chicago.)  
STREET RAILWAY SUPPLY CO., Cleveland, Ohio.

**CAR LAMPS.**  
ADAMS & WESTLAKE CO. (The), 110 Ontario st., Chicago, 115 Broadway, New York.  
Brill (J. G.) Co., Philadelphia.  
BROWNELL & WIGHT CAR CO., 2300 Broadway, St. Louis, Mo.

Clute, Geo. M., West Troy, N. Y.  
Dayton Mfg. Co. (The), Dayton, Ohio.  
Dederick, Z. P., Sherman, Texas.

FULTON FOUNDRY, Cleveland, O. (vide Axles).  
Greely, The E. S., & Co., 5 and 7 DeY st., New York.  
Laclede Car Co., 4500 N. Second st., St. Louis, Mo.

MARTIN, RUFUS, & Co., 13 Park Row, New York.  
Miller, Chas. B., 310 E. 14th st., New York.  
Post & Company, Cincinnati, Ohio.  
PUGH & RUSSELL, Stewart Bldg., New York; Phenix Bldg., Chicago, Ill.

STEPHENSON (JOHN) COMPANY, Limited, 47 E. 27th st., New York. (Branch—Phenix Bldg., Chicago.)  
SMITH, JOSEPHINE D., 350 Pearl st., New York.

**CAR MOUNTAINERS.**  
LANE & BODLEY CO. (The), 267 to 283 Water st., Cincinnati, Ohio.

**CARS (Sand and Salt).**  
BROOKLYN RAILWAY SUPPLY CO. (The), 44 Walworth st., Brooklyn, N. Y.

**CAR SASH.**  
Ayers' Patent Sash Holder Co., 242 Stewart Bldg., New York.  
Brill (J. G.) Co., Philadelphia.  
BROWNELL & WIGHT CAR CO., 2300 Broadway, St. Louis, Mo.

Dayton Mfg. Co. (The), Dayton, Ohio.  
Dederick, Z. P., Sherman, Texas.  
Greely, The E. S., & Co., 5 and 7 DeY st., New York.

KULMANN CAR CO., 490 St. Clair st., Cleveland, O.  
Laclede Car Co., 4500 N. Second st., St. Louis, Mo.  
MARTIN, RUFUS, & Co., 13 Park Row, New York.  
PUGH & RUSSELL, Stewart Bldg., New York; Phenix Bldg., Chicago, Ill.

STEPHENSON (JOHN) COMPANY, Limited, 47 E. 27th st., New York. (Branch—Phenix Bldg., Chicago.)

**CAR SEATS.**  
ADAMS & WESTLAKE CO. (The), 110 Ontario st., Chicago, 115 Broadway, New York.  
Brill (J. G.) Co., Philadelphia.  
BROWNELL & WIGHT CAR CO., 2300 Broadway, St. Louis, Mo.

Dayton Mfg. Co. (The), Dayton, Ohio.  
Dederick, Z. P., Sherman, Texas.  
Frost & Peters, 65 W. 4th st., New York.

Gardner & Co., 643 to 657 W. 48th st., New York.  
Greely, The E. S., & Co., 5 and 7 DeY st., New York.  
Hale & Kilmer, 40 (The), 48 and 50 N. 6th st., Philadelphia.

HARTFORD WOVEN WIRE MATTRESS CO. (The), Postoffice box 363, Hartford, Conn.  
KULMANN CAR CO., 490 St. Clair st., Cleveland, O.  
Laclede Car Co., 4500 N. Second st., St. Louis, Mo.

MARTIN, RUFUS, & Co., 13 Park Row, New York.  
Post & Company, Cincinnati, Ohio.  
PUGH & RUSSELL, Stewart Bldg., New York; Phenix Bldg., Chicago, Ill.

Purdy & Huntington Co., Limited, 60 Shoe Lane, E. C., London.  
STEPHENSON (JOHN) COMPANY, Limited, 47 E. 27th st., New York. (Branch—Phenix Bldg., Chicago.)

Wakenfield Rattan Co., Boston, Mass. (Branches—644 Market st., San Francisco; 143 and 146 Wabash av., Chicago; 924 Broadway, and 8 Park pl., New York.)

**CARS (Second Hand).**  
Brill (J. G.) Co., Philadelphia.  
BROOKLYN RAILWAY SUPPLY CO. (The), 44 Walworth st., Brooklyn, N. Y.

BROWNELL & WIGHT CAR CO., 2300 Broadway, St. Louis, Mo.  
Greely, The E. S., & Co., 5 and 7 DeY st., New York.  
Hampreys & Sayce, 1 Broadway, New York.

MARTIN, RUFUS, & Co., 13 Park Row, New York.  
PUGH & RUSSELL, Stewart Bldg., New York; Phenix Bldg., Chicago, Ill.

**CAR SHEDS AND STABLES.**  
Evaus, H. D., Sainsbury Works, Horsley Rise, N. London.

**CAR SIGNALS.**  
Brill (J. G.) Co., Philadelphia.  
MARTIN, RUFUS, & Co., 13 Park Row, New York.

**CAR SPRINGS.**  
ANDREWS, FRANK H., 545 W. 33rd st., New York (vide Brakes).  
BALTIMORE CAR WHEEL CO. (The), Baltimore, Md. (vide Axles).

BENIS CAR BOX CO., Springfield, Mass.  
Brill (J. G.) Co., Philadelphia.  
BROWNELL & WIGHT CAR CO., 2300 Broadway, St. Louis, Mo.

Clute, Geo. M., West Troy, N. Y.  
Diamond State Car Spring Co., 8th and Railroad av., Wilmington, Del.  
Foote, Orlo A., Grand, O.

French, A. A., Car Spring Co., 189 W. 1st st., New York.  
Greely, The E. S., & Co., 5 and 7 DeY st., New York.  
Howard, Childs Co., Hamilton Bldg., Pittsburgh, Pa.

LEWIS & FOWLER MFG. CO. (The), 27 to 35 Walworth st., Brooklyn, N. Y.

MARTIN, RUFUS, & Co., 13 Park Row, New York.  
Picking Spring Co., Limited, Philadelphia, Pa.

STEPHENSON (JOHN) COMPANY, Limited, 47 E. 27th st., New York. (Branch—Phenix Bldg., Chicago.)  
STREET RAILWAY SUPPLY CO., Cleveland, Ohio.

VON RICHARD, 13 Park Row, New York. (Branches—104 N. 3rd st., St. Louis; 117 Adams Express Bldg., Chicago, Ill.)

**CAR STARTERS.**  
BAKER, W. S. GRAFF, care Brown, Shipley & Co., Lothbury, E. C., London, Eng.; and postoffice box 176, Baltimore, Md.

BALTIMORE CAR WHEEL CO. (The), Baltimore, Md. (vide Axles).  
Broadway, E. C., 169 Laurel st., New Orleans, La.  
Chester Steel Castings Co., 407 Library st., Philadelphia.

Greely, The E. S., & Co., 5 and 7 DeY st., New York.  
PUGH & RUSSELL, Stewart Bldg., New York; Phenix Bldg., Chicago, Ill.  
Wiser & Vail, 272 Pearl st., Cleveland, Ohio.

**CAR STOOLS.**  
Haddox, W. O., Louisville, Ky.

**CAR TRIMMINGS.**  
ADAMS & WESTLAKE CO. (The), 110 Ontario st., Chicago, 115 Broadway, New York.  
Brill (J. G.) Co., Philadelphia.  
BROWNELL & WIGHT CAR CO., 2300 Broadway, St. Louis, Mo.

Dayton Mfg. Co. (The), Dayton, Ohio.  
Foote, Orlo A., Cleveland, O.  
Greely, The E. S., & Co., 5 and 7 DeY st., New York.

Laclede Car Co., 4500 N. Second st., St. Louis, Mo.  
LEWIS & FOWLER MFG. CO. (The), 27 to 35 Walworth st., Brooklyn, N. Y.

MARTIN, RUFUS, & Co., 13 Park Row, New York.  
Miller, Chas. B., 310 E. 14th st., New York.  
Post & Company, Cincinnati, Ohio.

PUGH & RUSSELL, Stewart Bldg., New York; Phenix Bldg., Chicago, Ill.  
STEPHENSON (JOHN) COMPANY, Limited, 47 E. 27th st., New York. (Branch—Phenix Bldg., Chicago.)

SMITH, JOSEPHINE D., 350 Pearl st., New York.  
Stewart & Mattson Mfg. Co. (The), 2042 N. 10th st., White Edw. C., 531 W. 33rd st., New York.

**CAR WHEELS.**  
ANDREWS, FRANK H., 545 W. 33rd st., New York (vide Brakes).

BAKER, W. S. GRAFF, care Brown, Shipley & Co., Lothbury, E. C., London, Eng.; and postoffice box 176, Baltimore, Md.

BALTIMORE CAR WHEEL CO. (The), Baltimore, Md. U. S. A. (Agents—D. W. Meyenburg & Co., Chicago 20 St. Louis, Mo.; Brown, Shipley & Co., Lothbury, London, E. C., England); BENIS CAR BOX CO., Springfield, Mass.

BROWNELL & WIGHT CAR CO., 2300 Broadway, St. Louis, Mo.  
Brill (J. G.) Co., Philadelphia.  
BROWNELL & WIGHT CAR CO., 2300 Broadway, St. Louis, Mo.

Dayton Mfg. Co. (The), Dayton, Ohio.  
Dederick, Z. P., Sherman, Texas.  
Foote, Orlo A., Cleveland, O.

FULTON FOUNDRY, Cleveland, O. (vide Axles).  
Griffin, Thos. F., & Sons, Buffalo, N. Y.  
Griffin, Thos. F., & Sons, Buffalo, N. Y.

Griffin, Thos. F., & Sons, Buffalo, N. Y. (Branches—104 N. 3rd st., St. Louis, Mo.; Robey st. and Blue Island av., Chicago, Ill.)  
Hadfield's Steel Foundry Co., Acrefield, Sheffield, Eng.

HORACE A. KEEFER CO. (The), Kansas City, Mo.  
Howard, Childs Co., Hamilton Bldg., Pittsburgh, Pa.  
Knoxville Car Wheel Co., Knoxville, Tenn.

Laclede Car Co., 4500 N. Second st., St. Louis, Mo.  
LEWIS & FOWLER MFG. CO. (The), 27 to 35 Walworth st., Brooklyn, N. Y.

MARTIN, RUFUS, & Co., 13 Park Row, New York.  
Meyenburg, O. W., & Co., 204 N. 3d st., St. Louis, Mo. (Branch—Phenix Bldg., Chicago, Ill.)

Mitchell & Co., London and Foundry, Edinburgh, Scot.  
Peckham Car Wheel Co. (The), Syracuse, N. Y.  
PUGH & RUSSELL, Stewart Bldg., New York; Phenix Bldg., Chicago, Ill.

STEPHENSON (JOHN) COMPANY, Limited, 47 E. 27th st., New York. (Branch—Phenix Bldg., Chicago.)  
St. Thomas Car Wheel Co., St. Thomas, Ont., Canada.  
STREET RAILWAY SUPPLY CO., Cleveland, Ohio.

WILSON, PEASE & CO., Middleborough-on-Tees, England.

**CEMENTS (For Cable Roads).**  
EMPIRE WAREHOUSE CO., 210 Market st., Chicago.

**CHAIRS.**  
JOHNSTON STEEL STREET RAIL CO. (The), Johnston, Pa. (vide Cable Yokes).  
Wilson, Pease & Co., Middleborough-on-Tees, England.

**CHANGE BELTS.**  
MARTIN, RUFUS, & Co., 13 Park Row, New York.

**CHANGE RECEPTABLES.**  
MASSON, MILTON L., Agent for Sawston's Patents, 365 Avenue A., New York.

WALSH MANUFACTURING CO., 76 and 78 E. Water st., Syracuse, N. Y.  
Whiting, T. J., 7a South Place, Flusbury, London.

**CHANNEL PLATES.**  
ANDREWS, FRANK H., 545 W. 33rd st., New York (vide Brakes).

Ayres, Abraham, 502 to 518 W. 45th st., New York.  
Craig, Wm. F., 95 Liberty st., New York, N. Y.

HORACE A. KEEFER CO. (The), Kansas City, Mo.  
Howard, Childs Co., Hamilton Bldg., Pittsburgh, Pa.  
JOHNSTON STEEL STREET RAIL CO. (The), Johnston, Pa. (vide Cable Yokes).

LEWIS & FOWLER MFG. CO. (The), 27 to 35 Walworth st., Brooklyn, N. Y.  
Meyenburg, O. W., & Co., 204 N. 3d st., St. Louis, Mo. (Branch—Phenix Bldg., Chicago, Ill.)

PUGH & RUSSELL, Stewart Bldg., New York; Phenix Bldg., Chicago, Ill.  
Wm. Wharton, Jr., & Co. (Incorporated), 25th st. and Washington av., Philadelphia, Pa.

**CHIMNEYS, BURNERS & WICKS.**  
ADAMS & WESTLAKE CO. (The), 110 Ontario st., Chicago, 115 Broadway, New York.  
Clute, Geo. M., West Troy, N. Y.

**CLUTCH AXLES.**  
BALTIMORE CAR WHEEL CO. (The), Baltimore, Md. (vide Car Wheels).  
Empire Axle Mfg. Co., 33 Nassau st., New York.

**COLORS.**  
GOFFIN, DEVOE & CO., 176 Randolph st., Chicago, Ill.  
Sherwin-Williams Co. (The), 100 Canal st., Cleveland, O. (Branches—24 Jackson st., Chicago, Ill.; 178 Fulton st., New York.)

**CONCRETE MIXERS.**  
Caldwell, H. W., 133 W. Washington st., Chicago.  
Kaestner Chms. & Co., 809 S. Canal st., Chicago, Ill.

**CONNECTING TRACKS.**  
JOHNSTON STEEL STREET RAIL CO. (The), Johnston, Pa. (vide Cable Yokes).

**CONTRACTORS AND BUILDERS.**  
ANDREWS, FRANK H., 545 W. 33rd st., New York (vide Brakes).

BAKER, W. S. GRAFF, care Brown, Shipley & Co., Lothbury, E. C., London (vide Car Starters).  
Cleveland Electric Motor Co. (Geo. W. Mansfield, Spt. and electrician), 1st National Bank Building, Cleveland, Ohio.

Craig, Wm. F., 95 Liberty st., Brooklyn, N. Y.  
Haines Bros., 55 Broadway, New York.  
Harris T. Wm. & Co., 2 Nassau st. (room 17), New York.

HATHAWAY & ROBINSON, 14 Case Bldg., Cleveland, O.  
HORACE A. KEEFER CO. (The), Kansas City, Mo.  
Hutchinson, A. J., 120 Broadway, New York.

LEWIS & FOWLER MFG. CO. (The), 27 to 35 Walworth st., Brooklyn, N. Y.  
Neffel & Oothout, 43 Liberty st., New York.  
New York Railway Supply Co., 42 Wall st., New York.

Raymond, James, 45 Broadway, New York.  
Wichita Construction and Supply Co. (The), Wichita, Kans.

Whites & Co., 17 Bishop's Gate, E. C., London.  
Wm. Wharton, Jr., & Co. (Incorporated), 25th st. and Washington av., Philadelphia, Pa.

Wright Construction Co., Phenix Bldg., Chicago.  
Wright, Meyenburg & Co., St. Louis, Mo.

**CONSTRUCTION CARS.**  
BROOKLYN RAILWAY SUPPLY CO. (The), 44 Walworth st., Brooklyn, N. Y.

**CROSSINGS.**  
ANDREWS, FRANK H., 545 W. 33rd st., New York (vide Brakes).

BALTIMORE CAR WHEEL CO. (The), Baltimore, Md. (vide Car Wheels).

Chester Steel Castings Co., 407 Library st., Philadelphia, Pa.  
Dederick, Z. P., Sherman, Texas.  
FULTON FOUNDRY, Cleveland, O. (vide Axles).

Greely, The E. S., & Co., 5 and 7 DeY st., New York.  
HORACE A. KEEFER CO. (The), Kansas City, Mo.  
Howard, Childs & Co., Hamilton Bldg., Pittsburgh, Pa.

JOHNSTON STEEL STREET RAIL CO. (The), Johnston, Pa. (vide Cable Yokes).  
Johnston RE, Frog & Switch Co., Chester, Pa.

LEWIS & FOWLER MFG. CO. (The), 27 to 35 Walworth st., Brooklyn, N. Y.

Meyenburg, O. W., & Co., 204 N. 3d st., St. Louis, Mo. (Branch—Phenix Bldg., Chicago, Ill.)  
Pennsylvania Steel & Foundry Co. (vide Axles).

PUGH & RUSSELL, Stewart Bldg., New York; Phenix Bldg., Chicago, Ill.  
SWEAD & HIBB, Knoxville, Ky.

WAY FOUNDRY CO. (The), 23d and Wood sts., Philadelphia, Pa.

WHITNEY, A. & SONS, Philadelphia, Pa.  
Wm. Wharton, Jr., & Co. (Incorporated), 25th st. and Washington av., Philadelphia, Pa.

**CROSSINGS (Cable and Electric Ry.)**  
Wm. Wharton, Jr., & Co. (Incorporated), 25th st. and Washington av., Philadelphia, Pa.

**CURVES.**  
WAY FOUNDRY CO. (The), 23d and Wood sts., Philadelphia, Pa.

**DOOR STOPS.**  
ADAMS & WESTLAKE CO. (The), 110 Ontario st., Chicago, 115 Broadway, New York.

Brill (J. G.) Co., Philadelphia, Pa.  
BROWNELL & WIGHT CAR CO., 2300 Broadway, St. Louis, Mo.

Greely, The E. S., & Co., 5 and 7 DeY st., New York.  
Hest & Doer Fastener Co., 115 E. Euclid av., Cleveland, Ohio.

Miller, Chas. B., 310 E. 14th st., New York.  
Post & Company, Cincinnati, Ohio.  
PUGH & RUSSELL, Stewart Bldg., New York; Phenix Bldg., Chicago, Ill.

**DRAW HEADS.**  
Brill (J. G.) Co., Philadelphia, Pa.  
STEPHENSON (JOHN) COMPANY, Limited, 47 E. 27th st., New York. (Branch—Phenix Bldg., Chicago.)

**DRIVING MACHINERY.**  
HORACE A. KEEFER CO. (The), Kansas City, Mo.  
LANE & BODLEY CO. (The), 267-283 Water st., Cincinnati, Ohio.

Pease & Hunt, Baltimore, Md. (vide Grips).

**DUST GUARDS (For Oil Boxes).**  
VULCANIZED FIBRE CO., Wilmington, Delaware. (New York offices, 15 DeY st.)

**ELECTRIC RAILWAY CASTINGS.**  
Wm. Wharton, Jr., & Co. (Incorporated), 25th st. and Washington av., Philadelphia, Pa.

**ELECTRIC RAILWAY PATENTS.**  
OVERLAND CONDUCTOR ELECTRIC RAILWAY CO. (The), (Thomas B. Kerr, Sec'y.), Pittsburgh, Pa.

**ELECTRIC RAILWAYS (Equipment).**  
BENTLEY-KNIGHT ELECTRIC RAILWAY CO., 115 Broadway, New York. Constructors, (Rhode Island Locomotive Works, Providence, R. I.)

DAFT ELECTRIC LIGHT CO. (The), 115 Broadway, New York. (Factory at Jersey City, N. J.) (Sub. Co.—Electric Power Co., 115 Broadway, New York.)  
Safety Electric Power Co., 41 Wall st., New York.

Safety Electric Power Co., 41 Wall st., New York.  
Safety Electric Power Co., Boston; and Rhode Island Electric Power Co., Providence, R. I.)  
SAFETY ELECTRIC CONSTRUCTION CO. (Duct system), 115 Wall st., New York. (Factory at Greenville, N. J.)

SPECIAL ELECTRIC RAILWAY & MOTOR CO., 16 and 18 Broad st., New York. (Special work at New York factory, 510 W. 30th st. Standard work at the Edison Manufacturing Co., 44 W. N. Y.) (Branches—55 Oliver st., Boston; 20 Caron ledge st., New Orleans; 133 Jefferson av., Detroit; 185 Dearborn st., Chicago; 200 Broadway, St. Louis; 115 S. 4th st., Philadelphia; 117 Public sq., Cleveland, O.)

VANDEPOLE ELECTRIC MFG. CO., 15, 17, 19 and 21 Clinton st., Chicago. (Branch—45 Broadway, New York.)

**ELEVATED RAILWAYS.**  
Meigs Elevated Railway Construction Co., 235 Bridge East Cambridge, Mass.

Elley Railway Construction Co. (The), Bloomfield, N. J. (Branches—93 Milk st., Boston; 196 Greenwich st., New York.)



ENGINEERS' INSTRUMENTS (Survey).  
ALOE, E. S. & CO., 309 N. Fourth st., St. Louis, Mo.  
ENGRAVERS  
VANDEKROOK & CO., Chicago, Ill.

**FARE BOXES.**  
ADAMS & WESTLAKE CO. (The), 110 Ontario st., Chicago, 115 Broadway, New York.  
Beaman, T. L., Knoxville, Tenn.  
BARNHILL & WRIGHT CAR CO., 2300 Broadway, St. Louis, Mo.  
Dederick, Z. P., Sherman, Texas.  
Greedy, The E. S. & Co., 5 and 7 Day st., New York.  
Haines Bros., 55 Broadway, New York.  
HORACE A. KEEFER CO. (The), Kansas City, Mo.  
JOHNSON, TOM L., Indianapolis, Ind.  
Laclede Car Co., 4500 N. Second st., St. Louis, Mo.  
LEWIS & FOWLER MFG. CO. (The), 27 to 35 Walworth st., Brooklyn, N. Y.

MARTIN, RUFUS & CO., 13 Park Row, New York.  
MANSON, MILTON I., (agent for Slawson's boxes), 365 Avenue A, New York.  
PUGH & RUSSELL, Stewart Bldg., New York; Phenix Bldg., Chicago, Ill.  
STEPHENSON (JOHN) COMPANY, Lim., New York.  
WALLES MFG. CO., 76 and 78 E. Water st., Syracuse, New York.

WILLS & BAUGHRAN, 1804 Mission st., San Francisco, Cal.  
Whiting, T. J., 7A South Place, Finsbury, London.  
**FAIR COLLECTORS (Automobile).**  
Greedy, The E. S. & Co., 5 and 7 Day st., New York.  
Haines Bros., 55 Broadway, New York.  
Kaye (Joseph) & Sons, Leeds. (London office—93 High Holborn, W. C., London.)  
Laclede Car Co., 4500 N. Second st., St. Louis, Mo.  
LEWIS & FOWLER MFG. CO. (The), 27 to 35 Walworth st., Brooklyn, N. Y.

MARTIN, RUFUS & CO., 13 Park Row, New York.  
STEPHENSON (JOHN) COMPANY, Limited, 47 E. 27th st., New York. (Branch—Phenix Bldg., Chicago.)  
**FAIR REGISTERS.**  
Bell Punch Co. (The) Limited, 24 Tabernaacle st., Finsbury sq., E., London.  
Brill (J. G.) Co., Philadelphia.  
Greedy, The E. S. & Co., 5 and 7 Day st., New York.  
Haines Bros., 55 Broadway, New York.  
Kaye (Joseph) & Sons, Leeds. (London office—93 High Holborn, W. C., London.)  
Laclede Car Co., 4500 N. Second st., St. Louis, Mo.  
LEWIS & FOWLER MFG. CO. (The), 27 to 35 Walworth st., Brooklyn, N. Y.

Marshall Fairs Co., 13 Park Row, New York.  
MARTIN, RUFUS & CO., 13 Park Row, New York.  
Post & Company, Cincinnati, Ohio.  
PUGH & RUSSELL, Stewart Bldg., New York; Phenix Bldg., Chicago, Ill.  
RAILWAY REGISTER MFG. CO. (Jas. McCredie, President, 104 Beady, N. Y., Ed. Beady, manager, 1193 Broadway, New York; J. F. Cortney, general agent, 423 Walnut st., Philadelphia, Pa.) Standard Index & Register Co., 138 Fulton st., New York.  
STEPHENSON (JOHN) COMPANY, Limited, 47 E. 27th st., New York. (Branch—Phenix Bldg., Chicago.)

**FASTENINGS.**  
Cambria Iron Co., 218 S. 4th st., Philadelphia, (vide Axes).  
**FIELD CUTTERS.**  
BELLE CITY MFG. CO., Racine, Wis.  
Kraestner, Charles & Co., 303 S. Canal, Chicago.  
MARTIN, RUFUS & CO., 13 Park Row, New York.  
PUGH & RUSSELL, Stewart Bldg., New York; Phenix Bldg., Chicago, Ill.  
Rosa Mfg. Co., Springfield, O.  
**FIELD MILLS.**  
Foss Mfg. Co., The Springfield, O.  
Kraestner, Chas. & Co., 303 S. Canal, Chicago.  
MARTIN, RUFUS & CO., 13 Park Row, New York.  
Noye, The J. T., Mfg. Co., Buffalo, N. Y. (Branches at Chicago, Ill., and Minneapolis, Minn.)  
PUGH & RUSSELL, Stewart Bldg., New York; Phenix Bldg., Chicago, Ill.

**FLOOR PAINT.**  
CHICAGO WOOD FINISHING CO., 143 and 145 S. Clinton st., Chicago, Ill.  
**FOLDING MATS.**  
BEADLE, EDWARD, 1193 Broadway, New York  
Car Factory—Crosby, 5 and 7 Day st., New York.  
Warneck & Toller, 311 E. 22d st., New York. "Rolling Wood Mat."

**FROGS.**  
ANDREWS, FRANK H., 545 W. 33rd st., New York (vide Brakes).  
Ayres, Abraham, 502 to 518 W. 45th st., New York.  
BALTIMORE CAR WHEEL CO. (The), Baltimore, Md. (vide Car Wheels).  
Chester Steel Castings Co., 407 Library st., Philadelphia, Pa.  
Erick, Wm. E., 95 Liberty, New York.  
Dederick, Z. P., Sherman, Texas.  
FULTON FOUNDRY, Cleveland, O. (vide Axes).  
Greedy, The E. S. & Co., 5 and 7 Day st., New York.  
HORACE A. KEEFER CO. (The), Kansas City, Mo.  
Howard, Chiles & Co., Hamilton Bldg., Pittsburgh, Pa.  
JOHNSON, TOM L., Indianapolis, Ind. (The), Johnston, Pa. (vide Cable Vokes).  
Johnston Railroad Frog & Switch Co., 307 Walnut st., Philadelphia, Pa.  
LEWIS & FOWLER MFG. CO. (The), 27 to 35 Walworth st., Brooklyn, N. Y.  
Metals Street Railway Supply Co., Albany, N. Y. (vide Cable Vokes).  
Meyersburg, O. W. & Co., 204 N. 3d st., St. Louis, Mo. (Branch—Phenix Bldg., Chicago, Ill.)  
PENNSYLVANIA STEEL CO., Philadelphia (vide Axes).  
PUGH & RUSSELL, Stewart Bldg., New York; Phenix Bldg., Chicago, Ill.  
WAX FOUNDRY CO. (The), 23rd and Wood sts., Philadelphia, Pa.  
Wm. Wharton, Jr., & Co. (Incorporated), 25th st. and Washington ave., Philadelphia, Pa.  
Whiting Manufacturing Co., Cedar Rapids, Iowa.

**GLASS.**  
Mississippi Glass Co., Main and Angelica sts., St. Louis, Mo. (Agent—Gilbert S. King, 102 Chambers st., New York.)  
The Western Sand Blast Co., n.w. cor. Clinton and Jackson sts., Chicago, Ill.  
**GREASE.**  
Chicago Lubricant Mfg. Co., 51 Dearborn st., Chicago, Ill.  
Ohio Lubricating Oil, Buffalo, N. Y. (Agents—Francis & Emuls, Willis Barre, Pa.)  
MARTIN, RUFUS & CO., 13 Park Row, New York.

**GRINDERS (Car Wheel).**  
Greedy, The E. S. & Co., 5 and 7 Day st., New York.  
Post & Company, Cincinnati, Ohio.  
PUGH & RUSSELL, Stewart Bldg., New York; Phenix Bldg., Chicago, Ill.

**GRUPS (Cable).**  
ANDREWS, FRANK H., 545 W. 33rd st., New York (vide Brakes).  
BALTIMORE CAR WHEEL CO. (The), Baltimore, Md. (vide Car Wheels).  
Chester Steel Castings Co., 407 Library st., Philadelphia, Pa.  
Gould, John H. & Gould & Co., 305 to 311 S. 2d st. (Manufacture), n.w. cor. 9th and Market sts., and 37 E. 2d st., Philadelphia, Pa.  
JOHNSON, TOM L., Indianapolis, Ind.  
Laclede Car Co., 4500 N. Second st., St. Louis, Mo.  
LEWIS & FOWLER MFG. CO. (The), 27-283 Water st., Cincinnati, Ohio.  
Poole & Hunt, Baltimore, Md. (Works at Woodberry, Maryland.)  
Van Dusen & TIT, 102 and 104 E. 2d st., Cincinnati, O.  
Wm. Wharton, Jr., & Co. (Incorporated), 25th st. and Washington ave., Philadelphia, Pa.

**GROOMING MACHINES.**  
PUGH & RUSSELL, Stewart Bldg., New York; Phenix Bldg., Chicago, Ill.  
**GROOVY CURVES.**  
ANDREWS, FRANK H., 545 W. 33rd st., New York (vide Brakes).  
Craig, Wm. F., Liberty st., New York.  
FULTON FOUNDRY, Cleveland, Ohio (vide Axes).  
Haines Bros., 55 Broadway, New York.  
Howard, Chiles & Co., Hamilton Bldg., Pittsburgh, Pa.  
JOHNSON STEEL STREET RAIL CO. (The), Johnston, Pa. (vide Cable Vokes).  
LEWIS & FOWLER MFG. CO. (The), 27 to 35 Walworth st., Brooklyn, New York.  
Meyersburg, O. W. & Co., 204 N. 3d st., St. Louis, Mo.  
PENNSYLVANIA STEEL CO., Philadelphia (vide Axes).  
PUGH & RUSSELL, Stewart Bldg., New York; Phenix Bldg., Chicago, Ill.

STEEL RAIL CO. (The), 39th and 40th Sts., Philadelphia, Pa.  
SNEAD & BIBB, Louisville, Ky.  
Wm. Wharton, Jr., & Co. (Incorporated), 25th st. and Washington ave., Philadelphia, Pa.  
**HAMERS.**  
Pratt & Letchworth, Buffalo, N. Y.  
**HAMES COUPLERS.**  
DICKSON, C. H., Seely Northern Central Ry. Co., St. Louis, Mo.

**HARNESSES.**  
Brill (J. G.) Co., Philadelphia.  
Leffle (John) & Co., London (12 St. Mary Axe, E. C.).  
MARTIN, RUFUS & CO., 13 Park Row, New York.  
PUGH & RUSSELL, Stewart Bldg., New York; Phenix Bldg., Chicago, Ill.  
**HEAD-LIGHTS & LANTERNS.**  
ADAMS & WESTLAKE CO. (The), 110 Ontario st., Chicago, Ill.; 115 Broadway, New York.

**HORSE PAIDS.**  
McClain, E. C., Cincinnati.  
**HORSE-SHOE NAILS.**  
Champion Horse Nail Co., London, Wis.  
Howard, Chiles & Co., Hamilton Bldg., Pittsburgh, Pa.  
Kimball, R. D., Michigan ave. and Lake st., Chicago, Ill.  
Northwestern Horse Nail Co., 222 S. Clinton st., Chicago.  
PUGH & RUSSELL, Stewart Bldg., New York; Phenix Bldg., Chicago, Ill.  
Putnam Shoe Works, Neponset P. O., Boston, Mass. The United Horse Shoe and Nail Co., Limited, 115 Cannon st., E. C., London.

**HORSE-SHOE VISES.**  
BUTLER, P. O., 360 Dorchester av., Boston, Mass. (vide Tool Cases).  
**HYDRAULIC JACKS.**  
Brill (J. G.) Co., Philadelphia.  
Greedy, The E. S. & Co., 5 and 7 Day st., New York.  
Howard, Chiles & Co., Hamilton Bldg., Pittsburgh, Pa.  
Post & Company, Cincinnati, Ohio.  
PUGH & RUSSELL, Stewart Bldg., New York; Phenix Bldg., Chicago, Ill.  
Watson & Stillman, 210 E. 43rd st., New York.

**JOINTS.**  
WAY FOUNDRY CO. (The), 23rd and Wood sts., Philadelphia, Pa.  
**JOURNAL BOXES.**  
ANDREWS, FRANK H., 545 W. 33rd st., New York (vide Brakes).  
BALTIMORE CAR WHEEL CO. (The), Baltimore, Md. (vide Car Wheels).  
BEMIS CAR BOX CO., Springfield, Mass.  
BALTIMORE CAR WHEEL CO. (The), Baltimore, Md. (vide Car Wheels).  
BROOKLYN RAILWAY SUPPLY CO. (The), 44 Walworth st., Brooklyn, New York.  
Brooklyn Railway Supply Co., 2306 Broadway, St. Louis, Mo.  
Chester Steel Castings Co., 407 Library st., Philadelphia, Pa.  
Dederick, Z. P., Sherman, Texas.  
FULTON FOUNDRY, Cleveland, Ohio (vide Axes).  
Greedy, The E. S. & Co., 5 and 7 Day st., New York.  
Howard, Chiles & Co., Hamilton Bldg., Pittsburgh, Pa.  
Keystone Melting Co. (The), Limited, 33rd St. Pittsburgh, Pa.  
Laclede Car Co., 4500 N. Second st., St. Louis, Mo.  
LEWIS & FOWLER MFG. CO. (The), 27 to 35 Walworth st., Brooklyn, N. Y.  
MARTIN, RUFUS & CO., 13 Park Row, New York.  
Meyersburg, O. W. & Co., 204 N. 3d st., St. Louis, Mo. (Branch—Phenix Bldg., Chicago, Ill.)  
Miller, Chas. J., 210 E. 43rd st., New York.  
Post & Company, Cincinnati, Ohio.  
PUGH & RUSSELL, Stewart Bldg., New York; Phenix Bldg., Chicago, Ill.

SNEAD & BIBB, Louisville, Ky.  
STEPHENSON (JOHN) COMPANY, Limited, 47 E. 27th st., New York. (Branch—Phenix Bldg., Chicago.)  
STREET RAILWAY SUPPLY CO., Cleveland, Ohio.  
VAN DUSEN & TIT, 102 and 104 E. 2d st., Cincinnati, Ohio.  
Wm. Wharton, Jr., & Co. (Incorporated), 25th st. and Washington ave., Philadelphia, Pa.  
Whiting Manufacturing Co., Cedar Rapids, Iowa.  
WHITNEY, A., & SONS, Philadelphia, Pa.  
**K.N.E.S.**  
ANDREWS, FRANK H., 545 W. 33rd st., New York (vide Brakes).  
WAY FOUNDRY CO. (The), 23rd and Wood sts., Philadelphia, Pa.

**LAMP HOUSE LATHING.**  
STEPHENSON, JOHN, Limited, 47 E. 27th st., New York. (Branch—Phenix Bldg., Chicago.)  
**LAMP TRIMMINGS.**  
ADAMS & WESTLAKE CO. (The), 110 Ontario st., Chicago, Ill.; 115 Broadway, New York.  
Post & Company, Cincinnati, Ohio.

**MATTINGS.**  
Ber Upholster, Mat., Etc.  
**MOTORS.**  
Brill (J. G.) Co., Philadelphia, Pa.  
Haines Bros., 55 Broadway, New York.  
PUGH & RUSSELL, Stewart Bldg., New York; Phenix Bldg., Chicago, Ill.  
Standard Pileas Engine Co., 12 Chartres st., New Orleans, La.  
Pole Star Motor System, 310 Chestnut st., Philadelphia, Pa.  
**MOTORS (Electric).**  
BENNETT, R. KNIGHT, ELECTRIC RAILWAY CO., 115 Broadway, New York.  
Cleveland Electric Motor Co., First Nat'l Bank Bldg., Cleveland, Ohio.  
DAET ELECTRIC LIGHT CO. (The), 115 Broadway, New York.  
Greedy, The E. S. & Co., 5 and 7 Day st., New York.  
Haines Bros., 55 Broadway, New York.  
Henry Electric Railway Co., Kansas City, Mo.  
Hick, Kerr & Co., 101 Leadenhall st., E. C., London. (vide Car Bulbers).  
Julien Electric Co., 120 Broadway, New York.  
Kerr, N. S., 40 Nevada Block, San Francisco, Cal.  
MARTIN, RUFUS & CO., 13 Park Row, New York.  
PUGH & RUSSELL, Stewart Bldg., New York; Phenix Bldg., Chicago, Ill.

SARLEY ELECTRIC CONSTRUCTION CO. (DAET SYSTEM), 41 Wall st., New York.  
SPRINGUE ELECTRIC RAILWAY & MOTOR CO., 16 E. 18th Street, New York (vide Electric Railways).  
VAN DEPOLE ELECTRIC MFG. CO., 15 to 21 Clinton st., Chicago, Ill. (Branch—45 Broadway, N. Y. West J., 851 Plover ave., Jersey City Heights, N. J.)  
**MOTORS (Gas).**  
The Connelly Motor Co., 177 Broadway, New York.

**MOTORS (Steam).**  
BALDWIN LOCOMOTIVE WORKS, Philadelphia.  
Black, Hawthorn & Co., Gateshead-on-Tyne, England.  
Buck, Kerr & Co., 101 Leadenhall st., E. C., London. (vide Car Bulbers).  
Fairton Engine & Car Works, Limited, Longborough, Eng. (London Office—41 Colmore Row, E. C.).  
Greedy, The E. S. & Co., 5 and 7 Day st., New York.  
Green, Thos., & Son, Limited, Southfield Road Works, Leeds, & Surrey Works, Blackfriars Road, S. E., London.  
Haines Bros., 55 Broadway, New York.  
Henschel & Sohn, Cassel, Germany.  
New York Safety Steam Power Co., 64 S. Canal st., Chicago.  
PORTELL, H. K. & Co., Pittsburgh, Pa.  
PUGH & RUSSELL, Stewart Bldg., New York; Phenix Bldg., Chicago, Ill.

**OFFICE FURNITURE, PAPER E. C.**  
ALOE, E. S. & CO., 309 S. 4th st., St. Louis, Mo.  
Bale & Kilburn Mfg. Co. (The), 48 and 50 N. 6th st., Philadelphia, Pa.  
The Globe Co., Cincinnati, Ohio.  
**OIL AND DUST TIGHT CARGEARING.**  
BALTIMORE CAR WHEEL CO. (The), Baltimore, Md. (vide Car Wheels).

**OILS.**  
Duncan, Watson & Co., Dashedown House, New Broad Street, London.  
Vacuum Oil Co., Rochester, N. Y. (Branches—208 Home Insurance Building, Chicago; 10th and Spruce sts., St. Louis, Mo.; 90 Louis, Mo.; 90 New York, N. Y. Gas, Bldg., Cincinnati; 45 Purchase st., Boston; 150 Park av., Pittsburgh; 305 Walnut st., Philadelphia; 2165 Wash. av. St., Minneapolis; 17 Sunb's Whl Baltimore, Md.; 138 St. James st., Montreal, and 96 King st., West, Toronto, Canada.)  
**OMNIBUS HARDWARE.**  
ADAMS & WESTLAKE CO. (The), 110 Ontario st., Chicago, 115 Broadway, New York.

**PAINTS.**  
Brill (J. G.) Co., Philadelphia.  
BARNHILL & WRIGHT CAR CO. 2300 Broadway, St. Louis, Mo.  
CHICAGO WOOD FINISHING CO., 143 and 145 S. Clinton st., Chicago, Ill.  
COFFIN, DEVOE & CO., 176 Randolph st., Chicago, Ill.  
IRON CLAD PAINT CO., 3 Case Bldg., Cleveland, O.  
Laclede Car Co., 4500 N. Second st., St. Louis, Mo.  
Lowes Metallic Paint Co., Chattanooga, Tenn.  
MARTIN, RUFUS & CO., 13 Park Row, New York.  
Peabody, Hy. W. & Co., Mason Building Boston. (Branches—81 New st., New York; Leadenhall House, Leadenhall st., E. C., London, Eng.)  
Post & Company, Cincinnati, Ohio.  
PUGH & RUSSELL, Stewart Bldg., New York; Phenix Bldg., Chicago, Ill.  
Sherwin-Williams Co. (The), Cleveland, Ohio (vide Colors).  
Valentine & Co., 245 Broadway, New York. (Branches—48 Lake st., Chicago; 155 30th st., Boston; 21 Rue de Lappe, Paris.)

**PANELS.**  
Brill (J. G.) Co., Philadelphia.  
BROWNELL & WRIGHT CAR CO. 2300 Broadway, St. Louis, Mo.  
KUHLMANN CAR CO., 490 St. Clair st., Cleveland, O.  
Laclede Car Co., 4500 N. Second st., St. Louis, Mo.  
MARTIN, RUFUS & CO., 13 Park Row, New York.  
PUGH & RUSSELL, Stewart Bldg., New York; Phenix Bldg., Chicago, Ill.  
STEPHENSON (JOHN) COMPANY, Limited, 47 E. 27th st., New York. (Branch—Phenix Bldg., Chicago.)

**PEDESTALS.**  
ANDREWS, FRANK H., 545 W. 33rd st., New York (vide Brakes).  
Ayres, Abraham, 502 to 518 W. 45th st., New York.  
BALTIMORE CAR WHEEL CO. (The), Baltimore, Md. (vide Car Wheels).  
BEMIS CAR BOX CO., Springfield, Mass.  
Brill (J. G.) Co., Philadelphia.  
BROWNELL & WRIGHT CAR CO. 2300 Broadway, St. Louis, Mo.  
Dederick, Z. P., Sherman, Texas.  
Ohio Co., Cleveland, Ohio.  
FULTON FOUNDRY, Cleveland, Ohio (vide Axes).  
Laclede Car Co., 4500 N. Second st., St. Louis, Mo.  
LEWIS & FOWLER MFG. CO. (The), 27 to 35 Walworth st., Brooklyn, N. Y.  
PUGH & RUSSELL, Stewart Bldg., New York; Phenix Bldg., Chicago, Ill.

**PLATE GLASS.**  
Mississippi Glass Co., Main and Angelica sts., St. Louis, Mo. (Agent—Gilbert S. King, 102 Chambers st., New York.)  
The Western Sand Blast Co., n.w. cor. Clinton and Jackson sts., Chicago, Ill.



SNEAD & BIBB, Louisville, Ky.  
STEPHENSON (JOHN) COMPANY, Limited, 47 E. 27th st., New York, (Br.)—Phenix Bldg., Chicago.  
STREET RAILWAY SUPPLY CO., Cleveland, Ohio.  
Wm. Wharton, Jr., & Co. (Incorporated), 25th st. and Washington ave., Philadelphia, Pa.  
WHITNEY A., & SONS, Philadelphia, Pa.

**PHOSPHOR BRONZE, Etc.**  
Tubal Smelting Works, 760 So. Broad st., Philadelphia.  
**PHOSPHOR BRONZE CABLE GRIPS.**  
Van Duzen & TIL, 102 and 104 E. Second st., Cincinnati, Ohio.

**POISHENS.**  
CHICAGO WOOD FINISHING CO., 143 and 145 S. Clinton st., Chicago, Ill.  
CLINE MFG. CO., 277 and 278 S. Canal st., Chicago.  
Gould, J. H., & Co., Philadelphia (vide Grips).  
MARTIN, RUFUS, & Co., 13 Park Row, New York.  
PUGH & RUSSELL, Stewart Bldg., New York; Phenix Bldg., Chicago, Ill.

**POLISHING MACHINERY.**  
Watson & Stillman, 210 E. 43rd st., New York.

**PRESSES (Car Wheel).**  
ANDREWS, FRANK H., 545 W. 33rd st., New York (vide Brakes).  
Brill (J. G.), Philadelphia.  
Greely, The E. S., & Co., 5 and 7 Dey st., New York.  
PAT. H. & RUSSELL, Stewart Bldg., New York; Phenix Bldg., Chicago, Ill.  
Watson & Stillman, 210 E. 43rd st., New York.

**PULLEYS AND SHEAVES.**  
LANE & BODLEY CO. (The), 267-283 Water st., Cincinnati, Ohio.  
Pooie & Haut, Baltimore, Md. (vide Grips).

**PUNCHES AND SHEARS.**  
Watson & Stillman, 210 E. 43rd st., New York.  
RAILWAY REGISTER & MFG. CO., 1193 Broadway, New York (vide Registering Punches).

**PURCHASING AGENTS.**  
Peabody, Henry W., & Co., Boston (vide Paints).

**RAILS (Curved).**  
ANDREWS, FRANK H., 545 W. 33rd st., New York (vide Brakes).  
Ayres, Abraham, 502 to 518 W. 45th st., New York.  
Craig, Wm. F., 95 Liberty st., New York.  
FULTON FOUNDRY, Cleveland, O. (vide Axles).  
Haines Bros., 55 Broadway, New York.  
HORACE A. KEEFER CO. (The), Kansas City, Mo.  
Howard, Childs & Co., Hamilton bldg., Pittsburgh, Pa.  
JOHNSON STEEL STREET RAIL CO. (The), Johnston, Pa. (vide Cable Yokes).  
LEWIS & FOWLER MFG. CO. (The), 27 to 35 Walworth st., Brooklyn, N. Y.  
LONGSTREET, D. F., Providence, R. I. (Agents)—Wm. Wharton, Jr., & Co. (Incorporated), Phila. (delphia).  
Metallic Street Railway Supply Co., Albany, N. Y. (vide Cable Yokes).  
Meyenburg, O. W., & Co., 204 N. 3d st., St. Louis, Mo. (Branch)—Phenix Bldg., Chicago, Ill.)  
Pennsylvania Steel Co., Philadelphia (vide Axles).  
PUGH & RUSSELL, Stewart Bldg., New York; Phenix Bldg., Chicago, Ill.)  
St. Thomas Car Wheel Co., St. Thomas, Ont., Canada.  
STREET RAILWAY SUPPLY CO., Cleveland, Ohio.  
Wm. Wharton, Jr., & Co. (Incorporated), 25th st. and Washington ave., Philadelphia, Pa.  
Whiting Manufacturing Co., Cedar Rapids, Iowa.

**RAILS (Steel).**  
ANDREWS, FRANK H., 545 W. 33rd st., New York (vide Brakes).  
Ayres, Abraham, 502 and 518 W. 45th st., New York.  
Cambria Iron Co., 218 S. 4th st., Philadelphia, (vide Axles).  
Carnegie, Phlips & Co., Limited, 48 Fifth ave., Pittsburgh, Pa.  
Craig, Wm. F., 95 Liberty st., New York.  
Edgerton, Geo. M., 204 N. Third st., St. Louis, Mo.  
FULTON FOUNDRY, Cleveland, O. (vide Axles).  
Haines Bros., 55 Broadway, New York.  
HORACE A. KEEFER CO. (The), Kansas City, Mo.  
Howard, Childs & Co., Hamilton bldg., Pittsburgh, Pa.  
JOHNSON STEEL STREET RAIL CO. (The), Johnston, Pa. (Branches)—Gotton Exchange bldg., New Orleans; Phoenix bldg., Chicago; Bank of Commerce bldg., 6 Oliver st., Boston.  
Stewart Bldg., New York; Johnson bldg., Cincinnati; 253 W. Main st., Louisville, Ky.)  
LONGSTREET, D. F., Providence, R. I. (Agents)—Wm. Wharton, Jr., & Co., Philadelphia, Pa.)  
Metallic Street Railway Supply Co., Albany, N. Y. (vide Cable Yokes).  
Meyenburg, O. W., & Co., 204 N. 3d st., St. Louis, Mo. (Branch)—Phenix Bldg., Chicago, Ill.)  
North Chicago Rolling Mill Co., 17 Metropolitan block, Chicago. (Branch—New Insurance bldg., Milwaukee).  
Pennsylvania Steel Co., Philadelphia (vide Axles).  
Post & Company, Cincinnati, Ohio.  
PUGH & RUSSELL, Stewart Bldg., New York; Phenix Bldg., Chicago, Ill.)  
Springfield Iron Co. (The), Springfield, Ill. (Branch—15 Dearborn st., Chicago).  
STREET RAILWAY SUPPLY CO., Cleveland, Ohio.  
Wm. Wharton, Jr., & Co. (Incorporated), 25th st. and Washington ave., Philadelphia, Pa.  
Worcester Steel Co., Worcester, Mass.

**RAILS (Flat and T).**  
HATHAWAY & ROBINSON, 14 Case Bldg., Cleveland, O. Tudor Iron Works, 509 N. 3d st., St. Louis, Mo.

**RAILWAYS (Cable) BUILDERS.**  
ANDREWS, FRANK H., 545 W. 33rd st., New York (vide Brakes).  
BAKER, W. S. GRAFF, care Brown, Shipley & Co., London (vide Car Starters).  
Haines Bros., 55 Broadway, Philadelphia. (vide Grips).  
Haines Bros., 55 Broadway, New York.  
Hinkley, F. E., & Co., Room 606 First National Bank Bldg., Chicago, Ill.  
Metallic Street Railway Supply Co., Albany, N. Y. (vide Cable Yokes).  
Miller, D. J., 234 Broadway, New York.  
National Cable Railway Co., 140 Nassau st., New York.  
Patent Cable Trolley Carriage Co., Limited, Victoria Mansions, Westminster, S. W., London.  
Wm. Wharton, Jr., & Co. (Incorporated), 25th st. and Washington ave., Philadelphia, Pa.  
Wright Construction Co., Phenix Bldg., Chicago.  
Wright, Meyenburg & Co., St. Louis, Mo.

**RAILWAYS (Electric) BUILDERS.**  
BENTLEY-KNEPP ELECTRIC RAILWAY CO., 115 Broadway, New York.  
Chadbourne & Hastings (Agents for Sprague motors), 119 S. 4th st., Philadelphia.

Cleveland Electric Motor Co. (vide Contractors and Builders).  
DAVEY ELECTRIC LIGHT CO. (The), 115 Broadway, New York.  
Haines Bros., 55 Broadway, New York.  
Haines, F. W., 2 Nassau st., room 17, New York.  
Henry Electric Railway Co. (The), Kansas City, Mo.  
Julien Electric Co., 120 Broadway, New York.  
Ketchum Street Railway Supply Co., Albany, N. Y. (vide Cable Yokes).  
SARAGUE ELECTRIC CONSTRUCTION CO. (DAFT SAFETY SYSTEM), 41 Wall st., New York.  
SPRING ELECTRIC RAILWAY MOTOR CO., 16 and 17 Front st., New York (vide Electric Railways).  
U. S. Electric Co., Denver, Col.  
VAN DEPOKLE ELECTRIC MANUFACTURING CO., 12 to 21 E. Clinton st., Chicago; 35 Broad, N. Y.  
Wm. Wharton, Jr., & Co. (Incorporated), 25th st. and Washington ave., Philadelphia, Pa.

**RAILWAYS (Horse) BUILDERS.**  
BAKER, W. S. GRAFF, care Brown, Shipley & Co., London (vide Car Starters).  
Craig, Wm. F., 95 Liberty st., New York.  
Haines Bros., 55 Broadway, New York.  
Haines, F. W., 2 Nassau st., room 17, New York.  
HATHAWAY & ROBINSON, 14 Case Bldg., Cleveland, O.  
JOHNSTON STEEL STREET RAIL CO. (The), Johnston, Pa. (vide Rails, Steel).  
LEWIS & FOWLER MFG. CO. (The), 27 to 35 Walworth st., Brooklyn, N. Y.  
MARTIN, RUFUS, & Co., 13 Park Row, New York.  
Metallic St. Ry. Supply Co., Albany, N. Y. (vide Cable Yokes).  
Wm. Wharton, Jr., & Co. (Incorporated), 25th st. and Washington ave., Philadelphia, Pa.  
Wright Construction Co., Phenix Bldg., Chicago.

**RAILWAYS (Steam) BUILDERS.**  
Haines Bros., 55 Broadway, N. Y.  
Harris, T. Wm., & Co., 2 Nassau st., room 17, New York.  
Metallic St. Ry. Supply Co., Albany, N. Y. (vide Cable Yokes).  
Wm. Wharton, Jr., & Co. (Incorporated), 25th st. and Washington ave., Philadelphia, Pa.

**REGISTERING PUNCHES (Alarm).**  
RAILWAY REGISTER MFG. CO., 1193 Broadway, New York (vide Fare Registers).

**ROAD CEMENTS.**  
Empire Webbs Co., 126-204 Market st., Chicago, Ill.  
McCammon, L. C., Cincinnati, O.  
Peabody, Henry W., & Co., Boston (vide Paints).

**ROUGH STUFF.**  
CHICAGO WOOD FINISHING CO., 143 and 145 S. Clinton st., Chicago, Ill.

**RUBBER TREADS (For Car Steps).**  
MARLIN, RUFUS, & Co., 13 Park Row, New York.  
Rubber-Step Mfg. Co., 49 Havenhill st., Boston, Mass.

**RUNNING GEAR (Super Spring).**  
SEBASTIAN, JOHN A. M., 47 E. 27th st., New York. (Branch)—Phenix Bldg., Chicago.)

**SAFETY PULL IRONS.**  
Brill (J. G.) Co., Philadelphia.

**SAND BOXES.**  
Brill (J. G.) Co., Philadelphia.

**CAR TRACK FRICTION AFFLIANCE CO. (The),** 19 Tremont bldg., Boston, Mass. (W. T. Butler, general manager).

Jordan Mills Mfg. Co. (The), 32 Nassau st., New York.  
Laclede Car Co., 450 N. Second st., St. Louis, Mo.  
LEWIS & FOWLER MFG. CO. (The), 27 to 35 Walworth st., Brooklyn, N. Y.

PUGH & RUSSELL, Stewart Bldg., New York; Phenix Bldg., Chicago, Ill.)

**SEATS AND SEAT SPRINGS.**  
Brill (J. G.) Co., Philadelphia.

BROWNELL & WIGHT CAR CO., 2300 Broadway, St. Louis, Mo.

Dayton Mfg. Co. (The), Dayton, Ohio.  
Laclede Car Co., 450 N. Second st., St. Louis, Mo.  
Hale & Kilburn Mfg. Co. (The), 48 and 50 N. 6th st., Philadelphia.

**HARTFORD WOVEN WIRE MATTRESS CO. (The),** F. Q. Box 363, Hartford, Conn.

Laclede Car Co., 450 N. Second st., St. Louis, Mo.  
LAWRENCE, J. W., 13 Park Row, New York.  
Post & Company, Cincinnati, Ohio.

PUGH & RUSSELL, Stewart Bldg., New York; Phenix Bldg., Chicago, Ill.)

**HANGING HANGERS AND PULLEYS.**  
LANE & BODLEY CO. (The), 267-283 Water st., Cincinnati, Ohio.

**SIGNAL LIGHTS.**  
ADAMS & WESTLAKE CO. (The), 110 Ontario st., Chicago, Ill.; 115 Broadway, New York.

Brill (J. G.) Co., Philadelphia.

BROWNELL & WIGHT CAR CO., 2300 Broadway, St. Louis, Mo.  
Greely, The E. S., & Co., 5 and 7 Dey st., New York.  
Laclede Car Co., 450 N. Second st., St. Louis, Mo.  
LEWIS & FOWLER MFG. CO. (The), 27 to 35 Walworth st., Brooklyn, N. Y.  
MARTIN, RUFUS, & Co., 13 Park Row, New York.  
Post & Company, Cincinnati, Ohio.

PUGH & RUSSELL, Stewart Bldg., New York; Phenix Bldg., Chicago, Ill.)

PUGH & RUSSELL, Stewart Bldg., New York; Phenix Bldg., Chicago, Ill.)  
Tudor Iron Works, 509 N. 3rd st., St. Louis, Mo.  
Wm. Wharton, Jr., & Co. (Incorporated), 25th st. and Washington ave., Philadelphia, Pa.

**SPLICERS FOR JOINING WIRE CABLES.**  
HAZARD MANUFACTURING CO. (The), Wilkes-Barre, Pa. (vide Cables).

**SPRINGS (STEEL).**  
Cambria Iron Co., 218 S. 4th st., Philadelphia, (vide Axles).

**STAINS.**  
CHICAGO WOOD FINISHING CO., 143 and 145 S. Clinton st., Chicago, Ill.

**STATIONARY ENGINE BUILDERS.**  
Ails, Edw. P., & Co., Milwaukee, Wis.  
Buck, George, & Co. (Sales Agents)—W. L. Shupp, 301 Telephone Building, 18 Cortland st., New York; John F. Fife, 30 Oliver st., Boston, Mass.; W. Robinson, car, Clinton and Jackson sts., Chicago, Ill.; Robinson & Corey st. Paul, Minn.; G. S. Wormer & Son, 705 Market st., St. Louis).

Derick, Z. P., Sherman, Texas.  
Fishkill Lumbering Machine Co., Fishkill-on-the-Hudson.  
Harris, Wm. A., Providence, R. I.  
HOVENS, OWENS & RENTSCHLER CO. (The), Hamilton, O.  
HORACE A. KEEFER CO. (The), Kansas City, Mo.  
Low Super, Chas., & Co., 303 S. Canal st., Chicago.  
LANE & BODLEY CO. (The), 267-283 Water st., Cincinnati, Ohio.  
New York Safety Steam Power Co., 64 S. Canal st., Chicago.  
Noy, The J. T., Manufacturing Co., Buffalo, N. Y. (Branches at Chicago, Ill., and Minneapolis, Minn.)  
Providence Steam Engine Co., Providence, R. I.  
Smith, Beers & Egan, St. Louis, Mo.  
Tod, Wm. & Co., Youngstown, Ohio.  
Whiting Manufacturing Co., Cedar Rapids, Iowa.

**STEAM BOILERS.**  
Heine Safety Boiler Co., 102 North Main st., St. Louis.  
Hess, Geo. W., 182 Madison st., Chicago.  
HOVENS, OWENS & RENTSCHLER CO. (The), Hamilton, O.

**STORAGE BATTERIES (for Lights, &c.)**  
Brush Electric Co. (The), Cleveland, O.  
Electrical Accumulator Co. (The), 44 Broadway, New York.  
Julien Electric Co., 120 Broadway, New York.

**SUPPLIES (General).**  
ANDREWS, FRANK H., 545 W. 33rd st., New York (vide Brakes).  
Brill (J. G.) Co., Philadelphia.

BROOKLYN RAILWAY SUPPLY CO. (The), 44 Walworth st., Brooklyn, N. Y.

BROWNELL & WIGHT CAR CO., 2300 Broadway, St. Louis, Mo.

Brook Street Castings Co., 407 Library st., Philadelphia.  
Child, O. W., & Co., 150 Broadway, New York.  
Craig, Wm. F., 95 Liberty st., New York.

Derick, Z. P., Sherman, Texas.  
Dwight, E. P., 407 Library st., Philadelphia.  
Fogge, Orlo A., Cleveland, O.

Greely, The E. S., & Co., 5 and 7 Dey st., New York.  
Haines Bros., 55 Broadway, New York.

HARTFORD WOVEN WIRE MATTRESS CO. (The), F. Q. Box 363, Hartford, Conn.

HATHAWAY & ROBINSON, 14 Case Bldg., Cleveland, O.  
Howard, Childs & Co., Hamilton bldg., Pittsburgh, Pa.  
Hulse, F. W., & Co., 107 Liberty st., New York.

JOHNSON STEEL STREET RAIL CO. (The), Johnston, Pa. (vide Rails, Steel).  
Kingsley & Robinson ave. and Lake st., Chicago, Ill.

LEWIS & FOWLER MFG. CO. (The), 27 to 35 Walworth st., Brooklyn, N. Y.

MARTIN, RUFUS, & Co., 13 Park Row, New York.  
Metallic Street Railway Supply Co. (The), Albany, N. Y.  
Phoenix Steel, Iron, Broom & Brush Co., 199 E. Randolph st., Chicago.

Post & Company, Cincinnati, Ohio.  
PUGH & RUSSELL, Stewart Bldg., New York; Phenix Bldg., Chicago, Ill.)  
Saxton, J. C., 52 Broadway, New York.

SETH J. JOSEPH, 102 to 518 W. 45th st., New York.  
STEPHENSON (JOHN) COMPANY, Limited, 47 E. 27th st., New York. (Branch)—Phenix Bldg., Chicago.)  
STREET RAILWAY SUPPLY CO., Cleveland, Ohio.  
Wm. Wharton, Jr., & Co. (Incorporated), 25th st. and Washington ave., Philadelphia, Pa.  
White, Edward, 107 E. 27th st., New York.

**SWEETING MACHINES (Dirt or Street).**  
BROOKLYN RAILWAY SUPPLY CO. (The), 44 Walworth st., Brooklyn, N. Y.

**SWICH CASTINGS.**  
HATHAWAY & ROBINSON, 14 Case Bldg., Cleveland, O.

**SWICH ROPES.**  
ROBBINGS' SONS CO., JOHN A., 117 and 119 Livingston st., New York.

**SWITCHES.**  
ANDREWS, FRANK H., 545 W. 33rd st., New York (vide Brakes).  
Ayres, Abraham, 502 to 518 W. 45th st., New York.

BALTIMORE CAR WHEEL CO. (The), Baltimore, Md. (vide Car Wheels).  
Craig, Wm. F., 95 Liberty st., New York.  
Derick, Z. P., Sherman, Texas.  
FULTON FOUNDRY, Cleveland, O. (vide Axles).  
Greely, The E. S., & Co., 5 and 7 Dey st., New York.

Haines Bros., 55 Broadway, New York.  
Howard, Childs & Co., Hamilton Building, Pittsburgh.  
JOHNSON STEEL STREET RAIL CO. (The), Johnston, Pa. (vide Rails, Steel).  
Johnston Railroad Frog & Switch Co., 307 Walnut st., Philadelphia.

LEWIS & FOWLER MFG. CO. (The), 27 to 35 Walworth st., Brooklyn, N. Y.

PUGH & RUSSELL, Stewart Bldg., New York; Phenix Bldg., Chicago, Ill.)  
SNEAD & BIBB, Louisville, Ky.  
WAY FOUNDRY CO. (The), 33rd and Wood sts., Philadelphia, Pa.  
Wm. Wharton, Jr., & Co. (Incorporated), 25th st. and Washington ave., Philadelphia, Pa.

WHITE, M. M., & Co., 531 W. 33rd st., New York.  
Whitney Mfg. Co., Cedar Rapids, Iowa.

**SWITCHES (Automatic).**  
ANDREWS, FRANK H., 545 W. 33rd st., New York (vide Brakes).  
Ayres, Abraham, 502 to 518 W. 45th st., New York.  
Craig, Wm. F., 95 Liberty st., New York.  
FULTON FOUNDRY, Cleveland, O. (vide Axles).  
Greely, The E. S., & Co., 5 and 7 Dey st., New York.



**HATHAWAY & ROBINSON**, Room 14 Case Building, Cleveland, Ohio.  
**HOBBS & K. Co.**, (The), Kansas City, Mo.  
**JOHNSON STEEL STEEL RAIL CO.** (The), Johnstown, Pa. (vide Rails, Steel).  
**LEWIS & FOWLER MFG. CO.** (The), 27 to 35 Walworth st., Brooklyn, N. Y.  
**METALLIC ST. IRON SUPPLY CO.**, Albany, N. Y. (vide Cable Tables).  
**PUGH & RUSSELL**, Stewart Bldg., New York; Phenix Bldg., Chicago, Ill.  
**Wm. Wharton, Jr. & Co.** (Incorporated), 25th st. and Washington ave., Philadelphia, Pa.  
**WHITE, M. M. & Co.**, 531 W. 33rd st., New York.

**TENSION CALCULATIONS.**  
**LAW & BOYD**, 214 Water st., Cincinnati, O.  
**POOLE & HUNT**, Baltimore, Md. (vide Grips).

**TICKETS.**  
**Bell Parich Co.** (The), Limited, 21 Tabernacle st., Finsbury, London, E. C., London.  
**Forster, O. A., Mercers' Row**, Northampton, England.  
**Jones (J. M. W.) Stationery & Printing Co.**, Dearborn Ave., Chicago, Ill.  
**Whiting T. J.**, 7A South Place, Finsbury, E. C., London.

**TIE PLATES.**  
**JOHNSON STEEL STREET RAIL CO.** (The), Johnstown, Pa. (vide Rails, Steel).

**TIE ROBS.**  
**JOHNSON STEEL STREET RAIL CO.** (The), Johnstown, Pa. (vide Rails, Steel).

**TOE CALKS.**  
**BURKE, P. F.**, 360 Dorchester ave., Boston, Mass. (Agents—Kelly, Mann & Co., Chicago, Ill.; Livingston Horse Nail Co., New York, N. Y.)  
**Cambrla Iron Co.**, 218 S. 4th st., Philadelphia (vide Axles).  
**Howard, Childs & Co.**, Hamilton Building, Pittsburgh, Pa.  
**PUGH & RUSSELL**, Stewart Bldg., New York; Phenix Bldg., Chicago, Ill.

**TOOLS (Track and St-ble).**  
**BERG & YN RAILWAY SUPPLY CO.** (The), 44 Walworth st., Brooklyn, N. Y.  
**Craig, Wm. P.**, 95 Liberty st., New York.  
**Grealey, The E. S. & Co.**, 5 and 7 Dey st., New York.  
**Haines Bros.**, 55 Broadway, New York.  
**Howard, Childs & Co.**, Hamilton Building, Pittsburgh, Pa.  
**LEWIS & FOWLER MFG. CO.** (The), 27 to 35 Walworth st., Brooklyn, N. Y.  
**MARTIN, RUFUS, & Co.**, 13 Park Row, New York.  
**Post & Company**, Cincinnati, Ohio.  
**PUGH & RUSSELL**, Stewart Bldg., New York; Phenix Bldg., Chicago, Ill.  
**STREET RAILWAY SUPPLY CO.**, Cleveland, Ohio.  
**Wm. Wharton, Jr. & Co.** (Incorporated), 25th st. and Washington ave., Philadelphia, Pa.

**TRACK CASTINGS.**  
**ANDREWS, FRANK H.**, 545 W. 33rd st., New York (vide Brakes).  
**Ayres, Abraham**, 502 to 518 W. 45th st., New York.  
**BALTIMORE CAR WHEEL CO.** (The), Baltimore, Md. (vide Car Wheels).  
**BOWLER & Co.**, Cleveland, O.  
**Chester Steel Castings Co.**, 407 Library st., Philadelphia.  
**Craig, Wm. P.**, 95 Liberty st., New York.  
**Deulerer, Z. F.**, Sherman, Texas.  
**Foote, Orlo A.**, Cleveland, O.  
**FULTON FOUNDRY**, Cleveland, Ohio (vide Axles).  
**Haines Bros.**, 55 Broadway, New York.  
**HORACE A. KEEFER CO.** (The), Kansas City, Mo.  
**Howard, Childs & Co.**, Hamilton Building, Pittsburgh, Pa.  
**JOHNSON STEEL STREET RAIL CO.** (The), Johnstown, Pa. (vide Rails, Steel).  
**LEWIS & FOWLER MFG. CO.** (The), 27 Walworth st., Brooklyn, N. Y.  
**Metallie Street Railway Supply Co.**, Albany, N. Y. (vide Cable Tables).  
**Meyensburg, O. W. & Co.**, 204 N. 3d st., St. Louis, Mo. (Branch—Phenix Bldg., Chicago, Ill.)  
**Phoenix Steel Wire Broom & Brush Co.**, 199 E. Randolph st., Chicago, Ill.  
**St. Thomas Car Wheel Co.**, St. Thomas, Ont., Canada.  
**STREET RAILWAY SUPPLY CO.**, Cleveland, Ohio.  
**SNEAD & HBB**, Louisville, Ky.  
**WAY FOUNDRY CO.** (The), 23rd and Wood sts., Philadelphia, Pa.  
**Wm. Wharton, Jr. & Co.** (Incorporated), 25th st. and Washington ave., Philadelphia, Pa.  
**Whiting Mfg. Co.**, Cedar Rapids, Iowa.  
**WHITNEY, A., & SONS**, Philadelphia, Pa.

**TRACK SCRAPERS.**  
**ANDREWS, FRANK H.**, 545 W. 33rd st., New York (vide Brakes).  
**Brill (J. G.) Co.**, Philadelphia.  
**Craig, Wm. P.**, 95 Liberty st., New York.  
**Day, Augustus**, 22 Park Place, Detroit, Mich.  
**Foote, Orlo A.**, Cleveland, O.  
**Grealey, The E. S. & Co.**, 5 and 7 Dey st., New York.  
**JOHNSON, TOM L.**, Indianapolis, Ind.  
**Laclede Car Co.**, 4500 N. Second st., St. Louis, Mo.  
**Lucas, H. H.**, Philadelphia, Pa.  
**Phoenix Steel Wire Broom & Brush Co.**, 199 E. Randolph st., Chicago, Ill.

**PUGH & RUSSELL**, Stewart Bldg., New York; Phenix Bldg., Chicago, Ill.  
**STREET RAILWAY SUPPLY CO.**, Cleveland, Ohio.  
**Van Dorn Iron Works**, Cleveland, O.

**TRACK SWEEPERS.**  
**ANDREWS, FRANK H.**, 545 W. 33rd st., New York (vide Brakes).  
**Brill (J. G.) Co.**, Philadelphia.  
**HOBBS & K. Co.**, Philadelphia.  
**STREET RAILWAY SUPPLY CO.** (The), 44 Walworth st., Brooklyn, N. Y.  
**Craig, Wm. P.**, 95 Liberty st., New York.  
**Grealey, The E. S. & Co.**, 5 and 7 Dey st., New York.  
**Haines Bros.**, 55 Broadway, New York.  
**LEWIS & FOWLER MFG. CO.** (The), 27 to 35 Walworth st., Brooklyn, N. Y.  
**MARTIN, RUFUS, & Co.**, 13 Park Row, New York.  
**PHENIX STEEL RAILWAY SUPPLY CO.**, Cleveland, Ohio.  
**Post & Company**, Cincinnati, Ohio.  
**PUGH & RUSSELL**, Stewart Bldg., New York; Phenix Bldg., Chicago, Ill.

**TRANSFER TABLES.**  
**Brill (J. G.) Co.**, Philadelphia.  
**Craig, Wm. P.**, 95 Liberty st., New York.  
**Foote, Orlo A.**, Cleveland, O.  
**FULTON FOUNDRY**, Cleveland, Ohio (vide Axles).  
**Haines Bros.**, 55 Broadway, New York.  
**HATHAWAY & ROBINSON**, 14 Case Bldg., Cleveland, O.  
**HORACE A. KEEFER CO.** (The), Kansas City, Mo.  
**LEWIS & FOWLER MFG. CO.** (The), 27 to 35 Walworth st., Brooklyn, N. Y.  
**PUGH & RUSSELL**, Stewart Bldg., New York; Phenix Bldg., Chicago, Ill.  
**STREET RAILWAY SUPPLY CO.**, Cleveland, Ohio.  
**Wm. Wharton, Jr. & Co.** (Incorporated), 25th st. and Washington ave., Philadelphia, Pa.

**TRANSIT.**  
**ALOE, A. S. & Co.**, 300 N. Fourth st., St. Lou's, Mo.

**TURN-OUTS.**  
**ANDREWS, FRANK H.**, 545 W. 33rd st., New York (vide Brakes).  
**Craig, Wm. P.**, 95 Liberty st., New York.  
**Day, Augustus**, 22 Park Place, Detroit, Mich.  
**FULTON FOUNDRY**, Cleveland, O. (vide Axles).  
**Haines Bros.**, 55 Broadway, New York.  
**HORACE A. KEEFER CO.** (The), Kansas City, Mo.  
**JOHNSON STEEL STREET RAIL CO.** (The), Johnstown, Pa. (vide Rails, Steel).  
**MARTIN, RUFUS, & Co.** (The), 27 to 35 Walworth st., Brooklyn, N. Y.  
**Metallie St. Railway Supply Co.**, Albany, N. Y. (vide Cable Tables).  
**Meyensburg, O. W. & Co.**, 204 N. 3d st., St. Louis, Mo. (Branch—Phenix Bldg., Chicago, Ill.)  
**PUGH & RUSSELL**, Stewart Bldg., New York; Phenix Bldg., Chicago, Ill.  
**St. Thomas Car Wheel Co.**, St. Thomas, Ont., Canada.  
**STREET RAILWAY SUPPLY CO.**, Cleveland, Ohio.  
**WAY FOUNDRY CO.** (The), 23rd and Wood sts., Philadelphia, Pa.  
**Wm. Wharton, Jr. & Co.** (Incorporated), 25th st. and Washington ave., Philadelphia, Pa.

**TURN TABLES.**  
**ANDREWS, FRANK H.**, 545 W. 33rd st., New York (vide Brakes).  
**Ayres, Abraham**, 502 to 518 W. 45th st., New York.  
**Brill (J. G.) Co.**, Philadelphia.  
**Craig, Wm. P.**, 95 Liberty st., New York.  
**Foote, Orlo A.**, Cleveland, O.  
**FULTON FOUNDRY**, Cleveland, O. (vide Axles).  
**Grealey, The E. S. & Co.**, 5 and 7 Dey st., New York.  
**Haines Bros.**, 55 Broadway, New York.  
**HATHAWAY & ROBINSON**, 14 Case Bldg., Cleveland, O.  
**HORACE A. KEEFER CO.** (The), Kansas City, Mo.  
**JOHNSON STEEL STREET RAIL CO.** (The), Johnstown, Pa. (vide Rails, Steel).  
**Kaestner Chas. & Co.**, 303 S. Canal st., Chicago.  
**LEWIS & FOWLER MFG. CO.** (The), 27 to 35 Walworth st., Brooklyn, N. Y.  
**Metallie St. Ry. Supply Co.**, Albany, N. Y. (vide Cable Tables).  
**PUGH & RUSSELL**, Stewart Bldg., New York; Phenix Bldg., Chicago, Ill.  
**SNEAD & HBB**, Louisville, Ky.  
**STREET RAILWAY SUPPLY CO.**, Cleveland, Ohio.  
**Wm. Wharton, Jr. & Co.** (Incorporated), 25th st. and Washington ave., Philadelphia, Pa.

**TYPE WRITERS (and Supplies).**  
**WYCKOFF, SPRAGNS & BENEDICT** (Remington Standard Type Writer), 196 LaSalle st., Chicago.

**UPHOLSTERY, MATS, ETC.**  
**BEADLE, EDWARD**, 1193 Broadway, New York (vide Folding Mats).  
**Errol, W. L.**, New Haven, Conn.  
**Goff, D. & Sons**, Pawtucket, R. I. (Mohair Plush).  
**Gold J. H. & Gold & Co.**, Philadelphia (vide Grips).  
**Hall & Eddy**, Mfg. Co. (The), 48 and 50 N. 9th st., Philadelphia.  
**HARTFORD WOVEN WIRE MATTRESS CO.** (The), 300 N. 2d st., Hartford, Conn.  
**Lynn & Pettit**, 707 Market st., Philadelphia, Pa.  
**MARTIN, RUFUS, & Co.**, 13 Park Row, New York.

**Warneck & Toffer**, 211 E. 22nd st., New York (vide Folding Mats).  
**VALENTINES.**  
**Baker, John & Co.**, 2 Liberty sq., Boston, Mass.  
**Brill (J. G.) Co.**, Philadelphia.  
**BROWNELL & WRIGHT CAR CO.**, 2309 Broadway, St. Louis, Mo.  
**COFFIN, DEVOR & CO.**, 176 Randolph st., Chicago, Ill.  
**Craig, Wm. P.**, 95 Liberty st., New York.  
**Gold J. H. & Gold & Co.**, Philadelphia (vide Grips).  
**Gludin & Joy**, Cleveland, O.  
**Grealey, The E. S. & Co.**, 5 and 7 Dey st., New York.  
**MARTIN, RUFUS, & Co.**, 13 Park Row, New York.  
**Murphy & Co.**, 239 M. Whorter st., Newark, N. J. (Branches—227 Broadway, New York; 556 Canal st., Cleveland, O.; 252 Washab ar., Chicago; 300 N. 4th st., St. Louis, Mo.)  
**Parrot Variash Co.**, Bridgeport, Conn.  
**Postmyer & Frazier**, 30 Frankfort st., New York.  
**Post & Company**, Cincinnati, Ohio.  
**PUGH & RUSSELL**, Stewart Bldg., New York; Phenix Bldg., Chicago, Ill.  
**Sherwin-Williams Co.** (The), Cleveland, O.  
**Shilman & Bolen**, Newark, N. J.  
**STREET RAILWAY SUPPLY CO.**, Cleveland, Ohio.  
**Valentine & Co.**, 245 Broadway, New York (vide Paints).

**VETERINARY SUPPLIES, ETC.**  
**Arnheim D.**, 52 Second av., Pittsburgh, Pa.  
**Hampshire's Homeopathic Medicine Co.**, 109 Fulton st., New York.  
**PUGH & RUSSELL**, Stewart Bldg., New York; Phenix Bldg., Chicago, Ill.  
**Roberts, F. P.**, 1741 Broadway, New York.  
**SOMERVILLE, DR. WM., & SONS**, 127 Erie st., Buffalo, N. Y.

**WOOD FILLEES.**  
**CHICAGO WOOD FINISHING CO.**, 143 and 145 S. Clinton st., Chicago, Ill.  
**WOOD STAPPLERS (for Cars).**  
**KUILLMANN CAR CO.**, 430 St. Clair st., Cleveland, O.

**WIRE AND WIRE ROPE.**  
**Broderick & Barson Wire Rope Co.**, St. Louis, Mo.  
**Bullivant & Co.**, 52 Mark Lane, London, E. C.  
**Cable Railway Co.**, 329 Market st., San Francisco, Cal.  
**ROBERTSON'S SONS**, JOHN A. Trenton, N. J. (Branches—117 and 119 Liberty st., New York; 171 and 173 Lake st., Chicago; 14 Drum st., San Francisco, Cal.)  
**WOOD FILLEES.**  
**CHICAGO WOOD FINISHING CO.**, 143 and 145 S. Clinton st., Chicago, Ill.  
**WOOD STAPPLERS (for Cars).**  
**KUILLMANN CAR CO.**, 430 St. Clair st., Cleveland, O.

At the present time opinion as to the best means of street car propulsion seems to be pretty evenly divided between electrical motors and wire cable, the real means in both cases being, of course, the steam engine. Electrical motors have received setbacks through lack of knowledge of how they should be constructed, and by putting theories in operation unmaturred; but knowledge is being slowly gained by experience, and this disadvantage will gradually disappear. Unwarranted claims have also frequently been made for electrical motors, and when they have been constructed in apparent ignorance of the principles of mechanics and put to work, the result has been practically a failure. For the purpose of being early in the field, inventors have put their motors at work when the result could be nothing but failure, and found in the end that their haste had been the cause of seriously delaying progress. But it should not be assumed that while progress is being made in electric motors, those interested in cable propulsion are standing still.—*Ex.*

# P. F. BURKE,

Successor to C. F. DEWICK & CO.,  
 Manufacturer of

# Patent Street Shoe Calks,

BLUNT AND SHARP.

WELDING DIES FOR SHARP, AND HORSE SHOERS' FOOT VISES.

360 Dorchester Avenue, BOSTON, MASS.

For Sale by Iron, Steel and Heavy Hardware Dealers. Send for Circulars.

J. MURRAY MITCHELL,  
President.

KARRICK RIGGS,  
Treasurer.

HENRY S. ISELIN,  
Secretary and Manager.

J. MURRAY MITCHELL,  
(DICKERSON & DICKERSON) Counsel.

# SAFETY ELECTRIC RAILWAY AND POWER COMPANY.

(DAFT SYSTEM.)

# ELECTRIC RAILWAY MOTORS

Electric Light and Power Machines. Electrical Conductors.

We are prepared to build and equip Railways with our Electric System and supply

## LIGHT —AND— POWER

Machines at the shortest notice.

Complete installation of Central Stations for the distribution of Power a specialty.

Cars equipped with the

## DAFT Electric System

can be lighted with the same current that operates the Motor.



DAFT ELECTRIC RAILWAY AT ORANGE, N. J.

From the *Los Angeles Illustrated Herald*, March, 1887.

The Los Angeles Electric Railway is a corporation organized for the purpose of constructing and operating electric railways in the City of Los Angeles.

The Los Angeles Electric Road is undoubtedly the most successful electric road in the United States. Col. Howland secured the benefit of the working of other roads and adopted the best improvements that experience could suggest. The speed of the road is usually from 10 to 12 miles per hour, as fast as is deemed safe for the streets of the city. The apparatus is under the most perfect control, and can be stopped on the instant, and if necessary, be reversed in motion. Cars have been run at times at a speed of 20 miles per hour.

The road has been running nearly two months and not failed a single day. It has carried in a single afternoon on three cars, a distance of three miles, fifteen hundred passengers.

The Electric Railway Company has now in operation three miles of electric railway on Pico Street, and are building two miles more to reach the Plaza.

The cost of construction is about one-third of a cable road. The cost of maintenance about 60 per cent of a cable road. Its speed can be made greater.

The cost of running an electric road can be estimated at one-half of a horse road, and its capacity four fold greater.

This road is one of the many enterprises that Los Angeles contributes to astonish the visitor, and is daily visited by hundreds of our sojourners.

From the *Los Angeles Times*, March 5, 1887.

## THE ELECTRIC ROAD.

### A FLATTERING OPINION.

H. C. Moore, Prosecuting Attorney of San Jose, and prominently connected with street railroads in that city and San Francisco, has been here for several days on business—with which he has contrived to mingle considerable pleasure. Mr. Moore is one of the owners of the horse-car system in San Jose—the system embracing about five miles of track, and an investment of about a quarter of a million dollars. The franchise of the company runs out in a year, and the company has applied for a renewal with the privilege of turning the system into an electric road.

To find out the exact facts in the case, Mr. Moore came down here to see for himself. He has examined the Pico Street electric road thoroughly, ridden over it, and is surprised and delighted with it.

After a couple of days' chase, a *Times* representative caught Mr. Moore yesterday, and had a short conversation with him on the subject of his visit. Mr. Moore said: "I heard about your electrical road; I came down and see it for myself, and am surprised at the success and smoothness of your road. I have ridden over it, and must say it is the smoothest riding road I ever rode on. You actually cannot tell, unless you watch some stationary object, just when you start and when you stop. It

Address all communications to

**SAFETY ELECTRIC RAILWAY AND POWER CO.**  
Office, 41 & 43 WALL ST., NEW YORK. Factory, GREENVILLE, N. J.

Estimates,  
Catalogues,  
and any information furnished on application.

We guarantee the successful operation of our system.

## Heaviest Grades

NO OBSTACLE.

On receipt of full particulars, we will send you exact estimate of the cost of equipment and operation under

## Our System.

We have the only absolutely self-regulating Motor in the World.

Is a wonderful thing. Now, the Market Street road in San Francisco is the finest cable road on earth. It cost hundreds of thousands of dollars a mile. Your electric road is built very cheaply on an ungraded street whose soil is like ashes when dry, and like mortar when wet; and still, for comfort and smoothness, it is perfection. It is as much ahead of the Market Street cable road as the Market Street road is ahead of a horse railroad. I am more than satisfied with its workings.

From the *Electrical World*, March 26, 1887.

The Daft road, at Los Angeles, is working admirably. The road carried 14,952 passengers during February, and is developing a large and rapidly growing business. It is proposed to adopt the system for a road at San Jose, using a simple form of conduit system. Mr. H. C. Moore, one of the large owners of the San Jose road, which has hitherto been run by horses, inspected the Los Angeles road recently and pronounced a strongly favorable opinion on its merits.

BALTIMORE, Sept. 25, 1886.

**SAFETY ELECTRIC RAILWAY AND POWER CO., NEW YORK.**  
*Gentlemen:*—In answer to yours of the 23d inst., making inquiries in relation to the Baltimore & Hampden Electric Railroad, I have to say that its success by the change from horse and mule power to electric power under the Daft System has exceeded my highest expectations. It has largely increased the travel on the route, and at a less operating expense than horse power. The road has been running more than a year by electricity with as much regularity as any road in the country. I find less difficulty in getting men to run the motors properly than I do to get men to run the ordinary horse car properly. The road is now being run by persons who before their employment here were unfamiliar with electrical affairs.

T. C. ROBBINS, GENERAL MANAGER.

**REPORT OF T. C. ROBBINS, Esq., Manager of Baltimore Union Passenger R. R. Company, showing results of running the Baltimore & Hampden Road by DAFT ELECTRIC MOTORS.**

To the year ending September 1st, 1885, with horses, at a speed of 4.033 miles per hour:	In the year ending September 1st, 1886, with Electricity, at a speed of 8 miles per hour:
Passengers carried were..... 227,155	Passengers carried were..... 311,441
Gross Earnings were..... \$13,357.75	Gross Earnings were..... \$15,357.05
Cost of Motive Power was... 7,117.50	Cost of Motive Power was... 4,380.00
Cost of Motive Power per Passenger per mile was..... .0156	Cost of Motive Power per Passenger per mile was..... .007
I. An Increase in Traffic of..... 37 per cent nearly	II. A Reduction in Cost of Motive Power in Gross of..... 63 per cent.
III. A Reduction in Cost of Motive Power in Gross per Passenger per mile of..... 55 per cent.	



# DIRECTORY SUPPLEMENT.

# The Street Railway Gazette.

VOL. II.

CHICAGO.

DECEMBER, 1887.

NEW YORK.

No. 12.

## SLIDING DOWN!

NEW BEDFORD, MASS., October 10th, 1887.

Just after 10 o'clock Saturday evening, car No. 23, going down Elm street from the Fair in the Rink got out of the driver's control, the wheels slipping on moist leaves on the rails. The brakes stopped the wheels from turning, but they slid. The driver did not attempt to turn the corner of Sixth street, and his car ran into a tree. The horses cleared themselves and were caught at the foot of Elm street. The passengers in the car were badly shaken up. Mrs. James H. Kenealy, residing on Grinnell street, was badly bruised, and a Fairhaven lady's arm was wrenched severely. The glass in the front end of the car was shattered, and the bonnet on the front was smashed.—*The Evening Standard.*

This, as well as numerous other accidents would have been prevented had the cars been equipped with the  
**RELIABLE SAND BOX.**

**W. T. BUTLER, General Manager,**

19 Tremont Row, Boston, Mass.

## THE BRYDEN FORGED HORSE-SHOE WORKS, LIMITED.

**CATASAUQUA, PENN.**

MANUFACTURERS OF

## The Bryden Forged Solid Calk HORSE AND MULE SHOE.

ADOPTED BY THE FOLLOWING STREET RAILWAYS:

*The Third Avenue R. R. Co., Eighth Avenue R. R. Co., Broadway & Seventh Avenue R. R. Co., of New York City; Bushwick R. R. Co., Brooklyn City and Newton R. R. Co., of Brooklyn; Philadelphia Traction Co, Citizen's Passenger R. R. Co., Second & Third Street R. R. Co., of Philadelphia; Metropolitan R. R. Co. of Washington, D. C.; North Chicago R. R. Co., Chicago City R. R. Co., West Division R. R. Co., of Chicago, Ill.; New Orleans City & Lake R.R., Co., of New Orleans, La, etc. etc.*

**J. B. WHITE, MANAGER SALES DEPARTMENT,**

234 Lake Street, CHICAGO, ILLS.

# FRANK H. ANDREWS,

SUCCESSOR TO

ANDREWS & CLOONEY,

MANUFACTURER AND CONTRACTOR FOR

CONSTRUCTING STREET RAILWAYS.

THE BUILDING OF

# CABLE ROADS

AND FURNISHING MATERIALS FOR SAME, A SPECIALTY.

*All kinds of Steel and Steel Grooved Rails, Straight or Bent to any Radius. Knees, Fishplates, Spikes, Bolts, Etc., Etc.*

## MACHINERY:

*Wheel Presses, Wheel Bowers, Axle, Lathes, Drills, Etc., either for Steam or Hand Power.*

PROMPTNESS AND REASONABLE PRICES.

SEND FOR ILLUSTRATED CATALOGUE.





JOHN J. BRODERICK, Prest.

JOS. D. BASCOM, Sec. & Treas.

# Broderick & Bascom Rope Co.

Manufacturers



# ROPE

## Cable Ropes

FOR

### STREET RAILROADS.

# WIRE

St. Louis, Mo.

# The Horace A. Keefer Co., KANSAS CITY, MO.

## Street, Cable, Motor & Steam Railway

EQUIPMENT AND TRACK MATERIAL A SPECIALTY.

### PRICE'S IMPROVED FARE BOX.

THE BEST IN THE MARKET.

The ringing of a gong for each fare, checks the passenger as well as the driver, and hence conductor's bell punch is unnecessary. It is positively the best fare collector in the *World*.

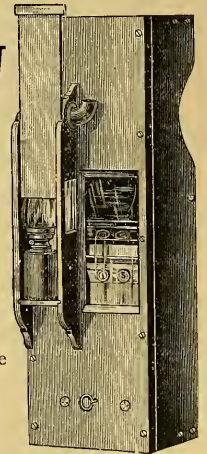
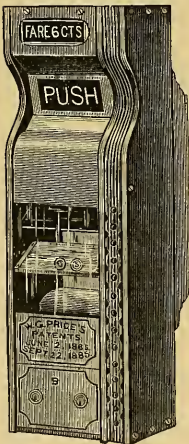

### Corliss Engines, Safety Boilers, Feed-Water Heaters, Pumps,

WINDING GEAR AND CABLE OUTFITS COMPLETE

Can always secure our customers good bargains in second-hand Supplies and Equipments.





# KUHLMANN CAR CO.

BUILDER OF

# STREET RAILWAY CARS

OF EVERY DESCRIPTION.

ALL KINDS OF WOOD WORK FOR INTERIORS A SPECIALTY.

Street Railway Companies building their own Cars will do well to correspond with us.

Office: 490 St. Clair Street, CLEVELAND, O.

# CLEVELAND FOUNDRY,

MANUFACTURERS OF

## Car and Locomotive Wheels, *Either Chilled or Steel Tired, with or without axles.*

*Street Railway Wheels, Turnouts and Turntables, Patent Chilled Face R. R. Frogs, Engine and Heavy Castings a Specialty.*

### GRADED STABLE CUTTERS WITH STRAIGHT OR CURVED COVER.

Descent 1/2 inch per foot. Pieces 5 feet lengths. Short pieces furnished to suit any length. Spouts to connect with sewer.

They control and make N. P. Bowler's Patent Street Railway Wheel. The tire of this wheel is cast separately from the hub and spokes; the latter is made of soft strong iron, and is perfectly free from strain—therefore can be made much lighter and more durable. The tires and the spokes or center of the wheel are made perfectly interchangeable so that when the tire or rim is worn out another can be put in its place by any employee with no other tool than a common wrench.

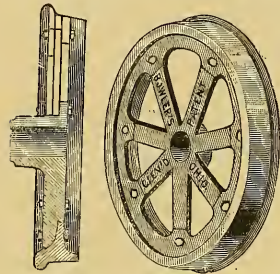

**BOWLER & CO., 10 to 24 Winter St., CLEVELAND, OHIO.**

# Use IRON CLAD PAINT

FOR YOUR CARS, BARNs AND BUILDINGS.

OFFICE OF EAST CLEVELAND RAILWAY CO.

IRON CLAD PAINT CO.:  
Gentlemen:—This Company, for the last 17 years, has extensively used your "Iron Clad Paint" upon its buildings, roofs and cars. For durability, protection against fire, and cheapness, there is no paint that will compare with it. It is equally as good for fine as for coarse work; it polishes beautifully. The paint upon the bodies of our cars which was put on ten years ago, is as firm and good as when first put on, while the other kinds of paint put on at the same time, has been renewed twice; nothing has been done to the Iron Clad except new coats of varnish.

EDWIN DUTY, Superintendent.  
WM. KRUEGER, Painter.

OFFICE OF THE MASTER CAR BUILDER.

Toledo, Wabash & Western R'y.  
Toledo, O., Feb. 18, 1875.

IRON CLAD PAINT CO., Cleveland, O.:

Dear Sir:—In reply to your letter of the 9th inst., as to the use of the "Iron Clad Paint" by this Company, would say: That we have been using it for the past year on our passenger and baggage cars, and are very much pleased with it. We can cheerfully recommend it for its body, durability and cheapness. Accompanying this you will find a sample of the color we use on our coaches, which is obtained by grinding together 20 pounds of Rosin and one pound Lampblack.

Respectfully,  
U. H. KOHLER, M. C. B.

THE  
PUREST.  
THE MOST  
FIRE-PROOF.  
THE MOST  
DURABLE  
PAINT  
IN THE  
WORLD.

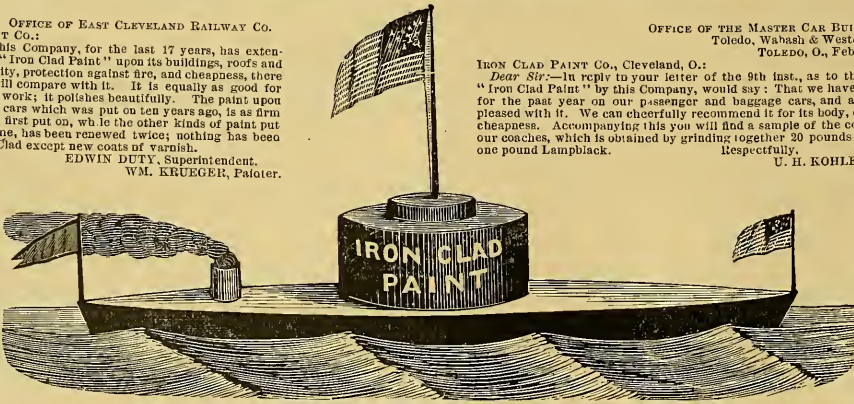

Trade Mark Patented—Paint Patented

THE  
Cheapest.  
THE MOST  
Economical.  
THE MOST  
Water-Proof  
PAINT  
IN THE  
WORLD.

Refer to East Cleveland Street Railway Company, who have used it for nearly Twenty Years.

# IRON CLAD PAINT COMPANY, - CLEVELAND, OHIO.

A Discount of 5 per cent to any one mentioning this Advertisement.





❖ ——— **KAIL'S** ——— ❖

# COMBINED FARE BOX AND CHANGE MAKER



EMBODIES THE ONLY PERFECT SYSTEM

OF

## COLLECTING FARES AND MAKING CHANGE

ON STREET CARS.

It cannot be robbed without violence.

Adopted by many street railroad companies.

Is, at all times, secure from theft, although the driver leaves the car.

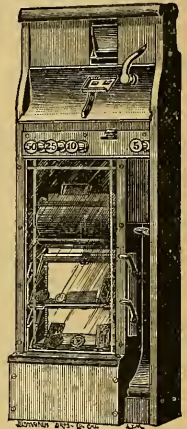

## Kail Manufacturing Company,

60 and 62 W. VAN BUREN STREET, CHICAGO, ILL.

OFFICE OF

*People's Passenger Railway Company.*

*Eighth and Dauphin Sts.*

Philadelphia, Nov. 12th, 1887.

James M. Swem, Esq.,

My Dear Sir:

We have had in practical use for over one month one of your Patent Switches, and it has done its work so well and so very satisfactorily that I can cheerfully recommend it to all Street Railway men as being the best switch now in use and by far the cheapest in the market. A trial will convince anyone of the wisdom of its adoption.

Very Respectfully,

Chas. S. Whiting,

*Gen'l Superintendent.*





THIS SPACE RESERVED FOR  
**THE RIES ELECTRIC RAILWAY AND TRACTION  
 INCREASING SYSTEM.**

FOR PARTICULARS, ADDRESS—

**A. H. Henderson, Bus. Mgr.**

27 CHAMBER OF COMMERCE BUILDING,

BALTIMORE, MD.

**H. K. PORTER & CO., Pittsburgh, Pa.**

—BUILDERS OF—

**Light Locomotives**

—FOR—

**EVERY VARIETY OF SERVICE.**

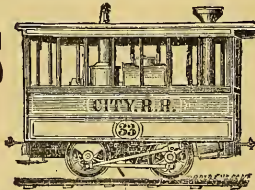

NOISELESS

**Street Motors**

6 x 10, 7 x 12, 8 x 12, 9 x 14, 9½ x 14, 10 x 16,  
 and 12 x 18 Cylinders for Narrow  
 or Wide Gauge.

**FINISHED PARTS KEPT ON HAND READY FOR EARLY DELIVERY.**

CATALOGUE AND PHOTOGRAPHS FURNISHED ON APPLICATION.

**The Hoefinghoff & Laue Foundry Co.**

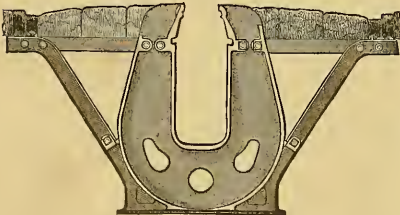

**General Foundry Work,**

**Heavy Castings and Cable Railway Work**

**A SPECIALTY.**

Front, Lawrence and Pike Streets.

Office, 154 E. Front Street, CINCINNATI.





**The Hale & Kilburn Manfg. Co.,**  
EXTENSIVE MAKERS OF PATENTED  
**Street Car Seats,**  
 Of Every Description.

Our Patent Spring Seats covered with Rattan or Carpet are fast being adopted by the best railroads in the country.

**Seats for Steam Cars**  
 A SPECIALTY.

OWNERS AND MAKERS OF ALL THE COBB PATENTS.

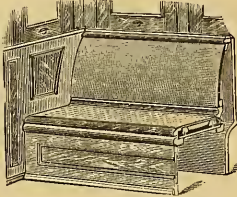

*Cut showing car with rattan seat and back without springs.*

**REFERENCES:**

Broadway line (Pullman cars) New York; Grand St. line, 3d and 4th Ave. lines, N.Y. Chicago City R.R. Chicago W. Div. line and new Adams St. line, Chicago. E. Cleveland R. R. Co. and Woodland Ave. and West Side R.R. Co. Cleveland. Union line, St. Louis, 2d and 3d St. R.R. Co. Frankford & Southwark R.R. Co. Union line, Chestnut & Walnut R. R., Ridge Ave. R.R. or any other road in Phila., and 100 others elsewhere.

Many R. R. Cos. use our Rattan Pat. Canvas Lined Seats for Summer and cover the same with carpet for Winter. This method of seating we recommend as durable and economical, for the reason both a Summer and Winter Seat is obtained in one.

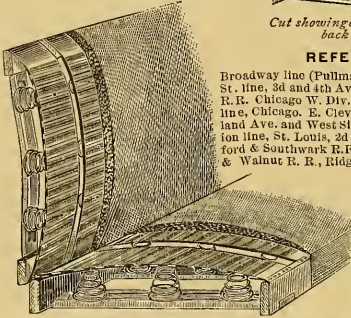

*Cut showing section of rattan seat and back; also made for carpet.*

Estimates and Particulars cheerfully given (mention this paper) Satisfaction Guaranteed. A Trial Solicited.

OFFICES, 48 & 50 NO. SIXTH ST.  
 FACTORIES, 615 to 621 FILBERT ST.

Philadelphia, Pa.

**CHADBOURNE**   
 **& HASTINGS,**

— AGENTS FOR —

**The Sprague**  
**Electric Railway**  
**& Motor Co.**

*Complete Equipment of Street Railways under the Sprague Patents. Successful Operation Guaranteed in every Particular.*

Exact estimates will be furnished for the cost of equipping any road, when complete details are supplied to us on blanks which we will furnish on application.

Forrest Building, Philadelphia, Pa.

RESERVED FOR CUT OF

**The Messier Car Brake.**

**CHEAP — SAFE — EFFECTIVE — RELIABLE.**

After thoroughly testing this brake for several months the State Street Road in Albany, N. Y. (having a grade of 10' in 100') decided that it was the only one ever applied that could be relied upon to stop a large Summer Car, carrying 52 passengers, without setting the wheels. The shoes used on this brake are guaranteed for one year.

**W. N. LEWIS,**

8 State Street, - - - ALBANY, N. Y.



\*Ridge Ave. Pass. Ry. Co. (Ridge and Susquehanna Aves.)—Pr E. B. Edwards, Sec & Tr Wm. S. Blight, Spt Wm. Myers; 15 m, 5-1/2, 47 lbs; 60 c, 350 h. Roxborough & Barren Hill Inclined Plane Ry. Co.—Pr C. J. Walton, Sec W. H. Lewis.

Schuykill River Pass. Ry. Co.—Pr O. Hopkinson, Sec J. C. Dawes. Second & Third Sts. Pass. Ry. Co. 2653 Frankford Ave.—Pr Alex. M. Fox, Sec C. F. Mallock, Spt Wm. C. Schenck; 5-2/3, 43 to 55 lb; 11 c, 475 h. Seventeenth & Nineteenth Sts. Pass. Ry. Co. (423 Walnut St.)—Pr Mathew S. Quay, Sec John H. Proctor; 7.5 m, leased to Philadelphia Traction Co.

The Great & Coates Sts. Phila. Pass. Ry. Co. (101 Chestnut St.)—Pr Moses A. Dropsie, Sec Lewis T. Remslaw; leased to Philadelphia Pass. Ry. Co. Thirtieth & Fifteenth Sts. Pass. Ry. Co. (1 c, cor. 15th and Cumberland Sts.)—Pr Thos. W. A. Reilly, Sec Alex. Koudak, Spt Wm. F. Cooper; 14 m, 5-2 c, 43 lbs; 55 c, 530 h.

Union Pass. Ry. Co. (423 Walnut St.)—Pr Wm. H. Kemble, Sec & Tr John B. Peelle; 70 m, leased c, 172 h, leased to Philadelphia Traction Co. West Phila. Pass. Ry. Co. (in w. cor. 41st and Haverford Sts.)—Pr P. A. H. Widener, Sec D. W. Dickson, Spt James T. Gorinan, Engr A. R. White; 15.5 m, leased c, 172 h, leased to Philadelphia Traction Co.

Wilmington & Chester Pass. Ry. Co.—Pr Geo. J. Whitney, Sec F. L. Stephenson, Spt L. C. Horton; 6 m, 5-2/3 c, 45 lb; 18 c, 36 h. Citizens Pass. Ry. Co.—Pr John C. Jones, Sec C. M. Gornly, Spt Murray Verrier; 18 m, 5-2/3 c, 45, 47 and 52 lb; 48 c, 346 h. This Co. operates the Transverse Pass. Ry.

Pitts. & Allegheny & Manchester Pass. Ry. Co.—Pr Chas. Atwell, Sec & Tr Chas. Selbert, Spt James C. Cotton; 10 m, 5-2/3 c, 47 lb; 44 c, 261 h. Pitts. & Kensington Pass. Ry. Co. (50th and Carson Sts.)—Pr W. W. Patrick, Sec C. H. Agnew, Spt John Deloney; 8.75 m, 5-2/3 c, 47 lb; 25 c, 177 h. Pitts. & East End RR. Co.—Pr Wm. L. Chaifour, Spt Wm. C. W. Harris.

Pitts. & McKeesport & Leoka St. Ry. Co.—Pr Wm. C. W. Harris. Pitts. & Wilkinsburg St. Ry. Co. Pitts. Union Pass. RR. Co.—Pr Chas. Atwell, Sec Chas. Selbert, Spt James C. Cotton; 10 m, 5-2/3 c, 47 lb; 44 c, 261 h. Second Ave. Pass. Ry. Co. (Second Ave.)—Pr George Fawcett, Sec & Spt James F. Fawcett; 6 m, 5-2/3 c, 47 lb; 3 c, 40 h.

South Side Pass. Ry. Co.—Pr Geo. J. Whitney, Sec F. L. Stephenson, Spt W. M. Roshoroff; 5 m, 5-2/3 c, 45 lb; 12 c (one 6 in use), 40 h. The Pitts. & West End Pass. Ry. Co.—Pr J. C. Reilly, Sec Thos. S. Bigelow, Spt W. J. Harris; 10 m, 5-2/3 c, 45 lb; 23 c, 100 h. The Traction St. Ry. Co.—Pr Thos. M. Bigelow, Sec The Transverse Pass. Ry. Co.—Pr C. L. Magee, Sec W. R. Ford, Spt M. M. Elliot; 6.333 m, 5 m, 5-2/3 c, 45 lb; 40 c, 340 h.

Williamsburg & East Liberty Ry. Co.—Pr E. J. Allen, Sec W. H. Allen; 8 m. Potsville (7.472). Pitt. St. Car. Co.—Pr Spt Isaac Everett, Sec W. W. Mulligan; 1.75 m, 5-2/3 c, 45 lb; 23 c, 100 h. Potsville (13.253). People's Ry. Co.—Pr Thos. A. Reilly, Sec & Spt Wm. D. Foliard; 9.5 m, 18 c, 45 lb; 23 c, 100 h. Perkiomen Ave. Pass. Ry. Co. (Perkiomen Ave. & 19th St.)—Pr Ochs. Brenselor, Sec Isaac Hiestor, Spt John B. Houpp; 4.6 m, 5-2/3 c, 38 lbs and 45 lb; 18 c, 75 h.

\*Reading City Pass. Ry. Co.—Pr Benj. F. Owen, Sec A. M. Muhleberg, Spt J. A. Riggs; 2.3 m, 5-2 c, 45 lb; 2 c, 56 h. Sayre (729). Sayre St. Ry. Co.—Pr H. Elmer. Sayre (45.860). People's St. Ry. Co.—Pr Wm. Mathews, Sec Horace E. Hand, Spt W. Pearce; 10 m, 25, 40 and 62 lb; 20 c, 90 h. Scr. Suburban Pass. Ry. Co.—Pr H. S. Briggs, Sec S. Sanderson, Spt B. F. Killian; 4 m, 5-2/3 c, 35, 40 and 52 lb; 7 c; electric power (Van Depoele system); engines, 350 hp.

The Noyah & Stratton RR. Co.—Pr G. C. Clark, Sec T. C. Snow; 6 m, 5-2/3 c, 38 lbs and 45 lb; 18 c, 75 h. Steeple (6.477). Stratton St. Ry. Co. Stroudsburg (1.860). Strou. Pass. Ry. Co.—Pr Spt & Tr J. Lantz, Sec Jacob Honser; 4 m, 5-2/3 c, 45 lb; 23 c, 100 h.

Wilkes Barre (23.339). Coalville Pass. RR. Co.—Pr G. W. Kirkendall, Sec G. Levealand, Spt A. S. Orr; 2.5 m, 20 and 34 lb; 3 c, 12 h. \*Wilkes Barre & Kingston RR. Co.—Pr Spt Wm. J. Harvey, Sec A. J. Davis; 3 m, 5-2 c, 30 and 45 lb; 1 c, 25 h. Williamsport (18.934). Will. Pass. Ry. Co.—Pr Robt. P. Allen, GM S. A. Alibert, Sec R. J. G. Trimmer, Spt J. F. Fidler; 3 m, 48 lb; 3 c, 13 h.

RHODE ISLAND.

Pawtucket (19.030). Pawtucket Pass. Ry. Co.—Pr Arnold B. Chace, Sec B. A. Jackson, VP & GM E. M. Cole; 3.5 m, 36 lb; 7 c (one h); 26 c, 124 m. Providence (104.857). Union RR. Co.—Pr Jesse Metcalf, VP & GM D. F. Longstreet, Sec C. A. Babcock, Engr Geo. C. Tugley; 53.4 m, 47 and 54 lb; 280 c, 1294 h (May 1).

Woonsocket (16.050). Woonsocket St. Ry.—Pr Horace H. Jenckes, Sec & Engr Willard Kent; 3.5 m, 30 and 50 lb; 7 c, 8 c, 40 h; Bentley-Knight electric ry. system (with Thompson traction motor).

SOUTH CAROLINA.

Charleston (49.984). Char. City Ry. Co. (4 Broad St.)—Pr John S. Riggs, Secs Evan Edwards & Frank F. Whilden, Spt John H. Mohlenhoff; 10 m, 4-3/4 c, 38 and 42 lb; 30 c, 116 h, 1 m. Enterprise RR. Co.—Pr J. R. Ravenel, Sec W. E. Haynie, Spt W. Passalaglio; 16 m, 5-2 c, 42 lb; 34 c, 67 h, 31 m. Columbia (10.098). Col. Ry. Co.—Pr S. E. Erson (New York), Sec E. M. Cole (32 Liberty St., New York); 5 m, 30 lb; 6 c, 38 h. Greenville (61.199). Street Ry. Co. of the City of Greenville (104 Washington St.)—Pr George W. C. Gower, Sec G. G. Wells, Spt F. H. Reilly; 2.25 m, 5-0 c, 18 lb; 7 c, 4 h, 30 m. Mountbrielle (—). Middle St. Sullivan's Island RR. Co.—Pr F. B. Callaghan, Sec F. W. Widen, Spt E. B. Bunley; 2.6 m, 4-9 c, 30 lb; 7 c, 1 h, 13 m.

TENNESSEE.

Athens (1.100). The Athens Mineral Land & Improvement Co.—Pr T. M. Burkett, Sec W. D. Henderson; 1 m, 20 lb; 1 c, 4 m, 3 stn m. Chattanooga (23.828). City St. RR. Co.—Pr J. H. Warner, Sec R. G. Gaskill, Spt Geo. Smith; 4 m, 14 c, 27 c, 124 m. Clarksville (3.880). Clarks. St. Ry. Co.—Pr J. F. Shelton, Sec J. W. Faxson; 2 m, 16 lb; 7 c, 18 m. Jackson (5.577). Jackson & Suburban St. Ry. Co.—Pr C. H. Heath (Stoux City, Ia.), Sec R. B. Crawford (Wayne, Neb.). Knoxville (9.893). Knoxville St. RR. Co. (336 Broad St.)—Pr W. P. Chamberlain, Sec T. L. Leavelle; 7 m, 16 lb; 7 c, 124 m. Mabry Bell Ave. & Hardee St. Ry. (336 Broad St.)—Pr John S. Van Gilder, Sec T. L. Leavelle; 1.25 m, 14 m, 22 lb; 4 c, 28 h. Market Square St. Ry. Co.—Pr John S. Van Gilder, 150 Gay St.; Sec W. B. Henderson, Spt L. C. Rogers, Engr Murray Nicholson; 2 m, 22 lb; 4 c, 4 c, 15 h, 3 m.

Memphis (33.598). Citizens St. RR. Co. (474 Main St.)—Pr Napoleon Hill, VP & GM Thos. Barrett, Sec R. Dudley Fryacker; 40.5 m, part 5 c, 38 lbs and 45 lb; 160 c, 804 m. East End St. Ry. Co.—Pr W. M. Sneed, Sec J. W. Falls, Engr G. B. Fleece; 10 m, 35 lb; 7 c, 3 stn m. Union RR. Co. (104 Washington St.)—Pr Wm. H. Cherryl, Spt John P. McGee, Sec H. B. Simblen, Spt Dangerfield Deaderick, Engr Wilber F. Foster; 14.25 m, 16 to 38 lb; 17 c, 124 m. Nash. & Edgefield St. RR. Co. (91 N. Cherry St.)—Pr Jas. H. Yarbrough, rest of officials same as McGee & Mt. V. H. RR. Co.; 62.5 m, 5 lb; 16, 20 and 38 lb; 21 c, 101 m. Overland Ry. Co.—Pr O. F. Noel, Sec & Tr Jas. F. Caldwell; 9.5 m, 45 lbs; 6 c, 3 1/2 stn m.

South Nash. St. RR. Co.—Pr W. M. Duncane, Sec & Spt L. L. Fulery; 4.5 m, 5 lb; 16, 20 and 32 lb; 12 c, 72 m.

TEXAS.

Austin (10.960). Anstn. St. Ry. Co. Brenham (4.101). Br. St. RR. Co.—Pr T. J. Pampell, GM E. B. Randle, Sec John A. Roodie; 2 m, 4 c, 20 lb; 3 c, 18 m. Dallas (10.358). Dallas & Collin St. Ry. Co.—Pr I. E. Henderson, Sec W. C. Connor, Spt S. S. Kingsberry; 13 m; 25 c, 1 h, 200 m. Denton City (3.475). Denton St. Ry. Co.—Pr C. A. Waterhouse, Spt J. J. Campbell; 3.25 m. El Paso (736). El P. St. Ry. Co.—Pr J. F. Crosby, Sec & Spt G. N. Marshall; 6 m; 18 c, 40 m. Fort Worth (8.571). Ft. Worth St. Ry. Co.—Pr K. M. Vanzandt, Spt J. T. Payne; 7.5 m, 4 c, 25 and 38 lb; 16 c, 86 m.

Galveston (2.667). Galvs. St. Ry. Co.—Pr Sam Lazarus, Sec & Spt Zac. Farner; 3 m, 3-8 c, 16 lb; 2 c, 43, 34, 14 m. Galveston (22.245). Galveston City RR. Co. (P.O. Box 373)—Pr Wm. H. Muelair, Spt J. L. Kennard; 15 m, 3 c, 16 lb; 2 c, 39 lb; 25 and 30 lb; 7 c, 214 m. Gulf City Ry. & Real Estate Co.—Pr J. H. Burnett, Sec Theo. C. Becker, Spt Uria Hambrick; 15 m, 4 c; 20, 25 and 30 lb; 4 c; 27 c; 194 m.

Houston (10.358). Houston St. Ry. Co.—Pr Wm. H. Muelair, GM H. F. McQuigge, Sec H. E. Bailey, Spt Henry Freund; 14 m, 30 lb; 40 c, 114 m. Longview (653). Lam. Springs St. RR. Co.—Sec W. H. Little, Spt E. E. Madsen; 2.5 m, 22 lb; 7 c, 6 c, 11 m. Longview (1.525). Longview St. RR. Co.—Pr Geo. D. Harrison, Sec P. L. Whaley, Spt J. L. Kennard; 7.5 m, 3 c, 16 lb; 2 c, 39 lb. Paris (3.980). Paris Ry. Co. (P.O. Box 375)—Pr D. F. Lattner, Sec & Spt C. G. Gwynn; 1.5 m, 22 lb; 7 c; 3 lbs; 4 ftas; 13 m, 3 stn m.

San Antonio (20.000). San Antonio St. Ry. Co.—Pr Geo. J. Hill, Spt Chas. M. Mack, Spt J. M. Moss; 3 m, 4 c, 16 lb; 1 c, 3 h. San Antonio St. Ry. Co.—Pr A. Belknap, Sec E. R. Norton, Spt J. Bobb; 18 m, 4 c, 30 lb; 1 c, 3 h. Sherman (9.093). Sher. City Ry. Co.—Pr C. W. Batsell, Sec C. W. Batsell, Jr, Spt W. H. Bates; 4.1 m, 5 c, 16 and 20 lb; 7 c, 5, 50 m. Waco (7.425). Waco St. Ry. Co.—Pr Wm. H. Reaman, Sec W. R. Kellam, Spt J. W. Seabury; 7.5 m, 14 and 25 lb; 14 c, 54 m.

UTAH.

Ogden City (5.059). Og. City Ry. Co.—Pr W. W. Shurtliff, VP & Spt O. P. Arnold, Sec & Tr H. B. Young; 3 m, 20 lb; 4 c, 19 h. Salt Lake City (20.768). Salt Lake City RR. Co.—Pr John Taylor, Sec Dd. McKenzie, Spt Orson F. Arnold; 12 m, 20 lb; 2 c, 7 h, 100 m.

VIRGINIA.

Burlington (11.365). Winook & Bur. Horse RR. Co.—Pr W. A. Woodbury, Sec Geo. Wales, Spt H. B. Walker, Engr Jos. Depp; 3 m, 4-8 c, 25 lb; 7 c, 8 c, 30 h. Rutland (7.502). Rut. St. Ry. Co. (7 1/2 Centre St.)—Pr N. S. Woodford, Sec Geo. H. Cheney, Spt M. McKeogh; 8.5 m, 20 lb; 7 c, 9 c, 30 h.

VIRGINIA.

Charlottesville (2.676). Char. & University St. Ry. Co.—Pr R. P. Valentine, Sec C. P. Benson, Spt & Engr H. D. Porter; 1.5 m, 16 lbs; 2 c, 3 c, 12 h. Lynchburg (15.629). Lych. St. Ry. Co.—Pr D. E. White, Sec Stephen Adams, Spt W. M. Payne; 4 m, 5-1 c, 20 and 26 lb; 7 c, 15 m, 25 m. Norfolk (31.965). The Norfolk City RR. Co.—Pr J. B. Whitehead, Sec & Tr G. C. Whitehead, Spt E. W. Savage; 3.25 m, 5-2 c, 43 lb; 20 c (1) two-1, 2 one-1, 70 h.

Petersburg (31.556). Pet. St. Ry.—George Beadle, proprietor; 3 m, 5 c, 42 and 47 lb; 9 c, 30 h. Richmond (63.600). Rich. St. Ry. Co.—Pr J. L. Schoolcraft, G M C. M. Bolton, Spt Charles Seiden; 7.5 m, 30 and 40 lb; 42 c, 185 h. Rich. & Manchester St. Ry. Co.—Pr J. E. Taylor, Sec & Tr Jackson Brandt, Spt B. R. Seiden; 3.5 m, 38 lb; 3 c, 26 h. Union Pass. Ry. Co.—Sec & Tr John F. Barry; 13 m; Sprague electric m.

WASHINGTON TERRITORY.

Seattle (3.533). The Seattle St. Ry. Co.—Pr & GM E. H. Osgood, Sec Geo. Klunear; 4.5 m, 25 and 35 lb; 7 c, 25 h. Spokane Falls (350). The Spokane St. Ry. Co.—Pr W. J. Brown, VP & GM A. J. Ross, Sec & Tr H. C. Mizell; 1.5 m, 20 lb; 5 c, 13 h.

WEST VIRGINIA.

Wheeling (30.736). City Ry. Co.—Pr Dr. Geo. B. Caldwell, Sec Frank P. Hall, Spt Michael Lotous; 10 m, 5-2/3 c, 45 lb; 16 c, 80 h. Wheeling & Elm Grove RR. Co.—Pr J. D. DuBois, Sec E. J. Rutter, Spt C. Hirsch; 7 m, 30 lb; 12 c, 4 stn m (Baldwin).

WISCONSIN.

Appleton (8.005). Ap. Electric St. Ry. Co.—Pr J. E. Harriman, Sec Frank W. Harriman, Spt Geo. Johnson, Engr N. M. Edwards; 4.5 m, 33 lb; 1 c, 5 c, 5 electric motor (Van Depoele system). Eau Claire (10.119). Eau Cl. St. Ry. Co.—Pr A. G. Bradstreet (35 Pine St., New York), Sec Weston Lewis, Spt J. R. Harrigan, Engr G. W. Baldwin; 4.5 m; 3 c, 36 h, 40 m. Janesville (15.481). Janes. St. Ry. Co.—Pr Stephen G. Clarke (1525 N. Halsted St., Chicago), Sec John P. Allgood, Spt Chas. Atwood; 4.5 m; 6 c, 16 h, 2 m.

La Crosse (14.829). La. St. Ry. Co.—Pr E. E. Edwards, Spt T. Daggett, Spt P. Vatter and Geo. F. Smith; 6.5 m, 4-8 c, 40 to 50 lb; 19 c, 82 h, 4 m. Madison (10.325). Mad. St. Ry. Co.—Pr E. W. Hayes, Sec B. W. Jones, Spt & Engr A. H. Knitzer; 2 m, 4 c, 23 lb; 6 c, 30 m. Milwaukee (115.857). Cream City RR. Co. (440 East Water St.)—Pr Winfield Smith, Sec Wm. Dankoheer; 22.5 m, 27, 38 to 52 lb; 40 c (in use), 400 h & m Milwaukee City Ry. Co. (209 West Water St.)—Pr Peter McGeeoch, Sec Geo. O. Wuestorff, Spt Geo. Kemmerlein; 33 m, 45 lb; 88 c, 431 h, 72 m.

West Side St. Ry. Co.—Pr Wm. F. Crocker, Sec Thos. J. Durkin, Spt A. McCaughran, Neehan (4.202). Neehan St. Ry. Co. Oshkosh (15.743). Osh. St. RR. Co.—Pr L. Cluette, Sec C. Y. Hull, Spt L. F. Thompson; 8 m, 27 lb. Racine (16.031). Belle City St. Ry. Co. (716 Park Av.)—Pr Spt Geo. B. Hathaway, Sec J. E. Dodger; 4 m, 4 c, 16 lb; 9 c, 40 h. Waukesha (3.669). Wauk. St. Ry. Co.—Pr J. K. Anderson, Sec T. W. Haight.

CANADA.

ONTARIO.

Bellefonte (9.516). Bellefonte St. Ry. Co.—Pr D. Lockwood, GM & Sec S. A. Lockwood; 2.13 m, 28 lb; 5 c, 14 h. Bradford (3.616). Bradford St. Ry. Co.—Pr D. A. Flack, GM & Sec Chas. H. Flack; 5 m, 3-8 c, 25 lb; 8 c, 20 m. Chatham (7.878). Ch. St. Ry. Co. Cornwall (5.000). Cora. St. Ry. Co.—Pr C. T. Beach (Sandy Hill, N. Y.); 3 m, 30 lb 4 c, 4 stn m.

Hamilton (35.961). Ham. St. Ry. Co. Kingston (14.991). Kingston St. Ry. Co.—Pr Robert J. Carson, Sec & Tr P. R. Sargeant; 4 m, 3-6 c; 30 c, 30 h. London (19.716). London St. Ry. Co.—Pr V. Cronyn, Sec Jas. H. Flock, Spt Henry Thos. Smith; 6 m, 30 lbs; 12 c, 36 h. Niagara Falls (14.943). Niagara Falls & West. Park & Clifton Tramway Co.—Pr John H. Mooney (40 Wall St., New York), Sec & Spt H. Bache; 4.5 m, 30 and 45 lb; 12 c, 40 h.

Ottawa (27.413). Ottawa City Pass. Ry. Co.—Pr Thos. C. Keefer, Sec Jas. D. Fraser; 6 m, 30 lb; 9 c, 40 h. St. Catharines (3.831). St. Catharines, Merrilton & Thorold St. Ry. Co.—Pr & Spt E. A. Sargent, Sec J. E. Freeman; 5.75 m, 30 lb; 5 c, 38 lb. 3 Electric m. (Van Depoele system). St. Thomas (5.367). The St. Thos. St. RR. Co.—Pr Jas. Griffin, Sec Geo. Wegg, Spt Morris A. Sargent; 5 m, 30 lb; 5 c, 9 h. Toronto (3.874). Sarnia St. Ry. Co.—Pr J. F. Lester, Sec & Tr Thos. Symington, Spt Henry W. Mills; 5 m, 32 lb; 2 c, 9 h. Sarnia (8.645). Sarnia St. Ry. Co.—Pr Frank Smith, Sec James Gunn, Spt John J. Franklin; 50 m, 4-10 c, 30 lb; 180 c, 865 h.

Windsor (6.561). Soudewick & Windsor Pass. RR. Co. Windsor Electric St. Ry. Co.—Pr Wm. A. Soomer, Sec A. H. Joseph, Spt W. C. Turner, Engr P. C. Poollig; 1.25 m, 2 c; 1 electric m. (Van Depoele system), engine 15 hp.

QUEBEC.

Montreal (140.747). Mont. St. Ry. Co.—Pr Jesse Joseph, GM & Sec E. Lusher, Spt T. H. Robillard; 30 m, 44 lb; 100 c, 715 h. Quebec (34.486). St. Roch & Quebec (Quebec)—Pr Chas. St. Michel, Sec Tr & Spt Samuel Moore; 3 m, 4-8 c, 45 lb; 9 c, 44 h. St. John St. Ry. Co. (Lim.) (504-506 St. John St.)—Pr Jos. W. Heary, GM & Sec W. W. Martin; 1.35 m, 4-8 c, 35 lb; 4 c, 4 omnibuses, 33 h.

MANITOBA.

Winnipeg (14.000). The Winnipeg St. Ry. Co.—Pr Jas. Austin, Sec & GM Albert W. Austin, Spt A. Young; 5 m, 35 lb; 15 c, 15 sleighs and omnibuses, 100 h.

NEW BRUNSWICK.

St. John (26.127). St. John St. Ry. Co.—Pr John R. Botwell; 7 m, 45 and 60 lb r, 15 c, 65 h. Offices, Room 39 Drexel Building, New York, and St. John, N. B.

NOVA SCOTIA.

Halifax (36.100). Halifax St. Ry. Co. (Lim.)—Pr John Bothwell, Sec & Tr H. B. Helyar, Spt J. C. MacDonald; 7 m, 45 and 60 lb; 15 c, 65 h. Offices, Room 39 Drexel Building, New York, and Halifax, N. S.

# The Laeledge Car Company,

MANUFACTURERS OF ALL KINDS OF

# Street Railway

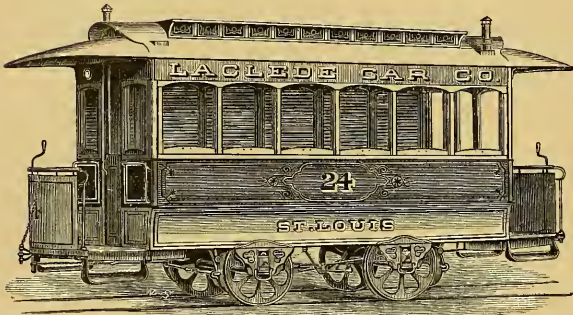
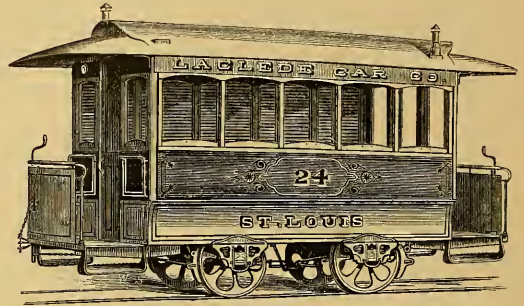

# Cars.

## Street, Cable, or Electric,

Of the latest Improved  
Patterns, all parts being  
interchangeable and easily  
duplicated.

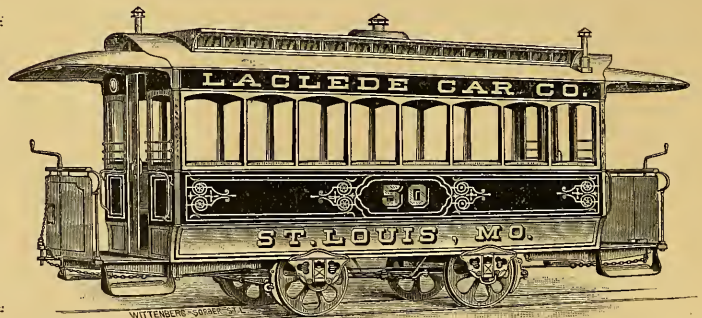

WITTEBERG CAR CO

## ST. LOUIS, MISSOURI.



MEXICO.

Chihuahua (12,000). Chihuahua St. Rly. Co.—GM A. Gonzalez, Jr. Carraoa (4,500). Ferro-Carril Urbano de Carraoa—GM Jose Antonio Cabral; 2 m, 3-10 g.

CENTRAL AMERICA AND WEST INDIES.

CUBA.

Havana (25,000). Havana City Rly.—13 m, 82 c, 5 stm tr. Huelva and Guanabacoa Tramway.—3 m, 10 c, 5 stm tr.

HAYTI.

Port au Prince (35,000). Port au Prince St. Rly. Co.—Pr & Tr C. Lindmann (55 and 67 Beaver st., New York), Spt. H. T. Crain; 4 c, 3-6 g, 20 c (10 pass.).

PORTO RICO.

Aquabella (—). Tramway of the Estate "Casualdad,"—GM Carlos Aleris; 1.35 m, 1-11/2 g, 20 c. Tramway of the Estate "Coloso,"—GM Emilio Yadi; 1.25 m, 1-7/8 g, 30 c.

SAN DOMINGO.

Puerto Plata (—). Muelle Nuevo Tramway.—Owners Jose Sinebra and associates, F. Plos, Stos. Simpson, Spt. Ed. Bugaria; 1.25 m, 4 g, 16 lb; 22 c (pat-form).

SAN SALVADOR.

San Salvador (18,500). San Salvador and Santa Tecla Tramway (built by Government).—Owner F. Camacho, of Guatemala.

SOUTH AMERICA.

ARGENTINE REPUBLIC.

Buenos Ayres (285,000). Anglo-Argentine Tramways Co. (4 Copthall Buildings, London, and at Buenos Ayres).—Local Dir. A. B. Wankly, Sec. Louis Stearn; 27 m, 42 lb; 119 c, 65 p.

BRAZIL.

Bahia (128,929). Companhia de Ferro-Carril Transportes Ultramarinos.—Spt Theodore de Gomes; 20.5 m, 40 lb; 69 c, horses out 8 stm tr; stationary engine for inclined plane, and a hoisting machine 191 feet lift.

CHILE.

Santiago (200,000). Ferro-Carril Urbano de Santiago.—Fr Eduardo Matti, GM Ramiro Sanchez; 20 m (3 m in city of Santiago), 48 lb. Valparaiso (97,737). Ferro-Carril Urbano de Valparaiso.—Sec Guillermo Lawrence, Spt & Engr Eugenio Hamner Carrera; 6 m, 5-6 g, 45 lb; 55 c.

ECUADOR.

Guayaquil (26,000). Guayaquil Tramway.—4 m.

PARAGUAY.

Asuncion (16,000). Tramway de la Ciudad de la Asuncion.—Owners Wm. Woodgate & Co. (Buenos Ayres), GM Jas. N. Horrocks; 1 m, 40 lb; 6 c.

UNITED STATES OF COLUMBIA.

Bogota (100,000). The Bogota City Ry. Co. (Rm 20, No. 1 Broadway, New York)—Pr Geo. H. Slayter (333 Clinton Ave., Brooklyn, N. Y.), Fr & Sec F. W. Allen (1 Broadway, New York), Spt James E. Davies (Bogota, U. S. Columbia); 8 m, 8-3 g; 16 c, 130 m.

URUGUAY.

Montevideo (115,500). Ferro-Carril del Norte (Montevideo to Barra de Santa Lucia).—Tranvia Central (Central Tramway); 11 m. Tranvia Cerreto; 2.5 m. Tranvia del Este; 4.5 m; 86 c. Tranvia Oriental; 5 m. Tranvia de Paysandú.

VENEZUELA.

Caracas (55,688). Caracas Tramway; 3 m. La Guaira (6,768). La Guaira and Magneta Tramway; 1.5 m, 5 g, 30 lb; 2 c.

GREAT BRITAIN AND IRELAND.

ENGLAND AND WALES.

Abercromby (31,436). Acerr. Corporation Tramways.—5.4 m, 4 g; 6 c, 6 stm tr. Aford (4,381). Aford & Suttoon Tramway Co.—7.05 m, 2-3 g, 4 g, 14 trucks, 3 stm tr.

Bath (53,761). Bath Tr. Co.—1.7 m, 4 g; 7 c, 25 h. Birkenhead (83,321). Birkenhead Tramways Co. (Palms Grove, Cloughton, Birkenhead).—Chr. P. Tallender, Sec & GM George Lloyd, Engr Wm. Hopkins, E. E. Birmingham (400,757). Bin. & Aston Tramways Co., Lim. (14 Old Square, Bm.)

Birmingham (400,757). Bin. & Aston Tramways Co., Lim. (14 Old Square, Bm.) Chr. P. Tallender, Sec & GM W. H. Bartley; m m; 7-9 g; 25 c, 23 h, 26 stm tr. Bin. Central Tramways Co., Lim. (Old Market, Bm.).—Chr. T. J. Moore, GM F. J. Nicholson, Sec W. Halden, Engr Joseph Kincald, M. I. C. E., and Edward Pritchard, E. E.; 24.6 m, 3-8 g, 3-11 g; 129 c, 6-11 lb, 57 stm tr.

Bristol (208,475). The Bristol Tramways & Light Railway Co., Lim. (151 Clarendon St., Bm.).—Chr. Wm. Butler, GM (traffic) Chas. Challenger, Sec Geo. White, Engr Joseph Kincald, M. I. C. E.; 18 m; 45 c, 4 buses, 404 h. Burnley (43,349). The Burnley Tramways Co., Lim. (57 Moorgate St., E. C., London).—GM H. Mozley, Sec Edw. Bellamy; 7.01 m, 12 c, 13 stm tr.

Cardiff (10,512). Jwyntyn Tr. Co.—Cardiff (55,378). Cardiff District & Penarth Harbour Tr. Co., Lim. (17 Church St., Cardiff).—Chr. Allan D. Jones, Sec D. Roberts, E. C., London. The Cardiff St. Tramways (Bute Land, Cardiff).—Owned by the Provincial Tramways Co., Ltd., Fr. Poultry, London).—Sec J. B. Glenn, GM W. C. Horley; 4.5 m; 28 c, 11 h.

Cardiff (10,512). Jwyntyn Tr. Co.—Cardiff (55,378). Cardiff District & Penarth Harbour Tr. Co., Lim. (17 Church St., Cardiff).—Chr. Allan D. Jones, Sec D. Roberts, E. C., London. The Cardiff St. Tramways (Bute Land, Cardiff).—Owned by the Provincial Tramways Co., Ltd., Fr. Poultry, London).—Sec J. B. Glenn, GM W. C. Horley; 4.5 m; 28 c, 11 h.

# Wm. Wharton, Jr., & Co.

(INCORPORATED.)

OFFICE AND WORKS,

25th Street and Washington Ave.,

PHILADELPHIA, PA.

Engineers,  
 Founders  
 —AND—  
 Railroad  
 Contractors,

—MANUFACTURERS OF ALL MATERIALS FOR—

STREET RAILWAYS, CABLE AND  
ELECTRICAL RAILWAYS,

## PATENT STEEL GROOVED RAILS

FOR CURVES,

Railway Switches and Frogs of Steel or Iron, Turntables,  
Transfer Tables, Automatic Switches, etc., etc.

All kinds of Steel Street Rails, and the  
Wharton System of Steel Girder Construction.

All kinds of Steel Slot Angles

for Cable Railways.

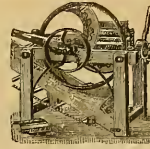

BELLE CITY  
Feed & Ensilage  
CUTTER.

Made in all sizes for both power  
and hand use. Send for illus-  
trated Catalogue and Price Lists.  
File and Ensilage Treatise FREE  
to all who mention this Paper.  
Belle City Mfg. Co., Racine, Wis.



CHEAPEST HOUSE IN THE WORLD  
FOR ALL KINDS OF

## Engineers' Instruments

— FOR THE —

Survey of Cable and other Street Railways.

Transits, Levels, Rods, Chains, Tapes, Plumb-  
bobs, Etc., a Specialty.

Aloe's New Model Transit,

*Especially adapted for Street Railway Work.*

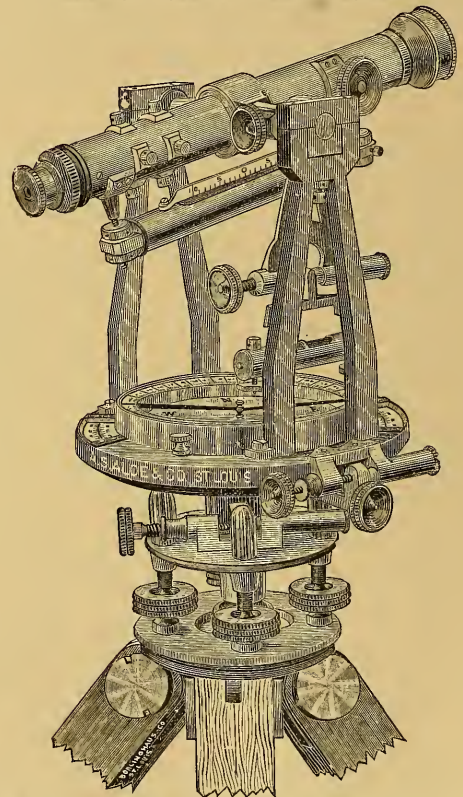

We will guarantee this instrument first-class in every  
respect. Send for illustrated catalogue and price list. We  
will make special prices to roads dealing direct.

Also, Blue Print Paper. Mathematical and Drawing  
Instruments, Drawing Paper, Boards, Pins, Etc. Paints,  
Brushes, Palettes, Etc. Curves, Pencils, India Ink, Rules,  
Ellipses, Engineers' Alphabets, Protractors, Compasses,  
Sextants, and everything for use either in the field or  
draughting room.

**A. S. ALOE & CO.,**  
300 North 4th Street, — — ST. LOUIS, MO.





Patents.

The following list of recent Patents relating to Inter-mural traffic is specially reported for THE STREET RAILWAY GAZETTE by Wm. H. Henderson, Solicitor of American and Foreign Patents, 925 F Street, Washington, D. C. A copy of any of the following will be furnished by him for 25 cents.

- 372,792. Splicing traction cables, P. S. Fransze—Chicago, Ill.
- 372,749. Underground cable car conduit—L. D. Hagerty, Baltimore, Md.
- 372,816. Track cleaning attachment for street cars, etc.,—C. I. Peper & Co., Sobinski, St. Louis, Mo.
- 372,866 and 372,867. Cable railway—C. Peper, St. Louis, Mo.
- 372,930. Cable lifter for cable railway—J. H. Robertson, New York, N. Y.
- 372,703. Permanent way for railways—I. A. Perro, Wilmington, Del.
- 373,189. Cable grip—L. D. Libbey, Wyandotte, Kan.

- 373,358. Car mover—L. B. Gifford, Loledo, Ohio.
- 373,208. Car starter—H. P. Titus, Lisbon, N. H.
- 373,149. Automatically adjustable railway crossing—T. McGrath, Toledo, O.
- 373,046. Electrical railway—B. Bidwell, Philadelphia, Pa.
- 373,106. Cable railway grip—H. R. Taylor, Oakland, Cal.
- 373,052. Railway rail joint—H. D. Cone, Stockbridge, Mass.
- 393,294. Railway shunt—F. W. Kalbfleisch, Brooklyn, N. Y.
- 373,624. Car brake and starter—A. M. Vereker and S. M. Ceates, Dublin, Ireland.
- 373,639. Motor car—C. M. and J. A. Brill, Philadelphia, Pa.
- 373,437. Car starter—D. L. Brown, Franklin, Mass.
- 373,605. Elevated railway—D. D. Read, Boston, Mass.
- 374,084. Car brake and starter—E. J. F. Quirin, Tioga Centre, N. Y.

(Patents continued on page 27.)

—\*—BUY DIRECT OF THE MANUFACTURER.—\*—

# MULE BELLS, SEND CABLE PRICES, GONGS,

BEST AND CHEAPEST IN THE MARKET. SAMPLE MULE BELL FOR 20 CENTS.

VAN DUZEN & TIFT, CINCINNATI, OHIO.

EXTRACT FROM SALES BOOK OF

## Augustus Day's Improved Street Railway Track Cleaner.

22 PARK PLACE, DETROIT, MICH.

### RECORD OF SALES.

Albany Railway, ALBANY, N. Y.			Chicago City Railway, CHICAGO, ILL.			Detroit City Railway, DETROIT, MICH.			New Haven & W. H. R. R., NEW HAVEN, CONN.			Rochester City & Brighton R. R., ROCHESTER, N. Y.			Merrimack Valley H. R. R., LAWRENCE, MASS.				
Month.	Year.	No. Pair.	Month.	Year.	No. Pair.	Month.	Year.	No. Pair.	Month.	Year.	No. Pair.	Month.	Year.	No. Pair.	Month.	Year.	No. Pair.		
Jan.	1874	10	Feb.	1871	30	Dec.	1870	20	Feb.	1874	1	Jan.	1871	1	Oct.	1873	4		
Oct.	1874	7	Oct.	1871	20	Jan.	1871	4	Feb.	1874	1	Jan.	1871	1	Feb.	1878	1		
Dec.	1875	3	Jan.	1877	16	Oct.	1871	6	Feb.	1874	3	Jan.	1873	17	Oct.	1878	3		
Nov.	1878	2	Nov.	1877	50	Oct.	1873	6	Dec.	1875	2	Jan.	1874	4	Oct.	1879	10		
Nov.	1879	6	Oct.	1878	20	Oct.	1875	8	Nov.	1878	2	Oct.	1878	6	Sept.	1880	3		
Nov.	1882	10	Jan.	1879	10	Nov.	1880	8	Sept.	1882	2	Oct.	1879	4	Oct.	1881	4		
Oct.	1884	16	Aug.	1879	30	Nov.	1881	8	Dec.	1885	4	Sept.	1880	6	Oct.	1881	4		
Nov.	1884	7	Sept.	1880	60	Nov.	1882	24	Oct.	1882	2	Oct.	1881	4	Oct.	1882	5		
Aug.	1885	6	Dec.	1880	4	Oct.	1883	12	Oct.	1883	15	Oct.	1882	15	Oct.	1883	15		
Dec.	1885	10	Sept.	1884	70	Dec.	1885	31	Oct.	1884	12	Oct.	1884	12	Oct.	1884	12		
Total	77	Jan.	1885	40	Jan.	1886	9	Total	20	Oct.	1885	20	Oct.	1885	20	Oct.	1885	20	
		Dec.	1885	30	Total	154													
Lynn & Boston R. R., BOSTON, MASS.			Bridgeport H. R. Y., BRIDGEPORT, CONN.			Cream City Railway, MILWAUKEE, WIS.			Central City R'y., SRAUGUSE, N. Y.			Pullman Palace Car Co for City Pass. Ry., CHICAGO, ILL.			Adams St. R'y., TOLEDO, O.				
Month.	Year.	No. Pair.	Month.	Year.	No. Pair.	Month.	Year.	No. Pair.	Month.	Year.	No. Pair.	Month.	Year.	No. Pair.	Month.	Year.	No. Pair.		
Feb.	1872	4	Nov.	1874	4	Dec.	1874	7	Nov.	1875	1	Oct.	1874	3	Oct.	1874	3		
Feb.	1874	6	Nov.	1875	4	Dec.	1875	5	Dec.	1878	1	Nov.	1875	6	Nov.	1875	6		
Nov.	1874	30	Nov.	1879	4	Dec.	1877	3	Dec.	1878	1	Nov.	1879	1	Nov.	1879	1		
Dec.	1875	4	Nov.	1881	6	Oct.	1878	2	Oct.	1881	2	Nov.	1884	2	Nov.	1884	2		
Dec.	1878	14	Oct.	1883	8	Oct.	1878	5	Oct.	1881	4	Nov.	1884	2	Nov.	1884	2		
Dec.	1879	10	Dec.	1884	6	Nov.	1879	5	Total	11	Nov.	1884	2	Nov.	1884	2			
Jan.	1880	10	Dec.	1885	6	Sept.	1880	4	Total	11	Oct.	1885	50	Nov.	1884	2			
Total	78	Oct.	1885	6	Oct.	1882	8												
Fort Wayne & Elmwood Railway, DETROIT, MICH.			Fifth Ward Railway, SRAUGUSE, N. Y.			Milwaukee City R'y., MILWAUKEE, WIS.			Toledo St. Railway, TOLEDO, OHIO.			Portland Trans. St. R. R., PORTLAND, OREGON.			Naumkeag St. R'y., SALEM, MASS.				
Month.	Year.	No. Pa.	Month.	Year.	No. Pair.	Month.	Year.	No. Pair.	Month.	Year.	No. Pair.	Month.	Year.	No. Pair.	Month.	Year.	No. Pair.		
Feb.	1870	12	Oct.	1874	5	Dec.	1874	7	Nov.	1879	9	Nov.	1879	9	Nov.	1874	18		
Dec.	1871	4	Nov.	1875	5	Nov.	1879	5	Oct.	1882	2	Dec.	1875	2	Oct.	1878	16		
Dec.	1873	2	Oct.	1878	5	Oct.	1882	4	Nov.	1882	1	Nov.	1884	4	Oct.	1878	16		
Nov.	1879	2	Sept.	1883	2	Nov.	1884	2	Nov.	1882	1	Sept.	1885	4	Sept.	1884	16		
Oct.	1881	2	Nov.	1884	4	Oct.	1882	4	Oct.	1882	2	Oct.	1885	5	Sept.	1885	13		
Nov.	1881	2	Nov.	1885	2	Nov.	1884	2	Total	12	Oct.	1885	5	Sept.	1885	13			
Nov.	1885	2	Total	40	Total	39	Total	12	Total	9	Total	9	Oct.	1885	13				
Total	50	Total	16	Total	50	Total	12	Total	9	Total	9	Total	69	Oct.	1885	13			
Lowell Horse R'y., LOWELL, MASS.			Louisville City R'y., LOUISVILLE, KY.			Street R'y. of Grand Rapids, Mich.			Lowell Horse R'y., LOWELL, MASS.			Louisville City R'y., LOUISVILLE, KY.							
Month.	Year.	No. Pair.	Month.	Year.	No. Pair.	Month.	Year.	No. Pair.	Month.	Year.	No. Pair.	Month.	Year.	No. Pair.					
Nov.	1874	12	Oct.	1874	5	Nov.	1876	2	Nov.	1874	12	Nov.	1874	12					
Dec.	1875	2	Oct.	1878	5	Jan.	1879	2	Dec.	1875	2	Nov.	1875	2					
Jan.	1877	2	Sept.	1883	2	Nov.	1880	10	Jan.	1877	2	Oct.	1879	10					
Oct.	1879	2	Oct.	1883	4	Jan.	1884	8	Oct.	1878	1	Oct.	1882	12					
Nov.	1881	2	Nov.	1885	2	Dec.	1885	5	Oct.	1879	2	Nov.	1883	10					
Nov.	1885	2	Total	16	Total	50	Total	33	Oct.	1879	2	Nov.	1883	10					
Total	50	Total	16	Total	50	Total	33	Total	27	Total	53								



**Leyden** (42,000). Leyden Tramway Co. (office, London).—*Dir Fryman*, #Gravenhage; 106, 10 h.  
**Niehscheur Tramway Co.** of Utrecht; *Dir W. J. Visser*; 7,327 m; 14 c, 45 h.  
**Hollands (152,517)**. Rotterdam, Hilversberg, Scheideind Tramways Co.—*Dir H. P. Schomans*; 2,650 m, 8 c, 20 h.  
**Rotterdam Tramway Co.**—*Dir H. P. Ginchart*; 31,440 m, 40 c, 206 h.  
**Zeebe-Drieherg (Oosterschelde) Tramway**—*W. J. Visser* (Utrecht); 3 c, 5h.  
**Utrecht** (69,657). Netherlandus Tramway Co. of Utrecht.—*Dir S. Hamelink*; 50.3 m; 24 c, 10 h.

**SWITZERLAND.**

**Basle** (62,000). Basle Tramway Co.—*Tramway J. Sattelin*; 8c, 60 h.  
**Geneva** (45,783). Comp. Gen. de Swis Tramways; *Engr T. Laval*; 12,988 m; 51 c, 162 h, 1 stn nr.  
**Wetzstein-Hel-Weidau** (12,000). Tramways Co.—*Engr T. Laval*; 2,949 m; 7 c, 15 h.  
**Zurich** (21,199). Zurich St. Ry. Stokk Co.—*GM Th. Roth*; 7,415 m; 30 c, 104 h.

**BELGIUM.**

**Anvers** (—). National Tramways of Anvers.—*Dir Vander Meeren*.  
 \* Tramways of South Anvers.—*Dir Hallers*.  
**Brussels** (281,782). Tramways of Brussels.—*Dir H. G. Mieheli*, *Engr F. Nonnenberg*, Chief of technical service.  
 \* General Company of Railways.—*Dir de Baeker*.  
 \* Company of Secondary Ry.—*Dir A. Poepelt*, *Engr A. Speo*.

**FRANCE.**

**Helms** (81,228). Tramways of Helms.—*Dir E. Thomms*.  
**Rouen** (104,902). Rouen Tramways Co. (56 Rue Beufroisne, Rouen).—38 c, 155 h, 7,116 shares (500 francs each) of the Compagnie des Tramways de Rouen are held by the Tramways Company of France, Limited (11 Old Jury Chambers, E. C., London).

**ITALY.**

**Brescia** (38,000). Tramways of Brescia.—*Engr A. Spee* (Brussels).  
**Milan** (295,513). The Lombardy Road Railway Co., Ltd. (Capital Building, E. C., London, Eng., and 42 Via Carlo Farini, Milan); 75 km; 45c, 54 wagons.

**DENMARK.**

**Copenhagen** (273,323). Norebroens Sporveisselskab (Norebrogade 196, N.).—*Pr C. V. Wolfhagen*, Sec. C. Jacobsen, *Spt C. Larsen*; 3,455 metres (=3780 yards), 4-11 c, 65% lbs; 25 c, 145 h.  
**Kjobenhavn Sporvejs Selskab**—*Engr M. Olsen*; 14,000 meters; 54 c, 300 h.  
 Forstaderens Sporveisselskab.

**NORWAY.**

**Christiania** (124,155). Tramways of Christiania.—*Dir M. Vogt*.

**RUSSIA.**

**Kharhoff** (—). The Tramways of Kharhoff.—*W. Hammeirath*, Sec of Administration, Brussels.  
**Moscow** (—). The Tramways of Moscow and Russia.—*See Mr. Hammeirath*.  
**Odessa** (—). Tramways of Odessa.—*Engr M. Boursin*, Brussels.  
**Warsaw** (—).—*Dir de Baeker*, Brussels.

**SPAIN.**

**Madrid** (397,861). Madrid St. Tramways.—Owned by the Tramways Union Co. m., London.—6.5 m; 55 c, 297 h.

**ROUMANIA.**

**Bucharest** (221,805). Bucharest Tramways.—Owned by the Tramways Union Co., Ltd., London.—*Sec J. E. Walker*, *GM G. W. Webb*; 10.5 m; 42 c, 169 h.

**INDIA.**

**Calcutta** (871,504). The Calcutta Tramways Co., Ltd (11 Abchurch Lane, E. C., London, Eng.—*Chr E. C. Morgan*, *Sec Chas. Akers*, *Engr Geo. Hopkins*, C. E.; *Managing agent in Calcutta J. R. Maples*; 19.5 m, 150 c, 662 h, 9 stn nr.

**AUSTRALIA.**

**NEW SOUTH WALES.**

**Melbourne** (280,836). The Melbourne Tr. Co.—*Engr Geo. Dumcans*; 34 m (10 m cable road in operation).  
**Sydney** (222 133). The Sydney Cable Tr. Co.—3.5 m (cable).

**Horse, Cable, Electric and other Railways**

In a communication dated Tacoma, W. T., Aug. 2d, 1887, Mr. C. O. Bean, City Engineer of Tacoma, sums up the merits and demerits of the various street railway systems in vogue in America. The document is addressed to Willard Bennett, Deer Lodge, Mon., who, it appears, desired to know which is the best plan for intermural passenger transportation. The paper occupies nearly six columns in the *Western Electrician*. But the pith thereof is comprised in the following paragraphs:

"There probably has never been a time in the history of street railways when there was so much careful investigation or so much keen interest manifested on the part of owners and officers of roads, and others, as at present. I first examined the horse-car system of Portland, Oregon; there I found them complaining of six and seven per cent. grades, and eagerly watching the development of the reported cheap cable systems and electric systems. They seemed eager to do away with horses. The next examined was the so-called noiseless exhaust steam motors used in Minneapolis. There the grades were very light and the traffic quite heavy. People in the suburbs were well pleased with it, because of it being so much more rapid than the horse-car; but in the city proper, and particularly in the business portions, there is decidedly strong opposition to its use.

"The next place visited was Chicago, where a short line, a few hundred feet in length, of the Rasmussen cable is on exhibition. The Rasmussen system is far from perfected and is run on far too small a scale to enable one to judge of

what it will do on a large scale. The mechanical construction of the system is very faulty, and its owners display too much uncertainty to warrant its adoption. There was much talk of its adoption by several cities, but so far as I can learn it is nowhere in use.\* I also examined the California system of cable used on State Street in Chicago. It is working successfully. It is useless, however, to attempt its operation except in places where the traffic is very heavy, since its cost is about one hundred thousand dollars per mile. In such places as St. Paul, Chicago, St. Louis, Kansas City, San Francisco, etc., where the traffic is heavy, it is used with marked success and satisfaction.

"In Detroit, Michigan, I carefully examined the VanDepeole Electric Railway, on what is called the Dix road. They have a poorly ballasted roadbed, and their motors are not of the more recently approved pattern. They haul their trains, however, without trouble, and the road is giving as good satisfaction as could be expected under the circumstances.

"The next examined was the Fisher system of electric railway in Detroit. I found this system in an experimental state. On this road the conductor is in a conduit between the rails. A conduit of this type can never be used with safety and success in the streets of a city, though it may do in the country. In Windsor, Ontario, the road is a common wooden stringer with a strap iron on the top. The road is working successfully. The owners are so well pleased that they have ordered T rail for their road.

"The VanDepeole people said nothing to me about the Port Huron road, in consequence of which my suspicions were awakened, and I concluded to go there. A large part of this road has T rail of only sixteen pounds weight to the yard. I met the secretary, from whom I learned that his company at first experienced considerable trouble through the fault of the man sent to fit up the cars. At one time they were considerably disgusted, and thought of discarding the electric motors entirely. Now they are well pleased. They claim their expenses are one-third less than with horses and far more satisfactory. On reaching the suburbs they run their cars from ten to twenty miles an hour without trouble.

"I next visited Pittsburg, Penn., where several electric railway companies had roads on paper. I found them preparing to use electric motors, and in one instance on grades as steep as fourteen per cent. The road in Appleton, Wis., and one in Scranton, Pa., are two roads to which nearly all if not all electric railway companies, as well as electricians, point with unconcealed and becoming pride. They have good road-beds, beautiful cars, good motors, and are well managed. Mr. Sturges, the president of the Scranton company, told me that before adopting the electric system he had seen the various electric systems in Europe and had carefully examined the systems in America. He claims it is cheaper and far more satisfactory than horse power. Before adopting the system the directors were almost unanimously opposed to the use of electricity, but yielded to Mr. Sturges. They are now unanimous in its favor. The directors are so thoroughly convinced of the practicability of the system that they were building when I was there a generating plant that was estimated to cost \$25,000. I met a gentleman who had personally examined the Appleton road, not once alone, but several times during both summer and winter weather. Its success has probably been more marked than that of any other electric road in the world. In Appleton a snow plow was attached to the car when necessary, and the motor cleared the snow from the track even on the worst grades. It exceeded the most sanguine expectations of its warmest advocates.

"Still there were two questions left, viz.: Is there a better system than the VanDepeole? Will the motor answer for our heavy grades?

"I next went to Baltimore to see the Daft system at work. I can say that I am still almost surprised at what I

\* A contract has since been closed to build a Rasmussen cable system on the Newark and Irvington street railway, New Jersey, as stated in the September GAZETTE.

saw there. A very light motor car, a regular rattletrap of a thing in fact, carried the motor. The wheels of the motor were out of true and pounded on the rails so much as to render it exceedingly difficult for me to ride, even when hanging on with both hands. Yet this little motor car, loaded only with the motor and its attendant, hauled a full load of passengers easily over a road noted for sharp curves and heavy grades. A careful examination of the electric road in Baltimore convinced me that far steeper grades can be successfully ascended with the electric motor than have heretofore been attempted or than can be overcome by any other system except the cable.

"I next visited the Baltimore Locomotive Works,\* in Philadelphia, concerning steam motors, and was the more convinced that they will not answer for heavy grades within city limits.

"I next called at the offices in New York of all the principal electric railway companies. Unfortunately none but the Daft had at that time any lines equipped, though it was expected to soon commence equipping important lines with the Sprague system, the St. Julien [Mr. Julien is not yet a saint], and the Knight Bently [Bently-Knight]. I examined their several stationary motors where they were convenient, and carefully inspected drawings and plans of the various systems.

"My next visit was to Lima, Ohio, on July 4th, where the VanDepoele system worked beautifully.

"I next examined the cable roads of St. Louis and then of Kansas City. They are all of the California type. In Kansas City I found the Henry system of electric railway. Here again are six per cent. grades. The electric motor was doing its work well. The makers have not yet properly proportioned the various parts of their apparatus, and are yet really experimenting, remodeling and improving.

"I next examined the Daft electric motor in Los Angeles. It is still doing good work and is giving general satisfaction. The difficulties here are not so great as in Baltimore, and hence the success of the Los Angeles road is not so surprising. The next examined were the steam and cable roads of San Francisco and Oakland.

"I have omitted stating that in Brooklyn there is on trial a new kind of cable. It is composed of two cables about three-fourths of an inch apart with short bars across about every eight to twelve inches like a rope ladder. Thus far the builders have attempted to run on straight lines only. The system is in an experimental state as yet. It will cost more than the Rasmussen system.

"You will understand from the foregoing that I have examined the steam motor systems, three cable systems, four electric systems in use and others on paper, besides horse car lines too numerous to mention. I have attempted, at least, to judge without prejudice of the merits of the various systems, and in advising you which system to adopt, have taken into consideration the peculiar conditions under which a system of street railway will have to be operated in Butte."

Then follows the advice, embracing a classified recapitulation of the foregoing statements, with costs compared and a specification of local requirements. In conclusion the writer says:

"As to the choice of motors, I suggest the following considerations: They are all reaching a greatly improved state. The Daft, the Fisher, the Sprague, the Henry, are all good, but at present I have more confidence in the VanDepoele, for the reason that it is in use on more roads than all others combined, thus enabling VanDepoele to study the motor under a great variety of conditions, and to learn wherein improvements can be made. I feel further influenced by the fact that several of the most careful railway managers, after carefully examining the other motors, chose the VanDepoele. For a continual successful use of the electric motor it is absolutely necessary that it should be close under the eye of the operator. This is a fact that VanDepoele alone seems to fully appreciate. The brush on the motor should be free from dust."

\* Probably the Baldwin Locomotive Works are meant.

## The Silvester Compressed Air Motor.

Jay Gould has many relations and friends. *Res amicos invenit*. The famous millionaire has a nephew in St. Louis, to whom Mr. Henry Silvester went some time ago to explain an invention he had, which would revolutionize the means of operating our railroads and street railways:—"it beats electricity; it is *practically* perpetual motion". There was an opportunity for Jay Gould to increase his fame tenfold at one bound. But the nephew advised the inventor to see the most famous railway-car builder, George M. Pullman, for unexplained reasons. Inventor Silvester subsequently came to Chicago; called repeatedly at the Pullman building, but failed to obtain an interview. Ultimately he wrote to Jay Gould—but he received no manner of reply. And now, as a *dernier ressort*, Mr. Silvester condescends to submit a condensed description of his air motor to the readers of the STREET RAILWAY GAZETTE; and we understand he is willing to negotiate with any man of lesser note than Pullman or Gould, who may be disposed to furnish the needful for experimental purposes.

We feel justified in giving space to this brief description of the invention, inasmuch as Mr. Silvester is the inventor of a patent tire used extensively by C. B. Clarke, of St. Louis, and other carriage builders. And, moreover, a model of the Silvester street pavement is now under the serious consideration of the Chicago city council. Therefore his air motor may rightly claim our attention.

The Silvester patent compressed air motor "is an invention for propelling all kinds of rolling stock, and consists of an air pump of peculiar construction, placed between the body and gear of the vehicle, the upward and downward motion, or the vibration of which operates the pump, which is provided with a number of chambers; and certain motions of the vehicle press the air from one chamber to the next smaller one, and so on through a graduated series of chambers, while the reverse motions create vacuums therein ready to receive further supplies of air through an automatic valve from outside the pump. The compressed air passes from one chamber to another through valves, being compressed tighter as it goes, until it reaches a tank, or receptacle, which is made to contain air at a pressure of two hundred pounds to the square inch. Each chamber of the pump is provided with a spring which is placed between two disks, each spring being of a different strength. The first chamber has a light spring, the second a little stronger, and so on, this being so arranged that all the air can be forced out of the first chamber before the spring in the second one will give way, and so the chambers close one after another. In this way all the air which enters the pump is secured,—all going one way, none allowed to escape or expand after it enters the first chamber of the pump. As many of these pumps as may be required can be put under any vehicle or car.

"The chambers of the pump being telescoped into each other, not much room is taken up. An ordinary street car may be propelled by means of a double crank axle and two oscillating cylinders with proper attachments. A car thus equipped can be handled like a locomotive; and the same air which is used for propelling the car will form a powerful brake for the same. A train of cars can be propelled as easy as one, each car being provided with pumps, and each pump contributing its share of the compressed air which is conveyed through pipes to the tank (or the boiler of a locomotive); and thus steam will be abandoned."

## Clay's Portable Register.

The eyes of one Philip B. Clay fell upon the STREET RAILWAY GAZETTE at the Chicago Public Library; and in turning over the October number he no sooner discovered Mr. Bonnell's paper on "The Best System of Checking Conductor's Returns," and the discussion thereon, than his inventive faculty was quickened, and a dormant idea came to the front, although he is not in any way connected with the management of street railways. As soon as he may secure a patent he promises to furnish us with a full descrip-



tion of a portable register for conductors, the use of which will absolutely prevent dishonesty. That is just what is wanted, and we should have been glad of full particulars; but all we could get out of the inventor, at present, is that "this register is no more like any other register than a horse is like a man. \* \* \* The conductor can take a crowded car, and have both hands at liberty to receive fares as rapidly as he pleases, while each fare is registered promptly (even before change is returned) right before the passengers' eyes, and it would be impossible to work a dummy." If this should be accomplished, Clay's register will be the "latest novelty" for some time.

### The Brussels Electric Tramway.

A paper on the electric tramway of Brussels, has been contributed by A. Bandsept to the Societe des Anciens Elèves des Ecoles Nationales d'Arts et Metiers. The cars are propelled by motors under the floor, and a current is supplied by Julien accumulators inserted under the seats from the sides, and not from the end of the car as in Prof. Reckenzaun's arrangement. Thirty miles are run without changing the batteries. The total weight of the car, filled with passengers, is six tons; the weight of the battery being thirty cwt. The field magnets are compound wound, so as to increase the torque on steep gradients. There is a double commutator, the sections of the one being connected with those sections of the other which are diametrically opposite, so as to bring the negative and positive brushes side by side, and not on opposite sides of the commutator, as generally arranged.

### Baldwin Locomotive Works.

Messrs. Burnham, Parry, Williams & Co. extended a courteous invitation to the delegates at the recent Street Railway Convention to visit the famous Baldwin Locomotive Works, Philadelphia. Several availed themselves of the opportunity. These works possess a special interest to street railway men, from the fact that they have taken the lead in designing and constructing steam cars and motors for street railway service. Attention was first given to this subject by the Baldwin works in 1875, and designs were then made for a street car, to be propelled by steam, and subsequently for a separate motor to draw one or more cars. The first steam car constructed was named the "Baldwin," and did service for six months continuously on the Market street railway of Philadelphia during the period of the Centennial Exposition in 1876. The car ran continuously and acceptably, without losing a trip, or giving any trouble. This experiment was followed by the construction of a number of steam street cars for railways in Brooklyn. It soon became evident, however, that the best system for steam propulsion on street railways was a separate motor to draw one or more cars. The advantages of this method are that the machinery and the engineer are entirely separated from the passengers, and that the cars, being coupled to the motor, ride more steadily and with less rocking and plunging than if drawn by horses or propelled by machinery attached to the car itself. Separate motors were constructed for several lines in the United States and Cuba, and this system has now become thoroughly established. Important improvements have been made from time to time, until at this time the Baldwin Locomotive Works are supplying a motor built to the highest standard as to material and workmanship, and with special devices to prevent the show of steam and to muffle the noise of the exhaust. The demand for these machines have steadily increased, and at this time the manufacture of street railway steam motors is no longer an experiment, but an established fact. They are in use on a large number of lines in the United States and elsewhere. During the time of the session of the association, the Baldwin Locomotive Works had under construction eighteen motors for the following lines: Highland Belt Railway Co., Birmingham, Ala.; Chickasaw Land Co., Memphis, Tenn.; West Side Circle Railway Co., Topeka, Kansas; Rome Land Co., Rome, Ga.; Tokio Tramways, Japan; Grand Trunk Rail-

way Co., Canada; Knoxville Real Estate Co., Knoxville, Tenn.; Overland Railway Co., Nashville, Tenn.; Tuscaloosa Coal, Iron & Land Co., Tuscaloosa, Ala.; Urbano Railway, Havana, Cuba; and the Topeka Rapid Transit Railway Co., Topeka, Kansas.

In the city of Sydney, New South Wales, no less than 82 motors constructed by the Baldwin Locomotive Works are in service, and have all been supplied since 1879. An official of the New South Wales Railway department, in a recent letter, gives the following testimony (unsolicited we are informed) as to the efficiency of the Baldwin motors on their lines: "The tramway motors supplied by your firm continue to give me entire satisfaction. We have tried no less than four different types of motors from England against yours, and the one with the greatest support and recommendations has been packed up and sent back again to England. The twelve motors to my order in '83 with hollow crank pins are the best we ever had; three of them have the original pins in them now."

The practice of the Works at this time includes motors varying in weight from 15,000 lbs. to 55,000 lbs. The plans vary from four-wheeled machines to four driving wheels with pony truck, and four driving wheels with a truck at each end for the larger and heavier classes.

ELECTRICAL storage batteries have attracted attention only within the past seven years, but the discovery of the principle is as old as the century, Gautherot having first noticed in 1801 that platinum or silver wires gave off a current after being disconnected from a voltaic battery with which they had been used for decomposing saline water. The first secondary cell of Plante was made in 1860.

OTTUMWA'S (Iowa) street railway franchises, with tracks and equipment, etc., are for sale, as appears from notice in another column.

## THE Brooklyn Railway Supply Co.,

37, 39 & 44 WALWORTH STREET,

BROOKLYN, NEW YORK.

## Street Railway Supplies.

### SPECIALTIES:

SNOW SWEEPERS, SNOW PLOWS, SAND CARS and SALT CARS  
OF OUR OWN MANUFACTURE.

RATTAN FOR REFILLING BROOMS.

Track Tools, Rammers, Manis, Claw-Bars, Crow-Bars, Improved Bending  
Machines, Steel Shovels, Picks, etc.

—AGENTS FOR—

Carpenter's Patent Turntables, Best, Simplest, Cheapest  
in the world.

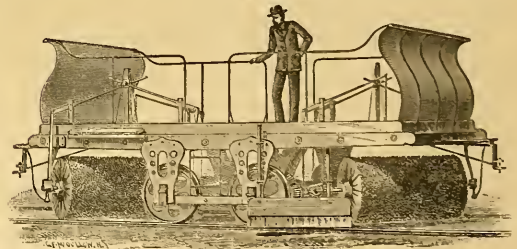

Agents for the New England, Eastern and Southern States, for the

**BOSS AND WALKAWAY SNOW SCRAPERS.**

Cheapest Practical Snow Plows in the world.

# INDEX TO ADVERTISERS

CORRECTED MONTHLY.

## AMBULANCE CARS (For Horses).

**BROOKLYN RAILWAY SUPPLY CO.** (The), 44 Walworth st., Brooklyn, N. Y.

## AXLES.

**ANDREWS, FRANK H.**, 545 W. 33rd st., New York (vide Brakes).

**BALTIMORE CAR WHEEL CO.** (The), Fulton Junction, Baltimore, Md., U. S. A. (Agents—W. S. Greengrove & Co., St. Louis; W. S. Greengrove & Co., London, England).

**BEMIS CAR BOX CO.**, Springfield, Mass.

**BOWLER & CO.**, Cleveland, Ohio.

**BRILL (J. G.) CO.**, Philadelphia.

**BROWNELL & WIGHT CAR CO.**, 2300 Broadway, St. Louis, Mo.

**Cambria Iron Co.**, 218 S. Fourth st., Philadelphia; Cambria at Johnston, Pa. (Branches—No. 18 Wall st., New York; Montauk Block, Chicago, Ill.)

**Carnegie, Phlips & Co.**, Limited, 48 Fifth ave., Pittsburgh, Pa.

**Dederick, Z. P.**, Sherman, Texas.

**Fonte, Otto A.**, Cleveland, O.

**FULTON FOUNDRY** (S. M. Carpenter, proprietor), 202 Marvin st., Cleveland, O. (Agent—Thos. C. White, 107 S. 8th st., St. Louis, Mo.)

**Griffin Wheel & Foundry Co.**, Robey st. and Blue Island ave., Chicago, Ill., and Buffalo, N. Y.

**Howard, Childs & Co.**, Hamilton Building (rooms 607 and 608) Pittsburgh, Pa.

**Laclede Car Co.**, 4500 N. Second st., St. Louis, Mo.

**LEWIS & FOWLER MANUFACTURING CO.** (The), 27 to 35 Walworth st., Brooklyn, N. Y.

**Meyersburg, O. W.**, & Co., 204 N. 30th st., St. Louis, Mo.

**Branch—Phenix Bldg., Chicago, Ill.**

**Pennsylvania Steel Co.**, 308 S. 4th st., Philadelphia. (Works at Steelton, Dauphin Co., Pa.)

**PUGH & RUSSELL**, Stewart Bldg., New York; Phenix Bldg., Chicago, Ill.

**STEPHENSON (JOHN) COMPANY**, Lim., 47 E. 27th st., New York. (Branch—Phenix Bldg., Chicago, Ill.)

**STREET RAILWAY SUPPLY CO.**, Cleveland, Ohio.

**WHITNEY, A., & SONS**, Philadelphia, Pa.

## BARBED WIRE.

**Cambria Iron Co.**, 218 S. 4th st., Philadelphia (vide Axles).

## BEARINGS.

**ADAMS & WESTLAKE CO.** (The), 110 Ontario st., Chicago, Ill.; Birmingham, New York.

**Ajax Metal Co.** (The), 2040 N. Tenth st., Philadelphia.

**American Bronze Works**, 46 Columbus st., Cleveland, O.

**ANDREWS, FRANK H.**, 545 W. 33rd st., New York (vide Brakes).

**BALTIMORE CAR WHEEL CO.** (The), Baltimore, Md. (vide Axles).

**Barrett Mfg. Co.**, 8 Oliver st., Boston.

**BEMIS CAR BOX CO.**, Springfield, Mass.

**BRILL (J. G.) CO.**, Philadelphia.

**BROWNELL & WIGHT CAR CO.**, 2300 Broadway, St. Louis, Mo.

**Castle Manufacturing Co.**, 69 Wall st., New York.

**Danausac Bronze Co.**, Pittsburgh, Pa.

**Dederick, Z. P.**, Sherman, Texas.

**Fonte, Otto A.**, Cleveland, O.

**FULTON FOUNDRY**, Cleveland, O. (vide Axles).

**Greely, The E. S. & Co.**, 5 and 7 Dey st., New York.

**Keystone Smelting Co.** (The), Limited, 33d st., Pittsburgh, Pa.

**Laclede Car Co.**, 4500 N. Second st., St. Louis, Mo.

**LEWIS & FOWLER MANUFACTURING CO.** (The), 27 to 35 Walworth st., Brooklyn, N. Y.

**Martin, Rufus & Co.**, 13 Park Row, New York.

**Menely, Geo. L.**, & Co., West Troy, N. Y. (Branch—Atlanta, Ga.)

**Meyersburg, O. W.**, & Co., 214 N. 3d st., St. Louis, Mo. (Branch—Phenix Bldg., Chicago, Ill.)

**Miller, Chas. B.**, 310 E. 14th st., New York.

**Phenix Brothers & Co.** (The), Limited, 512 Arch st., Philadelphia.

**Post & Company**, Cincinnati, Ohio.

**PUGH & RUSSELL**, Stewart Bldg., New York; Phenix Bldg., Chicago, Ill.

**STEPHENSON (JOHN) COMPANY**, Lim., 47 E. 27th st., New York. (Branch—Phenix Bldg., Chicago, Ill.)

**Stewart & Mattson Manufacturing Co.** (The), 2042 N. 10th st., Philadelphia.

**STREET RAILWAY SUPPLY CO.**, Cleveland, Ohio.

**Thayer, F. W.**, & Co., 428 Broad st., Milwaukee, Wis.

**Tubal Smelting Works**, 760 S. Fowler st., Philadelphia.

**Tyler Bros.**, 8 Oliver st., Boston.

**White, Edward C.**, 531 W. 33d st., New York.

## BELLS.

**MARTIN, RUFUS & CO.**, 13 Park Row, New York.

**W. S. & CO.**, Chicago, Ill.

**Star Bell Co.**, Easthampton, Mass.

**VAN DUZEN & TIFT**, 102 and 104 E. Second st., Cincinnati, O.

## BELTING.

**Page Belting Co.**, Concord, N. H. (Branches—19 Federal st., Boston; 111 Liberty st., New York; 161 Lake st., Chicago; 301 and 303 Clark st., St. Louis, Mo.; 47 and 1307 W. 12th st., Kansas City, Mo.)

**Schultz Belting Co.**, St. Louis, Mo. (Branches—Curts & Co., 40 W. 40th st., New York; 100 W. 4th St., Cincinnati, Philadelphia; Frank Peirce, Boston, Mass.)

## BENDING MACHINES.

**Ayres, Abraham**, 502 to 518 W. 45th st., New York.

**BROOKLYN RAILWAY SUPPLY CO.** (The), 44 Walworth st., Brooklyn, N. Y.

**Chester Steel Castings Co.**, 407 Library st., Philadelphia.

**Craig, Wm. P.**, 95 Liberty st., New York.

**Greely, The E. S. & Co.**, 5 and 7 Dey st., New York.

**Harris, T. Wm. G.**, 2 Nassau st., New York.

**Howard, Childs & Co.**, Hamilton Building, Pittsburgh.

**LEWIS & FOWLER MANUFACTURING CO.** (The), 27 to 35 Walworth st., Brooklyn, N. Y.

**PUGH & RUSSELL**, Stewart Bldg., New York; Phenix Bldg., Chicago, Ill.

**WM. WHARTON, JR. & CO.** (Incorporated), 25th st. and Washington ave., Philadelphia, Pa.

**BOLTS.**

**Daytons, L. M.**, Cincinnati, O.

**BRACES.**

**JOHNSON STEEL STREET RAIL CO.** (The), Johnstown, Pa. (vide Cable Yokes)

**DICKSON, C. K.**, Seely Northern Central Ry. Co., St. Louis, Mo.

## BRAKE CHAINS.

**ROEBLING'S SONS CO.**, JOHN A., Trenton, N. J. (Branches—117 and 119 Liberty st., New York; 171 and 173 Lake st., Chicago; 14 Drum st., San Francisco, Cal.)

## BRAKE HANDLES.

**BRILL (J. G.) CO.**, Philadelphia.

**MARTIN, RUFUS & CO.**, 13 Park Row, New York.

**STEPHENSON (JOHN) COMPANY**, Lim., 47 E. 27th st., New York. (Branch—Phenix Bldg., Chicago, Ill.)

## BRAKE RODS.

**BRILL (J. G.) CO.**, Philadelphia.

**BROWNELL & WIGHT CAR CO.**, 2300 Broadway, St. Louis, Mo.

**Dederick, Z. P.**, Sherman, Texas.

**Howard, Childs & Co.**, Hamilton Building, Pittsburgh.

**Laclede Car Co.**, 4500 N. Second st., St. Louis, Mo.

**LEWIS & FOWLER MFG. CO.** (The), 27 to 35 Walworth st., Brooklyn, N. Y.

**Martin, Rufus & Co.**, 13 Park Row, New York.

**PUGH & RUSSELL**, Stewart Bldg., New York; Phenix Bldg., Chicago, Ill.

**STEPHENSON (JOHN) COMPANY**, Limited, 47 E. 27th st., New York. (Branch—Phenix Bldg., Chicago, Ill.)

## BRAKES.

**ANDREWS, FRANK H.**, 545 W. 33rd st., New York (Works—25 to 35 West 33rd st., 33 to 53 W. 34th st., New York. Branches—37 Central st., Boston; Lakeside Building, Chicago; Southern Hotel, St. Louis, Mo.; Agents—W. S. Greengrove & Co., San Francisco, Cal.; Bacon Bros., 377 St. Paul st., Montreal, Can.)

**BRILL (J. G.) CO.**, Philadelphia.

**BROWNELL & WIGHT CAR CO.**, 2300 Broadway, St. Louis, Mo.

**Dederick, Z. P.**, Sherman, Texas.

**Greely, The E. S. & Co.**, 5 and 7 Dey st., New York.

**Howard, Childs & Co.**, Hamilton Building, Pittsburgh.

**Laclede Car Co.**, 4500 N. Second st., St. Louis, Mo.

**LEWIS & FOWLER MFG. CO.** (The), 27 to 35 Walworth st., Brooklyn, N. Y.

**Martin, Rufus & Co.**, 13 Park Row, New York.

**PUGH & RUSSELL**, Stewart Bldg., New York; Phenix Bldg., Chicago, Ill.

**STEPHENSON (JOHN) COMPANY**, Limited, 47 E. 27th st., New York. (Branch—Phenix Bldg., Chicago, Ill.)

**Wilson, Horace M.** (Agent), Troy, N. Y.

## BRAKE SHOES.

**ANDREWS, FRANK H.**, 545 W. 33rd st., New York (vide Brakes).

**Ayres, Abraham**, 502 to 518 W. 45th st., New York.

**BALTIMORE CAR WHEEL CO.** (The), Baltimore, Md. (vide Axles).

**BRILL (J. G.) CO.**, Philadelphia.

**BROWNELL & WIGHT CAR CO.**, 2300 Broadway, St. Louis, Mo.

**Chester Steel Castings Co.**, 407 Library st., Philadelphia.

**Dederick, Z. P.**, Sherman, Texas.

**Fonte, Otto A.**, Cleveland, O.

**FULTON FOUNDRY**, Cleveland, Ohio (vide Axles).

**Greely, The E. S. & Co.**, 5 and 7 Dey st., New York.

**Griffin, The E. S. & Co.**, 13 Park Row, New York.

**Howard, Childs & Co.**, Hamilton Building, Philadelphia.

**Laclede Car Co.**, 4500 N. Second st., St. Louis, Mo.

**LEWIS & FOWLER MFG. CO.** (The), 27 to 35 Walworth st., Brooklyn, N. Y.

**Martin, Rufus & Co.**, 13 Park Row, New York.

**PUGH & RUSSELL**, Stewart Bldg., New York; Phenix Bldg., Chicago, Ill.

**St. Thomas Car Wheel Co.**, St. Thomas, Ont., Canada.

**STEPHENSON (JOHN) COMPANY**, Lim., New York.

**STREET RAILWAY SUPPLY CO.**, Cleveland, Ohio.

**Unionized Fibre Co.**, Wilmington, Del. (New York 100 W. 4th st., New York.)

**WM. WHARTON, JR. & CO.** (Incorporated), 25th st. and Washington ave., Philadelphia, Pa.

**WHITNEY, A., & SONS**, Philadelphia, Pa.

## BROOMS (Bass and Rattan).

**BROOKLYN RAILWAY SUPPLY CO.** (The), 44 Walworth st., Brooklyn, N. Y.

**Martin, Rufus & Co.**, 13 Park Row, New York.

**TRUSHES (Horse).**

**Phenix Brothers & Co.**, 512 Arch st., Philadelphia.

**BRUSHES (Paint).**

**HOFFEN, DEVOE & CO.**, 176 Randolph st., Chicago, Ill.

## CABLE CASTINGS.

**HOFFEN, DEVOE & CO.**, Cincinnati, O.

**HORACE A. KEEFER O.** (The), Kansas City, Mo.

**LANE & BODLEY CO.** (The), 267 to 283 Water st., Cincinnati, O.

**St. Louis Malleable Iron Works**, St. Louis, Mo.

**WAY, FULTON & CO.** (The), 23rd and Wood sts., Philadelphia, Pa.

## CABLE RAILWAY PATENTS.

**Cable Railway Co.** (The), 329 Market st., San Francisco.

**National Cable Railway Co.** (The), 140 Nassau st., New York.

**Patent Cable Railway Co.** (The), 106 St. Nicholas st., New York.

**Patent Cable Tramway Corporation** (The), Limited, 2 Victoria Mansions, Victoria st., S. W., London, Eng.

**Rastausen Cable Co.**, room 606 First National Bank Building, Chicago, Ill.

## CABLE RAILWAY PLANTS.

**HAYEN, OWENS & REMSCHER CO.** (The), Hamilton, Ohio.

**LANE & BODLEY CO.** (The), 267 to 283 Water st., Cincinnati, O.

**Poole & Hunt**, Baltimore, Md. (vide Grips).

**Walker Manufacturing Co.**, Cleveland, O.

## CABLE RY. SWITCHES (Automatic).

**Wm. Wharton, Jr. & Co.** (Incorporated), 25th st. and Washington ave., Philadelphia, Pa.

## CABLE RAILWAY WORK.

**WAY, FULTON & CO.** (The), 23rd and Wood sts., Philadelphia, Pa.

## CABLES.

**BRODERICK & BASCON ROPE CO.**, 704 N. Main st., St. Louis, Mo.

**Bullivant & Co.**, 72 Mark Lane, London, E. C.

**California Wire Works**, 329 Market st., San Francisco, Cal. (Branch—0 Oak st., Portland, O.)

**Greely, The E. S. & Co.**, 5 and 7 Dey st., New York.

**Haines Bros.**, 55 Broadway, New York.

**HAZARD MFG. CO.**, Wilkes Barre, Pa. (Branches—18 Terrace, Buffalo, N. Y.; 159 River st., Cleveland, O.; 91 Commercial st., Boston, Mass.; 25 Sante Gay st., Baltimore, Md.; 2500 1st. St., Salt Lake City, Utah; 218 Lake st., Chicago, Ill.; 5 Sixth ave., Pittsburgh, Pa.; 21 Fremont st., San Francisco, Cal.; 703 Market st., Philadelphia, Pa.; 38 S. Delaware ave., Philadelphia, Pa.; 87 Liberty st., New York; Kansas City, Mo.; St. Louis, Mo.; Cincinnati, O.)

**Howard, Childs & Co.**, Hamilton Building, Pittsburgh.

**JOHNSON, TOM L.**, Indianapolis, Ind.

**Post & Company**, Cincinnati, Ohio.

**ROEBLING'S SONS CO.**, JOHN A., Trenton, N. J. (Branches—117 and 119 Liberty st., New York; 171 and 173 Lake st., Chicago; 14 Drum st., San Francisco, Cal.)

**WASHBURN & MOEN MANUFACTURING CO.**, Worcester, Mass. (Warehouses—16 Cliff st., New York; 107 and 109 Lake st., Chicago.)

**CABLE SHEAVES.**

**HOEFINGHOFF & LAWE**, Cincinnati, O.

**St. Louis Malleable Iron Works**, St. Louis, Mo.

**WAY, FULTON & CO.** (The), 23rd and Wood sts., Philadelphia, Pa.

**CABLE YOKES.**

**BALTIMORE CAR WHEEL CO.** (The), Baltimore, Md. (vide Axles).

**Greely, The E. S. & Co.**, 5 and 7 Dey st., New York.

**HOEFINGHOFF & LAWE**, Cincinnati, O.

**Laclede Car Co.**, 4500 N. Second st., St. Louis, Mo.

**JOHNSON STEEL STREET RAIL CO.** (The), Johnstown, Pa. (Branches—Cotton Exchange Building, New Orleans; Phoenix Building, Chicago; Bank of Commerce Building, St. Louis, Mo.; 6 Oliver st., Boston; Stewart Building, New York; Johnston Building, Cincinnati; 22 W. Main st., Louisville, Ky.; Metallic Street Railway Supply Co., 37 State st., Albany, N. Y. (Agent—FRANK H. ANDREWS, 545 W. 33rd st., New York.)

**St. Louis Malleable Iron Works**, St. Louis, Mo.

**Union Foundry & Pullman Car Wheel Works**, Chicago.

**Wm. Wharton, Jr. & Co.** (Incorporated), 25th st. and Washington ave., Philadelphia, Pa.

**CAR BUILDERS.**

**BRILL (J. G.) CO.**, Philadelphia.

**BROWNELL & WIGHT CAR CO.**, 2300 Broadway, St. Louis, Mo.

**Dederick, Z. P.**, Sherman, Texas.

**Dierker, C. Co.**, 117 Second st., E. C. London. (Works—Britannia Engineering Works, Kilmarock, N. E.)

**Falcon Engine & Car Works, Limited**, Loughborough, Eng. (London office—41 Coleman st., E. C.)

**Felzel Car Co.** (The), 108 Wall st., New York.

**Haines Bros.**, 55 Broadway, New York.

**Jones (J. A.) Sons**, West Troy, N. Y.

**KUHLMANN CAR CO.**, 490 St. Clair st., Cleveland, O.

**Laclede Car Co.**, 4500 N. Second st., St. Louis, Mo.

**LANCASTER WAGON CO.** (The), Limited, Lancaster. (London office—1 Victoria st., Westminster, S. W.)

**Metcalf, Gearing & Tregon Works**, Birmingham, England.

**PUGH & RUSSELL**, Stewart Bldg., New York; Phenix Bldg., Chicago, Ill.

**PULLMAN'S PALACE CAR CO.**, Chicago; Pullman, Phila.; Detroit, Mich.

**Robinson & Hild.**, Waterloo, Iowa.

**St. Louis Car Co.** (The), 3023 Broadway, St. Louis, Mo.

**Starling Car and Wagon Co.** (The), Limited, Birkenhead. (London office—6 Gt. Winchester st., Building, E. C.)

**STEPHENSON (JOHN) COMPANY**, Limited, 47 E. 27th st., New York. (Branch—Phenix Bldg., Chicago.)

**CAR (Electric) BUILDERS.**

**Giant's Causeway Electric Tramway** (W. A. Trull, Engineer), Co. Antrim, Ireland.

## CAR CASTINGS.

**ADAMS & WESTLAKE CO.** (The), 110 Ontario st., Chicago, Ill. (Branch—115 Broadway, New York.)

**ANDREWS, FRANK H.**, 545 W. 33rd st., New York (vide Brakes).



**CAR HEATER FITTINGS (Hose, &c.)**  
Gold, Edw. E., & Co., No. car. Frankfort and Cliff sts., New York.

**CAR HEATERS.**  
Greely, The E. S., & Co., 5 and 7 Day st., New York.

**ADAMS & WESTLAKE CO. (The),** 110 Ontario st., Chicago, Ill. (Branch—115 Broadway, New York.)  
Brill (J. G.) Co., Philadelphia.  
**CLINE MFG. CO.,** 277 and 279 S. Canal st., Chicago.  
Clute, Geo. M., West Troy, N. Y.  
Gold, Edw. E., & Co., no. car. Frankfort and Cliff sts., New York.  
Grosvenor, E. S., & Co., 5 and 7 Day st., New York.  
Laricé Car Co., 450 N. Second st., St. Louis, Mo.  
**LEWIS & FOWLER MFG. CO. (The),** 27 to 35 Walworth st., Brooklyn, N. Y.  
Mason & Knapp, Car and Fuel Co., 219 and 221 Market st., St. Louis, Mo.  
**PENNYQUICK HEAT & VENTILATION CO.,** 12 Pearl st., Boston.  
Post & Company, Cincinnati, Ohio.  
**PUGH & RUSSELL,** Stewart Bldg., New York; Phenix Bldg., Chicago, Ill.

**STEPHENSON (JOHN) COMPANY,** Limited, 47 E. 27th st., New York. (Branch—Phenix Bldg., Chicago.)  
**STREET RAILWAY SUPPLY CO.,** Cleveland, Ohio.

**CAR LAMPS.**  
**ADAMS & WESTLAKE CO. (The),** 110 Ontario st., Chicago; 115 Broadway, New York.  
Brill (J. G.) Co., Philadelphia.  
**BROWNELL & WIGHT CAR CO.,** 2300 Broadway, St. Louis, Mo.  
Dayton Mfg. Co. (The), Dayton, Ohio.  
Footst, Orlo A., Cleveland, O.  
Greely, The E. S., & Co., 5 and 7 Day st., New York.  
Laricé Car Co., 450 N. Second st., St. Louis, Mo.  
**LEWIS & FOWLER MFG. CO. (The),** 27 to 35 Walworth st., Brooklyn, N. Y.  
Miller, Chas. B., 310 E. 14th st., New York.  
Post & Company, Cincinnati, Ohio.  
**PUGH & RUSSELL,** Stewart Bldg., New York; Phenix Bldg., Chicago, Ill.

**STEPHENSON (JOHN) COMPANY,** Limited, 47 E. 27th st., New York. (Branch—Phenix Bldg., Chicago.)  
**SMITH, JOSEPHINE D.,** 350 Pearl st., New York.

**CAR MORTISES.**  
**LANE & BODLEY CO. (The),** 267 to 283 Water st., Cincinnati, Ohio.

**CARS (Sand and Salt).**  
**BROOKLYN RAILWAY SUPPLY CO. (The),** 44 Walworth st., Brooklyn, N. Y.

**CAR SASH.**  
Ayers' Patent Sash Holder Co., 242 Stewart Bldg., New York.  
Brill (J. G.) Co., Philadelphia.  
**BROWNELL & WIGHT CAR CO.,** 2300 Broadway, St. Louis, Mo.  
Dayton Mfg. Co. (The), Dayton, Ohio.  
Dederick, Z. P., Sherman, Texas.  
Greely, The E. S., & Co., 5 and 7 Day st., New York.  
KUHLMANN CAR CO., 490 St. Clair st., Cleveland, O.  
Laricé Car Co., 450 N. Second st., St. Louis, Mo.  
**PUGH & RUSSELL,** Stewart Bldg., New York; Phenix Bldg., Chicago, Ill.

**STEPHENSON (JOHN) COMPANY,** Limited, 47 E. 27th st., New York. (Branch—Phenix Bldg., Chicago.)

**CAR SEATS.**  
**ADAMS & WESTLAKE CO. (The),** 110 Ontario st., Chicago; 115 Broadway, New York.  
Brill (J. G.) Co., Philadelphia.  
**BROWNELL & WIGHT CAR CO.,** 2300 Broadway, St. Louis, Mo.  
Dayton Mfg. Co. (The), Dayton, Ohio.  
Dederick, Z. P., Sherman, Texas.  
Greely, The E. S., & Co., 5 and 7 Day st., New York.  
KUHLMANN CAR CO., 490 St. Clair st., Cleveland, O.  
Laricé Car Co., 450 N. Second st., St. Louis, Mo.  
**PUGH & RUSSELL,** Stewart Bldg., New York; Phenix Bldg., Chicago, Ill.

**HAITFORD WOVEN WIRE MATTRESS CO. (The),** postoffice box 363, Hartford, Conn.  
**KUHLMANN CAR CO.,** 490 St. Clair st., Cleveland, O.  
Laricé Car Co., 450 N. Second st., St. Louis, Mo.  
Post & Company, Cincinnati, Ohio.  
**PUGH & RUSSELL,** Stewart Bldg., New York; Phenix Bldg., Chicago, Ill.

**PURDY & HUNTINGTON CO.,** Limited, 60 Shoe Lane, E. C., London.

**STEPHENSON (JOHN) COMPANY,** Limited, 47 E. 27th st., New York. (Branch—Phenix Bldg., Chicago.)  
Wakefield Traction Co., Boston, Mass. (Branches—644 Market st., San Francisco; 143 and 146 Washburn st., Chicago; 924 Broadway, and 8 Park pl., New York.)

**CARS (Second Hand).**  
Brill (J. G.) Co., Philadelphia.  
**BROOKLYN RAILWAY SUPPLY CO. (The),** 44 Walworth st., Brooklyn, N. Y.  
**BROWNELL & WIGHT CAR CO.,** 2300 Broadway, St. Louis, Mo.  
Greely, The E. S., & Co., 5 and 7 Day st., New York.  
Haines Bros., 55 Broadway, New York.  
Hampreys & Sons, 1 Broadway, New York.  
Martin, Rufus, & Co., 13 Park Row, New York.  
**PUGH & RUSSELL,** Stewart Bldg., New York; Phenix Bldg., Chicago, Ill.

**CAR SHEDS AND STABLES.**  
Evans, H. D., Sunnyside Works, Horsney Rise, N. London.

**CAR SIGNALS.**  
Brill (J. G.) Co., Philadelphia.  
Martin, Rufus, & Co., 13 Park Row, New York.

**CAR SIGNS.**  
Brill (J. G.) Co., Philadelphia.  
Martin, Rufus, & Co., 13 Park Row, New York.

**CAR SPRINGS.**  
ANDREWS, FRANK H., 545 W. 33rd st., New York (vide Brakes).  
**BALTIMORE CAR WHEEL CO. (The),** Baltimore, Md. (vide Axles).  
**BEMIS CAR BOX CO.,** Springfield, Mass.  
Brill (J. G.) Co., Philadelphia.  
**BROWNELL & WIGHT CAR CO.,** 2300 Broadway, St. Louis, Mo.  
Chil & Richter, Oswego, N. Y.  
Diamond State Car Spring Co., 8th and Railroad av., Wilmington, Del.  
Footst, Orlo A., Cleveland, O.  
Frucht, A. A., Car Spring Co., Pittsburgh, Pa.  
Greely, The E. S., & Co., 5 and 7 Day st., New York.  
Howard, Childs & Co., Hamilton Bldg., Pittsburgh, Pa.  
**LEWIS & FOWLER MFG. CO. (The),** 27 to 35 Walworth st., Brooklyn, N. Y.

Pickering Spring Co., Limited, Philadelphia, Pa.  
Post & Company, Cincinnati, Ohio.  
**PUGH & RUSSELL,** Stewart Bldg., New York; Phenix Bldg., Chicago, Ill.  
**STEPHENSON (JOHN) COMPANY,** Limited, 47 E. 27th st., New York. (Branch—Phenix Bldg., Chicago.)  
**STREET RAILWAY SUPPLY CO.,** Cleveland, Ohio.  
**VOISE, LEICHAID,** 13 Barclay st., New York. (Branches—107 E. 12th st., St. Louis; 117 Adams Express Bldg., Chicago, Ill.)

**CAR STAIRS.**  
**BAKER, W. S. GRAFF,** care Brown, Shipley & Co., London (vide Car Starters).  
**BALTIMORE CAR WHEEL CO. (The),** Baltimore, Md. (vide Car Wheels).  
Broadwell, C. B., 169 Laurel st., New Orleans, La.  
Chester Steel Castings Co., 407 Library st., Philadelphia.  
Greely, The E. S., & Co., 5 and 7 Day st., New York.  
Post & Company, Cincinnati, Ohio.  
Wiscer & Yall, 272 Park st., Cleveland, Ohio.

Haldox W. O., Louisville, Ky.

**CAR TRIMMINGS.**  
**ADAMS & WESTLAKE CO. (The),** 110 Ontario st., Chicago; 115 Broadway, New York.  
Brill (J. G.) Co., Philadelphia.  
**BROWNELL & WIGHT CAR CO.,** 2300 Broadway, St. Louis, Mo.  
Dayton Mfg. Co. (The), Dayton, Ohio.  
Footst, Orlo A., Cleveland, O.  
Greely, The E. S., & Co., 5 and 7 Day st., New York.  
Laricé Car Co., 450 N. Second st., St. Louis, Mo.  
**LEWIS & FOWLER MFG. CO. (The),** 27 to 35 Walworth st., Brooklyn, N. Y.  
Miller, Chas. B., 310 E. 14th st., New York.  
Post & Company, Cincinnati, Ohio.  
**PUGH & RUSSELL,** Stewart Bldg., New York; Phenix Bldg., Chicago, Ill.

**STEPHENSON (JOHN) COMPANY,** Limited, 47 E. 27th st., New York. (Branch—Phenix Bldg., Chicago.)  
**SMITH, JOSEPHINE D.,** 350 Pearl st., New York.  
Stewart & Matton Mfg. Co. (The), 2032 N. 10th st., White Edward C., 531 W. 33rd st., New York.

**CAR WHEELS.**  
ANDREWS, FRANK H., 545 W. 33rd st., New York (vide Brakes).  
**BAKER, W. S. GRAFF,** care Brown, Shipley & Co., London (vide Car Starters).  
**BALTIMORE CAR WHEEL CO. (The),** Baltimore, Md. U. S. A. (Agents—O. W. Meyenberg & Co., Chicago and St. Louis; W. S. Graf Baker, care of Brown, Shipley & Co., London; E. G. England, BEMIS CAR BOX CO., Springfield, Mass.)  
**LEWIS & FOWLER MFG. CO. (The),** 27 to 35 Walworth st., Brooklyn, N. Y.  
Brill (J. G.) Co., Philadelphia.  
**BROWNELL & WIGHT CAR CO.,** 2300 Broadway, St. Louis, Mo.  
Chester Steel Castings Co., 407 Library st., Philadelphia.  
Dederick, Z. P., Sherman, Texas.  
Greely, The E. S., & Co., 5 and 7 Day st., New York.  
FULTON FOUNDRY, Cleveland, O. (vide Axles).  
Griffin, Thos. F., & Sons, Buffalo, N. Y.  
Griffin, Wm. & Sons, Rochester, N. Y.  
Island ave., Chicago, Ill.  
Haldiford's Steel Foundry Co., Attercliffe, Sheffield, Eng.  
HOBACE A. KEEFER CO. (The), Kansas City, Mo.  
Howard, Childs & Co., Hamilton Bldg., Pittsburgh, Pa.  
Knoxville Car Wheel Co., Knoxville, Tenn.  
Laricé Car Co., 450 N. Second st., St. Louis, Mo.  
**LEWIS & FOWLER MFG. CO. (The),** 27 to 35 Walworth st., Brooklyn, N. Y.  
Meyenberg, O. W., 204 N. 3d st., St. Louis, Mo. (Branch—Phenix Bldg., Chicago, Ill.)  
Miller & Co., London Road Foundry, Edinburgh, Scot.  
PUGH & RUSSELL, Stewart Bldg., New York; Phenix Bldg., Chicago, Ill.

**STEPHENSON (JOHN) COMPANY,** Limited, 47 E. 27th st., New York. (Branch—Phenix Bldg., Chicago.)  
St. Thomas Car Wheel Co., St. Thomas, Ont., Canada.  
**STREET RAILWAY SUPPLY CO.,** Cleveland, Ohio.  
WHITNEY, A., & SONS, Philadelphia, Pa.

**CEMENTS (For Cable Roads).**  
EMPIRE WAREHOUSE CO., 210 Market st., Chicago.

**CHAINS.**  
JOHNSTON STEEL STREET RAIL CO. (The), Johnston, Pa. (vide Cable Yokes).  
Wilson, Pease & Co., Middleborough-on-Tees, Eng.

**CHANGE BELTS.**  
Martin, Rufus, & Co., 13 Park Row, New York.

**CHANGE RECEPICLES.**  
MASSON, MILTON L., Agent for Slawson's Patents, 385 Avenue A., New York.  
WALLES MANUFACTURING CO., 76 and 78 E. Water st., Syracuse, N. Y.  
Whitlog, T. J., 74 South Place, Finsbury, London.

**CHANNEL PLATES.**  
ANDREWS, FRANK H., 545 W. 33rd st., New York (vide Brakes).  
Ayes, Abraham, 520 to 518 W. 45th st., New York.  
Chil & Richter, Oswego, N. Y.  
HOBACE A. KEEFER CO. (The), Kansas City, Mo.  
Howard, Childs & Co., Hamilton Bldg., Pittsburgh, Pa.  
JOHNSTON STEEL STREET RAIL CO. (The), Johnston, Pa. (vide Cable Yokes).  
**LEWIS & FOWLER MFG. CO. (The),** 27 to 35 Walworth st., Brooklyn, N. Y.  
Meyenberg, O. W., & Co., 204 N. 3d st., St. Louis, Mo. (Branch—Phenix Bldg., Chicago, Ill.)  
**PUGH & RUSSELL,** Stewart Bldg., New York; Phenix Bldg., Chicago, Ill.

**WM. WHARTON, JR. & CO. (Incorporated),** 25th st. and Washington ave., Philadelphia, Pa.

**CHIMNEYS, BURNERS & WICKS.**  
**ADAMS & WESTLAKE CO. (The),** 110 Ontario st., Chicago; 115 Broadway, New York.  
Clute, Geo. M., West Troy, N. Y.  
**SMITH, JOSEPHINE D.,** 350 Pearl st., New York.

**CLUTCH AXLES.**  
**BALTIMORE CAR WHEEL CO. (The),** Baltimore, Md. (vide Car Wheels).  
Empire Aisle Mfg. Co., 23 Nassau st., New York.

**COLORS.**  
COFFIN, DEVOE & CO., 176 Randolph st., Chicago, Ill.  
Sherwin-Williams Co., (The), 100 Canal st., Cleveland, O. (Branches—24 Jackson st., Chicago, Ill.; 178 Fulton st., New York.)

**CONCRETE MIXERS.**  
Caldwell, H. W., 123 W. Washington st., Chicago.  
Kaestner Chas. & Co., 309 S. Canal st., Chicago, Ill.

**CONNECTING TRACKS.**  
JOHNSTON STEEL STREET RAIL CO. (The), Johnston, Pa. (vide Cable Yokes).

**COSTS AND CHARGES OF BUILDERS.**  
ANDREWS, FRANK H., 545 W. 33rd st., New York (vide Brakes).

**BALTIMORE CAR WHEEL CO. (The),** Baltimore, Md. (vide Car Wheels).  
Chester Steel Castings Co., 407 Library st., Philadelphia.  
Craig, W. F., 65 Liberty st., New York.  
Dederick, Z. P., Sherman, Texas.  
FULTON FOUNDRY, Cleveland, O. (vide Axles).  
Greely, The E. S., & Co., 5 and 7 Day st., New York.  
HOBACE A. KEEFER CO. (The), Kansas City, Mo.  
Howard, Childs & Co., Hamilton Bldg., Pittsburgh, Pa.

**JOHNSTON STEEL STREET RAIL CO. (The),** Johnston, Pa. (vide Cable Yokes).  
Johnston Hl. Foundry, Johnston, Pa.  
**LEWIS & FOWLER MFG. CO. (The),** 27 to 35 Walworth st., Brooklyn, N. Y.  
Meyenberg, O. W., 204 N. 3d st., St. Louis, Mo. (Branch—Phenix Bldg., Chicago, Ill.)  
Pennsylvania Steel Co., Philadelphia (vide Axles).  
**PUGH & RUSSELL,** Stewart Bldg., New York; Phenix Bldg., Chicago, Ill.

**SNEAD & HIBB,** Louisville, Ky.  
**WM. WHARTON, JR. & CO. (Incorporated),** 25th st. and Washington ave., Philadelphia, Pa.

**CROSSINGS (Cable and Electric Ity.)**  
Wm. Wharton, Jr., & Co. (Incorporated), 25th st. and Washington ave., Philadelphia, Pa.

**CURBS.**  
WAY FOUNDRY CO. (The), 23d and Wood sts., Philadelphia, Pa.

**DOOR STOPS.**  
**ADAMS & WESTLAKE CO. (The),** 110 Ontario st., Chicago; 115 Broadway, New York.  
Brill (J. G.) Co., Philadelphia, Pa.  
**BROWNELL & WIGHT CAR CO.,** 2300 Broadway, St. Louis, Mo.  
Greely, The E. S., & Co., 5 and 7 Day st., New York.  
Haycox Door Fastener Co., 1158 Euclid ave., Cleveland, Ohio.  
Miller Chas. B., 310 E. 14th st., New York.  
Post & Company, Cincinnati, Ohio.  
**PUGH & RUSSELL,** Stewart Bldg., New York; Phenix Bldg., Chicago, Ill.

**DRAW HEADS.**  
Brill (J. G.) Co., Philadelphia, Pa.  
**STEPHENSON (JOHN) COMPANY,** Limited, 47 E. 27th st., New York. (Branch—Phenix Bldg., Chicago.)

**DRIVING MACHINERY.**  
HOBACE A. KEEFER CO. (The), Kansas City, Mo.  
LANE & BODLEY CO. (The), 267-283 Water st., Cincinnati, Ohio.  
Pooie & Hunt, Baltimore, Md. (vide Grips).

**DUST GUARDS (For Oil Boxes).**  
VULCANIZED FIBRE CO., Wilmington, Delaware. (New York office, 15 Day st.)

**ELECTRIC RAILWAY CASTINGS.**  
WM. WHARTON, JR., & CO. (Incorporated), 25th st. and Washington ave., Philadelphia, Pa.

**ELECTRIC RAILWAY PATENTS.**  
OVERHEAD CONDUCTOR ELECTRIC RAILWAY CO. (The), Chicago, Ill.  
FITCHBURGH, PAIRES ELECTRIC BY & TRACTION INCREASING SYSTEM, A. H. Henderson, Pitts Mgr., 27 Chamber of Commerce st., New York.

**ELECTRIC RAILWAYS (Equipment).**  
BENTLEY-KNIGHT ELECTRIC RAILWAY CO., 115 Broadway, New York, Constructors. (Rhode Island Leocomotive Works.)  
DAFT ELECTRIC LIGHT CO. (The), 115 Broadway, New York. (Factory at Jersey City, N. J.) (Sub. Cos.—Electric Power Co., 115 Broadway, New York; Safety Electric Power Co., 41 Wall st., New York; Safety Electric Power & Railway Co., 41 Wall st., New York; Mass. Electric Power Co., Boston; and Rhode Island Electric Power Co., Providence, R. I.)  
SAFETY ELECTRIC CONSTRUCTION CO. (Balt. Sign Co.), 41 Wall st., New York. (Factory at Greenville, N. Y.)

**SEAGUE ELECTRIC RAILWAY & MOTOR CO.,** 16 and 18 Broad st., New York. (Special work at New York factory, 510 W. 30th st. Standard work at the Edison Machine Works, New York.) (Branches—55 Oliver st., Boston; 20 Caron delet st., New Orleans; 133 Jefferson ave., Detroit; 185 Dearborn st., Chicago; 250 Broadway, New York; 119 S. 4th st., Philadelphia; 117 Public sq., Cleveland, O.)  
VANDEPOLE ELECTRIC MFG. CO., 15, 17, 19 and 21 N. Clinton st., Chicago. (Branch—45 Broadway, New York.)

**ELEVATED RAILWAYS.**  
Meigs Elevated Railway Construction Co., 225 Bridge East Cambridge, Mass.  
Riley Railway Construction Co. (The), Bloomfield, N. J. (Branches—93 Milk st., Boston; 196 Greenwich st., New York.)



## ENGINEERS' INSTRUMENTS (Survey).

ALOE, A. S. &amp; CO., 300 N. Fourth st., St. Louis, Mo.

## ENGRAVERS.

VANDERCOOK &amp; CO., Chicago, Ill.

## FARE BOXES.

ADAMS &amp; WESTLAKES CO. (The), 110 Ontario st., Chicago; 115 Broadway, New York.

Beaman, T. L., Knoxville, Tenn.

BROWNELL &amp; WIGHT CAR CO., 2300 Broadway, St. Louis, Mo.

Dederick, Z. P., Sherman, Texas.

Greely, The E. S., &amp; Co., 5 and 7 Day st., New York; Haines Bros., 55 Broadway, New York.

HORACE A. KEEFER CO. (The), Kansas City, Mo.

JOHNSON, TOM, 34, Indianapolis, Ind.

Laclede Car Co., 4500 N. Second st., St. Louis, Mo.

LEWIS &amp; FOWLER MFG. CO. (The), 27 to 35 Walworth st., Brooklyn, N. Y.

MANSON, MILTON L., (agent for Slawson's boxes), 365 Avenue A, New York.

PUGH &amp; RUSSELL, Stewart Bldg., New York; Phenix Bldg., Chicago, Ill.

STEPHENSON (JOHN) COMPANY, Lima, New York.

WALKES MFG. CO., 76 and 78 E. Water st., Syracuse, N. Y.

Wells &amp; Sanderson, 1804 Millston st., San Francisco, Cal.

Whiting, P. O. 74 South Place, Finsbury, London.

## FARE COLLECTORS (Automatic).

Greely, The E. S., &amp; Co., 5 and 7 Day st., New York; Haines Bros., 55 Broadway, New York.

Hays (Joseph) &amp; Sons, Leeds. (London office—93 High Holborn, W. C., London.)

Laclede Car Co., 4500 N. Second st., St. Louis, Mo.

LEWIS &amp; FOWLER MFG. CO. (The), 27 to 35 Walworth st., Brooklyn, N. Y.

STEPHENSON (JOHN) COMPANY, Limited, 47 E. 27th st., New York. (Branch—Phenix Bldg., Chicago.)

## FARE REGISTERS.

Bell Punch Co. (The) Limited, 24 Tabernacle st., Finsbury sq., E. C., London.

Brill (J. G.) Co., Philadelphia.

Greely, The E. S., &amp; Co., 5 and 7 Day st., New York; Haines Bros., 55 Broadway, New York.

Hays (Joseph) &amp; Sons, Leeds. (London office—93 High Holborn, W. C., London.)

Laclede Car Co., 4500 N. Second st., St. Louis, Mo.

LEWIS &amp; FOWLER MFG. CO. (The), 27 to 35 Walworth st., Brooklyn, N. Y.

Marshall Fare Register Co., Cleveland, O.

Post &amp; Company, Cincinnati, Ohio.

PUGH &amp; RUSSELL, Stewart Bldg., New York; Phenix Bldg., Chicago, Ill.

RAILWAY REGISTER MFG. CO. (Jas. McCredie, president, Buffalo, N. Y.); Ed. Headle, manager, 1193 Broadway, New York; J. F. Courtney, general agent, 423 Walnut st., Philadelphia, Pa.

Standard Index and Register Co., 138 Fulton st., New York.

STEPHENSON (JOHN) COMPANY, Limited, 47 E. 27th st., New York. (Branch—Phenix Bldg., Chicago.)

## FASTENINGS.

Cambria Iron Co., 218 S. 4th st., Philadelphia. (vide Axes.)

## FEED CUTTERS.

BELLE CITY MFG. CO., Racine, Wis.

Kuestner, Charles &amp; Co., 303 S. Canal, Chicago.

PUGH &amp; RUSSELL, Stewart Bldg., New York; Phenix Bldg., Chicago, Ill.

Ross Manufacturing Co., Springfield, O.

## FEED MILLS.

Foss Mfg. Co., the Springfield, O.

Kaestner, Chas. &amp; Co., 303 S. Canal st., Chicago.

Martin, Rufus &amp; Co., 13 Park Row, New York.

Noye, The J. T. Mfg. Co., Buffalo, N. Y. (Branches at Chicago, Ill., and Minneapolis, Minn.)

PUGH &amp; RUSSELL, Stewart Bldg., New York; Phenix Bldg., Chicago, Ill.

## FLOOR PAINT.

CHICAGO WOOD FINISHING CO., 143 and 145 S. Clinton st., Chicago, Ill.

## FOLDING MATS.

BEADLE, EDWARD, 1393 Broadway, New York

Post &amp; Company, Cincinnati, Ohio.

Warneck &amp; Toiffer, 211 E. 22d st., New York. "Rolling Wood Mat."

## FRIGS.

ANDREWS, FRANK H., 545 W. 33rd st., New York (vide Brakes).

Ayres, Abraham, 502 to 518 W. 45th st., New York.

BALTIMORE CAR WHEEL CO. (The), Baltimore, Md. (vide Car Wheels).

Chester Steel Castings Co., 407 Library st., Philadelphia.

Craig, Wm. F., 35 Liberty st., New York.

Dederick, Z. P., Sherman, Texas.

FULTON FOUNDRY, Cleveland, O. (vide Axes).

Greely, The E. S., &amp; Co., 5 and 7 Day st., New York.

HORACE A. KEEFER CO. (The), Kansas City, Mo.

Howard, Childs &amp; Co., Hamilton Bldg., Pittsburgh, Pa.

JOHNSON STEEL SHOE &amp; NAIL CO. (The), Johnston, Pa. (vide Cable Yokes).

Johnston Railroad Frog &amp; Switch Co., 307 Walnut st., Philadelphia.

LEWIS &amp; FOWLER MFG. CO. (The), 27 to 35 Walworth st., Brooklyn, N. Y.

Metallic Screw &amp; Bolt Supply Co., Albany, N. Y. (vide Cable Yokes).

Meyersburg, O. W., &amp; Co., 204 N. 3d st., St. Louis, Mo.

PUGH &amp; RUSSELL, Stewart Bldg., New York; Phenix Bldg., Chicago, Ill.

WAY FOUNDRY CO. (The), 23rd and Wood sts., Philadelphia, Pa.

WM. WHARTON, JR. &amp; Co. (Incorporated), 25th st. and Washington ave., Philadelphia, Pa.

Whiting Manufacturing Co., Cedar Rapids, Iowa.

## GLASS.

Mississippi Glass Co., Main and Angelica sts., St. Louis, Mo. (Agent—Gilbert S. King, 102 Chambers st., New York.)

The Western Sand Blast Co., nw. cor. Clinton and Jackson sts., Chicago, Ill.

## GREASE.

Chicago Lubricant Mfg. Co., 51 Dearborn st., Chicago.

Leib Lubricating Co., Buffalo, N. Y. (Agents—Frazz &amp; Ennis, Wilkes Barre, Pa.)

## GRINDERS (Car Wheel).

Greely, The E. S., &amp; Co., 5 and 7 Day st., New York.

Post &amp; Company, Cincinnati, Ohio.

PUGH &amp; RUSSELL, Stewart Bldg., New York; Phenix Bldg., Chicago, Ill.

## GRIPS (Cable).

ANDERS, D. B., 2313 Ridge Ave., Philadelphia, Pa.

BALTIMORE CAR WHEEL CO. (The) Baltimore, Md. (vide Car Wheels).

Chester Steel Castings Co., 407 Library st., Philadelphia.

John, H. &amp; Gould &amp; Co., 305 to 311 S. 3d st. and 31st and 32d Market sts., and 37 and 39 N. 2d st., Philadelphia.

JOHNSON, TOM, L., Indianapolis, Ind.

LACLEDE CAR CO., 4500 N. Second st., St. Louis, Mo.

LANE &amp; BODLEY CO. (The), 267-283 Water st., Cincinnati, Ohio.

Pugh &amp; Russell, Baltimore, Md. (Works at Woodberry, W. Va.)

Wilson, D. &amp; Co., 102 and 104 E. 2d st., Cincinnati, O.

WM. WHARTON, JR. &amp; Co. (Incorporated), 25th st. and Washington ave., Philadelphia, Pa.

## GROOMING MACHINES.

PUGH &amp; RUSSELL, Stewart Bldg., New York; Phenix Bldg., Chicago, Ill.

## GROOVED CURVES.

ANDREWS, FRANK H., 545 W. 33rd st., New York (vide Brakes).

Craig, Wm. F., 35 Liberty st., New York.

FULTON FOUNDRY, Cleveland, Ohio (vide Axes).

Haines Bros., 55 Broadway, New York.

Howard, Childs &amp; Co., Hamilton Bldg., Pittsburgh, Pa.

JOHNSON STEEL SHOE &amp; NAIL CO. (The), Johnston, Pa. (vide Cable Yokes).

LEWIS &amp; FOWLER MFG. CO. (The), 27 to 35 Walworth st., Brooklyn, N. Y.

Meyersburg, O. W., &amp; Co., 204 N. 3d st., St. Louis, Mo. (Branch—Phenix Bldg., Chicago, Ill.)

Pennsylvania Steel Co., Philadelphia (vide Axes).

PUGH &amp; RUSSELL, Stewart Bldg., New York; Phenix Bldg., Chicago, Ill.

SNEAD &amp; BIRD, Louisville, Ky.

WM. WHARTON, JR. &amp; Co. (Incorporated), 25th st. and Washington ave., Philadelphia, Pa.

## HAMERS.

Pratt &amp; Whitney, Buffalo, N. Y.

## HAMERS COULPERS.

DICKSON, C. H., Sec'y Northern Central Ry. Co., St. Louis, Mo.

## HARNESSES.

Brill (J. G.) Co., Philadelphia.

Leckie (John) &amp; Co., London (12 St. Mary Axe, E. C.).

Marlin, Rufus &amp; Co., 13 Park Row, New York.

PUGH &amp; RUSSELL, Stewart Bldg., New York; Phenix Bldg., Chicago, Ill.

## HEAD-LIGHTS &amp; LANTERNS.

ADAMS &amp; WESTLAKES CO. (The), 110 Ontario st., Chicago; 115 Broadway, New York.

SMITH, JOSEPHINE D., 352 Pearl st., New York.

## HORSE PADS.

McClain, E. C., Cincinnati.

## HORSE-SHOE NAILS.

Champion Nail Co., Appleton, Wis.

Howard, Childs &amp; Co., Hamilton Bldg., Pittsburgh, Pa.

Kimball, R. D., Michigan ave. and Lake st., Chicago, Ill.

Northwestern Horse Nail Co., 232 S. Clinton st., Chicago.

PUGH &amp; RUSSELL, Stewart Bldg., New York; Phenix Bldg., Chicago, Ill.

Putnam Nail Co., Neponset p. O., Boston, Mass.

The United Horse Shoe and Nail Co., Limited, 115 Canton st., E. C., London.

## HORSE SHOES.

BYRDEN FORGED HORSE SHOE WORKS, LIMITED, Catsaqua, Pa. (General Sales Agent—J. B. White, 94 West st., New York.)

Howard, Childs &amp; Co., Hamilton Bldg., Pittsburgh, Pa.

PUGH &amp; RUSSELL, Stewart Bldg., New York; Phenix Bldg., Chicago, Ill.

The United Horse Shoe and Nail Co., Limited, 115 Canton st., E. C., London.

## HORN BLASTERS.

BURKE, P. F., 360 Dorchester av., Boston, Mass. (vide Ties, Calks).

## HYDRAULIC JACKS.

Brill (J. G.) Co., Philadelphia.

Greely, The E. S., &amp; Co., 5 and 7 Day st., New York.

Howard, Childs &amp; Co., Hamilton Bldg., Pittsburgh, Pa.

Post &amp; Company, Cincinnati, Ohio.

PUGH &amp; RUSSELL, Stewart Bldg., New York; Phenix Bldg., Chicago, Ill.

Watson &amp; Company, 210 E. 43rd st., New York.

## JOINT PLATES.

WAY FOUNDRY CO. (The), 23rd and Wood sts., Phila.

## JOURNAL BOXES.

ANDREWS, FRANK H., 545 W. 33rd st., New York (vide Brakes).

BAKER, W. S. GRAFF, care Brown, Shipley &amp; Co., Loudon (vide Car Starters).

BALTIMORE CAR WHEEL CO. (The), Baltimore, Md. (vide Car Wheels).

Barrett Mfg. Co., 8 Oliver st., Boston.

BEMIS CAR BOX CO., Springfield, Mass.

Brill (J. G.) Co., Philadelphia.

BROWNELL &amp; WIGHT CAR CO. (The), 44 Walworth st., Brooklyn, New York.

BROWNELL &amp; WIGHT CAR CO., 2306 Broadway, St. Louis, Mo.

Chaplin Mfg. Co., 69 Wall st., New York.

Chester Steel Castings Co., 407 Library st., Philadelphia.

FULTON FOUNDRY, Cleveland, Ohio (vide Axes).

Greely, The E. S., &amp; Co., 5 and 7 Day st., New York.

Howard, Childs &amp; Co., Hamilton Bldg., Pittsburgh, Pa.

Keystone Smelting Co. (The), Limited, 33rd st., Pittsburgh, Pa.

Laclede Car Co., 4500 N. Second st., St. Louis, Mo.

LEWIS &amp; FOWLER MFG. CO. (The), 27 to 35 Walworth st., Brooklyn, N. Y.

Meyersburg, O. W., &amp; Co., 204 N. 3d st., St. Louis, Mo.

Miller, Chas. B., 310 E. 14th st., New York.

Post &amp; Company, Cincinnati, Ohio.

PUGH &amp; RUSSELL, Stewart Bldg., New York; Phenix Bldg., Chicago, Ill.

SNEAD &amp; BIRD, Louisville, Ky.

STEPHENSON (JOHN) COMPANY, Limited, 47 E. 27th st., New York. (Branch—Phenix Bldg., Chicago.)

STREET RAILWAY SUPPLY CO., Cleveland, Ohio.

Wilson, D. &amp; Co., 102 and 104 E. 2d st., Cincinnati, Ohio.

WM. WHARTON, JR. &amp; Co. (Incorporated), 25th st. and Washington ave., Philadelphia, Pa.

Whiting Mfg. Co., Cedar Rapids, Iowa.

WILM. THOMAS, &amp; SONS, Philadelphia, Pa.

## KNIVES.

ANDREWS, FRANK H., 545 W. 33rd st., New York

WAY FOUNDRY CO. (The), 23rd and Wood sts., Philadelphia, Pa.

## LAMP HOUSE LATCH.

STEPHENSON (JOHN) COMPANY, Limited, 47 E. 27th st., New York. (Branch—Phenix Bldg., Chicago.)

## LAMP TRIMMINGS.

ADAMS &amp; WESTLAKES CO. (The), 110 Ontario st., Chicago, Ill.; 115 Broadway, New York.

Post &amp; Company, Cincinnati, Ohio.

SMITH, JOSEPHINE D., 352 Pearl st., New York.

## MATTINGS.

See Upholstery, Mats, Etc.

## MOTORS.

Brill (J. G.) Co., Philadelphia, Pa.

Haines Bros., 55 Broadway, New York.

PUGH &amp; RUSSELL, Stewart Bldg., New York; Phenix Bldg., Chicago, Ill.

Standard Friction Engine Co., 12 Chartres st., New Orleans, La.

Tole St. Car Motor System, 310 Chestnut st., Philadelphia.

## MOTORS (Electric).

BENTLEY-KNIGHT ELECTRIC RAILWAY CO., 115 Broadway, New York.

Cleveland Electric Motor Co., First Nat'l Bank Bldg., Cleveland, Ohio. (Contractors.)

DAFT ELECTRIC LIGHT CO. (The), 115 Broadway, New York.

Greely, The E. S., &amp; Co., 5 and 7 Day st., New York.

Haines Bros., 55 Broadway, New York.

Henry Electric Railway Co., Kansas City, Mo.

HORACE A. KEEFER CO. (The), Kansas City, Mo.

Julien Electric Co., 120 Broadway, New York.

Keth, N. S., 30 Nevada block, San Francisco, Cal.

LEWIS &amp; FOWLER MFG. CO. (The), 27 to 35 Walworth st., Brooklyn, N. Y.

SAFETY ELECTRIC CONSTRUCTION CO. (DAFT ELECTRIC LIGHT CO.), 41 Wall, New York.

SPRAGUE ELECTRIC RAILWAY &amp; MOTOR CO., 16 and 18 Broad st., New York (vide Electric Railways).

VAN DER BRUG, ELECTRIC MFG. CO., 15 to 21 Clinton st., Chicago, Ill. (Branch—45 Broadway, N. Y.)

Weiss, T. J., 851 Pavilion ave., Jersey City Heights, N. J.

## MOTORS (Gas).

The Conley Motor Co., 177 Broadway, New York.

## MOTORS (Steam).

BALDWIN LOCOMOTIVE WORKS, Philadelphia.

Black, Hawthorn &amp; Co., Gateshead-on-Tyne, England.

Dick, Kerr &amp; Co., 101 Leadenhall st., E. C. London (vide Car Builders).

Falcon Engine &amp; Car Works, Limited, Loughborough, Leicestershire, England.

Greely, The E. S., &amp; Co., 5 and 7 Day st., New York.

Green, Thos., &amp; Son, Limited, Smithfield Iron Works, Leeds, &amp; Surrey Works, Blackfriars, St. E., London.

Haines Bros., 55 Broadway, New York.

Henschel &amp; Sohn, Cassel, Prussia.

New York Safe Steam Power Co., 64 S. Canal st., Chicago.

POWELL, H. K. &amp; Co., Pittsburgh, Pa.

PUGH &amp; RUSSELL, Stewart Bldg., New York; Phenix Bldg., Chicago, Ill.

## OFFICE FURNITURE, PAPER, ETC.

AHOE, A. S., &amp; Co., 30 E. 30th st., New York.

Hale &amp; Kilburn Mfg. Co. (The), 48 and 50 N. 6th st., Philadelphia, Pa.

The Globe Gr., Cincinnati, Ohio.

## OIL AND PISTON TIGHT CAR GEARING.

BALTIMORE CAR WHEEL CO. (The), Baltimore, Md. (vide Car Wheels).

## OILS.

Duncan, Watson &amp; Co., Dashwood House, New Broad st., E. London.

Vacuum Oil Co., Rochester, N. Y. (Branches—208 Home Insurance Building, Chicago; 10th and Spruce sts., St. Louis, Mo.; 96 Water st., New York; 17 Corn St., Bgd., Cincinnati; 45 Purchase st., Boston; 130 First av., Pittsburgh; 305 Walnut st., Philadelphia; 212 1/2 Wash. av., St. Louis; 92 South St., Baltimore, Md.; 138 St. James st., Montreal, and 96 King st., West, Toronto, Canada.)

## OMNIBUS HARDWARE.

ADAMS &amp; WESTLAKES CO. (The), 110 Ontario st., Chicago; 115 Broadway, New York.

## PAINTS.

Brill (J. G.) Co., Philadelphia.

BROWNELL &amp; WIGHT CAR CO., 2300 Broadway, St. Louis, Mo.

CHICAGO WOOD FINISHING CO., 143 and 145 S. Clinton st., Chicago, Ill.

CORFEN, DEVOE &amp; CO., 176 Randolph st., Chicago, Ill.

IRON CLAD PAINT CO., 9 Case Bldg., Cleveland, O.

Laclede Car Co., 4500 N. Second st., St. Louis, Mo.

Lowe's Metallic Paint Co., Chattanooga, Tenn.

Martin, Rufus &amp; Co., 13 Park Row, New York.

Peabody, Hy. W., &amp; Co., Mason Building Boston

(Branches—81 New st., New York; Leadenhall House, Leadenhall st., E. C., London, Eng.)

Post &amp; Company, Cincinnati, Ohio.

PUGH &amp; RUSSELL, Stewart Bldg., New York; Phenix Bldg., Chicago, Ill.

Sherwin-Williams Co. (The), Cleveland, Ohio (vide Colors).



SNEAD & BIRB, Louisville, Ky. STEPHENSON (JOHN) COMPANY, Limited, 47 E. 27th st., New York. (Branch—Phenix Bldg., Chicago.) STREET RAILWAY SUPPLY CO., Cleveland, Ohio. WM. WHARTON, J.R., & Co. (Incorporated), 25th st. and Washington ave., Philadelphia, Pa. WILNEY A. & SONS, Philadelphia, Pa.

PHOSPHOR BRONZE, Etc. Tabal Smelting Works, 700 So. Broad st., Philadelphia. PHOSPHOR BRONZE CABLE GRIPS. Van Duzen & TOL, 182 and 104 E. Second st., Cincinnati, Ohio.

POLISHES. CHICAGO WOOD FINISHING CO., 143 and 145 S. Clinton st., Chicago, Ill. CLINE MFG. CO., 277 and 279 N. Canal st., Chicago. Gould, J. H., & Gould & Co., Philadelphia (vide Grips). Haines Bros., 55 Broadway, New York. PUGH & RUSSELL, Stewart Bldg., New York; Phenix Bldg., Chicago, Ill.

POLISHING MACHINERY. Watson & Stillman, 210 E. 43rd st., New York. PRESSES (Car Wheels). ANDREWS, FRANK H., 545 W. 33rd st., New York (vide Brakes). BRILL (J. G.), Philadelphia. HAYES, ABRAHAM, 502 to 518 W. 45th st., New York. PUGH & RUSSELL, Stewart Bldg., New York; Phenix Bldg., Chicago, Ill. Watson & Stillman, 210 E. 43rd st., New York.

PULLEYS AND SHEAVES. LANE & BODLEY CO. (The), 267-283 Water st., Cincinnati, Ohio. Pools & Hunt, Baltimore, Md. (vide Grips). PUNCHES AND SHEARS. Watson & Stillman, 210 E. 43rd st., New York. RAILWAY REGISTER MFG. CO., 1193 Broadway, New York (vide Registering Punches).

RAILWAY AGENTS. Peabody, Hour, & Co., Boston (vide Paints). RAILS (Curved). ANDREWS, FRANK H., 545 W. 33rd st., New York (vide Brakes). AYRES, ABRAHAM, 502 to 518 W. 45th st., New York. CRAIG, WM. F., 95 Liberty st., New York. FULTON FOUNDRY, Cleveland, O. (vide Axles). Haines Bros., 55 Broadway, New York. HORACE A. KEEFER CO. (The), Kansas City, Mo. Howard, Childs & Co., Hamilton Bldg., Pittsburgh, Pa. JOHNSON STEEL STREET RAIL CO. (The), Johnston, Pa. (vide Cable Yokes). LEWIS & FOWLER MFG. CO. (The), 27 to 35 Walworth st., Brooklyn, N. Y. LONGSTREET, D. F., Providence, R. I. (Agents—Wm. Wharton, Jr. & Co., (Incorporated), Philadelphia.) Metallic Street Railway Supply Co., Albany, N. Y. (vide Cable Yokes). MEYSENBURG, O. W., & Co., 204 N. 3d st., St. Louis, Mo. (Branch—Phenix Bldg., Chicago, Ill.) Pennsylvania Steel Co., Philadelphia (vide Axles). PUGH & RUSSELL, Stewart Bldg., New York; Phenix Bldg., Chicago, Ill. St. Thomas Car Wheel Co., St. Thomas, Ont., Canada. STREET RAILWAY SUPPLY CO., Cleveland, Ohio. WM. WHARTON, J.R., & Co. (Incorporated), 25th st. and Washington ave., Philadelphia, Pa. Whitling Manufacturing Co., Cedar Rapids, Iowa.

RAILS (Steel). ANDREWS, FRANK H., 545 W. 33rd st., New York (vide Brakes). AYRES, ABRAHAM, 502 and 518 W. 45th st., New York. CAMBRINA IRON CO., 218 S. 4th st., Philadelphia (vide Axles). Carnegie, Phlips & Co., Limited, 48 Fifth ave., Pittsburgh, Pa. CRAIG, WM. F., 95 Liberty st., New York. Edgerton, Geo. M., 204 N. 3d st., St. Louis, Mo. FULTON FOUNDRY, Cleveland, O. (vide Axles). Haines Bros., 55 Broadway, New York. HORACE A. KEEFER CO. (The), Kansas City, Mo. HOWARD, CHILDS & CO., Hamilton Bldg., Pittsburgh, Pa. JOHNSON STEEL STREET RAIL CO. (The), Johnston, Pa. (Branches—Baltimore Exchange Bldg., New Orleans; Factors Bldg., Chicago; Bank of Commerce Bldg., St. Louis, Mo.; 6 Oliver st., Boston; Stewart Bldg., Chicago; Johnston Bldg., Cincinnati; 252 W. Main st., Louisville, Ky.) LONGSTREET, D. F., Providence, R. I. (Agents—Wm. Wharton, Jr. & Co., Philadelphia, Pa.) Metallic Street Railway Supply Co., Albany, N. Y. (vide Cable Yokes). MEYSENBURG, O. W., & Co., 204 N. 3d st., St. Louis, Mo. (Branch—Phenix Bldg., Chicago, Ill.) North Chicago Rolling Mill Co., 17 Metropolitan block, Chicago. (Branch—New Tuscany bldg., Milwaukee, Wis.) Pennsylvania Steel Co., Philadelphia (vide Axles). Post & Company, Cincinnati, Ohio. PUGH & RUSSELL, Stewart Bldg., New York; Phenix Bldg., Chicago, Ill. Springfield Iron Co. (The), Springfield, Ill. (Branch—15 Dearborn st., Chicago, Ill.) STREET RAILWAY SUPPLY CO., Cleveland, Ohio. WM. WHARTON, J.R., & Co. (Incorporated), 25th st. and Washington ave., Philadelphia, Pa. Worcester Steel Works, Worcester, Mass.

RAILS (Tram and T). HATHAWAY & ROBINSON, 14 Case Bldg., Cleveland, O. Tuor Iron Works, 509 S. 3rd st., New York.

RAILWAYS (Cable) BUILDERS. ANDREWS, FRANK H., 545 W. 33rd st., New York (vide Brakes). BAKER, W. S., GRAFF, care Brown, Shipley & Co., London (vide Car Starters). Gould, J. H., & Gould & Co., Philadelphia. (vide Grips). Haines Bros., 55 Broadway, New York. Hincley, F. E., & Co., Room 606 First National Bank Bldg., Chicago, Ill. Metallic Street Railway Supply Co., Albany, N. Y. (vide Cable Yokes). Miller, D. J., 284 Broadway, New York. National Cable Railway Co., 140 Nassau st., New York. Patent Cable Tramways Corporation, Limited, Victoria Mansions, Westminster S. W., London. WM. WHARTON, J.R., & Co. (Incorporated), 25th st. and Washington ave., Philadelphia, Pa. Wright Construction Co., Phenix Bldg., Chicago. Wright, Messrs., 209 S. 3d st., St. Louis, Mo.

RAILWAYS (Electric) BUILDERS. BENTLEY-KNIGHT ELECTRIC RAILWAY CO., 115 Broadway, New York. Clarkbourne & Co., (Agents for Sprague motors), 119 S. 4th st., Philadelphia.

Cleveland Electric Motor Co. (vide Contractors and Builders). DAFT ELECTRIC LIGHT CO. (The), 115 Broadway, New York. Haines Bros., 55 Broadway, New York. Harris, T. Wm., & Co., 2 Nassau st., room 17, New York. Hayes Electric Railway Co., The, Kansas City, Mo. Jullien Electric Co., 120 Broadway, New York. Metallic Street Railway Supply Co., Albany, N. Y. (vide Cable Yokes). SAFETY ELECTRIC CONSTRUCTION CO. (DAFT SYSTEM), 41 Wall st., New York. SPRAGUE ELECTRIC RAILWAY MFG. CO., 16 and 18 Broad st., New York (vide Electric Railways). D. H. Electric Co., Denver, Col. VAN DEPOTE, ELECTRIC MANUFACTURING CO., 15 to 21 N. Clinton st., Chicago; 45 Broadway, N. Y. WM. WHARTON, J.R., & Co. (Incorporated), 25th st. and Washington ave., Philadelphia, Pa.

RAILWAYS (Horse) BUILDERS. HAKER, W. S., GRAFF, care Brown, Shipley & Co., London (vide Car Starters). CRAIG, WM. F., 95 Liberty st., New York. Haines Bros., 55 Broadway, New York. Harris, T. Wm., & Co., 2 Nassau st., room 17, New York. HATHAWAY & ROBINSON, 14 Case Bldg., Cleveland, O. JOHNSON STEEL STREET RAIL CO. (The), Johnston, Pa. (vide Rails, Steel). LEWIS & FOWLER MFG. CO. (The), 27 to 35 Walworth st., Brooklyn, N. Y. Martin, Rufus, & Co., 13 Park Row, New York. Metallic Street Railway Supply Co., Albany, N. Y. (vide Cable Yokes). WM. WHARTON, J.R., & Co. (Incorporated), 25th st. and Washington ave., Philadelphia, Pa. Wright Construction Co., Phenix Bldg., Chicago.

RAILWAYS (Steam) BUILDERS. Haines Bros., 55 Broadway, N. Y. Harris, T. Wm., & Co., 2 Nassau st., room 17, New York. Metallic Street Railway Supply Co., Albany, N. Y. (vide Cable Yokes). WM. WHARTON, J.R., & Co. (Incorporated), 25th st. and Washington ave., Philadelphia, Pa.

REGISTERING PUNCHES (Alarm). RAILWAY REGISTER MFG. CO., 1193 Broadway, New York (vide Fire Registers). ICE CREAMS. Empire Warehouse Co., 198-204 Market st., Chicago, Ill. McCannan, T. C., Cincinnati, O. Peabody, Hour, & Co., Boston (vide Paints).

LIGHTS. CHICAGO WOOD FINISHING CO., 143 and 145 S. Clinton st., Chicago, Ill. RUBBER TREADS (For Car Steps). Martin, Rufus, & Co., 13 Park Row, New York. STEPHENSON (JOHN) COMPANY, Limited, 47 E. 27th st., New York. (Branch—Phenix Bldg., Chicago.)

SAFETY PULL IRONS. BRILL (J. G.), Philadelphia. SAND BOXES. BRILL (J. G.), Philadelphia. CAR TRACK FRICTION APPLIANCE CO. (The), 1 Tremont Row (room 4), Boston, Mass. (W. T. Butler, general agent). JORDAN MILLS MFG. CO. (The), 32 Nassau st., New York. Laclede Car Co., 4500 N. Second st., St. Louis, Mo. LEWIS & FOWLER MFG. CO. (The), 27 to 35 Walworth st., Brooklyn, N. Y. PUGH & RUSSELL, Stewart Bldg., New York; Phenix Bldg., Chicago, Ill.

SEAT AND SEAT SPRINGS. BRILL (J. G.), Philadelphia. BROWNELL & WIGHT CAR CO., 2300 Broadway, St. Louis, Mo. DAYTON MFG. CO. (The), Dayton, Ohio. Greeley, The E. S., & Co., 5 and 7 Dey st., New York. Hale & Kilburn Mfg. Co. (The), 48 and 50 N. 6th st., New York. HARTFORD WOVEN WIRE MATTRESS CO. (The), 82 Bay St., 163 W. 10th st., London. Laclede Car Co., 4500 N. Second st., St. Louis, Mo. Post & Company, Cincinnati, Ohio. PUGH & RUSSELL, Stewart Bldg., New York; Phenix Bldg., Chicago, Ill.

SHAFING HANGERS AND PULLEYS. LANE & BODLEY CO. (The), 267-283 Water st., Cincinnati, Ohio.

SIGNAL LIGHTS. ADAMS & WESTLAKE CO. (The), 110 Ontario st., Chicago, Ill.; 115 Broadway, New York. BRILL (J. G.), Philadelphia. BROWNELL & WIGHT CAR CO., 2300 Broadway, St. Louis, Mo. Greeley, The E. S., & Co., 5 and 7 Dey st., New York. Laclede Car Co., 4500 N. Second st., St. Louis, Mo. LEWIS & FOWLER MFG. CO. (The), 27 to 35 Walworth st., Brooklyn, N. Y. MARTIN, RUFUS, & CO., 13 Park Row, New York. Post & Company, Cincinnati, Ohio. PUGH & RUSSELL, Stewart Bldg., New York; Phenix Bldg., Chicago, Ill. SMITH, JOE EPHINE D., 250 Pearl st., New York.

SNOW PLOWS. ANDREWS, FRANK H., 545 W. 33rd st., New York (vide Brakes). BRILL (J. G.), Philadelphia. BROOKLYN RAILWAY SUPPLY CO. (The), 44 Walworth st., Brooklyn, N. Y. CRAIG, WM. F., 95 Liberty st., New York. Day, Augustus, 22 Park Place, Detroit, Mich. Haines Bros., 55 Broadway, New York. JOHNSON STEEL STREET RAIL CO. (The), Johnston, Pa. LEWIS & FOWLER MFG. CO. (The), 27 to 35 Walworth st., Brooklyn, N. Y. PUGH & RUSSELL, Stewart Bldg., New York; Phenix Bldg., Chicago, Ill.

SPIKES AND FASTENINGS. CRAIG, WM. F., 95 Liberty st., New York. FULTON FOUNDRY, Cleveland, O. (vide Axles). Greeley, The E. S., & Co., 5 and 7 Dey st., New York. Haines Bros., 55 Broadway, New York. HATHAWAY & ROBINSON, 14 Case Bldg., Cleveland, O. HORACE A. KEEFER CO. (The), Kansas City, Mo. Howard, Childs & Co., Hamilton Bldg., Pittsburgh, Pa. JOHNSON STEEL STREET RAIL CO. (The), Johnston, Pa. (vide Rails, Steel). LEWIS & FOWLER MFG. CO. (The), 27 to 35 Walworth st., Brooklyn, N. Y. Post & Company, Cincinnati, Ohio.

PUGH & RUSSELL, Stewart Bldg., New York; Phenix Bldg., Chicago, Ill. Tuor Iron Works, 509 S. 3rd st., New York. WM. WHARTON, J.R., & Co. (Incorporated), 25th st. and Washington ave., Philadelphia, Pa.

SPICES FOR JOINING WIRE CABLES. HAZARD MANUFACTURING CO. (The), Wilkes-Barre, Pa. (vide Galvan.). SPRING STEEL. CAMBRINA IRON CO., 218 S. 4th st., Philadelphia (vide Axles).

STAINES. CHICAGO WOOD FINISHING CO., 143 and 145 S. Clinton st., Chicago, Ill. STATIONARY ENGINE BUILDERS. Allen, Edw. P., & Co., Milwaukee, Wis. Buckeye Engine Co., Salem, Ohio. (Sales Agents—W. L. Shurpou, 201 Telephone Building, 18 Cortland st., New York; John P. Felt, 30 Oliver st., Boston; Mass.; W. N. Robinson, 207 Clinton and Jackson sts., Chicago, Ill.; Robinson & Corey, St. Paul, Minn.; G. S. Wortner & Son, 705 Market st., St. Louis, Mo.; Derick, Z. P., Sherman, Texas.) PINKHILL LAMINATING MACHINE CO., Pinkhill on the Hudson. HOWARD, CHILDS & CO., Hamilton Bldg., Pittsburgh, Pa. HOOVER, OWENS & RENTSCHLER CO. (The), Hamilton, O. HORACE A. KEEFER CO. (The), Kansas City, Mo. Knebler, Chas., & Co., 303 E. Canal st., Chicago. LANE & BODLEY CO. (The), 267-283 Water st., Cincinnati, Ohio. New York Safety Steam Power Co., 64 S. Canal st., Chicago.

Nov. The J. T. Manufacturing Co., Buffalo, N. Y. (Branches at Chicago, Ill., and Minneapolis, Minn.) Providence Steam Engine Co., Providence, R. I. Smith, Beegs & Reeking, St. Louis, Mo. Tod, Wm., & Co., Youngstown, Ohio. Whitling Manufacturing Co., Cedar Rapids, Iowa.

STEAM BOILERS. Hines, 102 E. Butler, 102 North Main st., St. Louis, Mo. (Agent—J. H. Harris, 82 Madison st., Chicago.) HOOVER, OWENS & RENTSCHLER CO. (The), Hamilton, O.

STORAGE BATTERIES (for Lights, &c.) Brush Electric Co. (The), Cleveland, O. Electrical Accumulator Co. (The), 44 Broadway, New York. Jullien Electric Co., 120 Broadway, New York.

SUPPLIES (General). ANDREWS, FRANK H., 545 W. 33rd st., New York (vide Brakes). BRILL (J. G.), Philadelphia. BROOKLYN RAILWAY SUPPLY CO. (The), 44 Walworth st., Brooklyn, N. Y. BROWNELL & WIGHT CAR CO., 2300 Broadway, St. Louis, Mo. Chester Steel Castings Co., 407 Liberty st., Philadelphia. Child, O. W., & Co., 150 Broadway, New York. CRAIG, WM. F., 95 Liberty st., New York. Derick, Z. P., Sherman, Texas. Dwight, E. P., 407 Liberty st., Philadelphia. Felt, John P., 30 Oliver st., New York. Greeley, The E. S., & Co., 5 and 7 Dey st., New York. Haines Bros., 55 Broadway, New York. HARTFORD WOVEN WIRE MATTRESS CO. (The), 82 Bay St., 163 W. 10th st., London. P. O. box 363, Hartford, Conn. HATHAWAY & ROBINSON, 14 Case Bldg., Cleveland, O. HOWARD, CHILDS & CO., Hamilton Bldg., Pittsburgh, Pa. JESUP, F. W., & Co., 61 Liberty st., New York. JOHNSON STEEL STREET RAIL CO. (The), Johnston, Pa. (vide Rails, Steel). Kimbark, S. D., Michigan ave. and Lake st., Chicago, Ill. LEWIS & FOWLER MFG. CO. (The), 27 to 35 Walworth st., Brooklyn, N. Y. Martin, Rufus, & Co., 13 Park Row, New York. Metallic Street Railway Supply Co. (The), Albany, N. Y. Phoenix Steel Wire Co., 199 E. Randolph st., Chicago, Ill. Post & Company, Cincinnati, Ohio. PUGH & RUSSELL, Stewart Bldg., New York; Phenix Bldg., Chicago, Ill. Saxton, J. C., 52 Broadway, New York. SMITH, JOE EPHINE D., 250 Pearl st., New York. STEPHENSON (JOHN) COMPANY, Limited, 47 E. 27th st., New York. (Branch—Phenix Bldg., Chicago.) STREET RAILWAY SUPPLY CO., Cleveland, Ohio. WM. WHARTON, J.R., & Co. (Incorporated), 25th st. and Washington ave., Philadelphia, Pa. White, Edward, 330 W. 33rd st., New York.

SWEEPING MACHINES (Dirt or Street). BROOKLYN RAILWAY SUPPLY CO. (The), 44 Walworth st., Brooklyn, N. Y.

SWITCH CASTINGS. HATHAWAY & ROBINSON, 14 Case Bldg., Cleveland, O.

SWITCH ROPES. ROEBLING'S SONS CO., JOHN A., 117 and 119 Liberty st., New York.

SWITCHES. ANDREWS, FRANK H., 545 W. 33rd st., New York (vide Brakes). AYRES, ABRAHAM, 502 to 518 W. 45th st., New York. BALTIMORE CAR WHEEL CO. (The), Baltimore, Md. (vide Car Wheels). CRAIG, WM. F., 95 LIBERTY ST., NEW YORK. Derick, Z. P., Sherman, Texas. FULTON FOUNDRY, Cleveland, O. (vide Axles). Greeley, The E. S., & Co., 5 and 7 Dey st., New York. Haines Bros., 55 Broadway, New York. HOWARD, CHILDS & CO., Hamilton Bldg., Pittsburgh, Pa. JOHNSON STEEL STREET RAIL CO. (The), Johnston, Pa. (vide Rails, Steel). Jullien Electric Co., 120 Broadway, New York. LEWIS & FOWLER MFG. CO. (The), 27 to 35 Walworth st., Brooklyn, N. Y. Metallic Street Railway Supply Co., Albany, N. Y. (vide Cable Yokes). Pennsylvania Steel Co., Philadelphia (vide Axles). PUGH & RUSSELL, Stewart Bldg., New York; Phenix Bldg., Chicago, Ill. SNEAD & BIRB, Louisville, Ky. WAY FOUNDRY CO. (The), 23rd and Wood sts., Philadelphia, Pa. WM. WHARTON, J.R., & Co. (Incorporated), 25th st. and Washington ave., Philadelphia, Pa. WHITE, EDWARD, 330 W. 33rd st., New York. Whitney Mfg. Co., Cedar Rapids, Iowa.

SWITCHES (Automatic). ANDREWS, FRANK H., 545 W. 33rd st., New York (vide Brakes). AYRES, ABRAHAM, 502 to 518 W. 45th st., New York. CRAIG, WM. F., 95 LIBERTY ST., NEW YORK. Derick, Z. P., Sherman, Texas. FULTON FOUNDRY, Cleveland, O. (vide Axles). Greeley, The E. S., & Co., 5 and 7 Dey st., New York.



HATHAWAY & ROBISON, Room 14 Case Building, Cleveland, Ohio.  
 HORACE A. KEEFER CO. (The), Kansas City, Mo.  
 JOHNSON STEEL STREET RAIL CO. (The), Johnston, Pa. (vide Rails, Steel).  
 LEWIS & FOWLER MFG. CO. (The), 27 to 35 Walworth st., Brooklyn, N. Y.  
 Metallic St. Ry. Supply Co., Albany, N. Y. (vide Cable Yokes).  
 PUGH & RUSSELL, Stewart Bldg., New York; Phenix Bldg., Chicago, Ill.  
 WM. WHARTON, JR., & CO. (Incorporated), 25th st. and Washington ave., Philadelphia, Pa.  
 WHITE, M. M., & CO., 531 W. 33rd st., New York.

#### TENSION CARRIAGES.

LANE & BODLEY CO. (The), Water st., Cincinnati, O.  
 POOLE & HUNT, Baltimore, Md. (vide Grips).

#### TICKETS.

Bell Punch Co. (The), Limited, 24 Tabernacle st., Finsbury, E. C., London.  
 Foster, C. A., Merchants' Row, Northampton, England.  
 Jones (J. M. W.), Stationery & Printing Co., Dearborn st., Chicago, Ill.  
 Whiting T. J., 7a South Place, Finsbury, E. C., London.

#### TIE PLATES.

JOHNSON STEEL STREET RAIL CO. (The), Johnston, Pa. (vide Rails, Steel).

#### TIE RAILS.

JOHNSON STEEL STREET RAIL CO. (The), Johnston, Pa. (vide Rails, Steel).

#### TOE CALKS.

BURKE, P. H., 309 Dorchester ave., Boston, Mass. (Agents—Kelly, Maus & Co., Chicago, Ill.; Livings-ton Horse Nail Co., New York, N. Y.)  
 Cantrina Iron Co., 218 S. 4th st., Philadelphia (vide Axles).  
 Howard, Childs & Co., Hamilton Building, Pittsburgh, Pa.  
 PUGH & RUSSELL, Stewart Bldg., New York; Phenix Bldg., Chicago, Ill.

#### TOOLS (Track and Stable).

BROOKLYN RAILWAY SUPPLY CO. (The), 44 Walworth st., Brooklyn, N. Y.  
 Craig, Wm. P., 95 Liberty st., New York.  
 Greeley, The E. S., & Co., 5 and 7 Day st., New York.  
 Haines Bros., 55 Broadway, New York.  
 Howard, Childs & Co., Hamilton Building, Pittsburgh, Pa.  
 Lee & Hunt, Arkwright works, Nottingham, England.  
 LEWIS & FOWLER MFG. CO. (The), 27 to 35 Walworth st., Brooklyn, N. Y.  
 Martin, Rufus, & Co., 13 Park Row, New York.  
 Post & Company, Cincinnati, Ohio.  
 PUGH & RUSSELL, Stewart Bldg., New York; Phenix Bldg., Chicago, Ill.  
 STREET RAILWAY SUPPLY CO., Cleveland, Ohio.  
 Wm. Wharton, Jr., & Co. (Incorporated), 25th st. and Washington ave., Philadelphia, Pa.

#### TRACK CASTINGS.

ANDREWS, FRANK H., 545 W. 33rd st., New York (vide Brakes).  
 Ayres, Abraham, 502 to 518 W. 45th st., New York.  
 BALTIMORE CAR WHEEL CO. (The), Baltimore, Md. (vide Car Wheels).  
 BOWLER & CO., Cleveland, O.  
 Chester Steel Castings Co., 407 Library st., Philadelphia.  
 Craig, Wm. P., 95 Liberty st., New York.  
 Dederick, Z. F., Sherman, Texas.  
 Foote, Orio A., Cleveland, O.  
 FULTON FOUNDRY, Cleveland, Ohio (vide Axles).  
 HAINES BROS., 55 Broadway, New York.  
 HORACE A. KEEFER CO. (The), Kansas City, Mo.  
 Howard, Childs & Co., Hamilton Building, Pittsburgh, Pa.  
 JOHNSON STEEL STREET RAIL CO. (The), Johnston, Pa. (vide Rails, Steel).  
 LEWIS & FOWLER MFG. CO. (The), 27 Walworth st., Brooklyn, N. Y.  
 Metallic Street Railway Supply Co., Albany, N. Y. (vide Cable Yokes).  
 Meyersburg O. W., & Co., 204 N. 3d st., St. Louis, Mo. (Branch—Phenix Bldg., Chicago, Ill.)  
 PHOENIX Steel Wire Broom & Brush Co., 199 E. Randolph st., Chicago, Ill.  
 PUGH & RUSSELL, Stewart Bldg., New York; Phenix Bldg., Chicago, Ill.  
 St. Thomas Car Wheel Co., St. Thomas, Ont., Canada.  
 STREET RAILWAY SUPPLY CO., Cleveland, Ohio.  
 SNEAD & BIRB, Louisville, Ky.  
 WAY FOUNDRY CO. (The), 23rd and Wood sts., Philadelphia, Pa.  
 WM. WHARTON, JR., & CO. (Incorporated), 25th st. and Washington ave., Philadelphia, Pa.  
 Whiting Mfg. Co., Cedar Rapids, Iowa.  
 WHITNEY, A., & SONS, Philadelphia, Pa.

#### TRACK SCRAPERS.

ANDREWS, FRANK H., 545 W. 33rd st., New York (vide Brakes).  
 Brill (J. G.) Co., Philadelphia, Pa.  
 Craig, Wm. P., 95 Liberty st., New York.  
 Day, Augustus, 22 Park Place, Detroit, Mich.  
 Foote, Orio A., Cleveland, O.  
 Giddens, H. H., 111 Erie st., Chicago, Ill.  
 JOHNSON, TOM L., Indianapolis, Ind.  
 Lactate Car Co., 3500 N. Second st., St. Louis, Mo.  
 Little, H. H., 111 Erie st., Chicago, Ill.  
 PHOENIX Steel Wire Broom & Brush Co., 199 E. Randolph st., Chicago, Ill.  
 PUGH & RUSSELL, Stewart Bldg., New York; Phenix Bldg., Chicago, Ill.  
 STREET RAILWAY SUPPLY CO., Cleveland, Ohio.  
 Van Dorn Iron Co., Cleveland, O.

#### TRACK SWEEPERS.

ANDREWS, FRANK H., 545 W. 33rd st., New York (vide Brakes).  
 Brill (J. G.) Co., Philadelphia, Pa.  
 BROOKLYN RAILWAY SUPPLY CO. (The), 44 Walworth st., Brooklyn, N. Y.  
 Craig, Wm. P., 95 Liberty st., New York.  
 Greeley, The E. S., & Co., 5 and 7 Day st., New York.  
 Haines Bros., 55 Broadway, New York.  
 LEWIS & FOWLER MFG. CO. (The), 27 to 35 Walworth st., Brooklyn, N. Y.  
 MARTIN, RUFUS, & CO., 13 Park Row, New York.  
 PHOENIX Steel Wire Broom & Brush Co., 199 E. Randolph st., Chicago, Ill.  
 Post & Company, Cincinnati, Ohio.  
 PUGH & RUSSELL, Stewart Bldg., New York; Phenix Bldg., Chicago, Ill.

#### TRANSER TABLES.

Brill (J. G.) Co., Philadelphia, Pa.  
 Craig, Wm. P., 95 Liberty st., New York.  
 Foote, Orio A., Cleveland, O.  
 FULTON FOUNDRY, Cleveland, Ohio (vide Axles).  
 HAINES BROS., 55 Broadway, New York.  
 HATHAWAY & ROBISON, 14 Case Bldg., Cleveland, O.  
 HORACE A. KEEFER CO. (The), Kansas City, Mo.

LEWIS & FOWLER MFG. CO. (The), 27 to 35 Walworth st., Brooklyn, N. Y.  
 PUGH & RUSSELL, Stewart Bldg., New York; Phenix Bldg., Chicago, Ill.  
 STREET RAILWAY SUPPLY CO., Cleveland, Ohio.  
 WM. WHARTON, JR., & CO. (Incorporated), 25th st. and Washington ave., Philadelphia, Pa.

#### TRANSIT.

ALOPE, A. S., & CO., 300 N. Fourth st., St. Louis, Mo.

#### TURN-OUTS.

ANDREWS, FRANK H., 545 W. 33rd st., New York  
 Craig Wm. P., 95 Liberty st., New York.  
 Dederick, Z. F., Sherman, Texas.  
 FULTON FOUNDRY CO. (The), Cleveland, Ohio.  
 HAINES BROS., 55 Broadway, New York.  
 HORACE A. KEEFER CO. (The), Kansas City, Mo.  
 JOHNSON STEEL STREET RAIL CO. (The), Johnston, Pa. (vide Rails, Steel).  
 LEWIS & FOWLER MFG. CO. (The), 27 to 35 Walworth st., Brooklyn, N. Y.  
 Metallic St. Railway Supply Co., Albany, N. Y. (vide Cable Yokes).  
 Meyersburg O. W., & Co., 204 N. 3d st., St. Louis, Mo. (Branch—Phenix Bldg., Chicago, Ill.)  
 PUGH & RUSSELL, Stewart Bldg., New York; Phenix Bldg., Chicago, Ill.  
 St. Thomas Car Wheel Co., St. Thomas, Ont., Canada.  
 SNEAD & BIRB, Louisville, Ky.  
 STREET RAILWAY SUPPLY CO., Cleveland, Ohio.  
 WM. WHARTON, JR., & CO. (Incorporated), 25th st. and Washington ave., Philadelphia, Pa.

#### TURN TABLES.

ANDREWS, FRANK H., 545 W. 33rd st., New York (vide Brakes).  
 Ayres, Abraham, 502 to 518 W. 45th st., New York.  
 Brill (J. G.) Co., Philadelphia, Pa.  
 Craig, Wm. P., 95 Liberty st., New York.  
 Foote, Orio A., Cleveland, O.  
 FULTON FOUNDRY, Cleveland, O. (vide Axles).  
 Greeley, The E. S., & Co., 5 and 7 Day st., New York.  
 HAINES BROS., 55 Broadway, New York.  
 HATHAWAY & ROBISON, 14 Case Bldg., Cleveland, O.  
 HORACE A. KEEFER CO. (The), Kansas City, Mo.  
 JOHNSON STEEL STREET RAIL CO. (The), Johnston, Pa. (vide Rails, Steel).  
 KAESNER CHAS. & CO., 303 S. Canal st., Chicago, Ill.  
 LEWIS & FOWLER MFG. CO. (The), 27 to 35 Walworth st., Brooklyn, N. Y.  
 Metallic St. Ry. Supply Co., Albany, N. Y. (vide Cable Yokes).  
 PUGH & RUSSELL, Stewart Bldg., New York; Phenix Bldg., Chicago, Ill.  
 SNEAD & BIRB, Louisville, Ky.  
 STREET RAILWAY SUPPLY CO., Cleveland, Ohio.  
 WM. WHARTON, JR., & CO. (Incorporated), 25th st. and Washington ave., Philadelphia, Pa.

#### TYPE WRITERS (and Supplies).

WYCKOFF, BROS., & BERNDT (Remington Standard Type Writer), 138 LaSalle st., Chicago.

#### UPOHSTERY, MATS, ETC.

BEADLE, EDWARD, 1193 Broadway, New York (vide Folding Mats).  
 Eric, Wm. New Haven, Conn.  
 Goff, D., & Sons, Pawtucket, R. I. (Mohair Cush).  
 Gould J. H. & Gould & Co., Philadelphia (vide Grips).  
 HAINES BROS., 55 Broadway, New York.  
 HARTFORD WOVEN WIRE MATTRESS CO. (The), Hartford, Conn.  
 Lynn & Pettit, 707 Market st., Philadelphia, Pa.  
 Warnock & Tomer, 211 E. 22nd st., New York (vide Folding Mats).

#### VARNISHES.

Babeock, John, & Co., 2 Liberty sq., Boston, Mass.  
 Brill (J. G.) Co., Philadelphia.  
 BROWNELL & WIGHT CAR CO., 2300 Broadway, St. Louis, Mo.  
 COFFIN, DEVŌE & CO., 176 Randolph st., Chicago, Ill.  
 Foote, Orio A., Cleveland, O.  
 Giddens & Joy, Cleveland, O.  
 Greeley, The E. S., & Co., 5 and 7 Day st., New York.  
 HAINES BROS., 55 Broadway, New York.  
 MURPHY & CO., 238 McWhorter st., Newark, N. J. (Branches—327 Broadway, New York; 566 Canal st., Cleveland, O.; 262 Walnut av., Chicago; 300 S. 4th st., St. Louis, Mo.)  
 Parrott Varnish Co., Bridgeport, Conn.  
 Pomeroy & Fischer, 30 Frankfort st., New York.  
 Post & Company, Cincinnati, Ohio.  
 PUGH & RUSSELL, Stewart Bldg., New York; Phenix Bldg., Chicago, Ill.  
 Sherwin-Williams Co. (The), Cleveland, O.  
 Shipman & Boies, Newark, N. J.  
 STREET RAILWAY SUPPLY CO., Cleveland, Ohio.  
 Valentine & Co., 345 Broadway, New York (vide Paints).

#### VETERINARY SUPPLIES, Etc.

Arnheim, D., 52 Second av., Pittsburgh, Pa.  
 Humphrey's Homeopathic Medicine Co., 109 Fulton st., New York.  
 PUGH & RUSSELL, Stewart Bldg., New York; Phenix Bldg., Chicago, Ill.  
 Roberts, Broadway, New York.  
 SOMERVILLE, DR. WM., & SONS, 127 Erie st., Buffalo, N. Y.  
 Vacuum Oil Co., Rochester, N. Y. (vide Oils).  
 Williams (Lawrence) & Co., Cleveland, Ohio.

#### WELDING DIE'S (for Sharp Calks).

Burke, P. F., 360 Dorchester av., Boston, Mass. (vide Toe Calks).

#### WINDOW WASHERS (Car).

PHOENIX Steel Wire Broom and Brush Co., 199 E. Randolph st., Chicago, Ill.

#### WIRE AND WIRE ROPES.

Brotherton & Brown Wire Rope Co., St. Louis, Mo.  
 Bullivant & Co., 72 Mark Lane, London, E.C.  
 Cable Railway Co., 329 Market st., San Francisco, Cal.  
 ROBERTS, DR. WM., & SONS, JOHN A. TROUT, N. J. (Branches—117 and 119 Liberty st., New York; 171 and 173 Lake st., Chicago; 14 Drumm st., San Francisco, Cal.)  
 WOOD MILLERS.  
 CHICAGO WOOD FINISHING CO., 143 and 145 S. Clinton st., Chicago, Ill.

#### WOOD SUPPLIES (for Cars).

KUHLMANN CAR CO., 490 St. Clair st., Cleveland, O.

## Patents Gazetted During November.

### PEPER'S CABLE RAILWAY.

Mr. Christian Peper, President St. Louis Railway Co., has devised a cable railway with a chair for supporting the tube or conduit irons, having on each side two pieces forming standards connected together, the double standards on both sides being further connected together by a web.

### DEAN READ'S ELEVATED RAILWAY.

Mr. D. Dean Read, of Boston, has invented an elevated railway structure comprising supporting-columns extending above the road-bed and a lower supporting-truss extended beside and supported on said columns, at a point between the upper and lower ends thereof, and supporting-cables supported on the upper ends of said columns and sustaining said trusses between the columns, an upper truss, vertically over the first, supported on the columns near their upper ends, and cables supported on the upper ends of said columns and sustaining the said upper trusses between the columns, the whole forming a railway co-operating with cars provided with trucks above and below, and co-operating with rails supported on said upper and lower trusses. Also a car-body having a swiveled hanger above, provided with two wheels turning on substantially horizontal axes and arranged side by side in a direction transverse to the car, and supporting tracks below the car, and co-operating upper tracks consisting of an inverted channel having substantially horizontal flanges at its lower edges, on which the wheels of the upper trucks run, and a supporting track below the car body and co-operating with the lower trucks.

### BRILL'S MOTOR CAR.

Messrs. Geo. M. and Jno. A. Brill, Philadelphia, have devised a car or truck frame having affixed to its longitudinal sills or bolsters axle-box pedestals, axle-boxes loosely supported in said pedestals, saddles loosely supported upon the axle-boxes, springs between the saddles and pedestals, and a frame, secured to said saddle. Also a cable motor car or truck frame having affixed to its longitudinal sills or bolsters axle-box pedestals, axle-boxes loosely supported in said pedestals, saddles and loosely supported upon the axle-boxes, springs between the saddles and pedestals, a frame secured to the saddles, and a gripping device supported upon said frame.

### PATTON'S MOTOR FOR STREET CARS.

A patent was granted Nov. 20, to Mr. Wm. H. Patton, Pueblo, Colo., for a street car motor consisting of a combination, with a main frame an axle or shaft and a pulley thereon, of two drive-pulleys journaled adjacent to and movable alternately into engagement with the pulley of the axle or shaft, a drive-power, and a single belt connecting the drive-power with both drive-pulleys.



Patents Continued from page 18.

- 374,081. Street car motor—W. H. Patton, Pueblo, Colo.
- 373,853. Street car motor—A. L. Rich, Alleghency, Pa.
- 373,909. Shackling device for street cars—W. W. Sargent, Fitchburg, Mass.
- 373,989. Cable railway—W. Hopkins, Dubuque, Iowa.
- 371,103. Traction cable grip—E. Smith, Philadelphia. Pa.
- 370,862. Combined car and vehicle rail—J. H. and W. Dryer, South Cedar, Kan.

- 370,935. Car brake and starter—A. V. Dillenbeck, Rochester, N. Y.
- 371,064. Cable railway—C. J. P. Heim, St. Louis, Mo.
- 371,095. Gripper for cable railways—W. H. Paine, Brooklyn, N. Y.
- 370,894. Electric car brake—W. M. Schlesinger, Philadelphia, Pa.
- 370,872. Car propulsion—W. L. Imlay and H. G. Williams, Camden, N. J.
- 371,344. System of railway car propulsion—M. McManus, Philadelphia, Pa.

### DICKSON'S HAME COUPLER.



A Locking, Indestructible Iron-Chain Hame Fastener.

Can be attached to any Hame.

No more annoyance caused by the breaking of Bottom Hame Straps.

The following Street Railroads in St. Louis now have the Fastener in use.

- Miscurl Railway Co.
- People's Railway Co.
- Southern Railway Co.
- Benton-Bellefontaine Railway Co.
- Jefferson Ave. Railway Co.
- Cass Ave. and Fair Grounds R'y Co.
- Union Railway Co.
- Union Depot Railway Co.

### THE DICKSON BRACE. Patent Applied for.

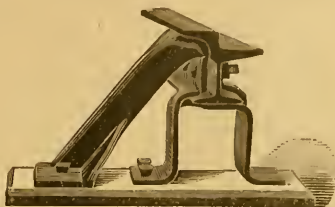

Guaranteed to PREVENT THE SPREADING OF RAILS. Cheaper and more Reliable than Tie Rods. Prevents the wearing of the Street Paving outside the Rail, by TURNING WAGONS OFF THE TRACK.

Adopted by Cass Ave. Road for 8 miles of track. Also by the Northern Central Railway Co. 10 1/4 miles.

C. H. DICKSON, Sec'y, Northern Central Railway Co.,

ST. LOUIS, MO.

### SPONGES FOR STREET RAILWAY SERVICE

A SPECIALTY.

The Only Exclusive Sponge and Chamois House in the West.

J. B. GREENSFELDER & CO., 103 S. 4th St., (Southern Hotel), ST. LOUIS, MO.

Send Postal for Samples and Prices. Cable Address: REVEDOR, ST. LOUIS.

### POND ENGINEERING

COMPANY.

707 & 709 Market St.

ST. LOUIS.

521 Delaware St.,

Kansas City.



### ENGINEERS AND

CONTRACTORS

OF

Steam & Hydraulic

MACHINERY.

Complete Steam Plants for Cable and Electric Railways a Specialty.

### P. F. BURKE,

Successor to C. F. DEWICK & CO.,

Manufacturer of

### Patent Steel Shoe Calks,

BLUNT AND SHARP.

WELDING DIES FOR SHARP, AND HORSE SHOERS' FOOT VISES.

360 Dorchester Avenue, BOSTON, MASS.

For Sale by Iron, Steel and Heavy Hardware Dealers. Send for Circulars.

J. MURRAY MITCHELL,  
President.

KARRICK HIGGS,  
Treasurer.

HENRY S. ISELIN,  
Secretary and Manager.

J. MURRAY MITCHELL,  
(DICKERSON & DICKERSON) Counsel.

# SAFETY ELECTRIC RAILWAY AND POWER COMPANY.

(DAFT SYSTEM.)

## ELECTRIC RAILWAY MOTORS

Electric Light and Power Machines. Electrical Conductors.

We are prepared to build and equip Railways with our Electric System and supply

**LIGHT**  
—AND—  
**POWER**

Machines at the shortest notice.

Complete installation of Central Stations for the distribution of Power a specialty.

Cars equipped with the

**DAFT**  
**Electric System**

can be lighted with the same current that operates the Motor.



DAFT ELECTRIC RAILWAY AT ORANGE, N. J.

Estimates,  
Catalogues,  
and any information furnished on application.

We guarantee the successful operation of our system.

**Heaviest Grades**  
NO OBSTACLE.

On receipt of full particulars, we will send you exact estimate of the cost of equipment and operation under

**Our System.**

We have the only absolutely self-regulating Motor in the World.

From the *Los Angeles Illustrated Herald*, March, 1887.  
The Los Angeles Electric Railway is a corporation organized for the purpose of constructing and operating electric railways in the City of Los Angeles.

The Los Angeles Electric Road is undoubtedly the most successful electric road in the United States. Col. Howard secured the benefit of the working of other roads and adopted the best improvements that experience could suggest. The speed of the road is usually from 10 to 12 miles per hour, as fast as is deemed safe for the streets of the city. The apparatus is under the most perfect control, and can be stopped on the instant, and if necessary, be reversed in motion. Cars have been run at times at a speed of 20 miles per hour.

The road has been running nearly two months and not failed a single day. It has carried in a single afternoon on three cars, a distance of three miles, fifteen hundred passengers.

The Electric Railway Company has now in operation three miles of electric railway on Pico Street, and are building two miles more to reach the Plaza.

The cost of construction is about one-third of a cable road. The cost of maintenance about 60 per cent of a cable road. Its speed can be made greater.

The cost of running an electric road can be estimated at one-half of a horse road, and its capacity four fold greater.

This road is one of the many enterprises that Los Angeles contributes to astonish the visitor, and is daily visited by hundreds of our sojourners.

From the *Los Angeles Times*, March 5, 1887.

### THE ELECTRIC ROAD.

#### A FLATTERING OPINION.

H. C. Moore, Prosecuting Attorney of San Jose, and prominently connected with street railroads in that city and San Francisco, has been here for several days on business—with which he has contrived to mingle considerable pleasure. Mr. Moore is one of the owners of the horse-car system in San Jose—the system embracing about five miles of track, and an investment of about a quarter of a million dollars. The franchise of the company runs out in a year, and the company has applied for a renewal with the privilege of turning the system into an electric road.

To find out the exact facts in the case, Mr. Moore came down here to see for himself. He has examined the Pico Street electric road thoroughly, ridden over it, and is surprised and delighted with it.

After a couple of days' chase, a *Times* representative caught Mr. Moore yesterday, and had a short conversation with him on the subject of his visit. Mr. Moore said: "We heard about your electrical road. I came down and see it for myself, and am surprised at the success and smoothness of your road. I have ridden over it, and must say it is the smoothest riding road I ever rode on. You actually cannot tell, unless you watch some stationary object, just when you start and when you stop. It

Address all communications to

**SAFETY ELECTRIC RAILWAY AND POWER CO.**  
Office, 41 & 43 WALL ST., NEW YORK. Factory, GREENVILLE, N. J.

is a wonderful thing. Now, the Market Street road in San Francisco is the finest cable road on earth. It cost hundreds of thousands of dollars a mile. Your electric road is built very cheaply on an ungraded street whose soil is like ashea when dry, and like mortar when wet; and still, for comfort and smoothness, it is perfection. It is as much ahead of the Market Street cable road as the Market Street road is ahead of a horse railroad. I am more than satisfied with its workings.

From the *Electrical World*, March 26, 1887.

The Daft road, at Los Angeles, is working admirably. The road carried 14,982 passengers during February, and is developing a large and rapidly growing business. It is proposed to adopt the system for a road at San Jose, using a simple form of conduit system. Mr. H. C. Moore, one of the large owners of the San Jose road, which has hitherto been run by horses, inspected the Los Angeles road recently and pronounced a strongly favorable opinion on its merits.

BALTIMORE, Sept. 25, 1886.

SAFETY ELECTRIC RAILWAY AND POWER CO., NEW YORK.

Gentlemen:—In answer to yours of the 23d inst., making inquiries in relation to the Baltimore & Hampden Electric Railroad, I have to say that its success by the change from horse and mule power to electric power under the Daft System has exceeded my highest expectations. It has largely increased the travel on the route, and at a less operating expense than horse power. The road has been running more than a year by electricity with as much regularity as any road in the country. I find less difficulty in getting men to run the motors properly than I do to get men to run the ordinary horse car properly. The road is now being run by persons who before their employment here were unfamiliar with electrical affairs.

T. C. ROBBINS, GENERAL MANAGER.

Report of T. C. ROBBINS, Esq., Manager of Baltimore Union Passenger R. R. Company, showing results of running the Baltimore & Hampden Road by DAFT ELECTRIC MOTORS.

In the year ending September 1st, 1885, with horses, at a speed of 4.033 miles per hour:	In the year ending September 1st, 1886, with Electricity, at a speed of 8 miles per hour:
Passengers carried were..... 227,135	Passengers carried were..... 311,141
Gross Earnings were..... \$11,837.75	Gross Earnings were..... \$15,557.05
Cost of Motive Power was.. 7,117.50	Cost of Motive Power was... 4,380.00
Cost of Motive Power per Passenger per mile was..... .0156	Cost of Motive Power per Passenger per mile was..... .007

- I. An Increase in Traffic of..... 37 per cent nearly
- II. A Reduction in Cost of Motive Power in Gross of..... 38 per cent.
- III. A Reduction in Cost of Motive Power in Gross per Passenger per mile of..... 55 per cent.











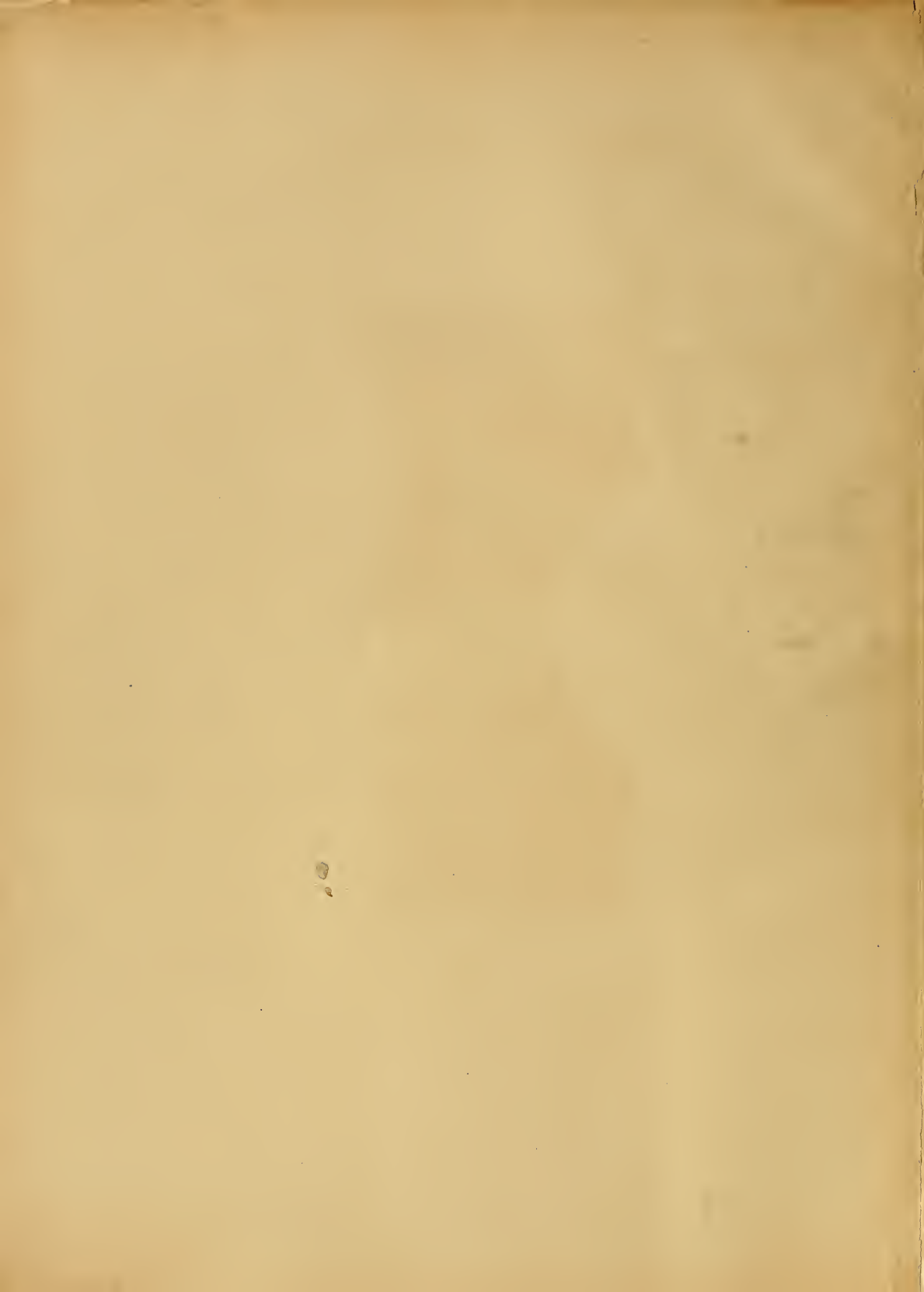



MASSACHUSETTS I

MIT LIBRARIES DUPL



3 9080 02486 5690

ADOPTED BY THE BOARD OF LIBRARIES, MAY 11, 1994

Date Due

Date Due		

Lib-26-67



MASSACHUSETTS I



RULE ADOPTED BY THE LIBRARY COMMITTEE, MAY 19, 1919

If any book, the property of the Institute, shall be lost or seriously injured, as by any marks or writing made therein, the person to whom it stands charged shall replace it by a new copy, or by a **new set** if it forms a part of a set.

Form 1,53-10,000-12 D/19

TF  
.E38  
v.1-2  
1886-1887

126764

TF  
.E38  
v.1-2  
1886-1887

126764  
Street railway gazette.

SIGN this card and present it with book  
at the CIRCULATION DESK.

MASSACHUSETTS INSTITUTE OF  
TECHNOLOGY LIBRARIES

HUMANITIES LIBRARY

