

MIT LIBRARIES



3 9080 02811 0242

V393  
.R467

NAVY DEPARTMENT  
DAVID TAYLOR MODEL BASIN  
WASHINGTON, D. C.

COMPARATIVE TEST OF THE NDRC TOURMALINE AND THE  
TMB DIAPHRAGM AIR-BLAST GAGES

by

B. Sussholz

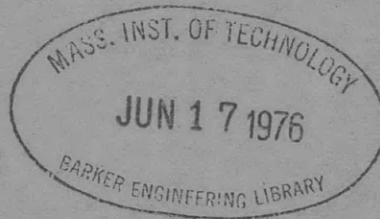

~~CONFIDENTIAL~~

59

August 1946

Report R-282

## DAVID TAYLOR MODEL BASIN

Captain H.E. Saunders, USN  
DIRECTOR

### HYDROMECHANICS

Comdr. E.R. Tilburne, USN

E.H. Kennard, Ph.D.  
CHIEF PHYSICIST

### AEROMECHANICS

Comdr. L.S. Chambers, USN

C.J. Wenzinger  
HEAD AERONAUTICAL ENGINEER

### STRUCTURAL MECHANICS

Comdr. J.O. Baker, USNR

D.F. Windenburg, Ph.D.  
CHIEF PHYSICIST

### ENGINEERING AND DESIGN

Comdr. L.W. Shallenberg, USNR

G.A. DeShazer  
HEAD MECHANICAL ENGINEER

### REPORTS, RECORDS, AND TRANSLATIONS

M.L. Dager  
SENIOR LIBRARIAN

M.C. Roemer  
TECHNICAL EDITOR

---

### PERSONNEL

This test was made possible by the interest and cooperation of Dr. E.B. Wilson, Jr., of Division 2 of the National Defense Research Committee and of Dr. D. Silverman of the Stanolind Oil and Gas Company, Tulsa, Oklahoma, whose staff members H.M. Lang and H.D. Conard made the crystal-gage measurements with the regular Stanolind-NDRC equipment used for recording tourmaline-gage air-blast signals. The crystal-gage records were analyzed and tabulated by Mr. Lang for the comparisons made at the conclusion of the test.

The NDRC gun-range facilities at Carderock, including the laboratory recording equipment, were made available by Dr. H.L. Curtis of the National Bureau of Standards. The cooperation of several members of Dr. Curtis' staff in making the test, namely Dr. C. Moon, I.L. Cooter, E.G. Bennett, and J.E. Potter, is gratefully acknowledged. The gun was operated by Chief Turret Captain E.P. Herrington, USN. The David Taylor Model Basin group consisted of P. Tamarkin, F.G. Harper, and B. Sussholz.

The report was written by Mr. Sussholz.

PLY ADDRESS:  
DR, DAVID TAYLOR  
L BASIN, USN.

1/10-3  
CM)

NAVY DEPARTMENT  
DAVID TAYLOR MODEL BASIN  
WASHINGTON 7, D.C.



11 OCT 1946

om: Director  
: Chief of the Bureau of Ships, Research (330)  
(in duplicate)

bject: David Taylor Model Basin Technical Report -  
Forwarding of.

closure:  
(A) TMB CONFIDENTIAL Report R-282 entitled "Comparative Test  
of the NDRC Tourmaline and the TMB Diaphragm Air-Blast  
Gages," by B. Sussholz, dated August 1946.  
- 12 copies, Serials 1 to 12 inclusive.

1. The enclosure is forwarded for the information and files of  
the Bureau of Ships. It is requested that a copy be furnished to Ship  
Protection (424).

2. It is recommended that, of the twelve (12) copies furnished  
herein (4) be forwarded to the Naval Attache, London for distribution in  
Great Britain, and that two (2) copies each be sent direct to the  
British Admiralty Delegation and the Director of Scientific Research  
(424) of the British Admiralty, at their Washington offices.

3. In case this request is not complied with in full, because  
of policy or other reasons, it is requested that the Taylor Model  
Basin be furnished with a copy of the Bureau of Ships letter making  
clear the actual distribution to these agencies, so that the Taylor Model  
Basin distribution records will be complete.

*H. E. Saunders*  
H. E. SAUNDERS

Copy, with copies of Encl (A)  
indicated, to:

Chief of Naval Research, with 2 copies, Serials 13, 14  
Chief of the Bureau of Aeronautics, with 2 copies, Serials 15, 16  
Chief of the Bureau of Ordnance, with 4 copies, Serials 17, 18, 19, 20  
Chief of the Bureau of Yards and Docks, with 2 copies, Serials 21, 22  
Director, Naval Engineering Experiment Station, Annapolis, Md., with  
1 copy, Serial 23  
Director, U.S. Naval Research Laboratory with 2 copies, Serials 24, 25  
Supt., U.S. Naval Gun Factory, Washington 25, D.C. with 2 copies  
Serials 26 and 27  
CO, U.S. Naval Mine Warfare Test Station, Solomons Branch, with 1 copy,  
Serial 28  
OffinCh., Naval Ordnance Laboratory, U.S. Naval Gun Factory,  
Washington 25, D.C. with 2 copies, Serials 29 and 30



4/A10-3  
CM)

CONFIDENTIAL

Subject: David Taylor Model Basin Technical Report -  
Forwarding of.

Copy, with copies of Encl (A)  
as indicated, to: (cont'd)

Commanding Officer, Naval Proving Ground, Dahlgren, Va., with 2 copies, Serials 31, 32  
Commanding Officer, U.S. Navy Electronics Laboratory, San Diego 52, Calif.,  
- with 1 copy, Serial 33  
Director, U.S. Navy Underwater Sound Laboratory, Fort Trumbull, New  
London, with 1 copy, Serial 34  
Commanding Officer, Ordnance Investigation Laboratory, Naval Powder Factory, Indian Head,  
Md., with 2 copies, Serials 35, 36  
Commanding Officer, U.S. Navy Material Laboratory, Naval Base Station, Brooklyn, N. Y.  
with 2 copies, Serials 37, 38  
Chief of Engineers, U.S. Army, War Department, with 2 copies, Serials 39  
and 40  
Chief of Ordnance, War Department, SPOTX-AR, Technical Reports, with  
2 copies, Serials 41, 42  
Director of Laboratory, Ordnance Department, Watertown Arsenal,  
Watertown, Mass., with 2 copies, Serials 43, 44  
Director, Technical Information Branch, Laboratory Services, Aberdeen  
Proving Ground, Aberdeen, Md., with 2 copies, Serials  
45 and 46  
Commanding Officer, Engineer Board, Demolition Branch, Fort Belvoir, Va., with 2 copies,  
Serials 47 and 48  
Commandant, U.S. Coast Guard, 1300 E St. N.W., Washington D.C., with 2  
copies, Serials 49 and 50  
Director, National Bureau of Standards, Conn. and Upton St., N. W.,  
Washington D.C., with 2 copies, Serials 51, 52  
Director, Underwater Explosives Research Laboratory, Woods Hole, Mass.  
with 2 copies, Series 53, 54  
Director of Aeronautical Research, National Advisory Committee for  
Aeronautics, 1500 New Hampshire Ave. N.W., Washington, D.C., with 2  
copies, Serials 55, 56  
Director, Geophysical Laboratory, Carnegie Institution, with 1 copy,  
Serial 57  
Commander. E. A. Wright, USN, Charleston Naval Shipyard, Naval Base Q, S.C.  
with 1 copy Serial 58  
Commander. G. C. Manning (CC) USN (Ret), Massachusetts Institute of  
Technology, Cambridge, Mass, with 1 copy, Serial 59  
Dr. T. C. Foulter, Armour Research Foundation, 35 West 33 Street.,  
Chicago 16, Ill., with 1 copy, Serial 60  
Dr. Daniel Silverman, Stanolind Gas and Oil Company, Tulsa, Oklahoma  
with 4 copies, Serials 61, 62, 63, 64

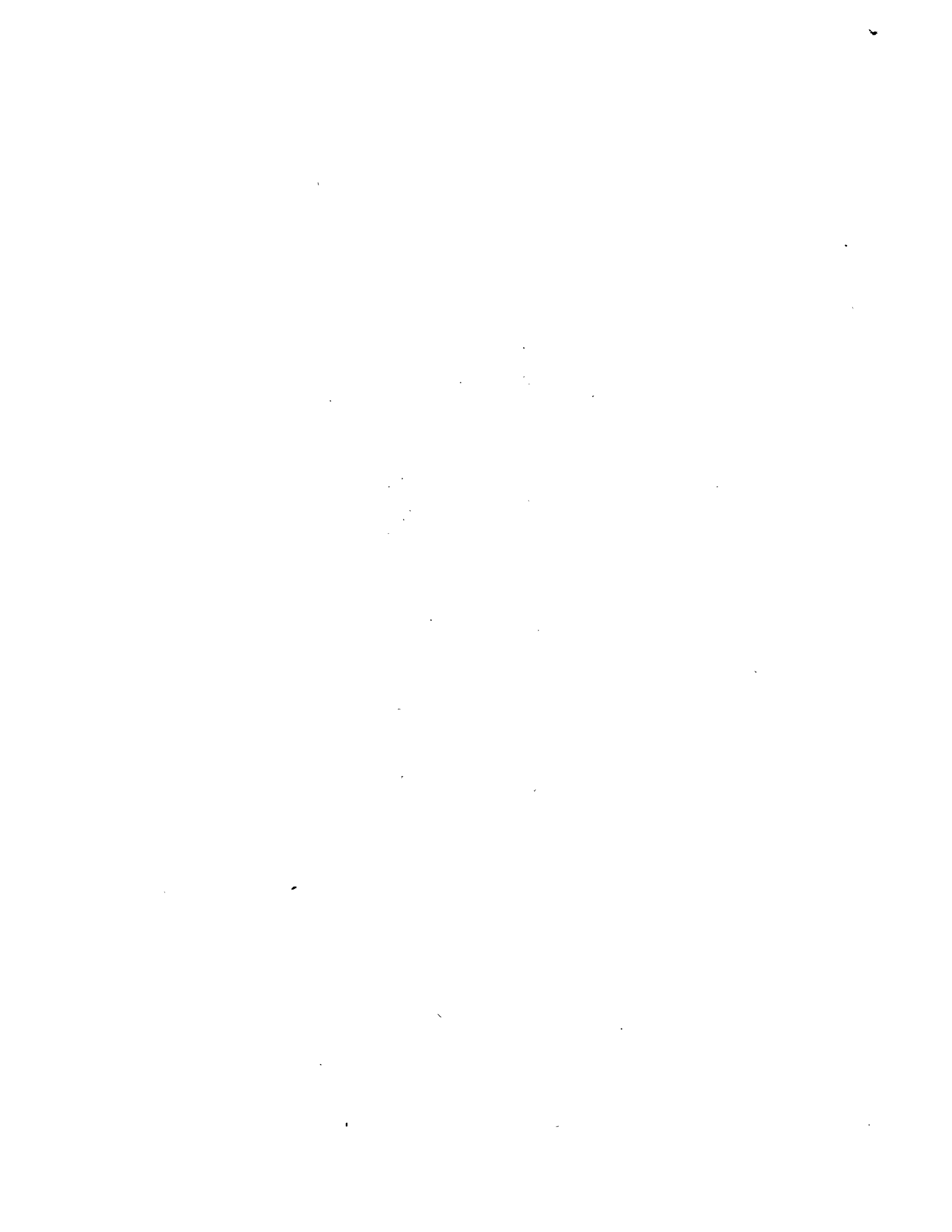

TABLE OF CONTENTS

ABSTRACT . . . . .	page 1
INTRODUCTION . . . . .	1
TEST SETUP AND PROCEDURE . . . . .	2
FIRING ARRANGEMENTS . . . . .	2
TOURMALINE GAGE . . . . .	2
TMB DIAPHRAGM GAGE . . . . .	4
LOCATION OF GAGES . . . . .	8
TEST RESULTS . . . . .	12
ANALYSIS OF DATA . . . . .	28
TIME MEASUREMENTS . . . . .	28
WAVE FORMS . . . . .	28
PEAK PRESSURES . . . . .	31
GENERAL COMMENTS . . . . .	32
CONCLUSIONS . . . . .	32
REFERENCES . . . . .	32





## CONFIDENTIAL

### COMPARATIVE TEST OF THE NDRC TOURMALINE AND THE TMB DIAPHRAGM AIR-BLAST GAGES

#### ABSTRACT

Gages of two types were used simultaneously in measuring the pressure caused by blasts due to the firing of ten rounds from a 3-inch 50-caliber gun, to permit a comparative study of the performance of the two types. Four of the gages were of the tourmaline type developed by the National Defense Research Committee, and three were of the diaphragm type developed by the David Taylor Model Basin.

A general description of the test equipment and procedure is given. The oscillographic test records are reproduced. A comparative analysis is made of the peak pressures, durations, and wave-form characteristics.

The results of the test indicate that the two types of gages are equally practical for blast measurements in air.

#### INTRODUCTION

A diaphragm gage (1)\* has been developed by the David Taylor Model Basin for the measurement of gun-blast and bomb-blast pressures in air. The pressure-sensitive element of the gage consists of a thin, metallic, circular, fixed-edge diaphragm. Applied pressures produce strains in the diaphragm, which are measured by a wire-resistance strain gage cemented to the inner face of the diaphragm.

Various research agencies have been conducting blast tests with piezoelectric gages. In gages of this type, advantage is taken of the electromechanical properties of certain crystals such as tourmaline, quartz, and rochelle salt. If mechanical stresses are suitably applied to these crystals, a separation of charge takes place so that certain regions become positively charged and others negatively charged. The quantity of charge offers a measure of the magnitude of the stresses. It is evident that the piezoelectric gage and the diaphragm gage are based on entirely different principles.

In the analysis of test data a question naturally arises as to the reliability of the results. The consistency of the gages used can easily be checked, but to establish the accuracy of the gages is often a more difficult problem. When an absolute scale for reference is not available, an alternative generally used is comparison of gages of different types.

Based on these considerations, a test comparing the performance of the NDRC tourmaline crystal gage (2) with that of the TMB diaphragm gage was conducted. This test and the results are described here. No attempt is made

---

\* Numbers in parentheses indicate references on page 32 of this report.

in this report to analyze and interpret the qualitative features of the individual records with respect to the gun blast. This will be done in a subsequent report, containing an extensive experimental survey of the blast field around a 3-inch gun.

A separate report on this test has been prepared by the Stanolind group (3).

#### TEST SETUP AND PROCEDURE

The test was conducted on the 3-inch-gun range of the National Defense Research Committee, located on the grounds of the Taylor Model Basin at Carderock, Maryland.

#### FIRING ARRANGEMENTS

Blast pressures were measured in the neighborhood of a 3-inch 50-caliber naval gun. The gun was fired at zero elevation for ten rounds with fixed ammunition consisting of a target projectile weighing 13 pounds and a service powder charge of 3.96 pounds. The center of the gun muzzle was 51 1/2 inches above the ground. The projectiles were fired into a butt located at the far end of the 500-foot gun range (4).

#### TOURMALINE GAGE

The crystal-gage records were taken with a Stanolind mobile four-channel field recording unit. This unit houses all the necessary auxiliary recording equipment.

Each of the four crystal gages (2) used during the test was composed of four tourmaline crystals, about 1 5/8 inch in diameter, electrostatically shielded by fine copper gauze, and coated with layers of Bostik\* and Tygon.\*\* The gage sensitivities were approximately  $95 \times 10^{-12}$  coulomb per pound per square inch pressure.

The gages were coupled to the amplifier circuit with one side of each crystal connected to ground. The gage signals were transmitted by 1000 feet of Copolene† cable and 100 feet of special microphone cable at the gage ends. The total shunt capacitance across each gage was about 0.04 microfarad. At the gage ends the cables were shielded from direct blast pressures by 25-foot lengths of 1-inch steel pipe. The pipe sections were fastened to a

---

\* Bostik is the trade name for a liquid rubber cement manufactured by the B.B. Chemical Company, Cambridge and South Middleton, Mass.

\*\* Tygon is the trade name for a liquid cement manufactured by the U.S. Stoneware Company, Akron, Ohio.

† Copolene cable is a commercially available cable with a plastic dielectric as insulation between the conductor and the shield.

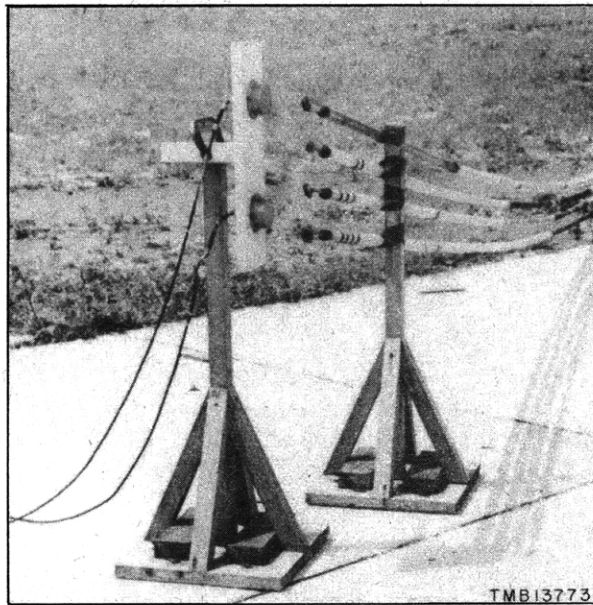

Figure 1a - General Gage Setup

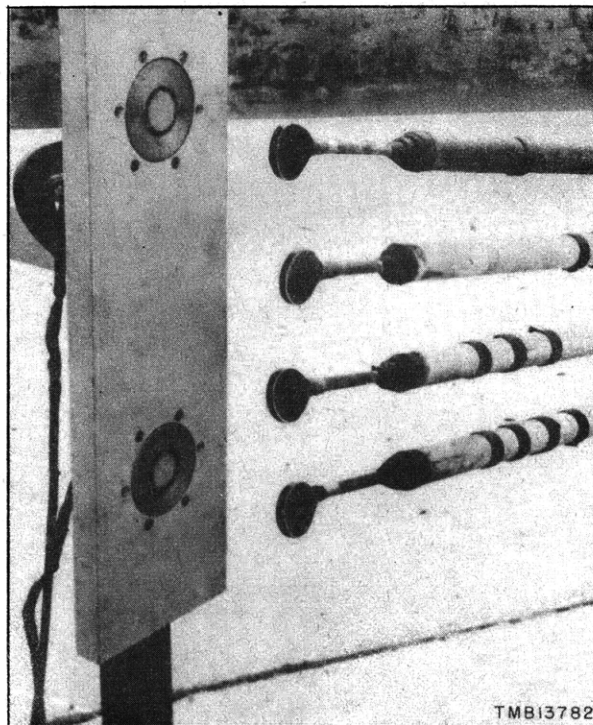

Figure 1b - Close-Up View of Gages

The protecting caps have been removed from the diaphragm gages.

### Figure 1 - Relative Positions of Gages Mounted for Rounds 3 to 10

The diaphragm gages on the stand at the left are covered with caps for protection against accidental damage between rounds. The 25-foot lengths of steel pipe behind each of the tourmaline gages carry the gage cables and protect them against direct blast effects. Two 27-pound weights are fixed to the base of each gage stand to increase its inertia.

wooden supporting stand which had two 27-pound weights fixed to its base. The gage setup is shown in Figure 1.

The gage signals were recorded on cathode-ray oscillographs. A sweep circuit was triggered by the gun blast breaking a contactor circuit located several feet nearer to the gun than were the gages. The cathode-ray spot was swept across the screen horizontally from left to right, and the beam trace was photographed on 35mm film. Timing pulses and step-calibration signals were superimposed on the same film by successive exposures.

#### TMB DIAPHRAGM GAGE

The basic theory and the details of construction of the diaphragm gage have been discussed in an earlier report (1). The modifications that have since been introduced will be reported here.

The operation of the diaphragm gage is based on the elastic deformation of the diaphragm by an unbalance between the pressures acting on the outer and the inner surfaces. A problem encountered in the early stages of development of the gage was that of preventing back pressure from developing on the inner surface of the diaphragm. This problem was solved by the introduction of airtight seals. This back pressure has been completely eliminated in the present design of the gage body. A cross-sectional diagram of the present gage, designated as Model C, is shown in Figure 2.

Diaphragm gages of this type were used during the test. The diaphragms of the gages were 1/2 inch in diameter. Two of the gages used, numbered 4 and 11, had pressure sensitivities of about 0.01 ohm per pound per square inch and a natural frequency of 20,000 cycles per second. A third gage

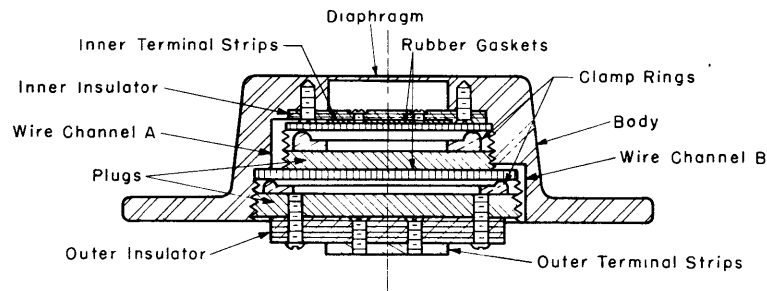

Figure 2 - Sectional View of Model-C TMB Diaphragm Gage

The connecting leads of the gage are brought out through the wire channels A and B and are soldered to the outer terminal strips. The two rubber gaskets and clamp rings form airtight seals. As an added precaution a thin layer of Alaka\* lacquer is applied to the outer rim of the screw-plug joints. A light coat of the lacquer is also applied over the entire outer surface of the gage as a protection against corrosion.

\* Alaka is the trade name for a blue-gray lacquer manufactured by the Lacquer and Chemical Corporation, Brooklyn, N.Y.

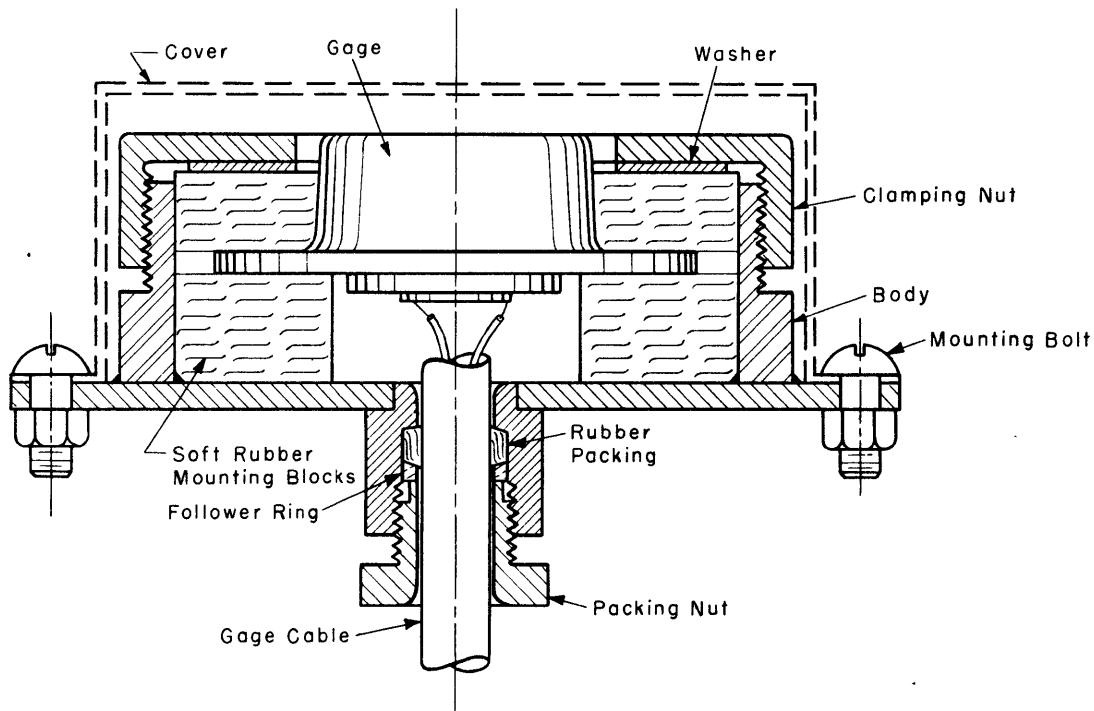

Figure 3 - Housing of the TMB Diaphragm Gage

used during the early part of the test, numbered A8, had a sensitivity of about 0.005 ohm per pound per square inch and a natural frequency of 30,000 cycles per second. To check sensitivity factors, the gages were recalibrated immediately after the test.

A photograph of the front of the special shockproof housing used for mounting the gages is shown in Figure 1; a diagram of the housing is shown in Figure 3. The gage is completely insulated from the casing by soft rubber mounting blocks, which protect it against high-frequency vibrations. The gage and housing form an integral unit which need not be taken apart.

A new amplifier-filter unit, designed by G.W. Cook of the Electronics Section of the Taylor Model Basin, was used as part of the recording apparatus. Figure 4 is a schematic diagram of this unit. The amplifier has a gain factor of about 125 and a very low noise level. The purpose of the filter circuit is to eliminate electrically the gage signals corresponding to the free vibrations of the diaphragm excited by the abrupt pressure rise in the blast waves.

The gage signals were recorded by two DuMont Type-208 cathode-ray oscillographs and a rotating drum camera. The drum was 18 inches in diameter and rotated at a speed of about 600 RPM. The film used was Eastman Super XX, 3 5/8 inches in width and approximately 5 feet in length. Two oscillograph channels were recorded on each film, with the beams passing through

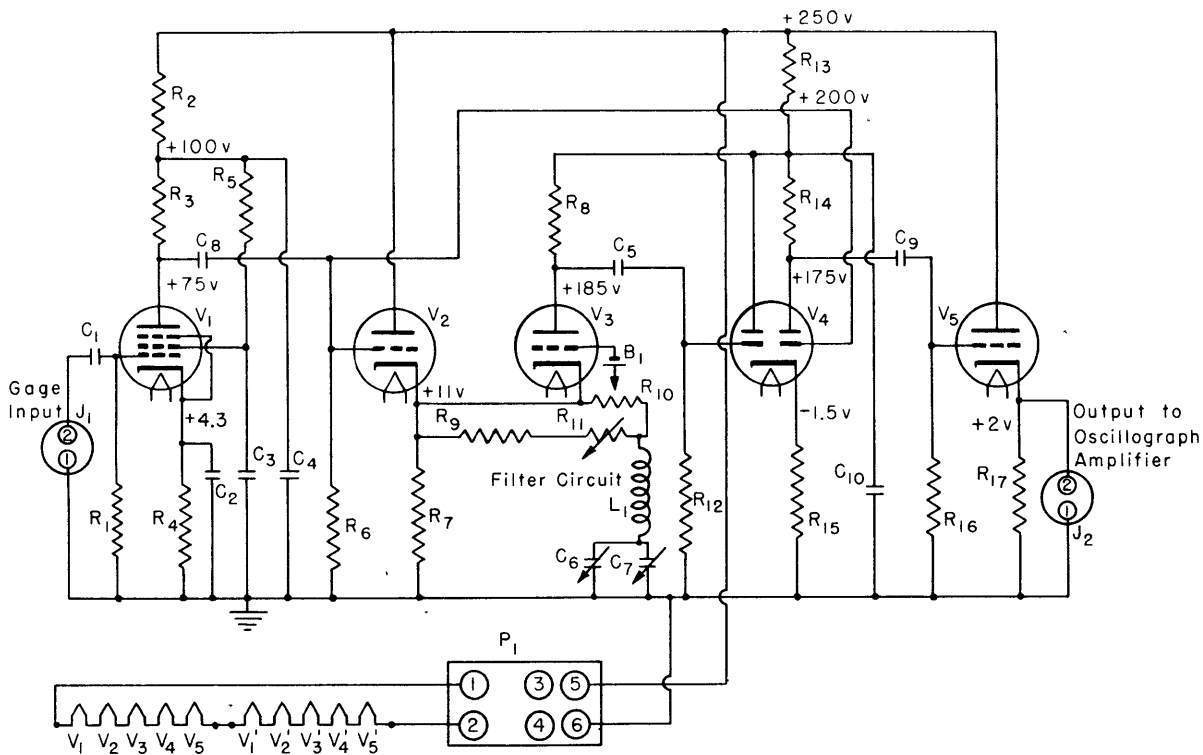

Figure 4 - Circuit of TMB Amplifier-Filter Unit

Two channels of the electronic filter are built in one cabinet and supplied from one regulated power supply, Type 5-A. The heaters of all tubes in both channels are connected in series and heated with 130-milliampere direct current from the power supply.

Parts List

- |  |  |               |
|--|--|---------------|
| $R_1$ - 1 M, 1/2 w                                   | $R_{10}$ - 100 K potentiometer                       | $V_1$ - 12SJ7 |
| $R_2$ - 200 K, 1 w                                   | $R_{11}$ - 500 K potentiometer                       | $V_2$ - 12J5  |
| $R_3$ - 30 K, 1 w                                    | $R_{12}$ - 1/2 M, 1/2 w                              | $V_3$ - 12SF5 |
| $R_4$ - 6 K, 1 w                                     | $R_{13}$ - 10 K, 1 w                                 | $V_4$ - 12SC7 |
| $R_5$ - 50 K, 1 w                                    | $R_{14}$ - 20 K, 1 w                                 | $V_5$ - 12SP5 |
| $R_6$ - 1 M, 1/2 w                                   | $R_{15}$ - 400 ohms, 1 w                             |               |
| $R_7$ - 2.5 K, 1 w                                   | $R_{16}$ - 1 M, 1/2 w                                |               |
| $R_8$ - 12.5 K, 1 w                                  | $R_{17}$ - 2 K, 1 w                                  |               |
| $R_9$ - 1 K, 1 w                                     |  |               |
| $C_1$ - 0.5 $\mu$ f, 600 v, Cornell-Dubilier Dykanol | $C_9$ - 0.5 $\mu$ f, 600 v, Cornell-Dubilier Dykanol |               |
| $C_2$ - 2000 $\mu$ f, 6 v, electrolytic              | $C_{10}$ - 80 $\mu$ f, 450 v, electrolytic           |               |
| $C_3$ - 8 $\mu$ f, 450 v, electrolytic               | $J_1$ - Amphenol chassis connector PC2F              |               |
| $C_4$ - 4 $\mu$ f, 450 v, electrolytic               | $J_2$ - Amphenol chassis connector PC2F              |               |
| $C_5$ - 0.5 $\mu$ f, 600 v, Cornell-Dubilier Dykanol | $L_1$ - R.F. choke, 25 ohms                          |               |
| $C_6$ - 0.0001 to 0.002 $\mu$ f, Decade              | $B_1$ - Mallory grid bias cell, 1 v                  |               |
| $C_7$ - 0 to 140 $\mu$ f, Variable                   | $P_1$ - 6-Prong Jones plug S306 - RP                 |               |
| $C_8$ - 0.5 $\mu$ f, 600 v, Cornell-Dubilier Dykanol |  |               |

Note: K corresponds to a multiplying factor of  $10^3$ . M corresponds to a multiplying factor of  $10^6$ . The unit of all resistances is ohms.

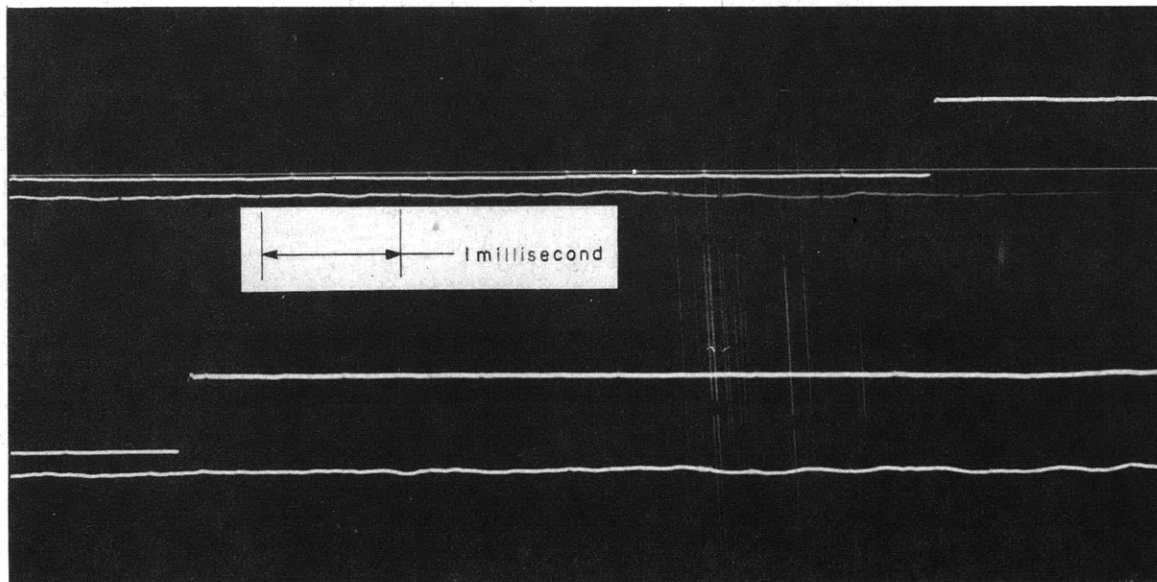

Figure 5 - Sample Record of Calibration Step Pulses

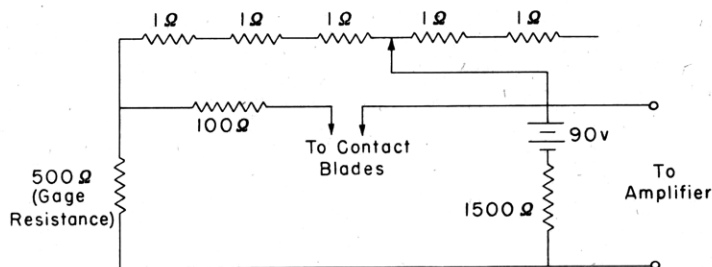

Figure 6 - Ballast Circuit Modified for Calibration Signals

The calibration step pulse is developed when the contact between the blades is broken. The signals were recorded by synchronizing the shutter mechanism with the dropping of a weight which broke the contact.

individual f2.5 lenses of about 50mm focal length. The recording reduction was roughly 3 to 1 in amplitude. The shutter, whose mechanism was synchronized with the firing of the gun, opened shortly after the gun was fired and remained open for 1 revolution.

The time resolution of the film was determined by recording continuously on each oscillograph a series of pulses that occurred at intervals of 1 millisecond. The timing pulses were initiated by a 1000-CPS tuning fork. The pulse width was about 15 microseconds and the height was kept small to avoid interference with the gage record.

The pressure amplitude scale was calibrated by recording a step pulse on the same film as the gage records. This step pulse corresponded to a known resistance change in the gage-input circuit. A sample calibration record is shown in Figure 5, and a diagram of the ballast circuit in Figure 6.

Except for the ballast circuit and amplifier-filter unit, the recording equipment used was all part of the regular facilities of the NDRC gun-range laboratory which were made available for the test. The operation of this equipment is described fully in a report on the interior-ballistics measurements conducted by the National Bureau of Standards (4).

#### LOCATION OF GAGES

The gages were located with reference to a polar-coordinate grid which had been painted on the concrete slab beneath the gun for an earlier blast test. The location of the gage stations for the ten rounds of the present test is indicated in Table 1 and Figure 7.

For the first two rounds of the test, in both of which the setup was the same, the relative positions of the tourmaline and the diaphragm gages were as shown in Figure 8. The diaphragm gages were placed face up and horizontal, whereas the tourmaline gages were placed with the gage faces vertical and parallel to a line extending from the center of the gun muzzle to the gage.

The records for these two rounds indicated that the orientation of the diaphragm gages was not satisfactory for a suitable comparison of the two types of gages. Because of the face-up position of the diaphragm gages a diffraction effect was introduced in the recording of the blast wave reflected

TABLE 1

Distribution of Gages for Each of the Rounds

Round	Gages		$\alpha^*$ degrees	$d^{**}$ feet
	Tourmaline	Diaphragm		
1	2	1	15	21
2	2	1	30	21
3	2	1	15	21
4	3	2	30	21
5	3	2	30	21
6	4	2	30	18
7	4	2	60	15
8	4	2	60	12
9	4	2	90	9
10	4	2	60	9
			30	12

\*  $\alpha$  is the angle between the horizontal vector  $d$  and the line of fire; see Figure 9.

\*\*  $d$  is the length of the horizontal component of the radius vector extending from the gage to the center of the gun muzzle.



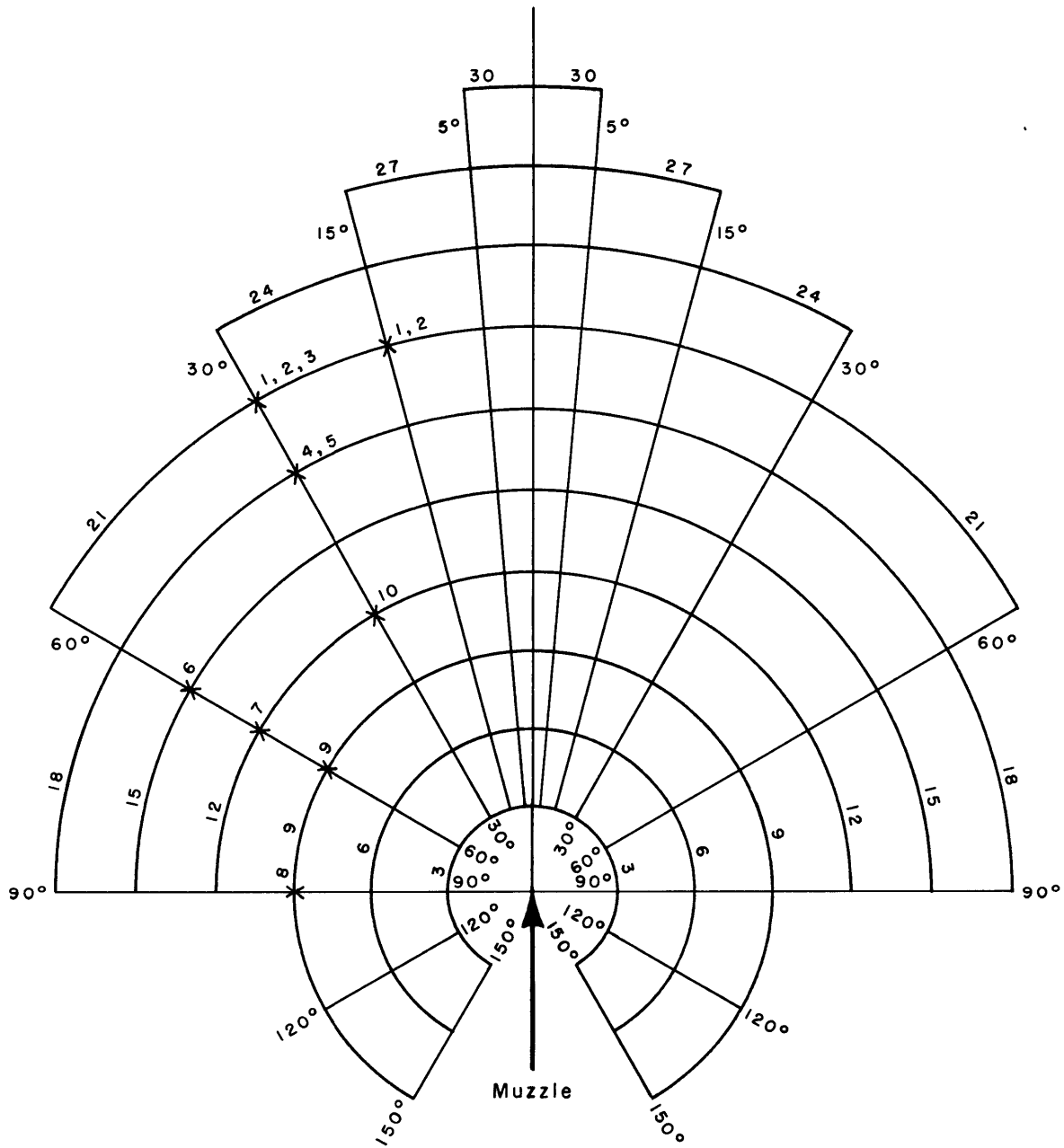

**Figure 7 - Polar Coordinate Grid Used for Location of Gages**

The gage stations for the respective rounds are indicated by cross marks. For Rounds 1 and 2 the gages were divided between two positions; for the remaining rounds the gages were all located together.

The figures along the concentric arcs are radii from the muzzle, in feet.

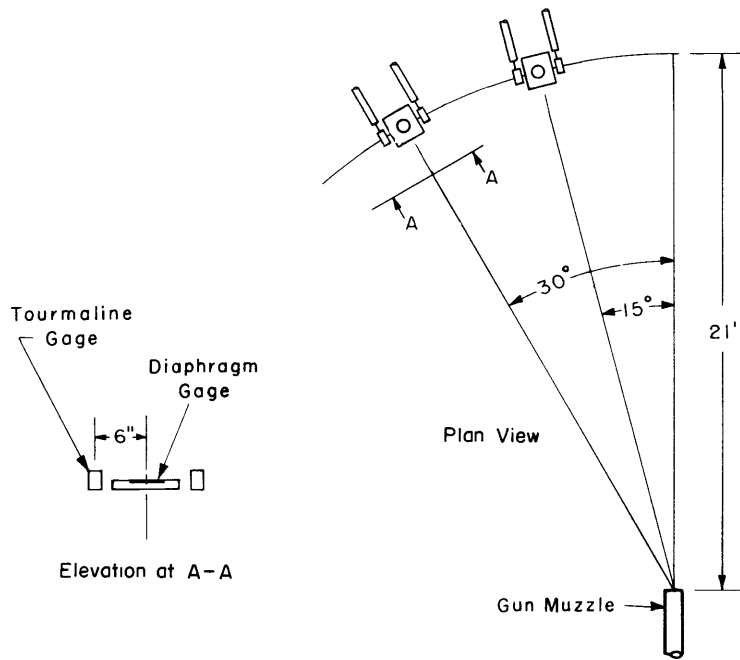

Figure 8 - Gage Positions for Rounds 1 and 2  
 The height of the gages above the concrete slab was 49 inches.

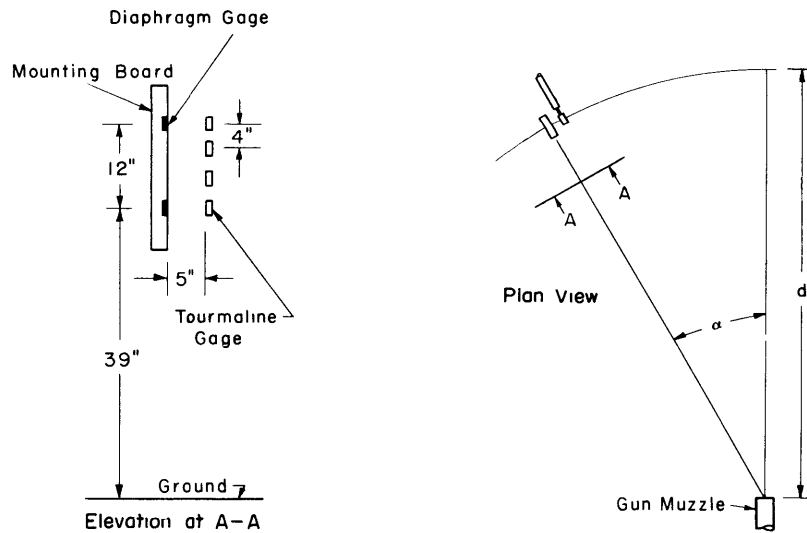

Figure 9 - Gage Positions for Rounds 3 through 10  
 See Table 1 for values of  $\alpha$  and  $d$ .

from the ground, which followed closely the direct wave at the particular gage stations. A similar effect was naturally not present on the tourmaline records. Therefore it was considered advisable for the remainder of the test to orient the diaphragm gages in the same manner as the tourmaline gages,

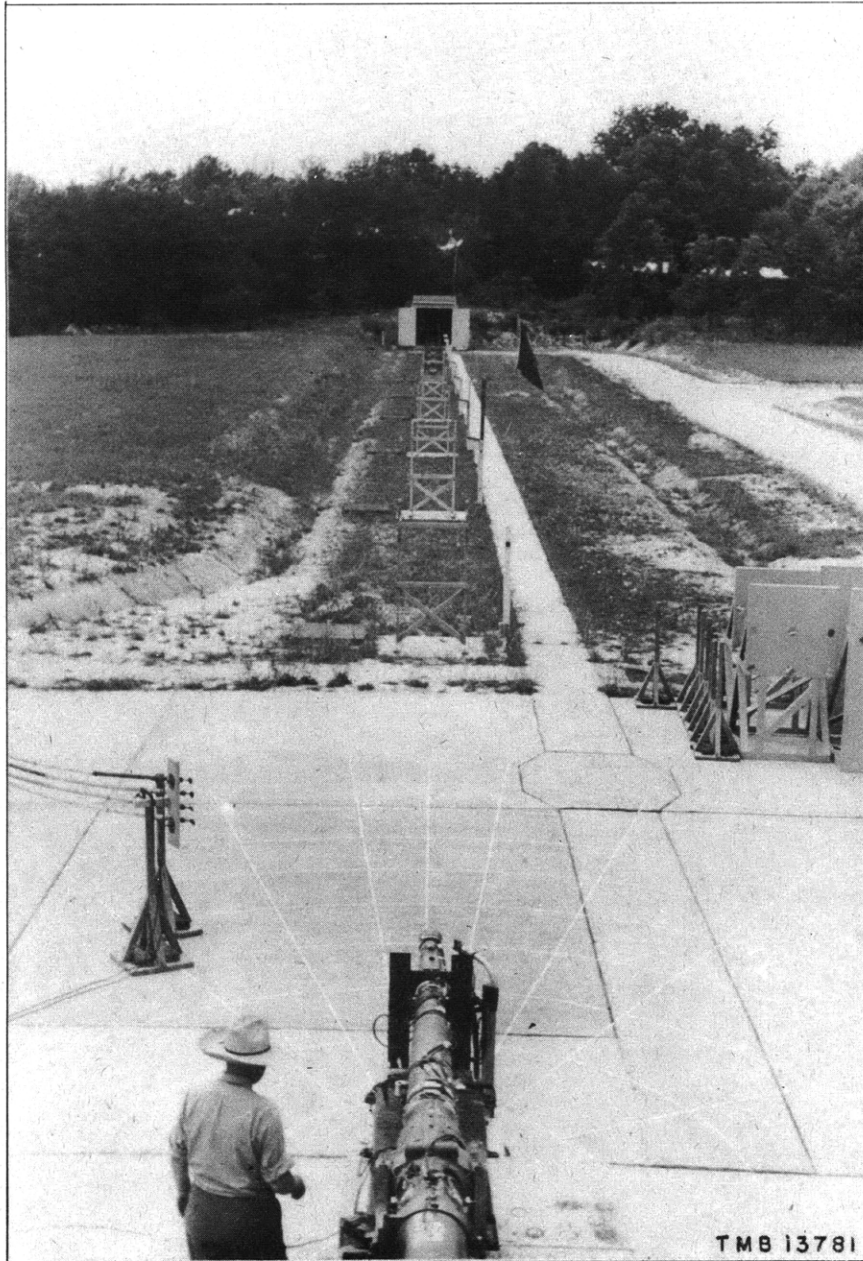

Figure 10 - Photograph of Test Setup for Round 10

This photograph was taken from over and behind the gun in the direction of fire.

namely, with gage faces vertical and parallel to a line extending from the center of the gun muzzle to the gage.

Figure 9 is a sketch of the relative gage positions for Rounds 3 through 10. The four tourmaline gages were placed directly above each other

and were numbered A, B, C, and D in the order of decreasing height. One diaphragm gage was located opposite Tourmaline Gage A, and directly beneath it was the second diaphragm gage opposite Tourmaline Gage D.

A photograph of the experimental setup for Round 10 is shown in Figure 10.

TEST RESULTS

In analyzing the gage data, three main features of the records were examined, namely, peak pressures, durations, and wave forms.

As a preliminary step in presenting the test results, Figure 11 shows records of Diaphragm Gage 4 taken simultaneously with two different sets of recording equipment to determine whether there were any inherent differences

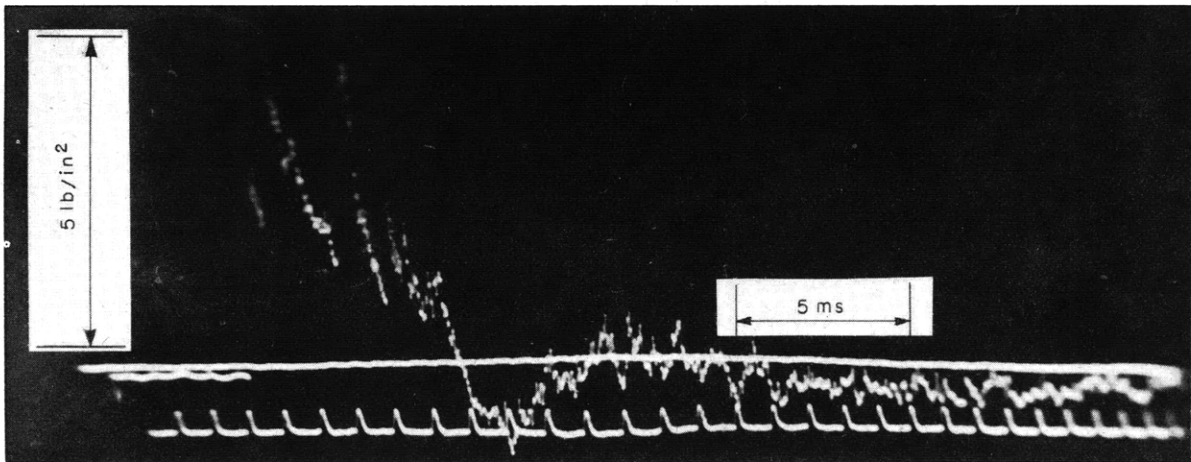

Figure 11a - Record Taken with Stanolind Recording Unit

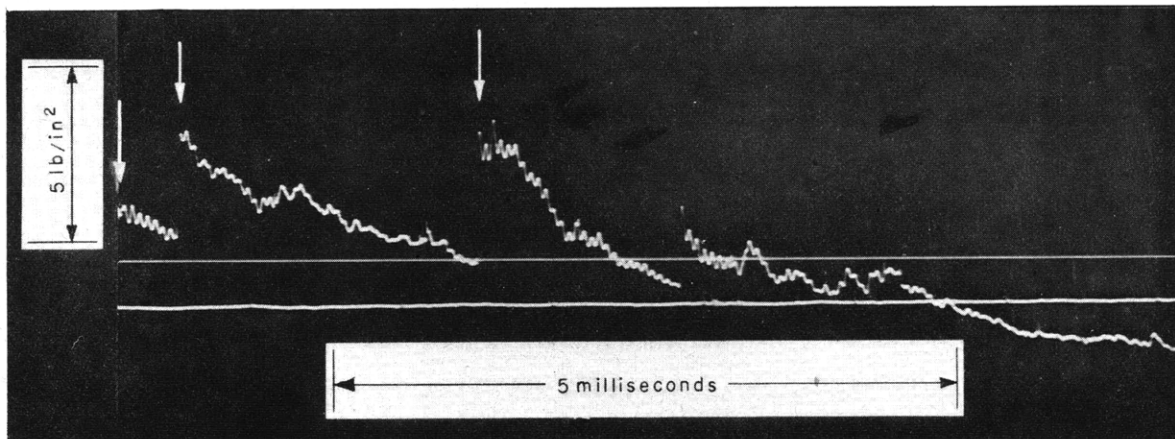

Figure 11b - Record Taken with Taylor Model Basin Recording Unit

This is only a portion of the complete record which was compared with the record of Figure 11a.

Figure 11 - Records of Diaphragm Gage 4 for Round 4

TABLE 2

## Comparison of Peak Pressure and Duration Data

These data were taken by the tourmaline and the diaphragm gages for Rounds 4 through 10.

Round	Tourmaline Gage	Diaphragm Gage	Peak Pressure, pounds per square inch						Duration Time between Pulse 1 and Pulse 2		Duration Time between Pulse 2 and Pulse 3		Duration of Positive Pressure $\tau$ milliseconds	
			Pulse 1		Pulse 2		Pulse 3		Tourma- line	Dia- phragm	Tourma- line	Dia- phragm	Tourma- line	Dia- phragm
			Tourma- line	Dia- phragm	Tourma- line	Dia- phragm	Tourma- line	Dia- phragm						
4	A - C D	A8		2.97		4.03		4.65		0.70		1.59		6.05
		4	3.09	3.29	5.29 5.14	4.35 5.46	4.16	5.06	0.4	0.39	1.7 2.0	1.96	4.8 5.8	5.73
5	A B C D	11	3.47 4.37	4.59	5.88 7.03	6.76			0.5 0.3	0.50			6.3 6.2	6.45
		4	3.45 4.09	3.98	6.45 7.67	6.82			0.25 0.2	0.29			6.1 5.6	6.18
6	A B C D	11	3.11 3.24	4.35	2.64 2.68	2.99	3.67 4.08	5.84	1.4 1.1	1.29	4.6 4.3	4.37	7.5 7.5	7.05
		4	3.10 3.30	3.70	2.76 3.30	3.34	4.39 4.68	6.33	1.0 0.9	0.79	4.2 4.1	4.59	6.8 6.8	7.23
7	A B C D	11	5.29 5.71	6.12	4.41 3.97	4.29			2.2 1.7	1.96			4.5 4.7	5.18
		4	4.48 4.51	5.89	3.96 4.74	5.55			1.5 1.4	1.34			4.0 4.2	5.00
8	A B C D	11	3.70 3.74	4.82	4.29 4.26	6.19			2.6 2.3	2.52			5.1 5.0	5.14
		4	3.58 3.61	4.48	4.00 3.84	4.56			2.0 2.2	1.95			4.8 4.9	5.04
9	A B C D	11	6.45 6.46	7.95	5.46 4.67	9.29			4.6 4.4	4.37			5.2 5.1	5.57
		4	6.82 6.71	8.24	4.16 4.58	7.49			4.6 4.5	4.57			5.2 5.1	5.25
10	A B C D	11	6.58 6.64	8.19	8.97 8.70	9.75			1.7 1.7	1.82			5.6 5.6	6.07
		4	6.60 6.49	8.26	9.90 9.13	10.26			1.3 1.6	1.48			4.4 5.1	5.68

in the records due to the recording technique. The Stanolind recording unit was used for Figure 11a and the Taylor Model Basin recording unit for Figure 11b. Only the gage signal from the ballast box was common to both circuits. As far as could be detected, no important effects were introduced by the different recording techniques.

The test records for Rounds 4 through 10 are reproduced in Figures 12 through 18. The scale of enlargement was arbitrarily chosen so that the pressure scales of the two types of records were approximately equal. The records for Rounds 1 and 2 were not included because of the diffraction effect discussed in the section on "Location of Gages." The diaphragm-gage records for Round 3 were not satisfactory for comparison because of a synchronization difficulty in the shutter mechanism of the drum camera.

The values of peak pressure and duration are given in Table 2. The measurements were made from 6-inch by 9-inch enlargements of the original records. The small white arrows on the diaphragm-gage records, Figures f in Figures 12 to 18 inclusive, indicate the pressure peaks used in the comparison. For Rounds 4 and 6 an analysis was included in the table for a third

(Text continued on page 28)

Figure 12a - Tourmaline Gage A  
No Record

Figure 12b - No Gage

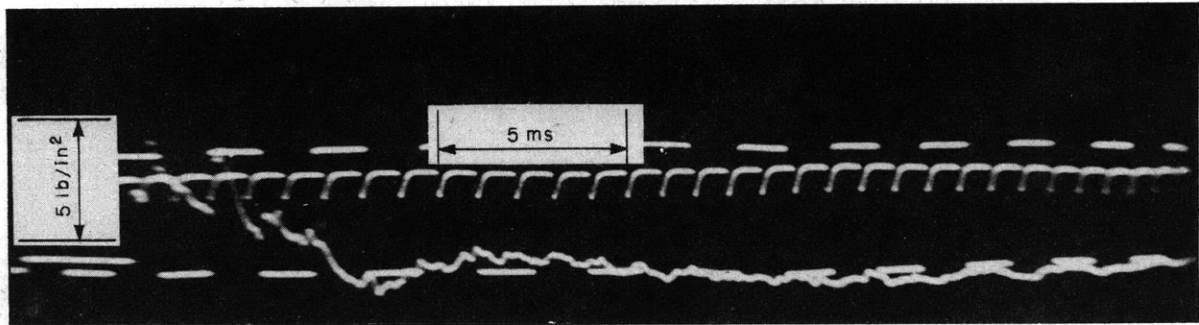

Figure 12c - Record of Tourmaline Gage C

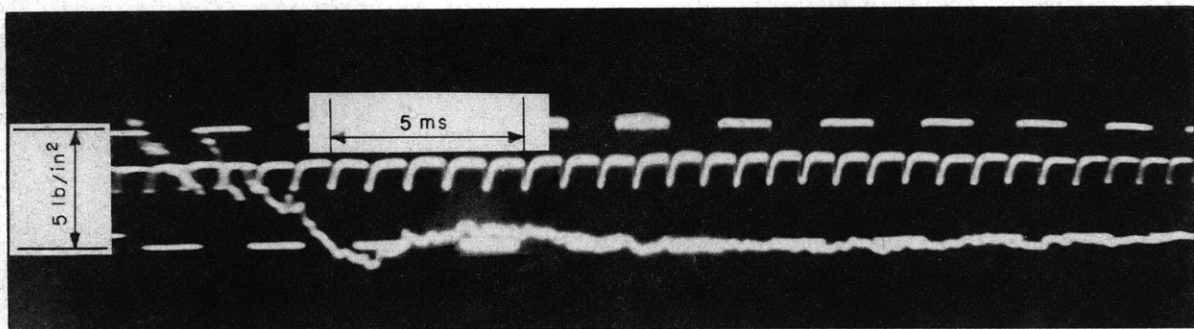

Figure 12d - Record of Tourmaline Gage D

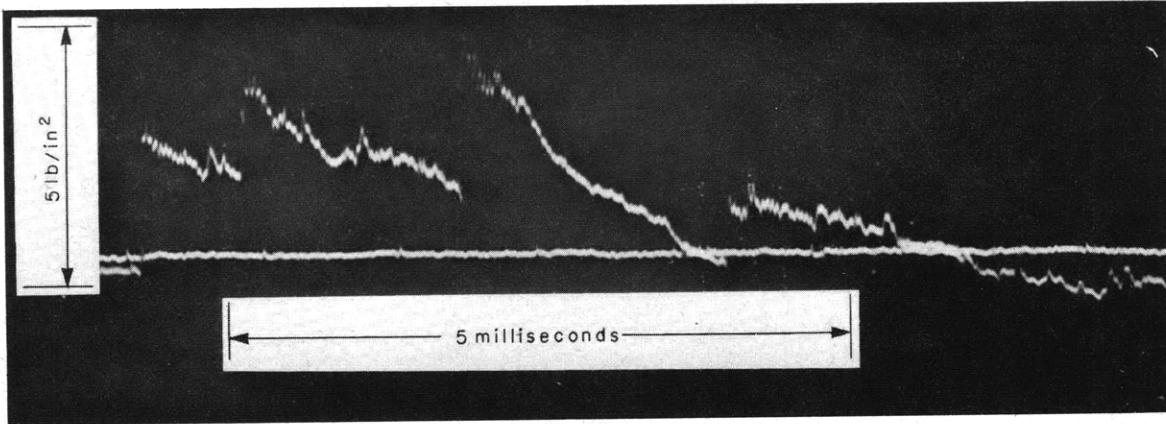

Figure 12e - Record of Diaphragm Gage A8

#### Figure 12 - Test Record, Round 4

For easy comparisons, the records for Round 4 on this pair of pages and the records following for Rounds 5 through 10 are arranged according to the gage locations as shown in Figures 1b and 9. The arrows of Figure 12f indicate the pressure pulses analyzed for the comparison made in Table 2.

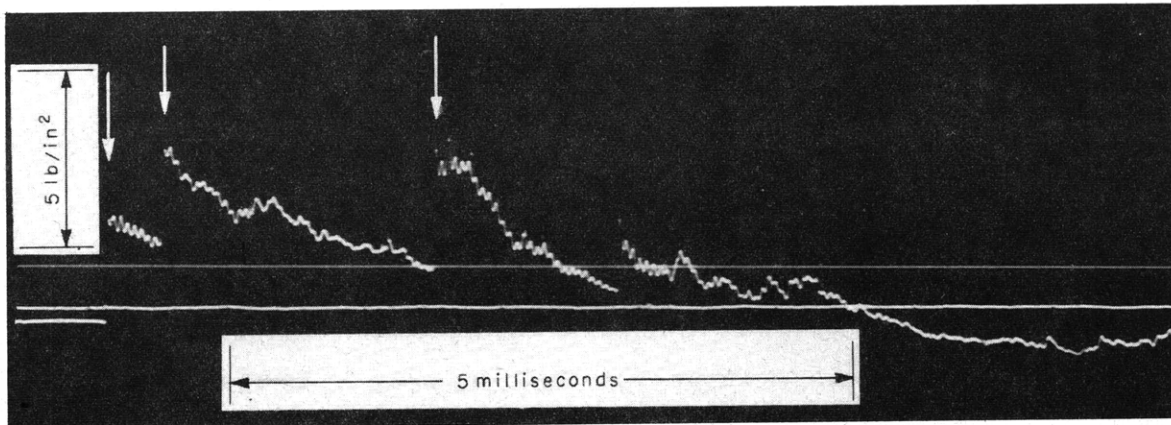

Figure 12f - Record of Diaphragm Gage 4

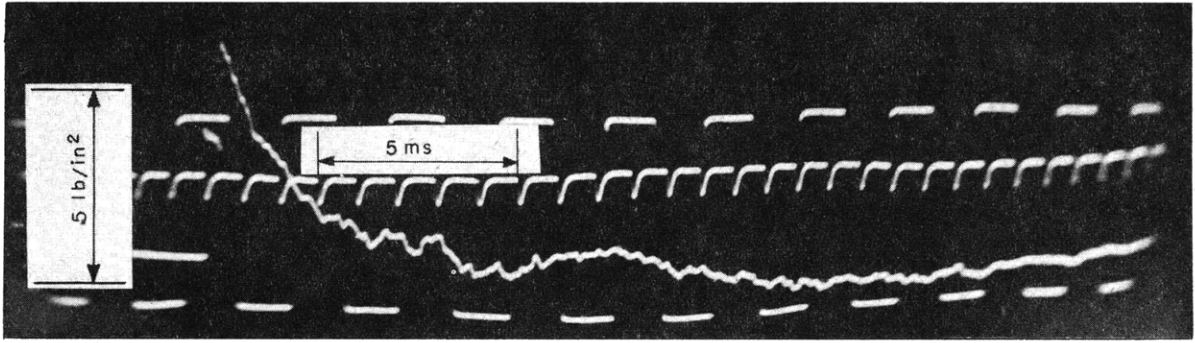

Figure 13a - Record of Tourmaline Gage A

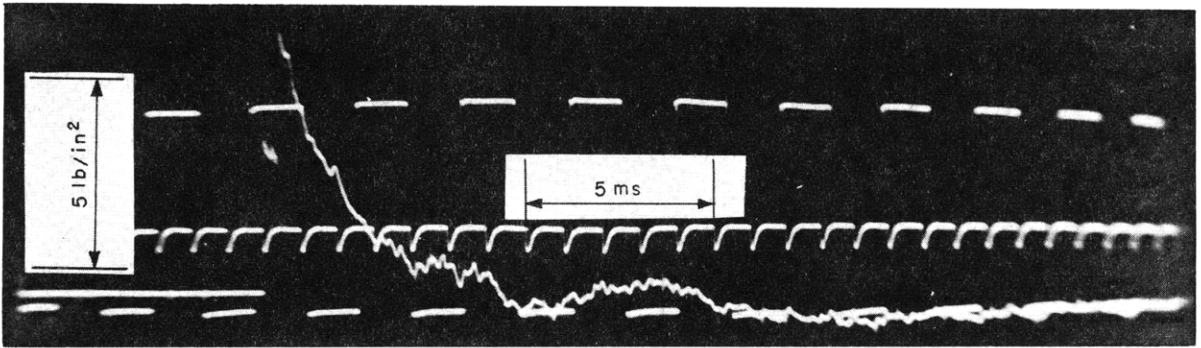

Figure 13b - Record of Tourmaline Gage B

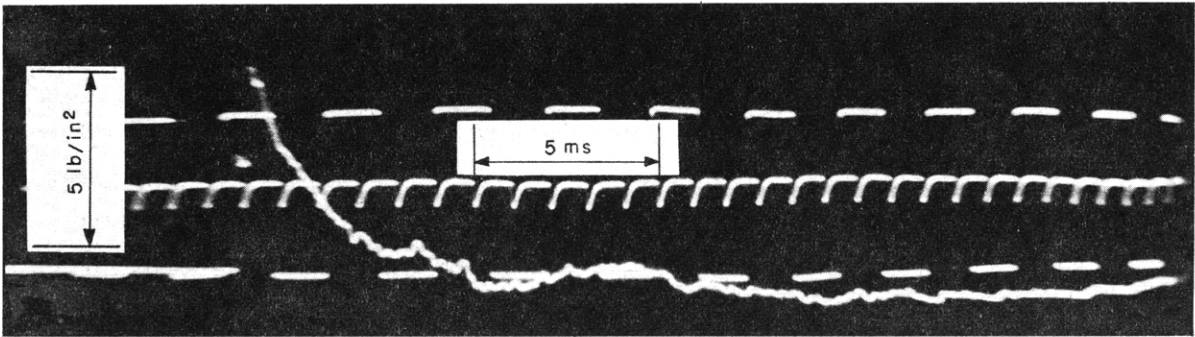

Figure 13c - Record of Tourmaline Gage C

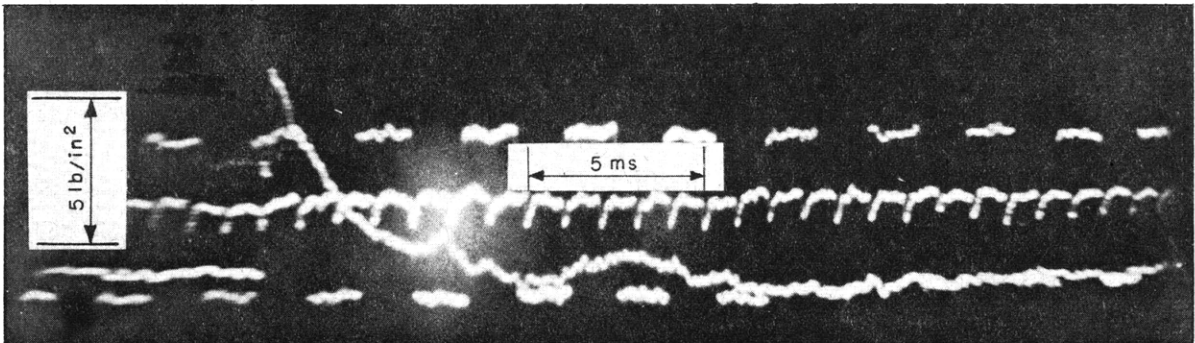

Figure 13d - Record of Tourmaline Gage D



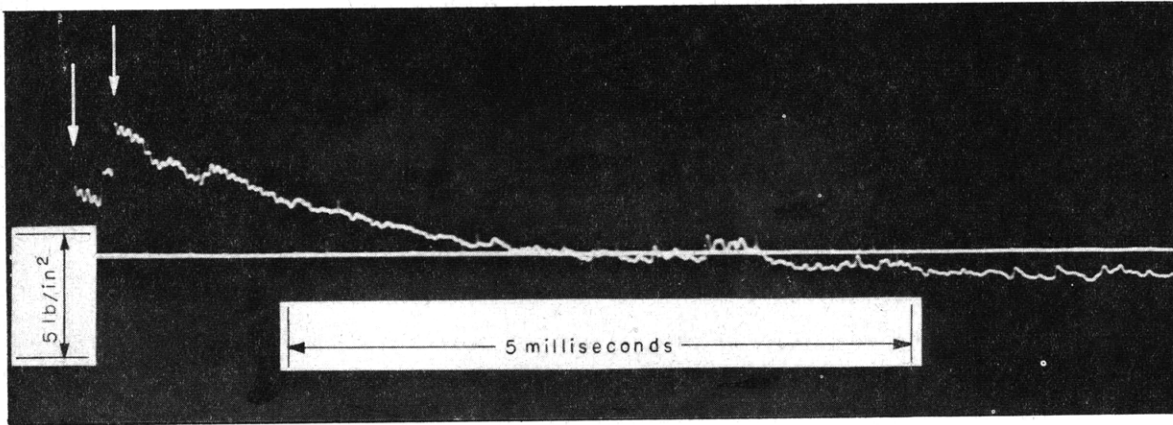

Figure 13e - Record of Diaphragm Gage 11

### Figure 13 - Test Record, Round 5

The arrows of Figure 13f indicate the pressure pulses analyzed for the comparison made in Table 2.

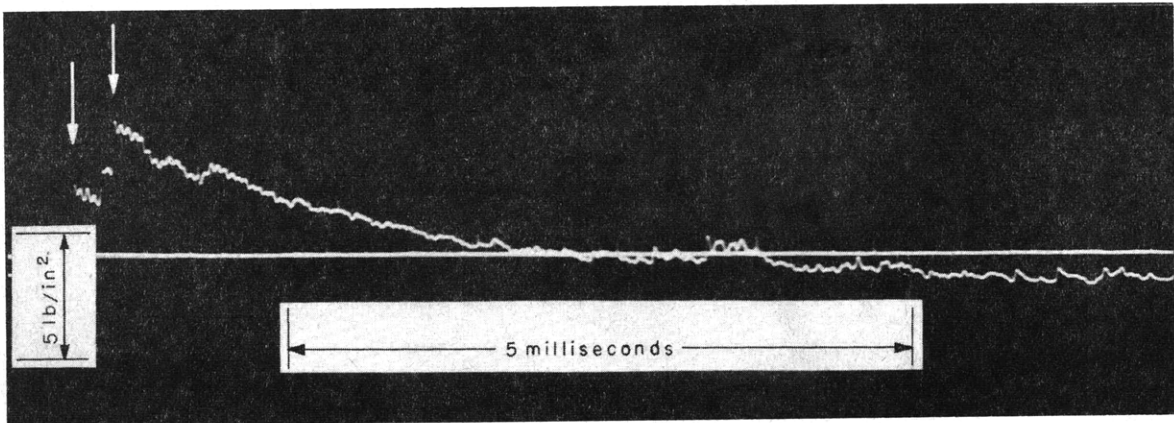

Figure 13f - Record of Diaphragm Gage 4

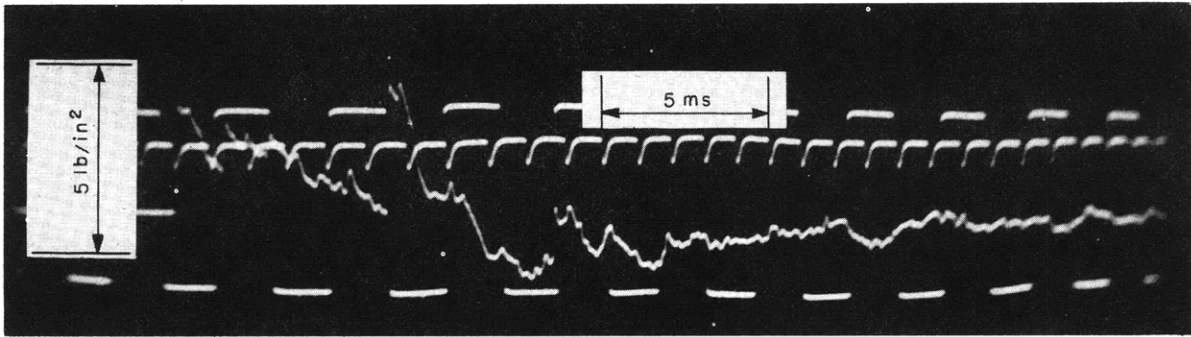

Figure 14a - Record of Tourmaline Gage A

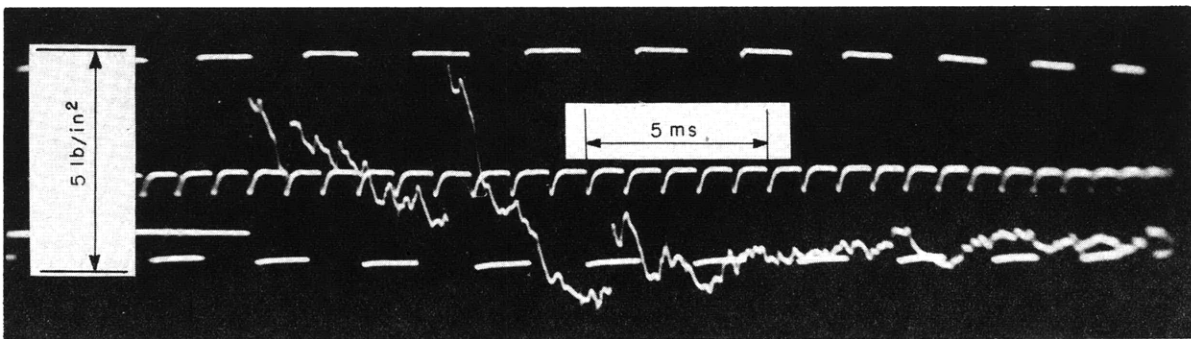

Figure 14b - Record of Tourmaline Gage B

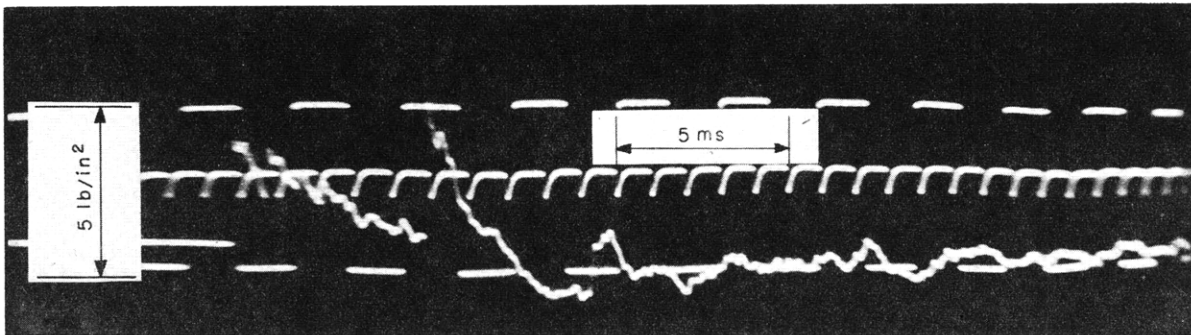

Figure 14c - Record of Tourmaline Gage C

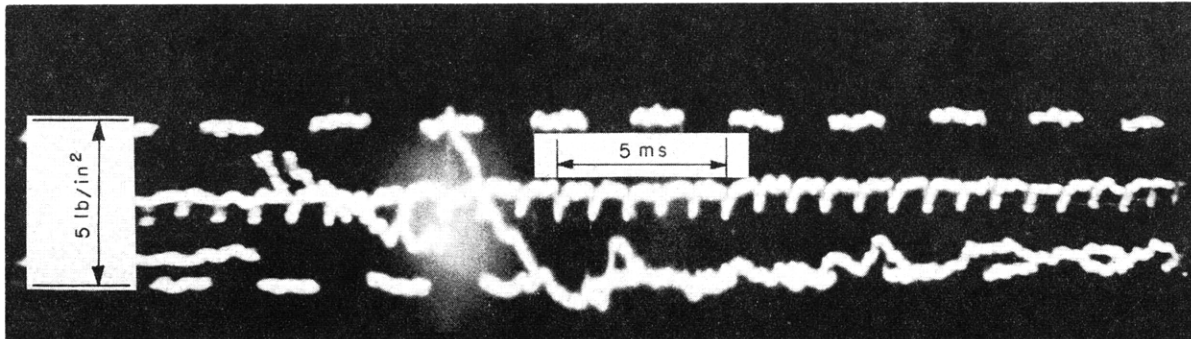

Figure 14d - Record of Tourmaline Gage D

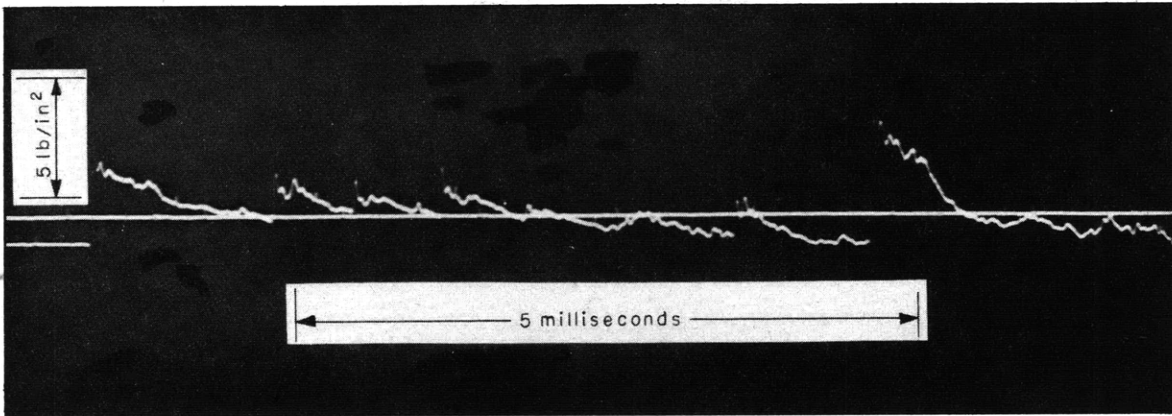

Figure 14e - Record of Diaphragm Gage 11

Figure 14 - Test Record, Round 6

The arrows of Figure 14f indicate the pressure pulses analyzed for the comparison made in Table 2.

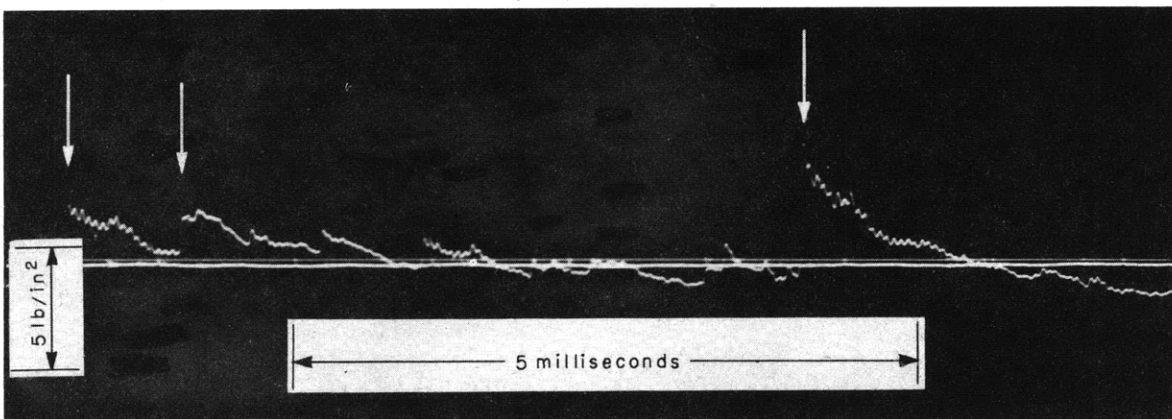

Figure 14f - Record of Diaphragm Gage 4

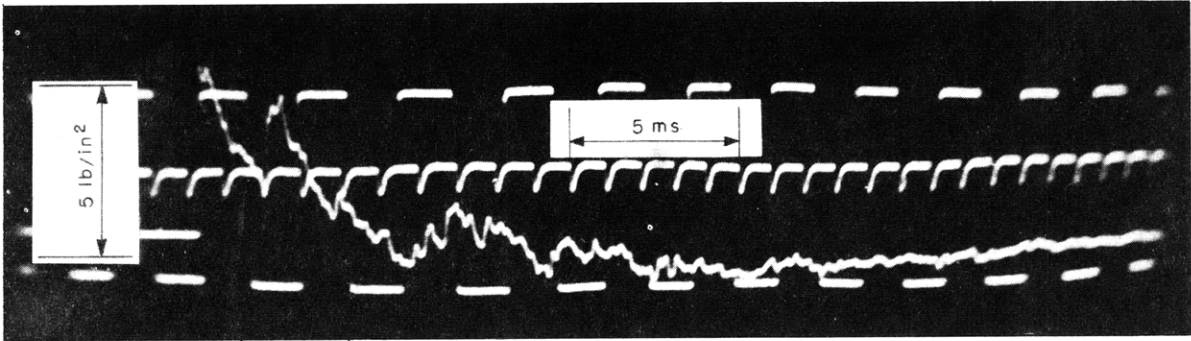

Figure 15a - Record of Tourmaline Gage A

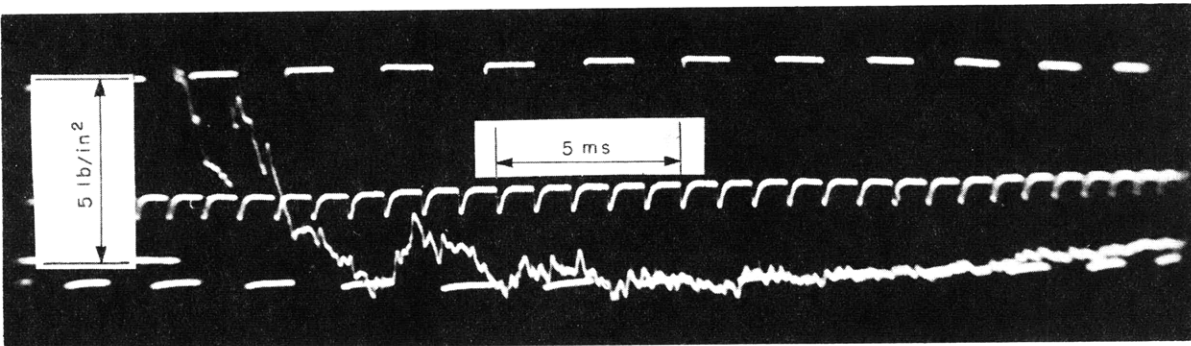

Figure 15b - Record of Tourmaline Gage B

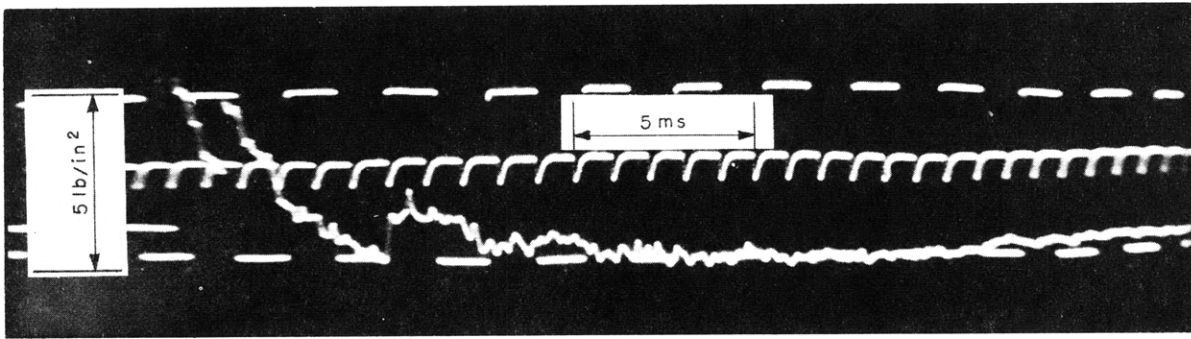

Figure 15c - Record of Tourmaline Gage C

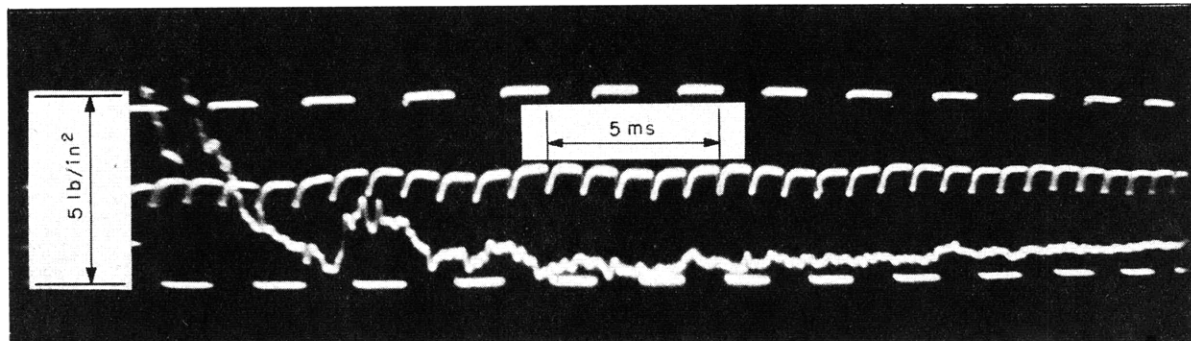

Figure 15d - Record of Tourmaline Gage D

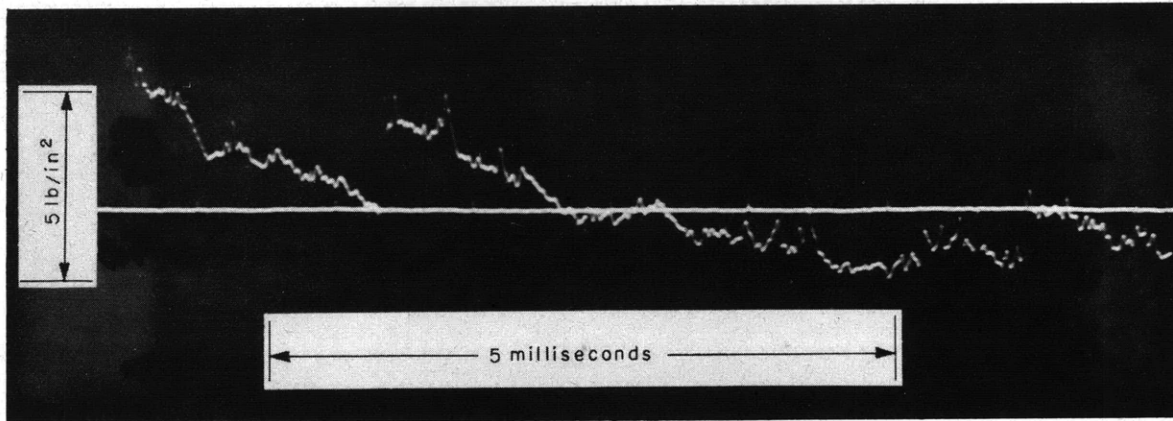

Figure 15e - Record of Diaphragm Gage 11

Figure 15 - Test Record, Round 7

The arrows of Figure 15f indicate the pressure pulses analyzed for the comparison made in Table 2.

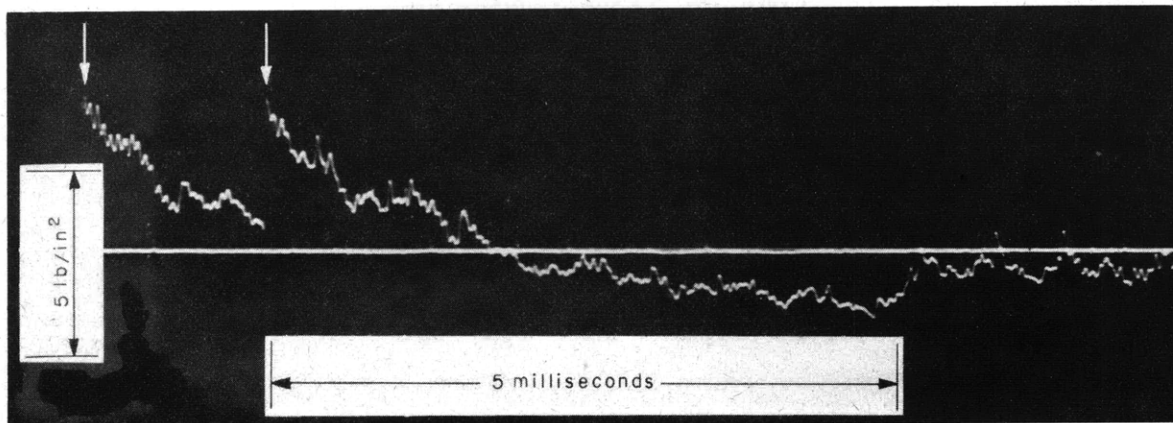

Figure 15f - Record of Diaphragm Gage 4

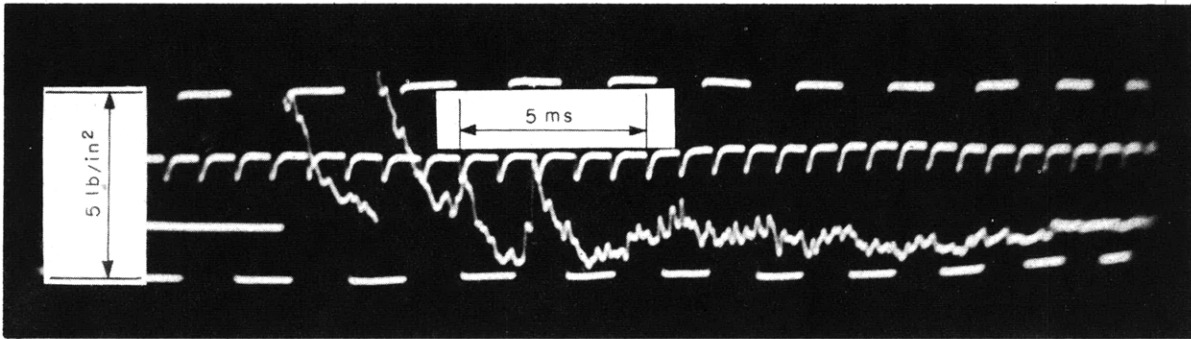

Figure 16a - Record of Tourmaline Gage A

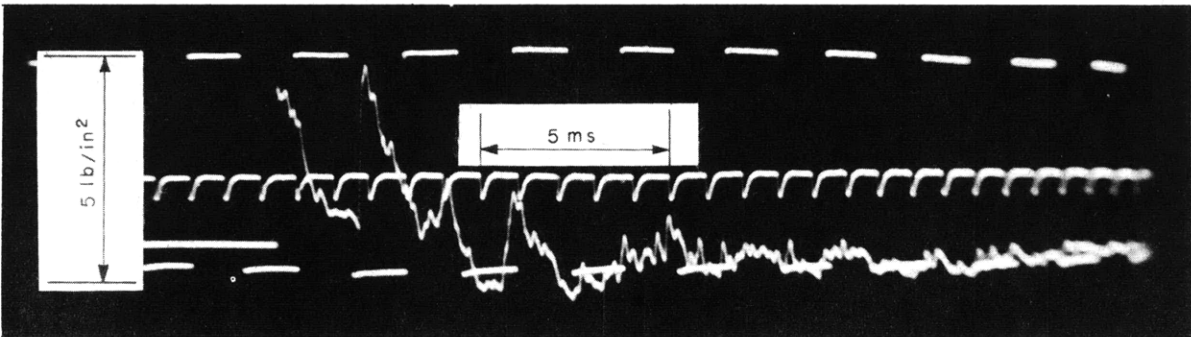

Figure 16b - Record of Tourmaline Gage B

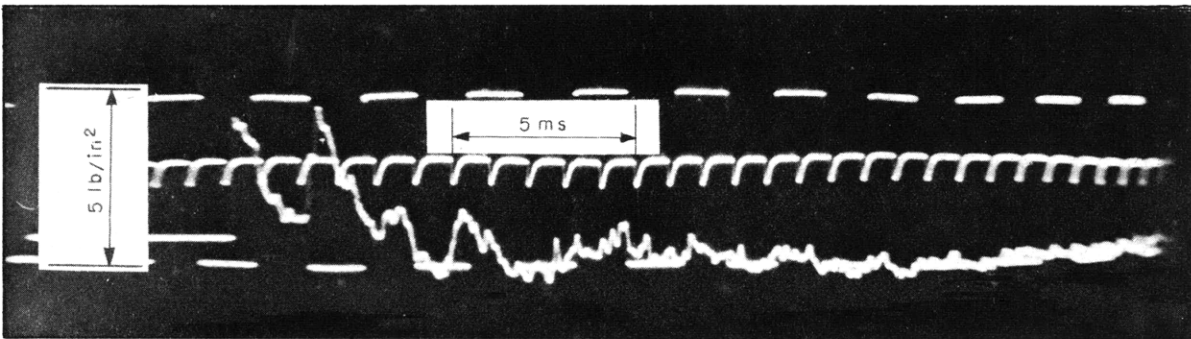

Figure 16c - Record of Tourmaline Gage C

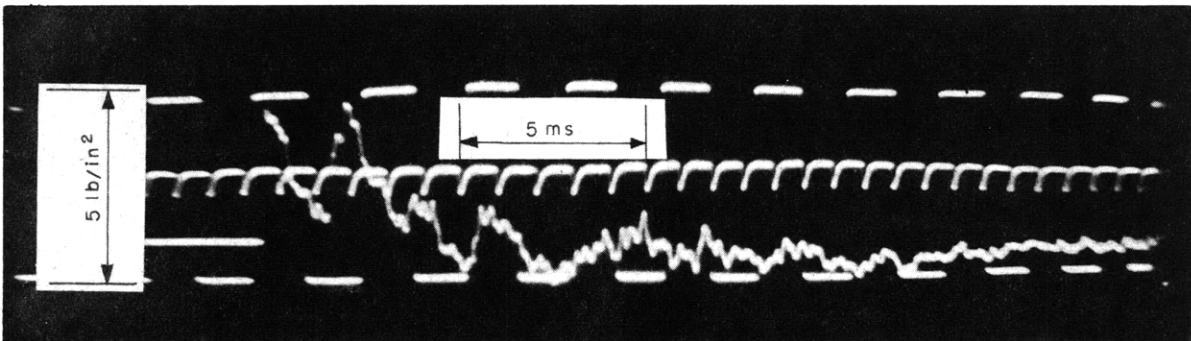

Figure 16d - Record of Tourmaline Gage D

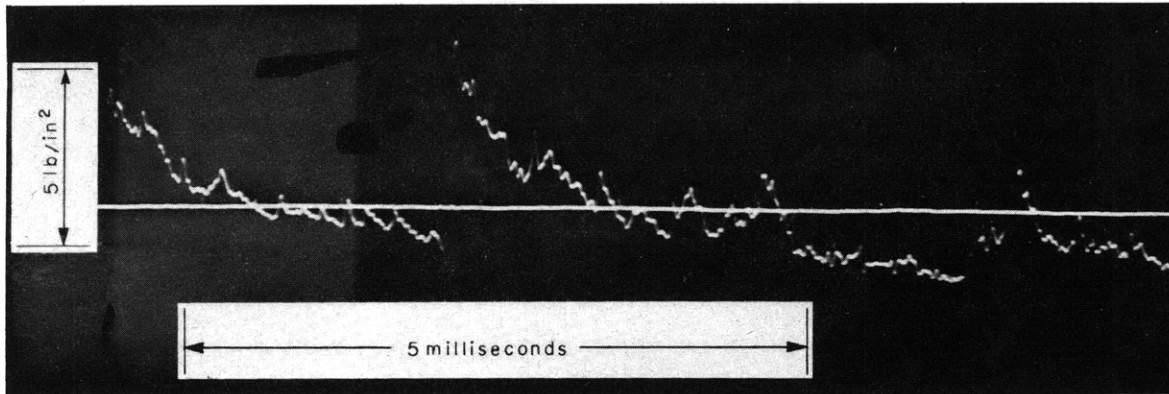

Figure 16e - Record of Diaphragm Gage 11

### Figure 16 - Test Record, Round 8

The arrows of Figure 16f indicate the pressure pulses analyzed for the comparison made in Table 2.

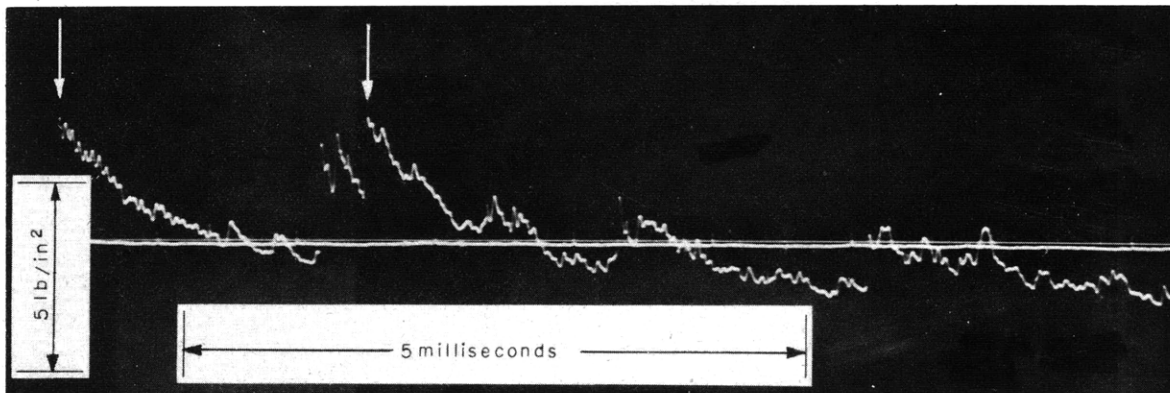

Figure 16f - Record of Diaphragm Gage 4

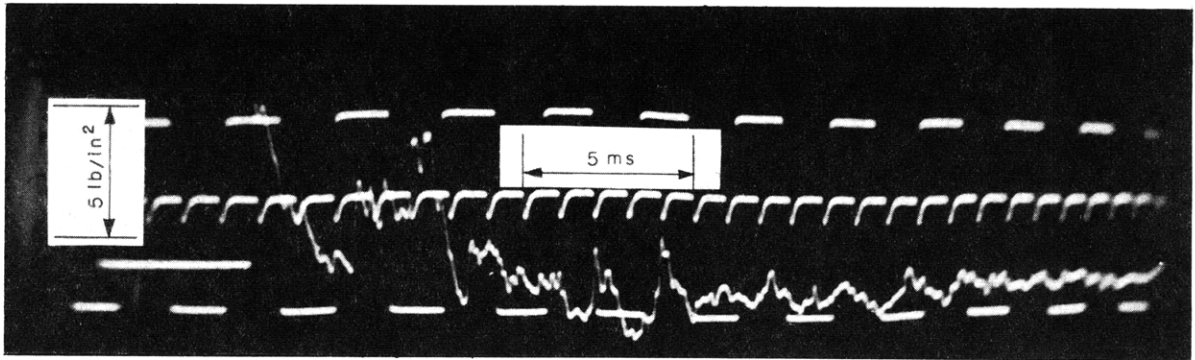

Figure 17a - Record of Tourmaline Gage A

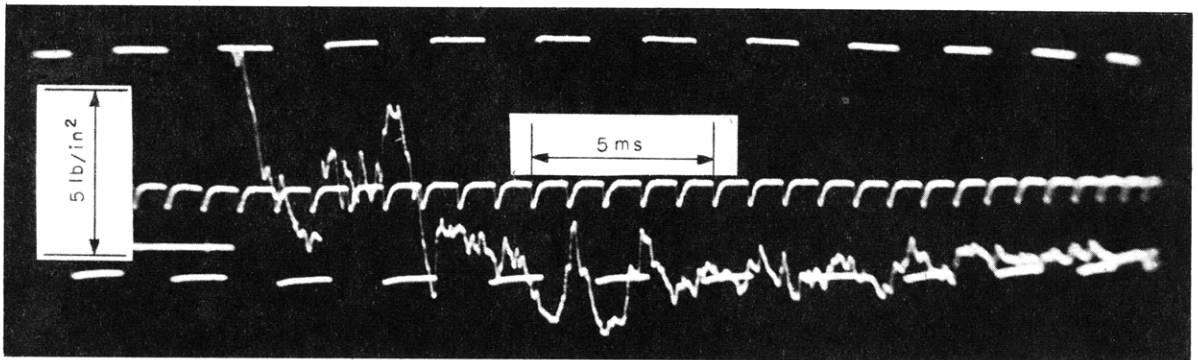

Figure 17b - Record of Tourmaline Gage B

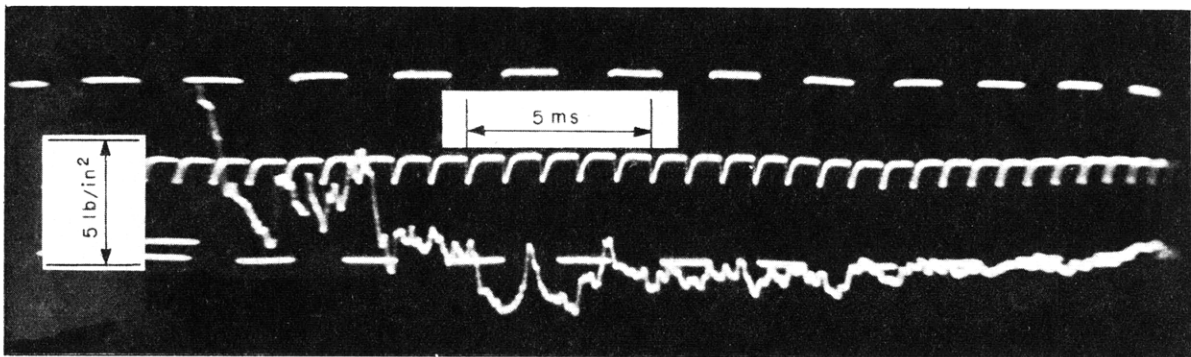

Figure 17c - Record of Tourmaline Gage C

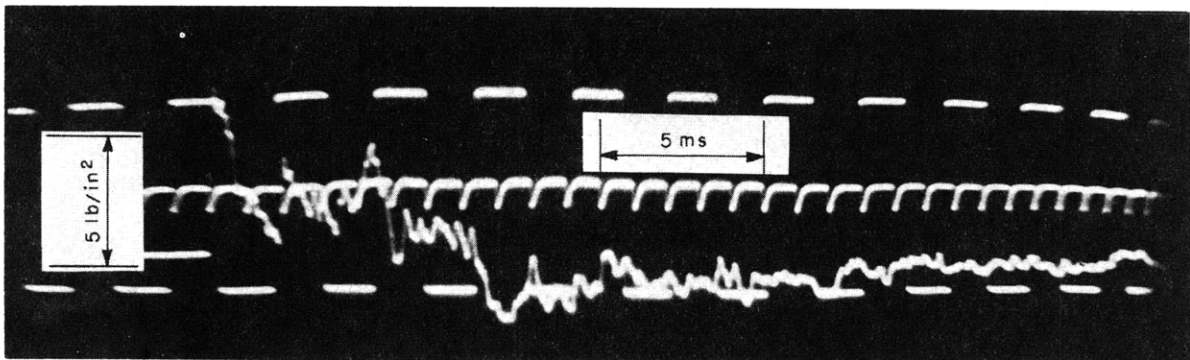

Figure 17d - Record of Tourmaline Gage D



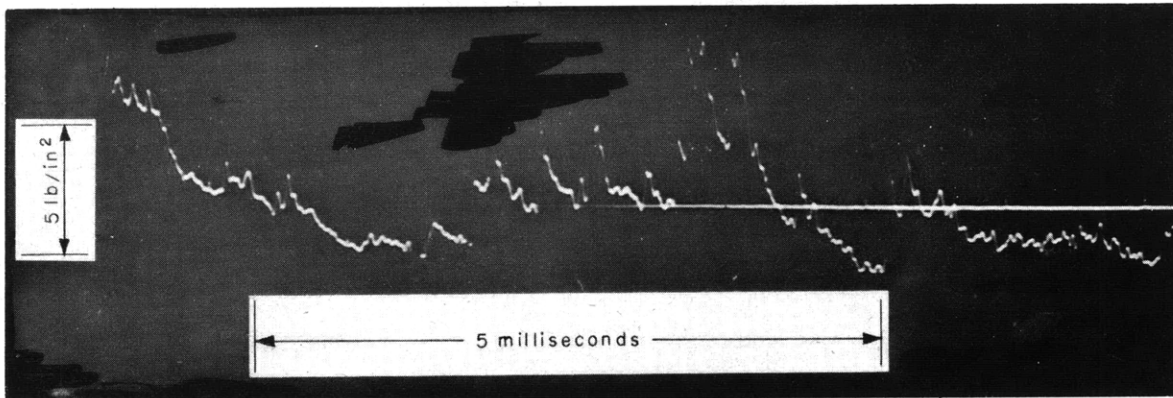

Figure 17e - Record of Diaphragm Gage 11

Figure 17 - Test Record, Round 9

The arrows of Figure 17f indicate the pressure pulses analyzed for the comparison made in Table 2.

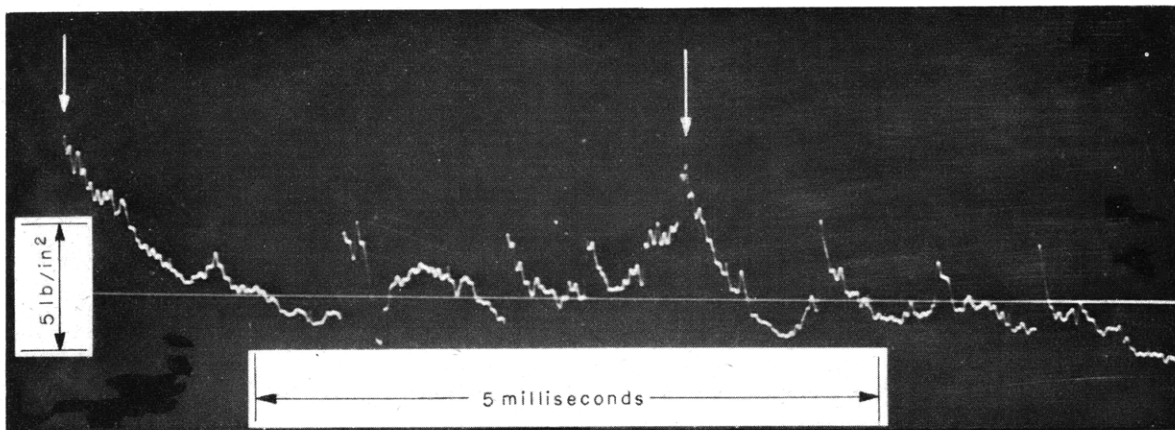

Figure 17f - Record of Diaphragm Gage 4

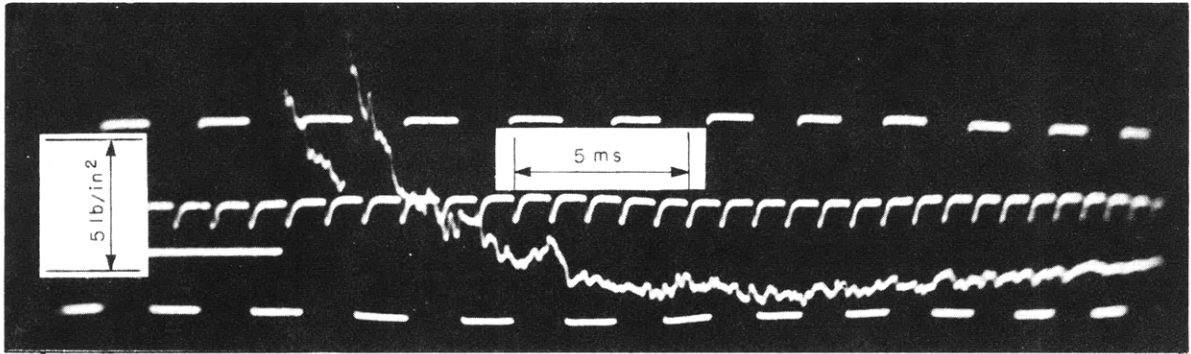

Figure 18a - Record of Tourmaline Gage A

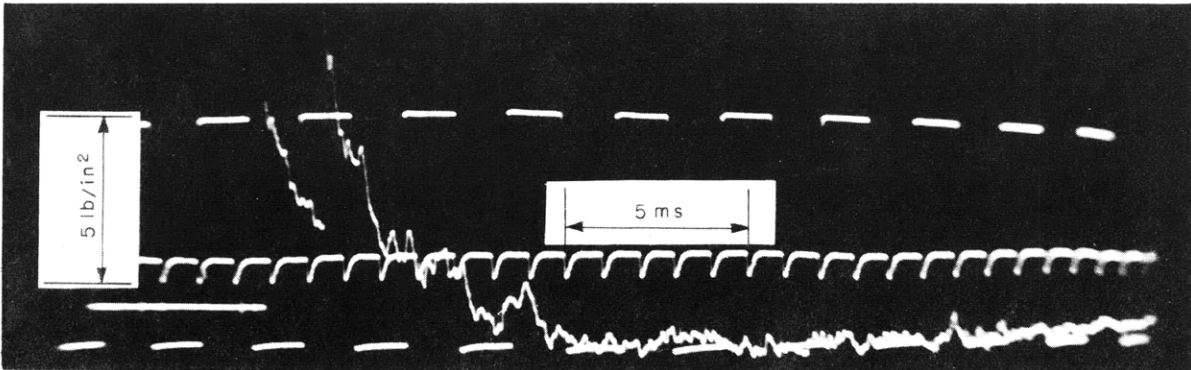

Figure 18b - Record of Tourmaline Gage B

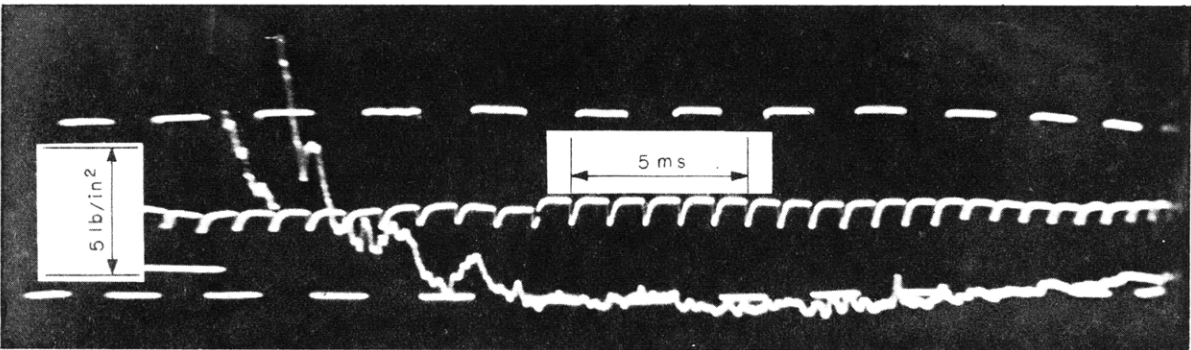

Figure 18c - Record of Tourmaline Gage C

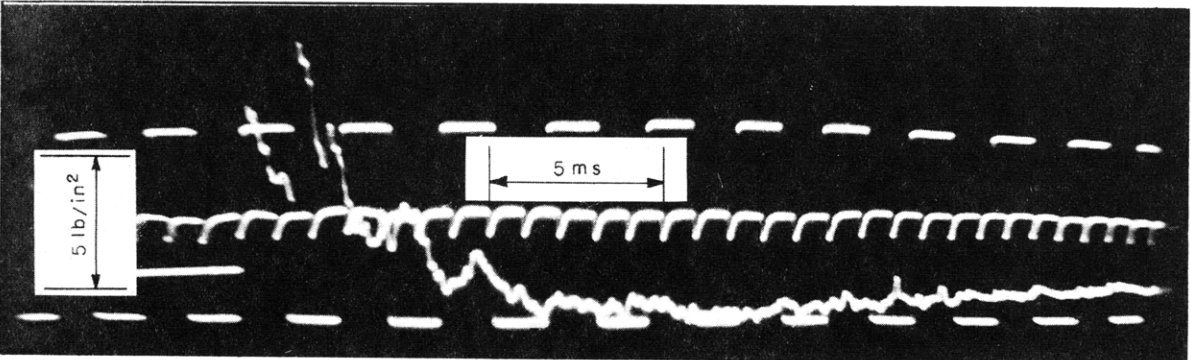

Figure 18d - Record of Tourmaline Gage D

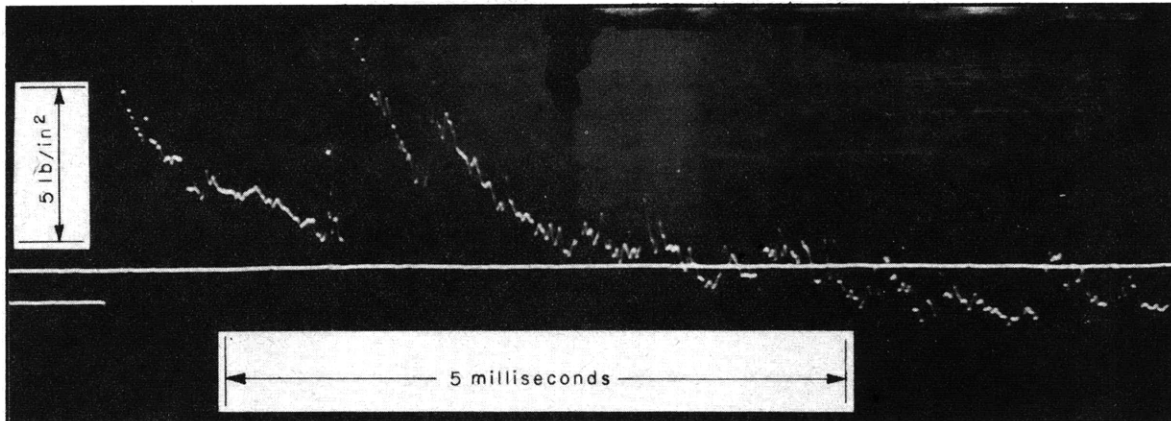

Figure 18e - Record of Diaphragm Gage 11

### Figure 18 - Test Record, Round 10

The arrows of Figure 18f indicate the pressure pulses analyzed for the comparison made in Table 2.

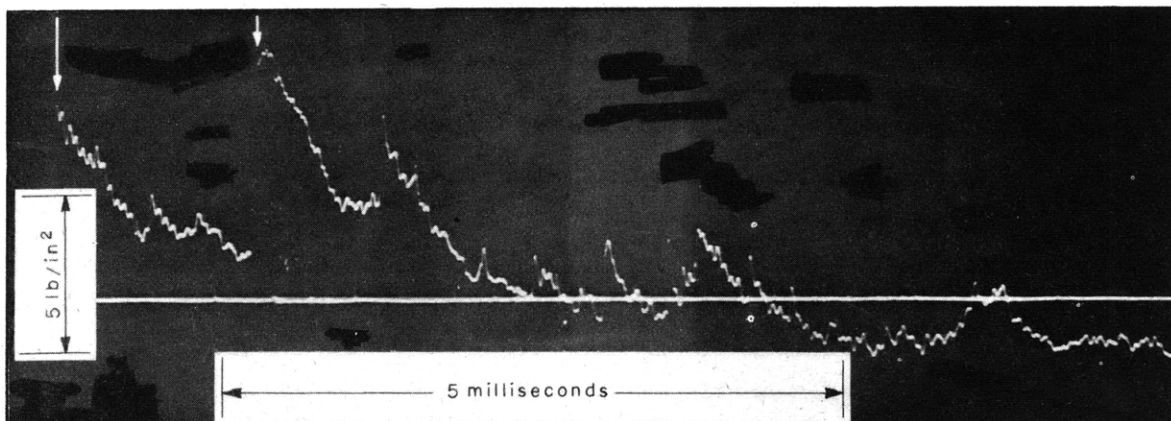

Figure 18f - Record of Diaphragm Gage 4

peak which was due to secondary after-burning effects. For similar effects in other rounds no analysis was made.

To check wave forms, the records of Tourmaline Gages A and D for Rounds 8 and 10 were replotted by Taylor Model Basin personnel on the same time and pressure scales as the corresponding diaphragm-gage records. Figure 19 shows four sets of curves for wave-form comparisons. The diaphragm-gage records were traced directly from the enlargements used for the data analysis, and the tourmaline-gage records were superimposed in the form of broken-line curves.

#### ANALYSIS OF DATA

##### TIME MEASUREMENTS

There is excellent agreement in the duration data obtained with the two types of gages. The tourmaline-gage values were estimated visually to the nearest tenth of a millisecond, which may account for some of the discrepancies. The differences that occur in the values for the total duration of positive pressure may be attributed chiefly to differences in estimating the points of zero pressure.

##### WAVE FORMS

In general the wave-form curves of Figure 19 show good agreement between the two types of gages. The corresponding impulse data would naturally compare as favorably.

Two differences in the wave-form curves deserve comment. First, the initial pressure steps for each pressure pulse, as recorded by the tourmaline gage, are consistently lower in amplitude than the corresponding pressures recorded by the diaphragm gage. However, the agreement becomes excellent for the remainder of each pulse. The reason for this consistent deviation is not known. A clue may possibly be found in the geometry of the orientation of the wave front with respect to the gage faces, which is discussed in some detail in the section headed "Peak Pressures."

An example of the second difference in wave form is indicated by the arrow in Figure 19b. This difference can be attributed to the higher resolving power of the 1/2-inch diaphragm gage as compared with the 1 5/8-inch tourmaline gage. The diaphragm gage gives a measure of the mean pressure existing in the 1/2-inch section of the blast wave acting on the diaphragm, whereas for the tourmaline gage the mean pressure is that of a 1 5/8-inch section of the wave. Therefore pressure irregularities that exist in a wave at intervals of 1/2 inch to 1 1/2 inch will be more clearly defined by the diaphragm gage. There is a possibility that this resolution feature may also partially account for the differences in the peak-pressure readings.

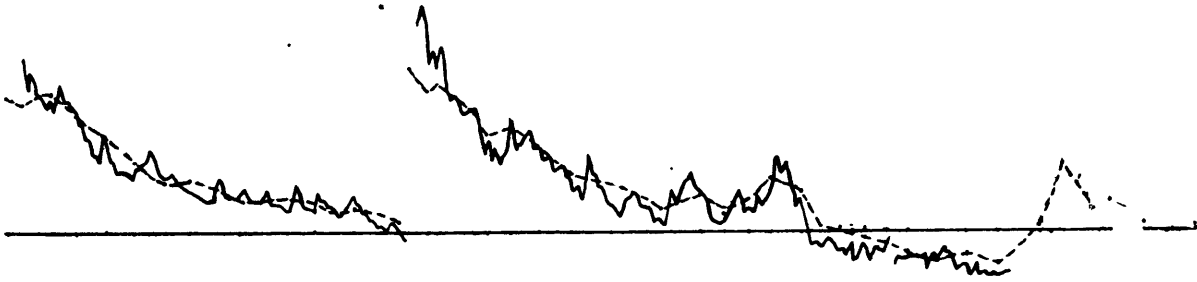

Figure 19a - Round 8, Tourmaline Gage A and Diaphragm Gage 11

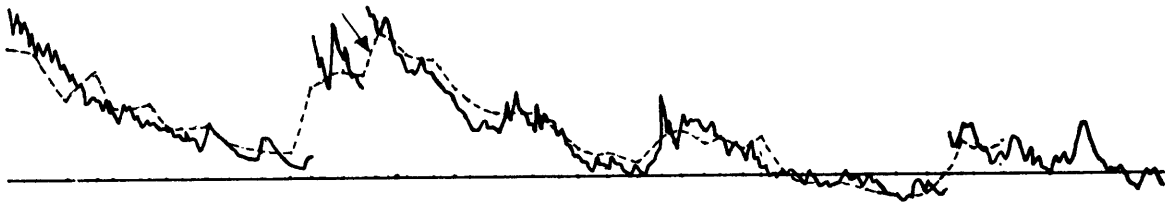

Figure 19b - Round 8, Tourmaline Gage D and Diaphragm Gage 4

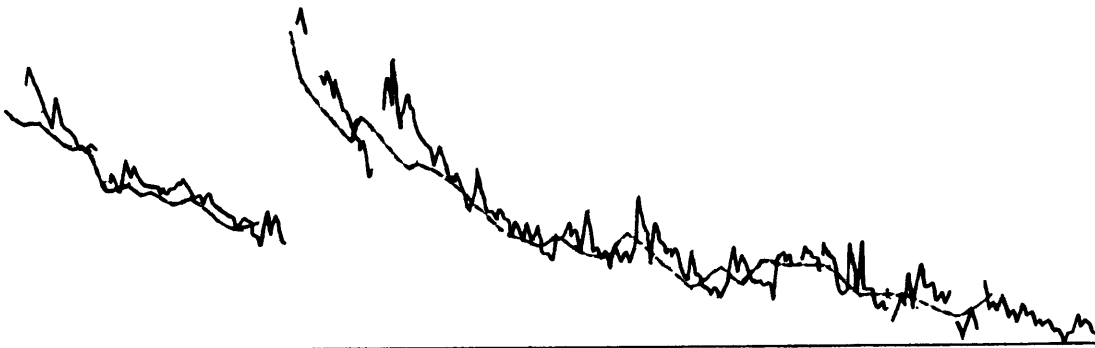

Figure 19c - Round 10, Tourmaline Gage A and Diaphragm Gage 11

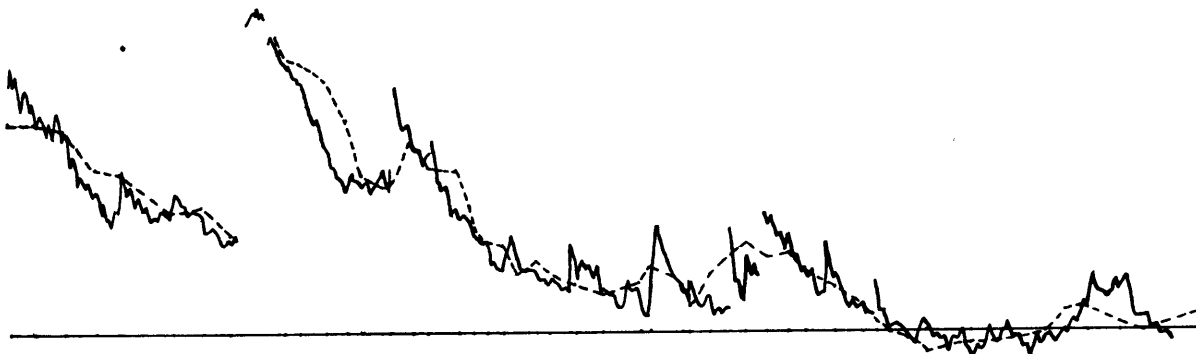

Figure 19d - Round 10, Tourmaline Gage D and Diaphragm Gage 4

Figure 19 - Superposition of the Tourmaline- and Diaphragm-Gage Records of Rounds 8 and 10 Indicating Wave-Form Agreement

The tourmaline-gage records are represented by the broken curves, whereas the diaphragm-gage records are represented by the solid curves.

## PEAK PRESSURES

A simple statistical analysis was made of the peak-pressure data. The results are given in Table 3. In this analysis, comparison was made only between the neighboring sets of gages, where the agreement should theoretically be the best. These sets consisted of the top diaphragm gage with Tourmaline Gage A and the bottom diaphragm gage with Tourmaline Gage D.

No definite trends in the data could be determined other than that the diaphragm-gage pressures were higher than the tourmaline-gage pressures in 25 out of 28 records. Table 3 indicates an average difference of about 1 1/4 pound per square inch between gage readings. On a ratio basis the tourmaline-gage pressures averaged about 20 per cent lower than the diaphragm-gage pressures. There is reason to believe that, although the gage readings differed, each gage most probably was recording correctly the true pressures acting upon it.

The orientation of the gages was such that the plane of the pressure-sensitive face was normal to the ground and directed toward the center of the gun muzzle. Earlier gun-blast measurements indicate that the wave front is not propagated radially outward from the gun muzzle, but rather in the form of an expanding spherical-shaped surface with its center moving along the line of fire. The wave front at a gage station therefore would not be normal to the gage faces; see Figure 20. In all probability some diffraction and reflection effects were introduced in the test records.

A more accurate comparison between gages might have been accomplished by the use of bare explosive charges, where the development of a spherical shock wave would have permitted placing the gage faces exactly normal to the wave front. However, the necessary facilities for such comparison were not readily available at the time the test was conducted.

Another possible cause of the gage discrepancies may be the distortion of the blast field by the presence of the gages. Investigations of this particular effect for the tourmaline gages have been made at the Woods Hole

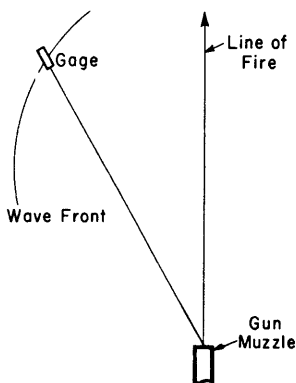

Figure 20 - Space Relation between Blast-Wave Front and Gage Face

The wave front of a blast-pressure pulse is propagated in a direction normal to itself at each point as the wave front advances. If the direction of propagation of the wave is not parallel to the plane of a gage face, then either a reflection or a diffraction effect may be introduced, depending on whether the gage face is oriented toward the wave front or away from it. The recorded signals will correspond to the distorted pressure field acting on the gage.

TABLE 3  
Summary of Peak-Pressure Data

Round	Pulse	Peak Pressure Recorded by Tourmaline Gage $P_t$ pounds per square inch	Peak Pressure Recorded by Diaphragm Gage $P_d$ pounds per square inch	$P_d - P_t$ pounds per square inch	$\frac{P_d - P_t}{P_d}$ per cent
Top Gage					
5	1	3.47	4.59	1.12	24.4
	2	5.88	6.76	0.88	13.0
6	1	3.11	4.35	1.24	28.5
	2	2.64	2.99	0.35	11.7
	3	3.67	5.84	2.17	37.2
7	1	5.29	6.12	0.83	13.6
	2	4.41	4.29	-0.12	- 2.8
8	1	3.70	4.82	1.12	23.2
	2	4.29	6.19	1.90	30.7
9	1	6.45	7.95	1.50	18.9
	2	5.46	9.29	3.83	41.2
10	1	6.58	8.19	1.61	19.6
	2	8.97	9.75	0.78	8.0
Average for positive values of $P_d - P_t$				1.44	22.5
Bottom Gage					
4	1	5.14	5.46	0.32	5.9
	2	4.16	5.06	0.90	17.8
5	1	4.09	3.98	-0.11	- 2.8
	2	7.67	6.82	-0.85	-12.5
6	1	3.30	3.70	0.40	10.8
	2	3.30	3.34	0.04	1.2
	3	4.68	6.33	1.65	26.1
7	1	4.51	5.89	1.38	23.4
	2	4.74	5.55	0.81	14.6
8	1	3.61	4.48	0.87	19.4
	2	3.84	4.56	0.72	15.8
9	1	6.71	8.24	1.53	18.6
	2	4.58	7.49	2.91	38.8
10	1	6.49	8.26	1.77	21.4
	2	9.13	10.26	1.13	11.0
Average for positive values of $P_d - P_t$				1.11	17.3

Oceanographic Institution, Woods Hole, Massachusetts (5), and the results indicate that appreciable discrepancies may be introduced by such distortion. Different distortion of the field by each of the two types of gages could possibly account for the peak-pressure deviations of Table 3.

It should be noted particularly that the two types of gages were calibrated independently and that the determined gage sensitivities were assumed to be equally reliable. There is no reason to question this assumption, but it would have been preferable to calibrate the gages simultaneously in a single pressure chamber to eliminate any possible doubts. However, a check of this sort was not made.

#### GENERAL COMMENTS

There are several anomalies in the peak-pressure data which are difficult to explain. Although not very important with respect to the purpose of the test, they deserve some mention. The irregularities are essentially of two types: First, the differences between the readings of the upper and lower sets of gages for the same blast pulse; and second, the differences between the readings of the gages of one set for successive pulses. As an example of the first type of irregularity, Tourmaline Gage A for Pulse 1 of Round 5 read 1.12 pound per square inch higher than its neighboring diaphragm gage, whereas Tourmaline Gage D read 0.11 pound per square inch lower than its neighboring diaphragm gage. For the second type of irregularity, consider the upper set of gages for Round 9; the tourmaline gage read 6.45 pounds per square inch for Pulse 1, and 5.46 pounds per square inch for Pulse 2, which is a decrease of 0.99 pound per square inch. However, the diaphragm gage indicated correspondingly an increase of 1.34 pound per square inch instead of a decrease. No explanation for these discrepancies can be offered at this time.

#### CONCLUSIONS

The test results indicate that the NDRC tourmaline gage and the TMB diaphragm gage are equally practical for blast measurements in air.

#### REFERENCES

(1) "The Taylor Model Basin Diaphragm Blast Gage," by B. Sussholz, TMB CONFIDENTIAL Report 508, December 1943.

(2) "Development of Explosion Pressure Gauges and Recording Equipment," by Dr. D. Silverman of the Stanolind Oil and Gas Company, OSRD CONFIDENTIAL Report 1739, August 1943. A report by Dr. Silverman on several more recent developments is being prepared for publication.



(3) "Comparison Tests of the Stanolind Oil and Gas Company Piezo-electric Blast-Pressure Recording Instruments and the David Taylor Model Basin Diaphragm-Type Blast-Pressure Recording Equipment," by D. Silverman and H.M. Lang of the Stanolind Oil and Gas Company, OSRD CONFIDENTIAL Report 4257, October 1944.

(4) "Report on Firing of First Eleven Rounds in 3-Inch Gun," NDRC CONFIDENTIAL Report A-229, OSRD 2019, November 1943.

(5) "Characteristics of Air-Blast Gauges; Response as a Function of Pressure Level," by A.B. Arous, C.W. Tait, G.K. Frankel, and K.M. Doane, OSRD CONFIDENTIAL Report 4875, AES-8, April 1945.



