

V393
.R46

MIT LIBRARIES

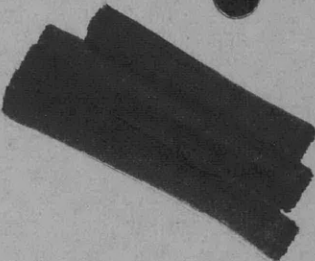

DEPARTMENT OF THE NAVY



HYDROMECHANICS



AERODYNAMICS



STRUCTURAL
MECHANICS



APPLIED
MATHEMATICS



ACOUSTICS AND
VIBRATION

CYCLIC LOADING STUDIES
OF TWO COMPOSITE CONSTRUCTION MODELS

by

John L. Proffitt



STRUCTURAL MECHANICS LABORATORY
RESEARCH AND DEVELOPMENT REPORT

August 1964

Report 1853

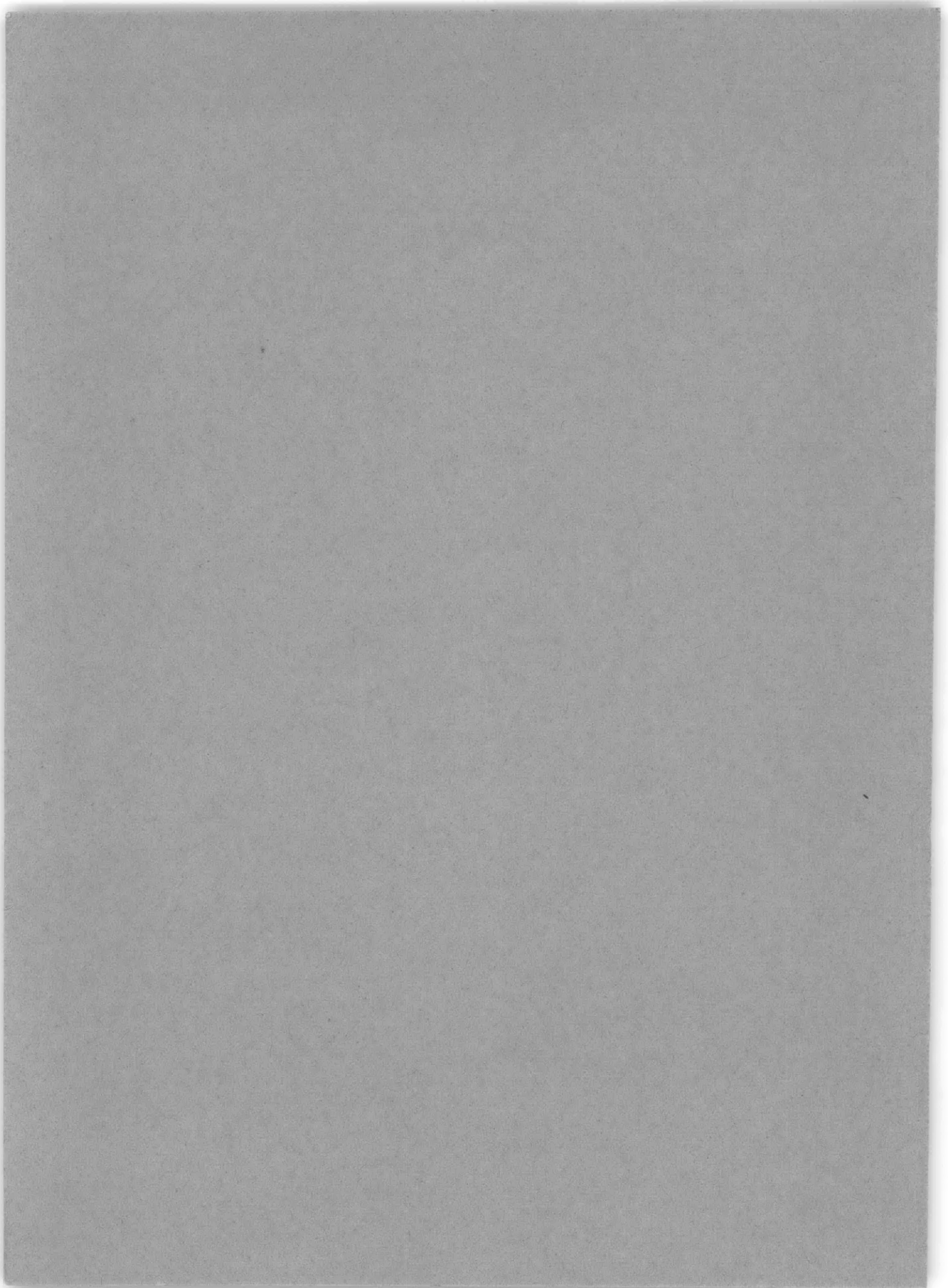

CYCLIC LOADING STUDIES
OF TWO COMPOSITE CONSTRUCTION MODELS

by

John L. Proffitt

August 1964

Report 1853
S-F013 01 03

TABLE OF CONTENTS

	Page
ABSTRACT	1
INTRODUCTION	1
DESCRIPTION OF MODELS	1
TEST PROCEDURE AND RESULTS	2
DISCUSSION AND CONCLUSIONS	3
RECOMMENDATION	4
ACKNOWLEDGMENTS	4
REFERENCES	12

LIST OF FIGURES

	Page
Figure 1 - Models DSRV-1A and DSRV-1F	5
Figure 2 - Model DSRV-1F after Fabrication	7
Figure 3 - Strain Gage Locations and Strains at 4450 PSI	8
Figure 4 - Models DSRV-1A and DSRV-1F after Cyclic Testing	11

ABSTRACT

Cyclic tests were conducted on two ring-stiffened composite cylinders consisting of high-strength aluminum rings surrounded by thin metallic jackets. Both cylinders were subjected to pressure variations corresponding to depths from 0 to 10,000 ft. The estimated static collapse depths were about 15,000 ft. Both models failed at about 12,000 cycles.

INTRODUCTION

The David Taylor Model Basin is currently engaged in a study of the feasibility of composite construction for use in deep-diving submarine pressure hulls. Composite construction is a means of utilizing high-strength nonweldable materials for deep-submergence applications. A complete description of composite construction appears in Reference 1.* As part of this program, two cylindrical models of composite construction, Models DSRV-1A and DSRV-1F, were designed for the purpose of conducting exploratory cyclic tests to determine the fatigue strength of structures with this type of construction.

Models DSRV-1A and DSRV-1F were similar to Models DSRV-1 and DSRV-1L which were tested under static loading at the Model Basin.² This report presents the results of the cyclic tests on Models DSRV-1A and DSRV-1F.

DESCRIPTION OF MODELS

Model DSRV-1A consisted of cylindrical segments of 7079-T6 aluminum with a yield strength of 76,000 psi, surrounded by a weldable aluminum jacket with a yield strength of 30,000 psi. The geometry for Model DSRV-1A was identical to that of Model DSRV-1L, which was statically tested,² except that on Model 1A the aluminum jacket replaced the HY-100 steel jacket used on Model 1L. Model 1A was originally constructed to determine the structural characteristics of a composite model with an aluminum jacket under

*References are listed on page 12.

static loading; hence, the geometry was the same as that of Model 1L. However, it was decided that Model 1A could be of greater value if it were tested cyclically. The ratio of weight of material to weight of displacement for a typical section was 0.53.

Model DSRV-1F was constructed of cylindrical segments of 7079-T6 aluminum with a yield strength of 72,000 psi and a jacket of HY-100 steel with a yield strength of 105,000 psi. Its geometry (excluding the jacket) is about 7 percent lighter than the 7079-T6 aluminum elements of Model DSRV-1A. The original model included a thinner steel jacket; however, this jacket failed after 12 pressure cycles had been applied. Subsequently, upon reassembly of the model, more care was exercised in welding a thicker jacket to provide more stability. The heavier jacket is the one depicted in the drawings and referred to hereafter. The closures and penetrations incorporated in Model 1F were designed using results of earlier static tests of closure models.³ This model weighed 58.7 percent of its displacement. Figure 1 is a sketch of Models DSRV-1A and DSRV-1F. Penetrations in the cylindrical portion of Model 1F were oriented 30 deg apart. For illustrative purposes, Figure 1b shows them to be on line. Figure 2 shows Model DSRV-1F after fabrication.

Using data from Reference 2 and correcting for differences in jacket material and disparities in yield strengths, a collapse depth of about 15,000 ft was calculated for both models.

TEST PROCEDURE AND RESULTS

Prior to cyclic testing, both models were instrumented with foil resistance gages for static loading. The static and fatigue tests were conducted at the Southwest Research Institute (SRI) at San Antonio, Texas. Strain data were recorded while the models were pressurized in the SRI 4-ft pressure tank. Two pressure runs to 3500 psi were made for each model. Figure 3 shows strain gage locations and strains extrapolated to 4450 psi. Next, the models were placed in a 30-in.-diameter tank and subjected to a pressure of 4900 psi, a 10 percent overload. During this test, the light steel jacket on Model DSRV-1F buckled. However, it was decided to continue with the cyclic test of this model and both models were placed in the SRI cyclic tank. The models were filled with oil and surrounded by

a salt water environment. The brine was then pressurized to 4450 psi and pressure applied in cycles ranging from 0 to 4450 psi to the oil. After 12 cycles, the light jacket on Model DSRV-1F failed. Subsequently, the model was removed from the tank and shipped to the Model Basin for reassembly with a heavier jacket. When this was completed, the model was static tested to 4900 psi at the Naval Research Laboratory (NRL) before being returned to Southwest Research Institute. Then both models were again placed in the SRI cyclic tank. After 500 cycles, the models were visually inspected and static tests were made on both models at each subsequent 500-cycle interval. The fatigue test continued until both models failed at a point between 11,500 and 12,000 cycles. The failure of these models was due to circumferential crack propagation at the weld line joining the jacket to the end ring. A longitudinal crack in the jacket of Model DSRV-1A is apparent also. Examination of the 7079-T6 aluminum components of both models failed to reveal any damage to these parts. See Figure 4 for photographs of Models DSRV-1A and DSRV-1F after cyclic testing.

DISCUSSION AND CONCLUSIONS

Several significant points were brought to light by these rather exploratory tests. The results of the cyclic tests were fairly encouraging since both models withstood almost 12,000 pressure cycles to 4450 psi. Failure to discover any structural damage to the 7079-T6 rings and frames after cycling is evidence that it is possible to design a composite hull, weighing 53 to 58 percent of its displacement, that will withstand 10,000 excursions to a depth of 10,000 ft.

There is a definite need, however, for further cyclic tests on models of composite construction. More information is needed on the effect of scale on fatigue life; larger models are required to establish a correlation between size and structural characteristics. Certainly the small scale of these two models contributed to fabrication and tolerance problems and led to residual stresses which would be relieved or eliminated on larger models. The unsatisfactory results obtained with the thin jacket on Model DSRV-1F can be attributed to fabrication difficulties arising from the thinness and relative instability of this jacket. Conversely, it is true that the fatigue life of plating decreases as the plate thickness

increases. Tests on larger scale models can be utilized to study this effect also.

The problem of adequately penetrating and closing cylindrical pressure hulls of composite construction is another large problem area. Here again, the results of these tests are encouraging. Since the two hull penetrations and both end closures showed no ill effects after 12,000 cycles, there is reason to believe that properly designed penetrations and end closures should not affect the fatigue life of composite structures.

If further cyclic tests substantiate the fairly promising results of these preliminary tests, composite construction will definitely show promise as a method of fabricating deep submergence pressure hulls.

RECOMMENDATION

The fatigue strength of large-scale composite cylinders should be investigated to develop a correspondence between scale and fatigue characteristics.

ACKNOWLEDGMENTS

The author wishes to express his appreciation for the contributions of Mr. Martin A. Krenzke and Mr. Peter M. Palermo who supplied the test data, Mr. Nicholas G. Laios of the Naval Research Laboratory who conducted the second static test of Model DSRV-1F, and Mr. Jack R. Pohlman of the Southwest Research Institute who conducted the cyclic tests.

Figure 1 - Models DSRV-1A and DSRV-1F

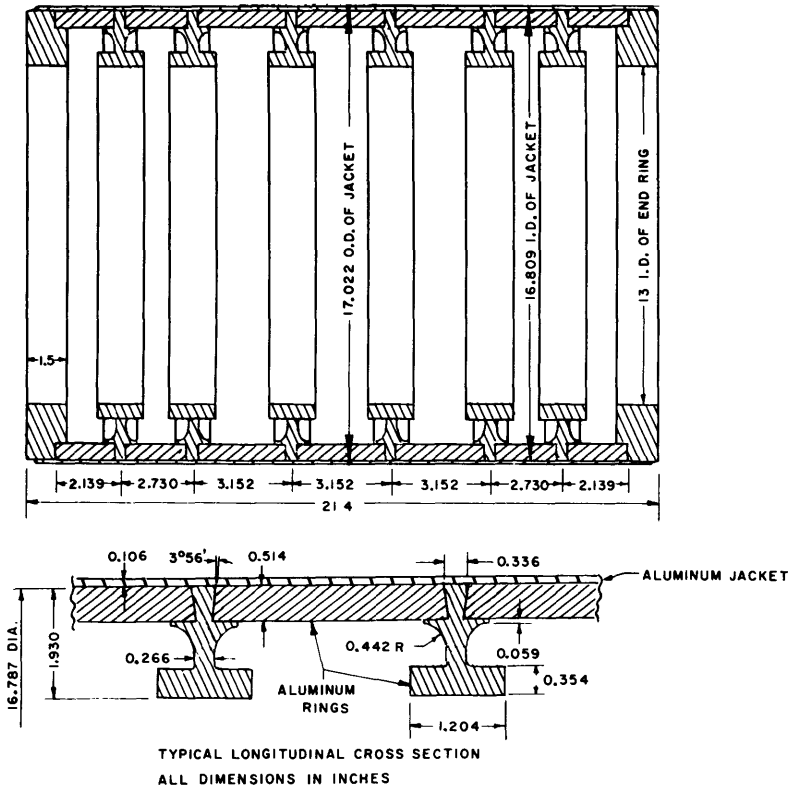

Figure 1a - Model DSRV-1A

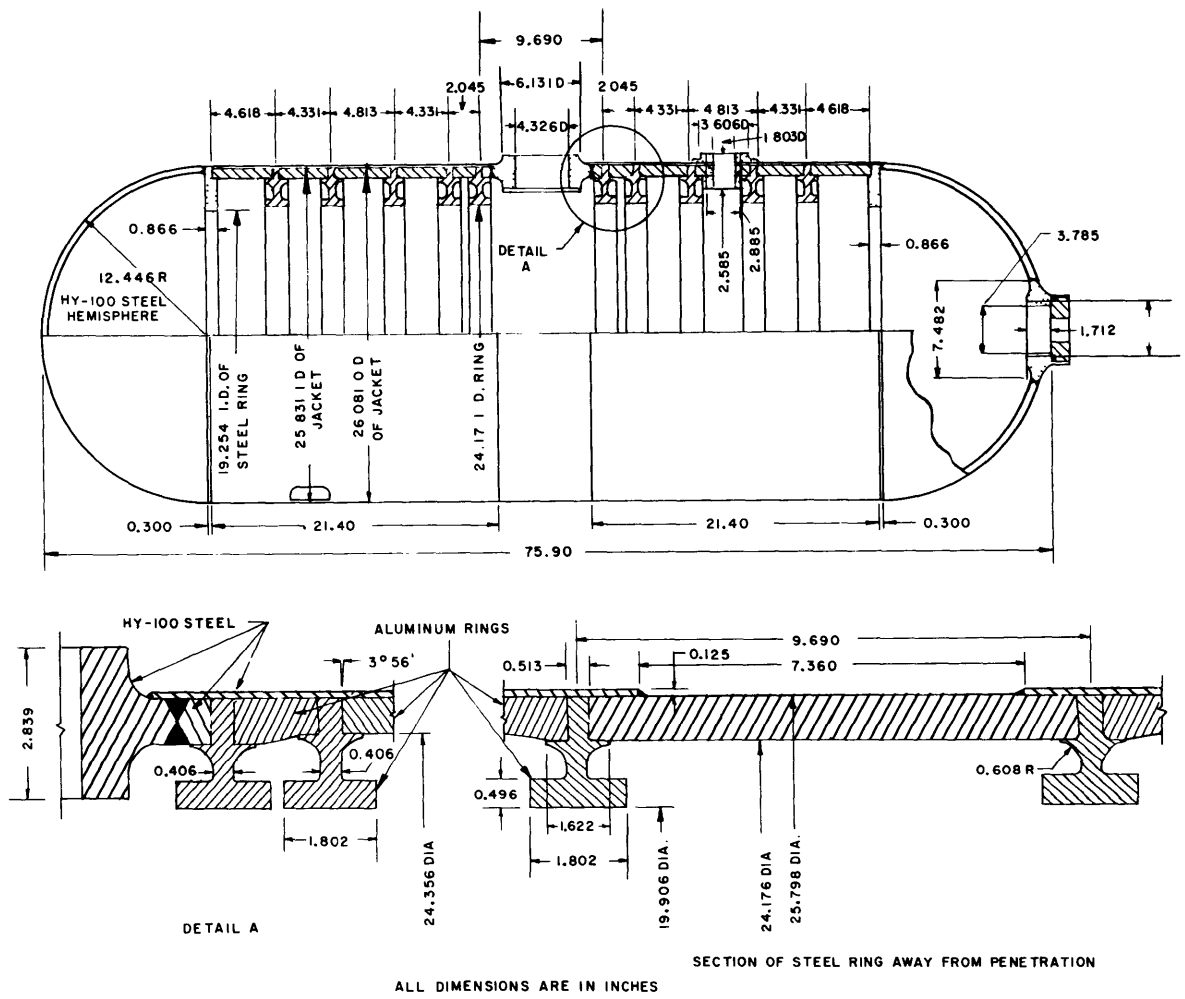

Figure 1b - Model DSRV-1F

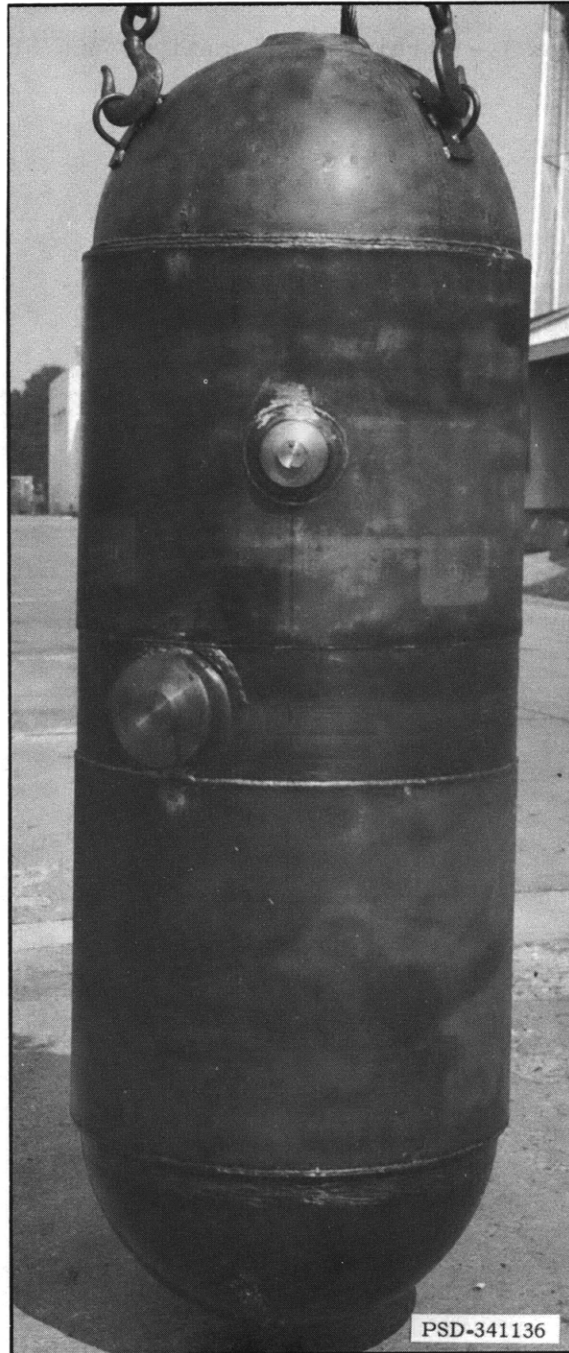

Figure 2 - Model DSRV-1F after Fabrication

Figure 3 - Strain Gage Locations and Strains at 4450 PSI

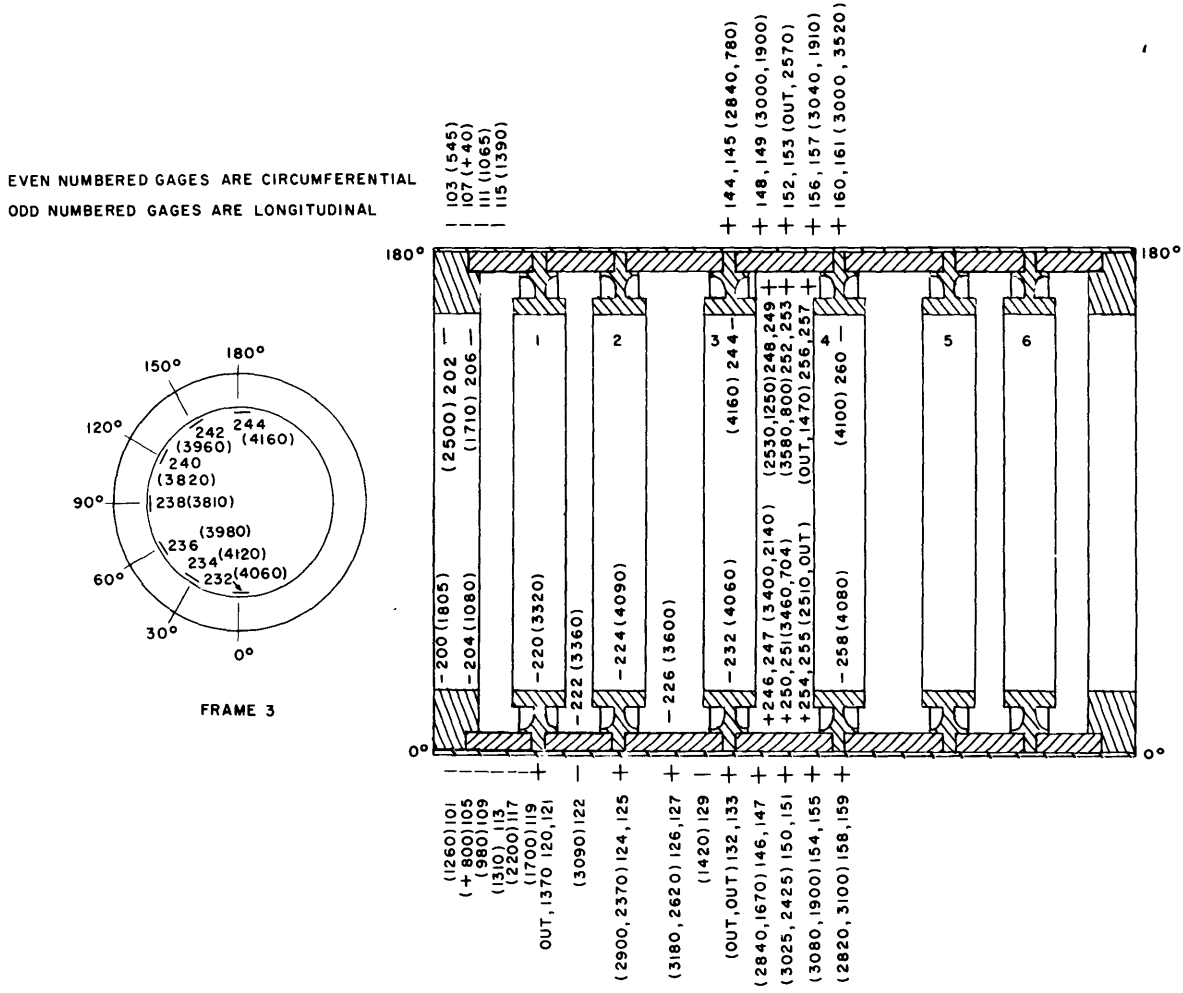

Figure 3a - Model DSRV-1A

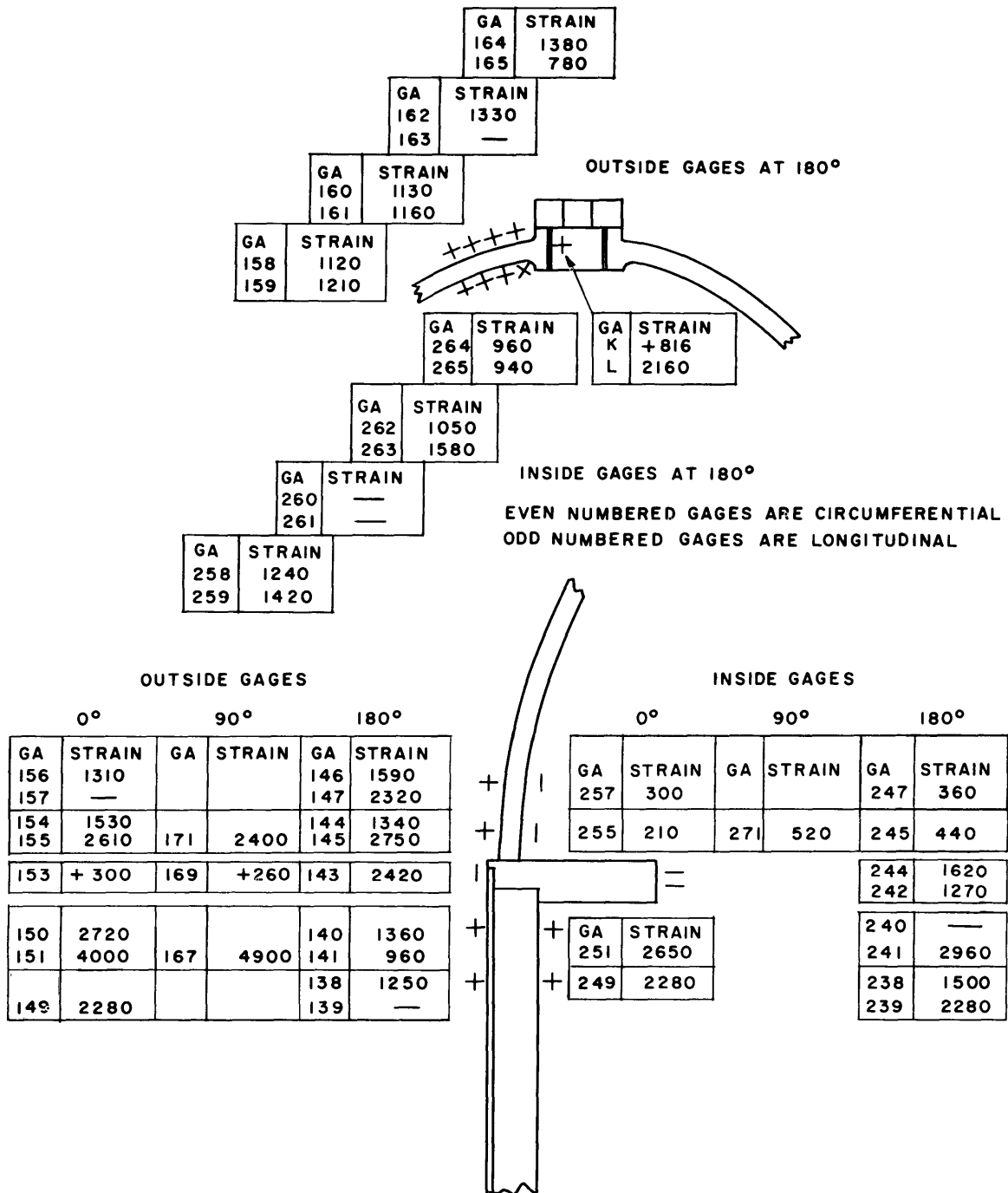
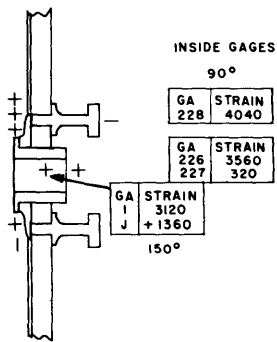

Figure 3b - Model DSRV-1F

OUTSIDE GAGES

90°		180°	
GA	STRAIN	GA	STRAIN
136	4160	134	2840
137	4300	135	3800
GA	STRAIN	GA	STRAIN
131	2320	128	3070
		129	3330
		132	1720
		133	—
126	3050		
127	2560		
124	2840		
125	2460		
123	2680		



EVEN NUMBERED GAGES ARE CIRCUMFERENTIAL
ODD NUMBERED GAGES ARE LONGITUDINAL

OUTSIDE GAGES

0°		90°		180°		225°		270°	
GA	STRAIN	GA	STRAIN	GA	STRAIN	GA	STRAIN	GA	STRAIN
116	2060	118	1860	120	2210	119	—	121	—
117	4000	119	—	121	—	118	1860	120	2210
114	1930								
115	4200								
GA	STRAIN	GA	STRAIN						
110	2020	108	1960						
111	290	109	660						
				106	1730				
				107	830				
		105	875						
		102	—						
		103	280						
		100	2370						
		101	1300						

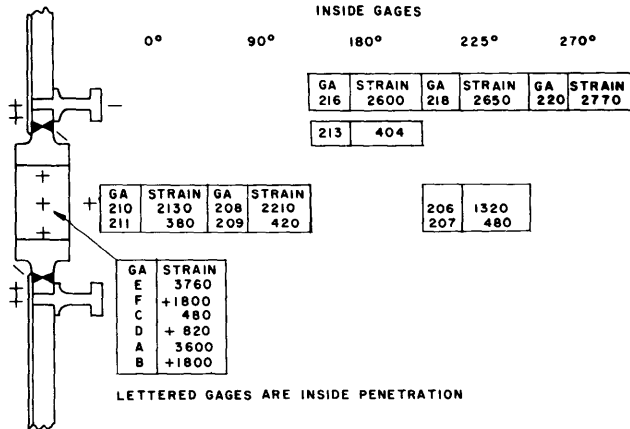

LETTERED GAGES ARE INSIDE PENETRATION

Figure 3c - Model DSRV-1F

Figure 4 - Models DSRV-1A and DSRV-1F after Cyclic Testing

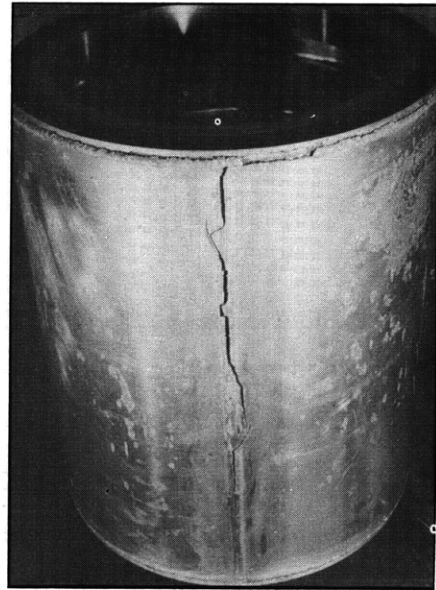
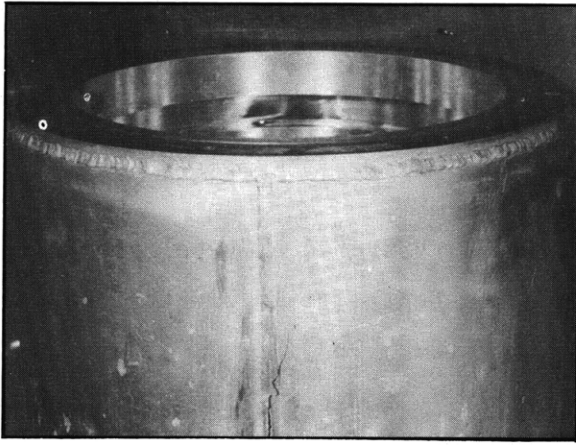

Figure 4a - Model DSRV-1A

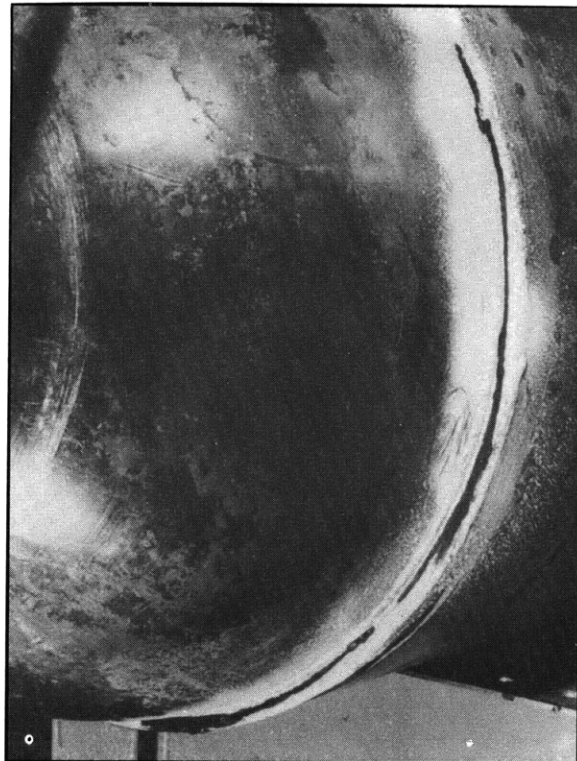

Figure 4b - Model DSRV-1F

REFERENCES

1. Krenzke, M. A. and Kiernan, T. J., "Structural Development of a Titanium Oceanographic Vehicle for Operating Depths of 15,000 to 20,000 Feet," David Taylor Model Basin Report 1677 (Sep 1963).

2. Krenzke, M. A. and Kiernan, T. J., "Tests of Ring-Stiffened and Sandwich Composite Cylinders Under External Hydrostatic Pressure," David Taylor Model Basin Report 1725 (Sep 1963).

3. Kiernan, T. J. and Krenzke, M. A., "An Experimental Investigation of Closures and Penetrations for Pressure Vessels of Composite Construction," David Taylor Model Basin Report 1732 (Feb 1964).

INITIAL DISTRIBUTION

Copies		Copies	
16	CHBUSHIPS	1	SUPSHIP, Newport News
	2 Sci & Res Sec (Code 442)	1	NNSB & DD Co
	1 Lab Mgt (Code 320)	1	SUPSHIP, Pascagoula
	3 Tech Info Br (Code 210L)	1	Ingalls Shipbldg Corp
	1 Struc Mech, Hull Mat & Fab (Code 341A)	1	SUPSHIP, Camden
	1 Prelim Des Br (Code 420)	1	New York Shipbldg Corp
	2 Prelim Des Sec (Code 421)	1	SUPSHIP, Quincy
	1 Ship Protec (Code 423)	1	DIR, DEF R & E, Attn: Tech Lib
	1 Hull Des Br (Code 440)	1	CO, USNROTC & NAVADMINU, MIT
	1 Struc Sec (Code 443)	1	
	1 Sub Br (Code 525)	1	
	1 Hull Arrgt, Struc, & Preserv (Code 633)	1	
	1 Pres Ves Sec (Code 651F)	1	
2	CHONR	1	O in C, PGSCOL, Webb
	1 Struc Mech Br (Code 439)	1	DIR, APL, Univ of Wash, Seattle
	1 Undersea Programs (Code 466)	1	NAS, Attn: Comm on Undersea Warfare
4	CNO	1	WHOI
	1 Tech Anal & Adv Gr (Op 07T)	1	1 Mr. J. Mavor
	1 Plans, Programs & Req Br (Op 311)	1	Dr. E. Wenk, Jr., The White House
	1 Sub Program Br (Op 713)	1	Dr. R. DeHart, SWRI
	1 Tech Support Br (Op 725)	1	Mr. L. P. Zick, Chic Bridge & Iron Co, Chicago
2	CHBUWEPS, SP-001	1	Prof. E. O. Waters, Yale Univ.
20	CDR, DDC	2	Mr. C. F. Larson, Sec, Welding Research Council
1	CO & DIR, USNMEL	1	Mr. J. L. Mershon, AEC
1	CDR, USNOL		
1	DIR, USNRL (Code 2027)		
1	CO & DIR, USNUSL		
1	CO & DIR, USNEL		
1	CDR, USNOTS, China Lake		
1	CDR, USNOTS, Pasadena		
1	CO, USNUOS		
2	NAVSHIPYD PTSMH		
2	NAVSHIPYD MARE		
1	NAVSHIPYD CHASN		
1	SUPSHIP, Groton		
1	EB Div, Gen Dyn Corp		

LIBRARIES DUPL
MIT LIBRARIES DUPL



3 9080 02993 0861

