

MIT LIBRARIES

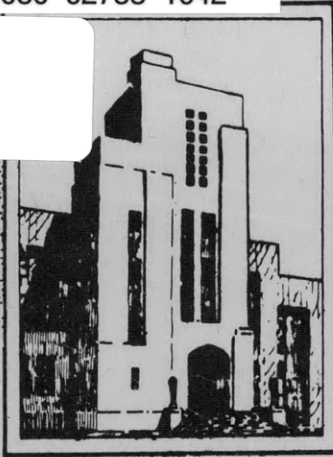

3 9080 02753 1042

V393
.R468



DEPARTMENT OF THE NAVY
DAVID TAYLOR MODEL BASIN

HYDROMECHANICS

○

AERODYNAMICS

○

STRUCTURAL
MECHANICS

○

APPLIED
MATHEMATICS

THE STRENGTH OF CYLINDRICAL SHELLS, STIFFENED BY
FRAMES AND BULKHEADS, UNDER UNIFORM
EXTERNAL PRESSURE ON ALL SIDES

(Über das Festigkeitsproblem querversteifter Hohlzylinder
unter allseitig gleichmässigem Aussendruck)

by

K. von Sanden, Kiel and K. Günther, Danzig

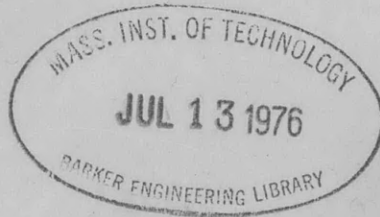

Translated by Dr. E.N. Labouvie

Annotated by Dr. E. Wenk, Jr. and Dr. W.A. Nash

March 1952

Translation 38



INITIAL DISTRIBUTION

Copies

- 9 Chief, Bureau of Ships, Project Records (Code 324), for distribution:
 - 5 Project Records
 - 1 Technical Assistant to Chief of Bureau (Code 106)
 - 1 Preliminary Design (Code 420)
 - 1 Hull Design (Code 440)
 - 1 Hull Design, Scientific (Code 442)
- 2 Chief, Office of Naval Research, Mechanics and Materials Branch
- 2 Chief of Naval Operations, Op-322-F2
- 2 Chief, Bureau of Ordnance
- 2 Chief, Bureau of Aeronautics
- 2 Commander, Naval Ordnance Laboratory
- 2 Director, Naval Research Laboratory
- 2 Commander, Norfolk Naval Shipyard, Underwater Explosions Research Division (Code 290), Portsmouth, Va.
- 2 Director, National Bureau of Standards
- 5 Director of Aeronautical Research, National Advisory Committee for Aeronautics, 1724 F St., N.W., Washington 25, D.C.
- 1 Library, Polytechnic Institute of Brooklyn, Brooklyn, N.Y.
- 1 Library, University of Michigan, Ann Arbor, Mich.
- 1 Library, University of Illinois, Urbana, Ill.
- 1 Library, Illinois Institute of Technology, Chicago, Ill.
- 1 Library, Massachusetts Institute of Technology, Cambridge, Mass.
- 2 Library of Congress, Washington, D.C.
- 9 British Joint Services Mission (Navy Staff), P.O. Box 165, Benjamin Franklin Station, Washington, D.C.

THE STRENGTH OF CYLINDRICAL SHELLS, STIFFENED BY FRAMES AND BULKHEADS,
UNDER UNIFORM EXTERNAL PRESSURE ON ALL SIDES

(ÜBER DAS FESTIGKEITSPROBLEM QUERVERSTEIFTER HOHLZYLINDER
UNTER ALLSEITIG GLEICHMÄSSIGEM AUSSENDRUCK)

by

K. von Sanden, Kiel

and

K. Günther, Danzig

Werft and Reederei, Vol. 1 (1920), Nos. 8, 9, and 10
and Vol. 2 (1921), No. 17

Translated by Dr. E.N. Labouvie

Annotated by Dr. E. Wenk, Jr. and Dr. W.A. Nash

March 1952

Translation 38

ANNOTATORS' INTRODUCTION

The work of von Sanden and Günther translated here is well known because of the expressions commonly referred to as Formulas (92) and (92a). They give the longitudinal stress at the frame and the circumferential stress midway between frames, respectively, occurring in a thin circular cylindrical shell reinforced by circumferential frames and loaded by hydrostatic pressure.

Formula (92a) as originally published by von Sanden and Günther is incorrect. In their equation the coefficients of the transcendental terms in the numerator of the function H were erroneously interchanged and the sign connecting these terms should have been positive. These errors were noted by W. Hovgaard ("Memorandum No. 88 to the Bureau of Construction and Repair," 20 December 1921) and again by C. Trilling ("The Influence of Stiffening Rings on the Strength of Thin Cylindrical Shells under External Pressure," TMB Report 396, February 1935).

However, the analysis of von Sanden and Günther neglected the effect of the axial component of hydrostatic pressure upon the stress distribution in the shell. It also failed to take into account the boundary conditions discussed by F. Viterbo ("Sul problema della robustezza di cilindri cavi rinforzati trasversalmente sottoposti da ogni parte a pressione esterna," L'Ingegnere, Vol. IV, July 1930, pp. 446-456; August 1930, pp. 531-540). Both of these inconsistencies were properly accounted for by V.L. Salerno and J. Pulos in a forthcoming report to be released by the Polytechnic Institute of Brooklyn.

The original work of von Sanden and Günther has been annotated so that this translation makes mention of some developments that have taken place since the publication of the original document. Also, the equations have been renumbered according to a somewhat more systematic procedure. The original numbering system appears at the left side of the equations and the newly assigned numbers at the right side.

Dr. E. Wenk, Jr.
Dr. W.A. Nash

The translator wishes to acknowledge his indebtedness to Professor W. Hovgaard for much valuable assistance derived from a comparison of this translation with the latter's Memorandum No. 88 to the Bureau of Construction and Repair, especially with respect to the technical terminology and phraseology used in this series of articles.

Memorandum No. 88 (C & R No. 9563-A27) represents an abstract of these articles containing also a number of corrections and annotations contributed by Prof. Hovgaard himself or by Dr. Dwight Windenburg of the David W. Taylor Model Basin who collaborated with Prof. Hovgaard in editing the memorandum.

Dr. E.N. Labouvie

TABLE OF CONTENTS

	Page
INTRODUCTION	1
PART I - THEORY	
1. GENERAL STATEMENTS - THE STRAIGHT ROD	2
2. THE CIRCULAR RING OR FRAME	11
a. Uniform Internal Pressure p_i	11
b. Uniform External Pressure p_a	13
3. UNSTIFFENED CYLINDRICAL TUBE OF INFINITE LENGTH	16
a. Uniform Internal Pressure p_i	16
b. External Pressure p_a	17
4. THE FREE CYLINDRICAL TUBE STIFFENED BY TRANSVERSE FRAMES	19
a. Uniform Internal Pressure p_i	19
b. Uniform External Pressure p_a	45
5. CYLINDRICAL TUBE STIFFENED BY TRANSVERSE FRAMES AND LOADED BY END-PRESSURE	52
a. Uniform Internal Pressure p_i	52
b. Uniform External Pressure p_a	57
PART II - EXPERIMENTS AND PRACTICAL APPLICATIONS OF THE THEORY DEVELOPED IN PART I	
6. EXPERIMENTS WITH MODELS OF STRENGTH HULLS OF SUBMARINES	63
7. PRACTICAL EXAMPLES	70
BIBLIOGRAPHY	80

NOTATION

Symbol	German word	English equivalent
A	Auflagerreaktion	shearing force at the support
D	gesamte Druckbelastung	total load in compression
d	der Druck	pressure, compression
E	Elastizitätsmodul	modulus of elasticity
e	Exzentrizität	eccentricity
F	die Fläche	surface, face, area
F_a	Aussenfaser	outer extreme fiber (A_o)
F_i	innere Randfaser	inner extreme fiber (A_i)
f	der Fluss	flow
J	Trägheitsmoment	moment of inertia
M	Biegemoment	bending moment
M_A	Auflagermoment	moment at the support
m	Poisson - Zahl	Poisson's number (reciprocal of Poisson's ratio)
p	proportional	proportional
p_a	Aussendruck	external pressure
p_i	Innendruck	internal pressure
\bar{p}	radiale Gesamtbelastung	total radial load per cm of circumference of the frame
or s	Höhe	radial depth of a ring
s	Wandstärke	thickness of shell plating
W	Widerstandsmoment	section modulus
Z	gesamte Zugbelastung	total load in tension
z	der zug	pull, tension
ϵ	Beanspruchung	strain
ϵ_d		strain in contraction
ϵ_z		strain in extension
ρ	Scherkraft	shearing force
Subscripts		
fd		yield point } with external pressure and compressive stress
pd		
fz		yield point } with internal pressure and tensile stress
pz		

INTRODUCTION

The question of the superiority of hulls of elliptical cross section, with the major axis horizontal—versus circular sections (as normally employed)—has always been a highly controversial subject ever since the construction of submarines was begun. The better utilization of space seemed to be an argument in favor of the elliptical section whereas the better strength properties, which incidentally are easier to calculate, are pointed to as favoring the circular section. The latter argument, however, was declared incorrect in many details by the advocates of the elliptic section.

The Germaniawerft could not disregard this problem since the tendency toward adoption of the elliptic section was widespread within the German Navy. At the suggestion of the Germaniawerft model experiments were undertaken since, in the opinion of all concerned, a decision for or against the **introduction** of the elliptic section appeared, on a purely theoretical basis, to be impossible in view of the numerous strength problems which were still unsolved. Extensive systematic experiments were first undertaken by the Germaniawerft and preparations were made to test 1/5 scale models under uniform hydrostatic pressures up to 25 kg/cm² corresponding to depths of immersion up to 250 m (822 feet). Provision was made for exact observations of the deformation of the interior of the strength hull and measurements of the elastic changes could be made at any moment during the pressure test. As a rule, the pressure was increased until the destruction of the model was accomplished. The model experiments later undertaken at the (formerly imperial) shipyard at Danzig, as well as observations of the damage sustained in boats which had accidentally descended to too great depths, constituted a very valuable supplementary addition to the tests.

Parallel with these experiments, the Germaniawerft and the Naval Authorities (Submarine Inspection at Kiel), ordering the undertaking of this project, carried on extensive theoretical investigations; a part of the results obtained was published in the fourth edition of Johow's "Hilfsbuch für den Schiffbau," Section 9.^{1*} The first part of the present article deals with a detailed presentation of the fundamentals of the entire theory and a derivation of the principal formulas. In connection with this an effort was made to discuss the entire range of problems, which is rather complicated in some respects, in relation to the simplest elastostatic concepts.**

¹Bibliography is on page 80.

*See also Dr.-Ing. H. Techel, "Der Bau von Unterseebooten auf der Germaniawerft," Z.V.D.I., 1919, p. 1302.

**Annotators' Note: In the interest of brevity, the reader may, if desired, proceed directly to Section 4.

Hence, we shall discuss successively:

1. The straight rod
 - a. in tension,
 - b. in compression;
2. The thin circular ring;
3. The unstiffened circular cylindrical tube of infinite length (no frames);
4. The free circular cylindrical tube (capable of longitudinal expansion and contraction) stiffened by transverse frames;
5. The circular cylindrical tube closed at the ends by bulkheads and stiffened by transverse frames.

Each of the cases 2, 3, 4 and 5 are dealt with: (a) under internal pressure, and (b) under external pressure.

In Section 4, the beam fixed at both ends and subjected to a uniformly distributed load has been discussed as a special case of strength-hull plating which is unsupported from frame to frame. The technical progress made as a result of the application of the general theory of elasticity will be discussed at the end of Part I.

The second part deals with the application of the theoretical results thus obtained to the best choice of scantlings and dimensions of the strength hull of submarines and other similar bodies whose occurrence is, of course, not limited to the design of submarines only.

PART I - THEORY

1. GENERAL STATEMENTS. - THE STRAIGHT ROD.

Simple tension or compression of a straight rod are analogous respectively to a resultant internal or external excess pressure, uniform on all sides, on circular rings and tubes (see Figures 1, 2 and 3).

In the case of pure tensile stress (Figure 3) only the tensile stress which exists in the most unfavorable (smallest) section, i.e., the maximum tensile stress $\sigma_z = Z/F$ needs to be calculated for the safety of the member; its value indicates the condition the material is in at this point according to the stress-strain diagram (Figure 4).

The two characteristic points of the tension branch 0 - A of this diagram, viz., σ_{pz} , ϵ_{pz} ; σ_{fz} , ϵ_z —corresponding to the limit of "proportionality" (or "elasticity") and the "yield point"—as well as the limit of the

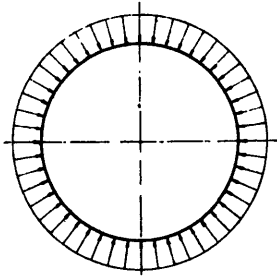

Figure 1 - Diagram Illustrating the Load on a Circular Ring or Tube under Uniform External Pressure

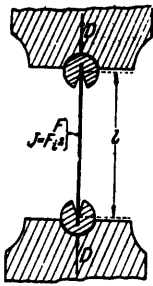

Figure 2 - Diagram of a Rod under Compression with Hinged Bearings

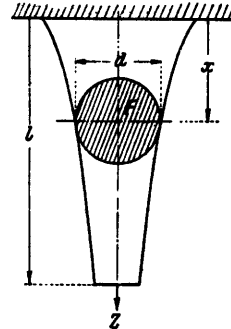

Figure 3 - Diagram of a Rod under Tension with Varying Cross Section

"maximum tensile stress" $\sigma_{\max z}$ call for the differentiation of three cases according to whether

- 1) $0 < \sigma_z < \sigma_{pz}$ [1.1]
- 2) $\sigma_{pz} < \sigma_z < \sigma_{fz}$ [1.2]
- or 3) $\sigma_{fz} < \sigma_z < \sigma_{\max z}$ [1.3]

By introducing the "factors of safety" S_{pz} , S_{fz} and $S_{\max z}$ as defined by the quotients σ_{pz}/σ_z , σ_{fz}/σ_z and $\sigma_{\max z}/\sigma_z$ "against reaching the limit of proportionality, the yield point or the limit of maximum tension respectively," we may also write:

- 1') $S_{pz} > 1$ [1.4]
- 2') $S_{fz} > 1$ [1.5]
- 3') $S_{\max z} > 1$ [1.6]

For adequate safety of the tie-rod it is generally necessary to require that Equation [1.5] shall be satisfied, at least for the maximum load to be carried. Otherwise the bar would exhibit a considerable elongation from its original shape after removal of the load, or, in the case of a subsequent return to this load, its length would again increase (except in special cases). This condition would not be acceptable, in general, in view of the requirements to be placed on the structural elements; (see Pietzker, Die Festigkeit der Schiffe, Berlin 1914, pp. 1-4 and p. 61 to whose ideas we

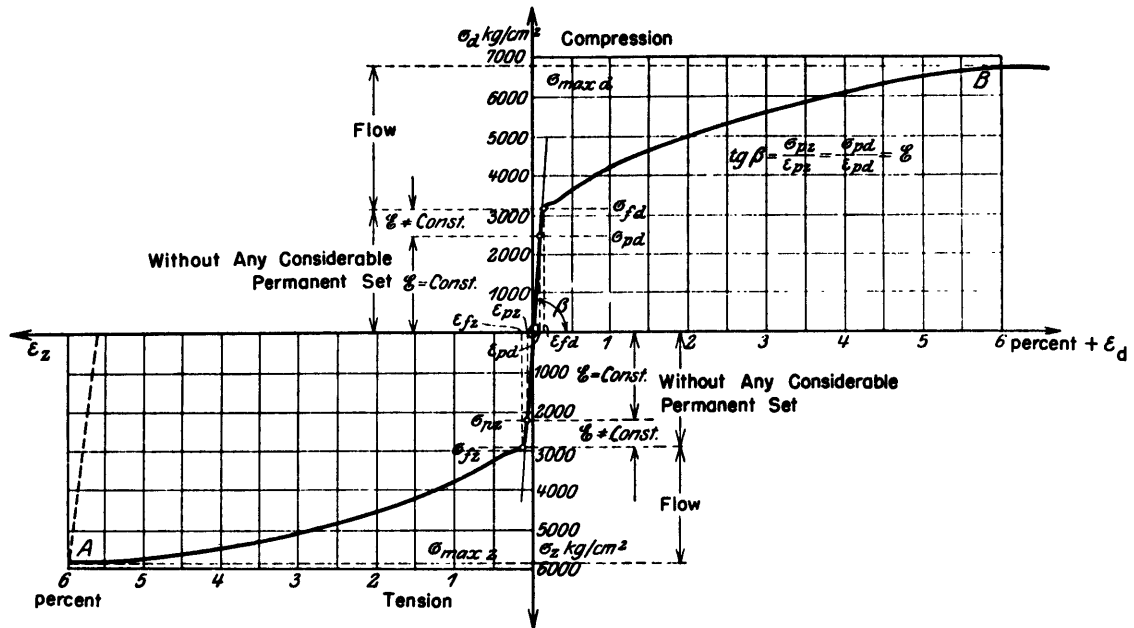

Figure 4 - Stress-Strain Diagram

shall fully subscribe in the following discussion; furthermore, Love-Timpe, Elasticity, Teubner 1907, p. 144).

Note: In pure tension, therefore, the following factors were of no importance as far as safety is concerned:

- a. among the geometrical data the contour form of the sections, their surface moments of the third and fourth longitudinal dimensions (moment of resistance and moment of inertia), and the length of the rod. Only the area of the section at any point is of importance;
- b. among the material data the magnitude of the modulus of elasticity E and Poisson's ratio m ; it is sufficient to know the value of σ_{fz} ;
- c. the nature and magnitude of the elastic displacements Δx and Δd (see Figure 3), where x is measured along the length and d along the diameter;* these may, however, if desired, be determined from:

*See Hovgaard, Memorandum No. 88, p. 5

$$4) \quad \Delta x = \int_0^x \epsilon_z dx \quad [1.7]$$

and

$$5) \quad \Delta d = \frac{\epsilon_z}{m} d \quad [1.8]$$

Specifically, if $S_{pz} > 1$, E is constant, hence

$$\epsilon_z = \frac{\sigma_z}{E} = \frac{Z}{EF} \quad [1.9]$$

and if, in addition, F is constant also,

$$4') \quad \Delta x = \frac{Zx}{EF} \quad [1.10]$$

- d. If the rod which is assumed to be "straight" deviates more or less from the geometrically exact form—as it always does in reality—, i.e., if the sequence of the centers of gravity of the sections do not form a straight line, bending stresses will occur at first (see Figure 5).

As a result of these the stress $\sigma_z = Z/F$ in the extreme fibre F_1 located on the inside of the curvature will be augmented by a certain amount $\Delta\sigma = Z : e/W$ where W is the section modulus,* and e denotes the eccentricity.

If specifically, $S_{fz} = \sigma_{fz}$; Z/F equals or is only a little less than unity, the yield point will be exceeded in the extreme

fibre F_1 at the same time; however, the flow which then occurs will tend to cause an approach

to the straight form and therewith a reduction in the bending portion of $\Delta\sigma$ of the total tensile stress; this process continues until the yield is reached again—from above as it were—in which case the desired condition $S_{fz} = 1$ is attained.

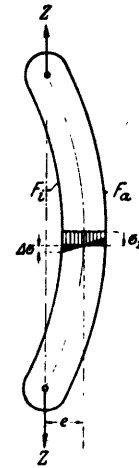

Figure 5 - Diagram Illustrating, a Not-Exactly-Straight Rod under Tension

*See Hovgaard, Memorandum No. 88, p. 5

It is probably correct to consider this process as the last phase of the working of the material; at any rate, in most processes of working the material, the yield point is greatly exceeded, but we do not hesitate thereafter to apply the usual strength formulas to the material, see Pietzke *ibid.* Intentionally, we shall not enter here into discussing the case of the eccentric application of force upon the exactly straight rod.

When a straight rod is under compression, the conditions are very different. The compression branch 0 - B of the stress-strain curve (Figure 4) differs somewhat from the tension branch so that we have to note explicitly that with

$$10) \quad \sigma_d = \frac{D}{F} \quad [1.11]$$

the conditions become

$$11)11') \quad 0 < \sigma_d < \sigma_{pd} \quad \text{OR} \quad S_{pd} > 1 \quad [1.12]$$

$$12)12') \quad \sigma_{pd} < \sigma_d < \sigma_{fd} \quad \text{OR} \quad S_{fd} > 1 \quad [1.13]$$

$$13)13') \quad \sigma_{fd} < \sigma_d < \sigma_{\max d} \quad \text{OR} \quad S_{\max d} > 1 \quad [1.14]$$

But apart from this fact, it is, indeed, necessary though fundamentally insufficient for the safety of the compressed rod to satisfy Equations [1.12] and [1.13]. We shall hereafter designate as "stress calculations" those calculations which lead to equations of the form $\sigma_d = D/F$ according to which specific loads per unit area, i.e., "stresses" are calculated from given external forces in conjunction with the geometrical data of the loaded body in order to compare them with those considered permissible according to the tension and pressure test; in contrast to these, we have "the stability or collapse calculations" the nature of which will be explained later on. It is characteristic of the former that to the stresses there always correspond definite numerical conditions of deformation which in difficult cases must first be fully determined before the stresses can be found.

For those special cases where the stresses can be determined without prior investigation of the elastic displacements, no obstacles stand in the way of determining the condition of deformation.

Accordingly, the following principle holds true: for the straight rod under compression the stress calculation is not in general sufficient; a stability calculation must also be made; the physical reason for this is as follows:

In the case of the exactly straight rod under compression and under a precisely centric load, there are in general two possible conditions of equilibrium for a given compressive force: one representing the reverse of the state of the same rod under tension where the neutral axis remains straight, the other comprising a whole class where the axis of the rod bends outward in different ways (Euler 1744), see Figure 6.

At first it remains undetermined which condition of equilibrium will occur. From the class of conditions involving bars with a curved axis Euler singled out the case of minimum deflection as the only significant one for judging the "stability of a column": he found that the neutral axis in this case followed a sinusoidal curve. Also, he determined (1788) the minimum length which a column of uniformly congruent cross section and of given material must have for a given load in order that a state of equilibrium of the second sort (yielding to axial compression) shall be possible, besides that of the straight form: In this case

A. only the possibility of collapse or condition of instability is determined and the sinusoidal shape of the neutral axis is found. The greatest deflection y_{\max} , however, remains basically indeterminate*—at least in the case of truly axial load. For this reason

B. it is impossible to calculate the "stresses" actually existing in the curved state corresponding to a given load D .

A and B are characteristic of the calculations of the kind which are hereafter designated as "stability calculations" in contrast to "stress calculations". (In stressing this contrast, we shall not deny that the boundary line between the two methods of calculation may be more or less vague; for the problems to be dealt with here, however, it is always sharply defined and recognition of the contrast referred to is of great importance.)

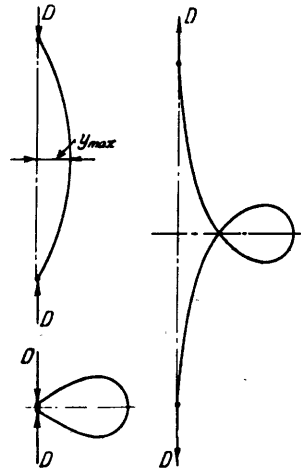

Figure 6 - Sinusoidal Deflection of the Neutral Axis of the Rod ("Elastica")

*Annotator' Note: Such a result is obtained because only an approximate expression is used for the curvature. When the exact expression for the curvature is used, a definite value (in terms of an elliptic integral) is obtained for the deflection. See "Theory of Elastic Stability," by S. Timoshenko, McGraw-Hill Book Company, New York, 1936, pp. 69-74.

Th. von Kármán in his research papers, published by V.D.I., No. 81, 1910, has thoroughly explained—both theoretically and experimentally—"... the problem of buckling which for a long time was a difficult point in the practical theory of collapse of the straight rod." His most important results as far as the present investigation is concerned are the following:

a. Euler's formula holds good only as long as Equation [1.12] is satisfied, i.e., only under the condition that the limit of proportionality would not be exceeded if the rod were artificially prevented from collapse. Within this limit, however, it yields correct results.

b. For $S_{pd} > 1$, the new extended Euler's formula proposed by v. Kármán applies in which E is replaced by a general modulus M . (E_{l-y} = modulus between elastic limit and yield point - Hovgaard, Memorandum No. 88, p. 8).

We shall designate the "critical" or "collapsing" load whether determined by Euler's or v. Kármán's formula by D_k and the quotient

$$16) \quad S_k = \frac{D_k}{D} \quad [1.15]$$

we define as "safety against collapse."

We now supplement the characteristics of stability calculations which were stated above under A and B by the following:

C. The value of the modulus of elasticity which appears very seldom and is of slight importance in stress calculations is in stability calculations determinative.

D. If nothing special is said, stability calculations yield correct results* only as long as the stress calculation to be carried out for a given case shows that the limit of proportionality is not exceeded at any point of the structure or that it would not be exceeded if the collapse were prevented by some special means. If this limit is exceeded, the attempt must be made to apply v. Kármán's method to the case.**

In order to make this point quite clear, the entire range of tensile and compressive loads attainable without permanent changes of form in a straight rod of Martin steel of 2.5 x 4 cm transverse dimensions and of different lengths has been represented in Figure 7 making use of the results presented by v. Kármán.

Annotators' Notes:

*Theoretical analyses of stability problems nearly always presuppose that the member is free of any initial eccentricities from its given initial configuration. Also, in the case of straight bars, for example, it is assumed that the compressive load is applied without any eccentricity.

**This method is discussed in detail by F.R. Shanley, "Inelastic Column Theory," Journal of the Aeronautical Sciences, May 1947, pp. 261-268.

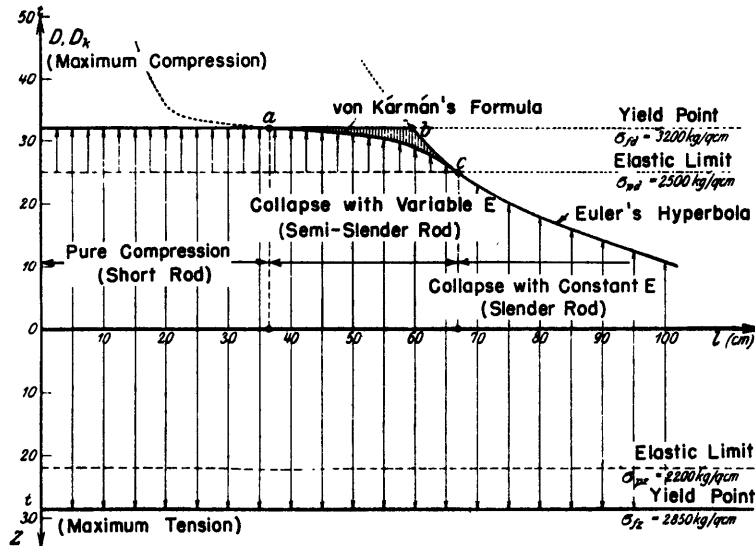

Figure 7 - Limit of Tensile and Compressive Loads Attainable in a Straight Rod of Martin Steel of 2.5 x 4 cm Transverse Dimensions and of Different Lengths

In tension we have for all lengths of rod simply $\sigma_z < \sigma_{fz}$, thus $Z < 28.5$ tons (see lower part of Figure 7); but in compression this condition can be reversed only for "short" rods (up to $l = 36.5$ cm) and for these D must be smaller than 32 tons. With increasing length we reach the region of "semi-slender" rods (36.5 to 67 cm) where the maximum compressive load according to the curve a-c falls off to 25 tons. The form of the curve a-c depends entirely on the properties of the respective material; its construction presupposes the exact knowledge of the stress-strain diagram. Beyond $l = 67$ cm, i.e., for "slender" rods, Euler's "hyperbola" is valid:*

$$16)16') \quad D_k l^2 = \pi^2 E J = \pi^2 E \frac{4 \cdot 2.5^3}{12} = \text{constant} \quad [1.16]$$

If we disregard the investigations of v. Kármán in the case of non-slender rods ($l < 67$ cm), we can only be safe if we adopt 25 tons as the limiting load. In reality, however, loads as much as 28 percent higher (32 tons) can be attained.** If we use Euler's formula up to the yield point,

Annotators' Notes:

*An analogous relationship has been proposed in the study of the hydrostatic collapsing pressure of a thin cylindrical shell. A "pressure factor" ψ and a "thinness factor" λ are used as coordinates in plotting this relationship. This idea was introduced by D.F. Windenburg and C. Trilling in U.S. Experimental Model Basin Report 385, "Collapse by Instability of Thin Cylindrical Shells under External Pressure," July 1934.

**A load of 32 tons could be attained only by using a rod 36.5 cm in length.

we would substitute the straight line a-b and the curved piece b-c for the curve a-c. It is true that the maximum error would not be very serious in cases where a high factor of safety is used; yet in regard to submarine design it is of interest to know whether—comparatively speaking—the first permanent set in the structure occurs at a depth of immersion of 32 m or at 29.5 m.*

We shall now continue with the characterization of the collapse calculations:

E. The initial deviations from the exact geometrical form, where cases of collapse are to be taken into account, have a tendency to increase immediately; hence, in practice, viz., in shipbuilding generally, we cannot allow the limit $S_k = 1$ to be reached. Since the original deviations from the ideal form always depend on the manufacturing process used in each case (irregularities in manufacture and construction**) and since they determine the earlier or later occurrence of collapse, it is fundamentally impossible to make a generally valid statement regarding the permissible factor of safety. Even model tests can be used only if extensive precautionary measures are taken;*** only experiments to full scale can give reliable results.

F. The assumed process of deformation on which collapse calculations are based is in a certain sense one of instability in that at first no deflection whatever occurs when the load increases gradually, but suddenly, at a certain limiting load, a very pronounced and steadily increasing deflection occurs.† As observation shows this is not in general what happens in practice: even at the smallest loads elastic deflections occur, increasing in approximately the same proportion as the load. When a certain limiting load has been exceeded, the material begins to flow and a considerable part of the total deformation which has occurred no longer vanishes after the load is removed. If the load is still further increased despite the fact that this

*Annotators' Note: This is apparently a misprint as it is evident that the author intended to give a value of 25 m.

**See Hovgaard, Memorandum No. 88, p. 9.

***Annotators' Note: In the light of existing knowledge it would appear that any irregularities occurring in the model would have the same effect upon it as corresponding scaled irregularities occurring in the prototype would have upon that structure.

†Annotators' Note: This explanation is based upon an analysis using so-called "small deflection theory," in which only an approximate expression is used for the curvature of the bar. If the exact expression for curvature is utilized, the analysis is then valid for deflections of any magnitude. Examination of this more precise theory (loc. cit. Timoshenko, p. 9) indicates that there is actually a determinate deflection normal to the undeflected position of the bar for all values of the axial compressive load.

limit has been exceeded, more or less violent and destructive deflections occur, but these lie then far above the permissible "working loads" and do not differ fundamentally from phenomena of crushing.

G. A stability calculation, therefore, does not represent the physical process actually occurring as in the case of a stress or strain calculation; instead, since a calculation taking into account all irregular influences is impossible, it substitutes for the actual conditions a greatly idealized limiting case, which is very much exaggerated geometrically, thus throwing the entire uncertainty of the process on to a factor of safety which must be determined in each particular case.

H. Stability calculations, therefore, involve mathematically refined methods which, although a priori abandon all claim to a complete solution of the problem, nevertheless afford a deep insight into the mechanism of the process. They make it possible to reduce to a minimum the number of the factors which are to be investigated experimentally; besides, they permit a rational classification of the observed phenomena which have hitherto appeared quite incoherent and often contradictory. They are, indeed, well suited to meet the needs of engineering practice, for they lead directly to experimental research which becomes indispensable again and again, and thus they have become an inexhaustible source of further knowledge. This is especially true in the problem of the buckling resistance of two-dimensional structural parts (sheet iron covers and bottoms).

2. THE CIRCULAR RING OR FRAME

a. UNIFORM INTERNAL PRESSURE p_1

Let the "neutral axis" n , i.e., the loci of the centers of gravity of the cross-sectional areas of size F which are everywhere congruent, form a circle with the radius r ; let the transverse dimensions b and h of the ring be small relative to r . In the ring, which is assumed to carry a load p_1 (in kg per cm of length of the neutral axis) which is of the same magnitude at each point and directed radially outwards, there exists then at each section a pure tensile stress as in the case of the straight rod; its magnitude is

20)

$$\sigma_z = \frac{r p_1}{F}$$

[2.1]

and the safety of the ring must be judged by comparing this value with σ_{pz} , σ_{fz} , and $\sigma_{\max z}$. In general, the maximum permissible internal pressure amounts to

$$22) \quad p_{i \max} = \frac{F}{r} \sigma_{fz} \quad \text{ie. } p_m = \frac{2h}{D} \sigma \quad [2.2]$$

Note:

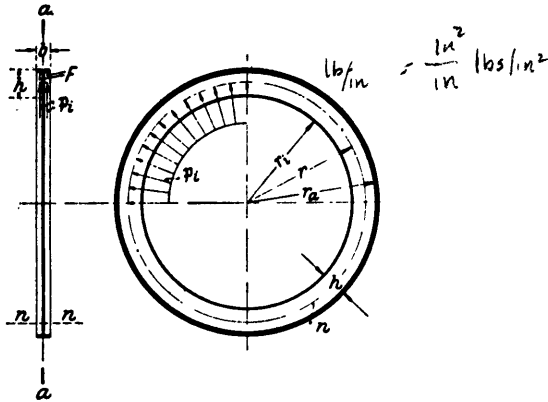

Figure 8 - Circular Ring or Frame under Internal Pressure p_i

It is assumed here that the load p_i results from the reduction of the pressures generally acting on the flange F. In those cases which are important for us, these pressures are distributed symmetrically with respect to the plane a-a and their replacement by p_i alone is permissible only when the ring profile is likewise symmetrical with respect

to a-a as drawn in Figure 8. Otherwise a twisting moment would also occur. However, since the unsymmetrical cross section is found much more frequently (angle iron, bulb angle iron), a certain theoretical error is involved here; yet thus far this has not noticeably affected the practical applicability of the formulas given later on.

At the same time, due to the influence of the load, the ring suffers a deformation changing as a result into a circular ring with the radius $r + y_0$. In general,

$$24) \quad y_0 = \int_{\varphi=0}^{\varphi=r} \epsilon_z d\varphi \quad [2.3]$$

and in the special case $\delta_z < \sigma'_{pz}$

$$24') \quad y_0 = \frac{r^2 p_i}{E F} \quad [2.4]$$

At the same time, the transverse dimensions of the ring are reduced by the amounts

$$25) 25a) \quad \Delta h = \frac{\epsilon_z}{m} \text{ and } \Delta b = \frac{\epsilon_z}{m} b \quad [2.5]$$

What was said about the straight rod in tension in paragraphs a to d holds true also in the case of the ring if applied logically. (The restriction that the cross section must be of the same dimensions everywhere and symmetrical with respect to a-a was already made above).

b. UNIFORM EXTERNAL PRESSURE p_a

In analogy with the straight rod under compression, the requirement

$$32) \quad p_a < \frac{F}{r} \sigma_{rd} \quad [2.6]$$

is necessary here also but is not sufficient since in general a second configuration of equilibrium (in addition to that of the circle) is possible (see Figure 9); this occurs as soon as $p_a > p_k$ where

$$36) \quad p_k = \frac{3 E J}{r^3} \quad \text{ie} \quad \frac{24 E I}{D_o^3} \quad [2.7]^*$$

specifically for a ring of rectangular section, of radial depth s and width l cm, we have

$$36') \quad p_k = \frac{E}{.4} \left(\frac{s}{r} \right)^3 \quad \dots (s < l) \quad [2.8]$$

This formula, which in shipbuilding is frequently attributed to Föppl—apparently in connection with the treatise by Hurlbrink (Schiffbau 1908, p. 606), was the subject of numerous investigations even in the early eighties of the last century; the starting point of these seems to have been the treatise by J. Boussinesq entitled "Résistance d' un anneau à la flexion"

(Resistance of a Ring against Bending), Comptes Rendus 1883. In accordance with general practice we shall hereafter designate the quotient

$$37) \quad S_f = \frac{p_k}{p_a} \quad [2.9]$$

as the "Föppl factor of safety" and point out that the observations made in

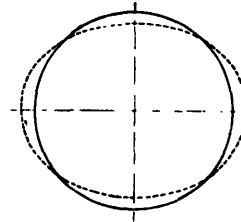

Figure 9 - Circular Ring Becoming Oval (Collapsing) under Uniform External Pressure

*Annotators' Note: This formula is usually attributed to M. Lévy, "Mémoire sur un nouveau cas intégrable du problème de l'élasticité et l'une de ses applications," Journal des Math. pures et appl., (Liouville), ser 3 to 10, 1884, pp. 5-42. It is to be noted that this expression presupposes a two lobe mode of collapse.

regard to the straight rod under compression (see A to H) hold true also in the case of the ring if applied logically.

To illustrate this, let us consider, in analogy with a straight rod of variable length as in Section 1, a circular ring of rectangular section of 1 cm width and thickness s cm. Let the circular ring consist of the same material as the rod and let it be loaded, once by internal and then by external hydraulic pressure, up to the limit to which it remains free from any appreciable permanent deformations. Curves for the entire range of the maximum pressures attainable under this assumption are plotted in Figure 9a.

For an internal pressure with $F = 1 \text{ cm} \cdot s$ according to Equation [2.2] we have

$$p_i \cdot 1 \text{ cm} = p_i \quad [2.10]$$

$$p_{i \text{ max}} \frac{r}{s} = \sigma_{fz} = 2850 \text{ kg/qcm} \quad [2.11]$$

i.e., p_i is plotted as the equilateral hyperbola $\sigma_{fz} = 2850$ drawn in solid lines while the hyperbola $\sigma_{pz} = 2200$ drawn in dotted lines corresponds to the limit of proportionality.

For external pressures the mere reversal of this condition is valid only in case of "thick" rings up to $r = 6.3 s$. For these, the hyperbola

$$p_{a \text{ max}} \frac{s}{r} = \sigma_{fd} = 3200 \text{ kg/qcm} \quad [2.12]$$

is considered to be the limit. (We shall here disregard the fact that, strictly speaking, our formulas are no longer valid for very thick-walled rings, since it is assumed that, b and h are small relative to r ; we are merely interested in the illustration here).

When r/s increases further, we enter the region of "semi-slender" rings, extending from 6.3 to 14.7, where the maximum attainable external pressure drops below the values of the hyperbola and follows the curve a-c. In order to make the figure clearer in the region a-b-c, all curves have also been plotted with each ordinate increased five-fold. (The right hand scale is then used.) At the point c, the hyperbola $\sigma_{pd} = 2500$, i.e., the limit of proportionality has been reached and from here on, in the region of thin rings, the maximum external pressures attainable follow Föppl's formula. According to Equation [2.7], if we use the previously introduced p instead of p , we have

$$p_{a \text{ max}} = \frac{E}{4} \left(\frac{s}{r} \right)^3 \quad [2.13]$$

or

$$p_{a \text{ max}} \left(\frac{r}{s} \right)^3 = \frac{E}{4} = \text{constant} \quad [2.14]$$

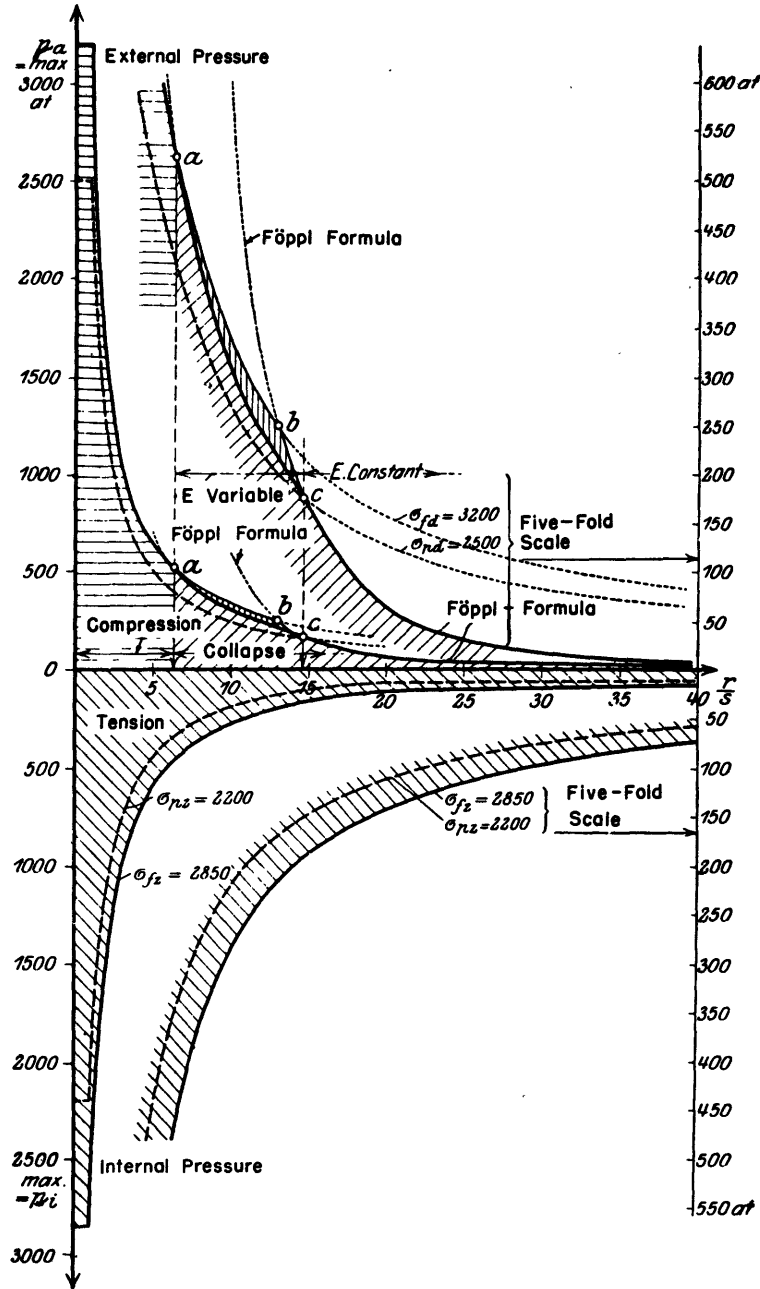

Figure 9a - Limits of the Internal and External Pressures for a Circular Ring of Martin Steel as a Function of the Ratio of the Radius of the Ring to Its Wall Thickness

i.e., a sort of hyperbola of the fourth degree. If we ignored v. Kármán's theory, we would be safe only if we permitted for all "thick" and "semi-slender" rings only the hyperbola $\sigma_{pd} = 2500$ as limiting pressure curve. In reality, however, considerably higher pressures are attainable; for example, for $r/s = 6.3$ a pressure of 520 atm. as compared with 410 atm., i.e., 27 percent more is attainable. If the Föppl formula were simply

extrapolated up to the yield point, this would be equivalent to replacing the curve a-c by the curve a-b-c. Then, for the point b ($r/s = 13$), a pressure of 250 atm. would result whereas actually only 220 atm. are attainable.

3. UNSTIFFENED CYLINDRICAL TUBE OF INFINITE LENGTH

a. UNIFORM INTERNAL PRESSURE p_i

Using the designations of Figure 10 and assuming that s is small relative to r and that, consequently, $r_1 \cong r$, the tangential tensile stress existing at every point becomes

$$40) \quad \sigma_z = \frac{r p_i}{s} \quad [3.1]$$

and the maximum internal pressure permissible is

$$42) \quad p_{i \max} = \frac{s}{r} \sigma_{fz} = \frac{2h}{D} \sigma_y \quad [3.2]$$

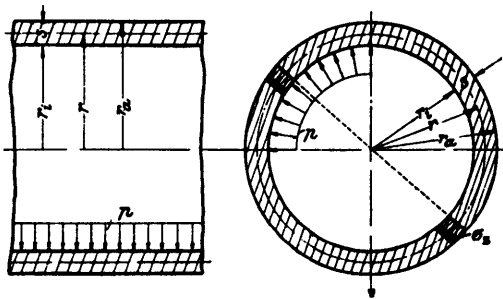

Figure 10 - Designations for the Frameless Tube of Infinite Length

At the same time the tube is subject to various deformations due to the influence of the internal pressure. These consist of

A. an increase in the diameter $2(r + y_\infty)$, where

$$44') \quad y_\infty = \epsilon_z r = \frac{\sigma_z}{E} r = \frac{r^2 p_i}{E s} \quad [3.3]$$

B. a reduction in thickness of the shell s by the amount

$$45) \quad \Delta s = \frac{\epsilon_z}{m} s = \frac{\sigma_z}{m E} s = \frac{r p_i}{m E} \quad [3.4]$$

C. a longitudinal contraction corresponding to

$$45a) \quad \epsilon_z' = \frac{\epsilon_z}{m} = \frac{1}{m E} \cdot \frac{r}{s} p_i \quad [3.5]$$

~~Those parts of Equations [3.3] to [3.5] which contain the factor E are valid only below the elastic limit and only as long as the tube is free to contract longitudinally or as long as no longitudinal stresses of any kind (parallel to the cylinder axis) exist for some reason or other. If the tube is forcibly~~

prevented from contracting longitudinally, the value

$$\epsilon_z^0 = \frac{m^2 - 1}{m^2 E} \sigma_z = \frac{m^2 - 1}{m^2 E} \cdot \frac{r}{s} p_i \quad [3.6]$$

is introduced for ϵ_z in those equations and, as a result, we obtain

$$y_\infty^0 = \frac{r^2 p_i}{E s} \cdot \frac{m^2 - 1}{m^2} \quad [3.7]$$

The longitudinal stress resulting at the same time is

$$\sigma_z^0 = \frac{m E}{m^2 - 1} \epsilon_z^0 = \frac{1}{m} \cdot \frac{r}{s} p_i \quad [3.8]$$

The factor $m^2 E / (m^2 - 1)$ which occurs in Equation [3.7] in place of E in Equation [3.3] is a quantity which is characteristic of all elastic calculations of two-dimensional conditions; its origin and significance will be discussed later on (see Section 4 and compare also Love-Timpe, p. 553*). Here we are satisfied to state merely that the factor $(m^2 - 1)/m^2$ equals 0.91 for the value $m = 10/3$ which is valid in case of metals; hence, both ϵ_z^0 as well as y_∞^0 are 9 percent smaller than in the free tube (with ends not held longitudinally) while the stress σ_z remains unaltered (Equation [3.1]), a result which necessarily follows from the static conditions.

In any event, the statements made in regard to the straight rod in tension (see a to d) hold true here as in the case of the circular ring if applied logically.

b. EXTERNAL PRESSURE p_a

In analogy to the conditions prevailing in the case of the straight rod under compression and the circular ring under external pressure the requirement

$$p_a < \frac{s}{r} \sigma_{fd} \quad [3.9]$$

obtained by reversing Equation [3.2] is again necessary, but fundamentally not sufficient since in general a second configuration of equilibrium exists

*After this article had been printed, there appeared the book "Drang und Zwang," an advanced treatment of the science of strength of materials for engineers by A. and L. Föppl, Vol. 1, where the difference between the conditions of elastic equilibrium on which the Equations [3.3] and [3.7] are based, is discussed in full (p. 86 and most of the following). The reader is urged to refer to this publication for further details.

(Figure 9), viz., when $p_a > p_k$, where

$$56) \quad p_k = 3 \frac{\frac{m^2 E}{m^2 - 1} \cdot \frac{s^3}{12}}{r^3} = \frac{1}{4} \cdot \frac{m^2 E}{m^2 - 1} \left(\frac{s}{r}\right)^3 \quad [3.10]$$

(Bresse 1829; see also Love-Timpe, p. 637).

Equation [3.10] differs from Equation [2.7], which applies to the circular ring only, by reason of the fact that E has been replaced by $m^2 E / (m^2 - 1)$, a factor which has occurred before in Equation [3.7]. However, Equation [3.10] like Equation [3.7] is valid only when the tube is restrained against any longitudinal change of form. There are, indeed, cases where this condition is satisfied quite accurately; for example, consider a fire tube of a steam boiler. This case may be contrasted to that of a tube that is completely free to expand, or a tube that is closed at both ends and subjected to axial pressure. However, the attempt to apply Equation [3.10], which for a long time was the only mathematical formula for collapse of cylindrical shells under external pressure, to steam boiler tubes failed because it would have been necessary for the tubes

- A. to be absolutely free to deform in the radial direction, also at the tube ends (see Figure 9);
- B. to have at the same time a constant length to be maintained by axial reactions.

However, such a case can hardly be realized in engineering practice. This problem which Love and other authors tried to deal with by setting up empirical formulas based on experiments was solved by the fundamental investigations of R. v. Mises (Z.V.D.I. 1914, p. 750). He treated the case of a tube reinforced by transverse stiffeners fitted at a certain distance l apart from one another, as indicated in Figure 11.

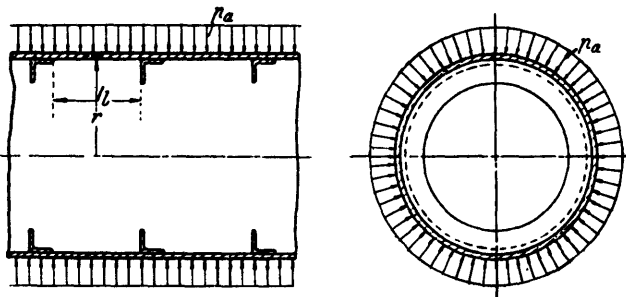

Figure 11 - Cylindrical Tube Fitted with Transverse Stiffeners (Strength Hull)

In the case of tubes reinforced in this manner two important cases are to be distinguished according to whether the tube is free to expand or contract longitudinally (see Section 4) or whether it is closed at the ends by bulkheads, Figure 12, so that the total pressure $\pi r^2 p$ is acting at each end (see Section 5).

The formulas of Section 3, on the other hand, represent an important preliminary step both from the point of view of the historical development as well as for the understanding of the problem involved, however small their practical importance may be today.

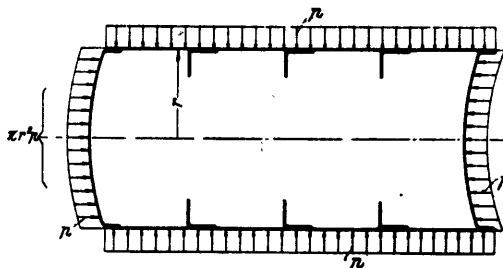

Figure 12 - Submerged Body Fitted with Frames and Ends

4. THE FREE CYLINDRICAL TUBE STIFFENED BY TRANSVERSE FRAMES

a. UNIFORM INTERNAL PRESSURE p_1

If we assume the frames q to be equidistant from each other, the shell W bulges out between the frames and assumes a bulbous shape (see Figure 13); the deformation diagrams between two adjacent frames are congruent to each other with the shell presumed to be clamped at the frames.

The analogous case of a straight bar is that of a beam of uniform section clamped at the ends and subjected to a uniform load (see Figure 14). The support may be rigid or uniformly yielding.

We shall once more discuss this case fundamentally in order to make it easier to understand the subsequent calculations for the two-dimensional problems of the tube.

A. The method of calculation common in mechanics starts out with the general elasticity equation

a)
$$\frac{M}{EJ} = -\frac{1}{\rho} \quad [4.1]$$

upon which even Euler's formulas for collapse were based. Specifically, for the rod of rectangular section of width unity and height s the equation

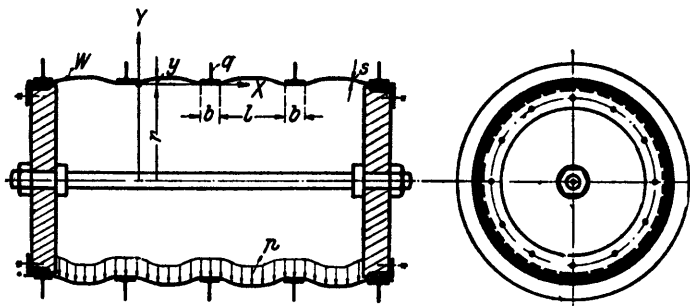

Figure 13 - Tube Free to Expand and Contract Axially and Fitted with Transverse Frames

$$a_0) \quad M = -E \frac{s^3}{12} \cdot \frac{1}{\rho} \quad [4.2]$$

would apply. This equation represents a hypothesis with respect to the relationship between the static quantity "bending moment M " and the geometric quantity "curvature $1/\rho$ " on the right side, where

$$b) \quad \frac{1}{\rho} = \frac{d^2 y}{dx^2} \quad [4.3]$$

(a purely geometric relation). On the left side, however, M is obtained by static methods (summation of moments at any given cross section) as a function of x ; for a constant p we obtain

$$c) \quad M = M_A - A x - \frac{p x^2}{2} \quad [4.4]$$

where M_A , the moment at the support, and A , the shearing force at the support at the point $x = 0$, are at first unknown. Otherwise M is a known function of x .

The signs are so chosen (see Figure 14) that the "bending moment at the point x " is that moment which the part of the beam to the left of that point (with smaller values of x) exerts on the part to the right of that point (with the greater values of x); moreover, this moment is taken to be positive in that direction in which the x -axis when turned most quickly reaches the y -axis (in Figure 14, the clockwise direction). Figure 14 shows how the signs of the reactions at the support and of the shearing forces are selected; they are taken to be positive in the direction of the positive y -axis.

Equation [4.3] substituted in Equation [4.1] gives

$$I') \quad \frac{d^2 y}{dx^2} + \frac{M}{EJ} = 0 \quad [4.5]$$

and after substitution from [4.4]

$$I'') \quad EJ \frac{d^2 y}{dx^2} - \frac{p x^2}{2} - A x + M_A = 0 \quad [4.6]$$

Hence, with constant EJ , we get by integration

$$I_1'') \quad EJ \frac{dy}{dx} = \frac{p}{2} \cdot \frac{x^3}{3} + A \frac{x^2}{2} - M_A x + EJ y_0' \quad [4.7]$$

and finally

$$I_2'') \quad EJ \cdot y = \frac{p}{6} \cdot \frac{x^4}{4} + \frac{A}{2} \cdot \frac{x^3}{3} - M_A \frac{x^2}{2} + EJ y_0' x + EJ y_0 \quad [4.8]$$

The four constants A , M_A , y_0' , y_0 , which are unknown here and of which only the first two must be known in order to compute the bending stress of the beam, can be determined as soon as four values of A , M_A , $\frac{dy}{dx}$ or y which are independent of each other are prescribed at certain points. In our example (see Figure 14), both for $x = 0$ and for $x = l$ we must have $\frac{dy}{dx} = 0$ and $y = 0$. For these boundary conditions there results from Equations [4.8] and [4.7]:

$$0 = y_0 \quad [4.9]$$

$$0 = y_0' \quad [4.10]$$

$$0 = \frac{p}{6} l^3 + \frac{A}{2} l^2 - M_A l = \frac{p}{6} l^2 + \frac{A}{2} l - M_A \quad [4.11]$$

$$0 = \frac{p}{24} l^4 + \frac{A}{6} l^3 - \frac{M_A}{2} l^2 = \frac{p}{12} l^2 + \frac{A}{3} l - M_A \quad [4.12]$$

$$0 = \left(\frac{1}{6} - \frac{1}{12}\right) p l^2 + \left(\frac{1}{2} - \frac{1}{3}\right) l A$$

$$\underline{A = -\frac{p l}{2}}, \quad \underline{M_A = \frac{p l^2}{12} - \frac{p l}{2} \cdot \frac{1}{3} = -\frac{p l^2}{12}},$$

Thus the unknown moment M_A is determined. Now A and M_A are still to be inserted in Equation [4.4]:

$$c_1) \quad M = -\frac{p l^2}{12} + \frac{p l}{2} x - \frac{p}{2} x^2 \quad [4.13]$$

and from this the maximum value of M is to be determined which will be $M_{\max} = M_A = M_B$. Finally, we obtain

$$\sigma_{b \max} = \sigma_{b A} = \sigma_{r B} = \frac{M_A}{W} = \frac{p l^2}{12 W}, \quad [4.14]$$

where W designates the moment of resistance of the cross-sectional area (section modulus); specifically for a rectangular section of width l and height s ,

$$\sigma_{b \max} = \frac{p}{2} \left(\frac{l}{s}\right)^2. \quad [4.15]$$

If, in addition, it seems desirable to know the maximum deflection, the A , M_A ; y_0' and y_0 are to be substituted in Equation [4.8] from which $y = f(x)$ is fully known. We obtain

$$E J \cdot y = \frac{p}{24} x^4 - \frac{p}{12} l x^3 + \frac{p}{24} l^2 x^2 \quad [4.16]$$

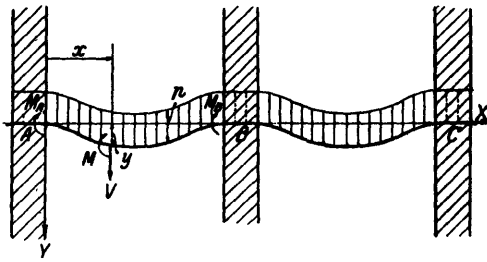

Figure 14 - Continuous Beam
under Uniform Load

It is advantageous to use the symmetry imposed on the problem by the boundary conditions and to rewrite the Equation [4.16] in such a manner that this symmetry can be recognized.

If it is considered that the elastic curve must be symmetrical with respect to the ordinate $x = l/2$ (Figure 14) and that therefore the same value of

y must be obtained if $l - x$ is substituted for x , then the Equation [4.16] may also be written in the form

$$I_{22}'''' y = \frac{p}{24} x^2 (l - x)^2 \quad [4.17]$$

from which the desired objective and, at the same time, the most concise form is obtained. In a similar manner we may write for Equation [4.13]

$$c_2) \quad M = -\frac{p l^2}{12} + \frac{p}{2} x (l - x) \quad [4.18]$$

B. In the general theory of elasticity, it is customary to reach out a little farther and to advance the integration two steps higher by considering the conditions of equilibrium of an elemental piece of beam of length dx which may be cut out at any point whatsoever, instead of considering those of an element of finite length assumed to be detached from the rest of the beam. This gives (see Figure 15):

$$1) \quad -V + p \cdot dx - V + dV = 0 \quad [4.19]$$

$$\text{hence } \frac{dV}{dx} + p = 0 \quad [4.20]$$

$$2) \quad M + V \cdot dx - M - dM = 0 \quad [4.21]$$

$$\text{hence } \frac{dM}{dx} - V = 0 \quad [4.22]$$

and by elimination of V we get

$$c') \quad \frac{d^2 M}{dx^2} + p = 0 \quad [4.23]$$

Equation [4.23], showing that the moment curve for constant p must be a second degree function of x , may be introduced into the fundamental equation [4.6]

which always holds after the latter has been differentiated twice. We obtain

$$I''') \quad \frac{d^4 y}{dx^4} - \frac{p}{EJ} = 0 \quad [4.24]$$

(at any point x of the beam)

or for a beam of specifically rectangular section (see Equation [4.2] this becomes

$$I) \quad \frac{d^4 y}{dx^4} - \frac{12p}{Es^3} = 0 \quad [4.25]$$

Equation [4.25] is the differential equation of the elastic curve of the straight beam under uniform load: its great advantage lies in its extraordinary generality which is based not only on the arbitrary manner in which p , E , and J may vary with x , but especially upon its unlimited adaptability to conditions of support of any kind whatsoever. Outwardly this is indicated by the fact that it contains only such constants or functions which, like E , s , and p , must be given for the solution of a definite problem whereas unknown supporting moments and reactions no longer exist. "In it, all special conditions of a particular case or problem are eliminated and the typical expression for the entire class of such ... phenomena is obtained" (Hamel, Elementare Mechanik, Teubner 1912, pp. 26 and 42). The individual case is obtained through integration of Equation [4.24] which reduces here to a mere quadruple integration and can always be performed when p , E , and J are given functions of x . In the special case when p , E , and J are constant, we have

$$I_1''') \quad \begin{aligned} EJ \frac{d^3 y}{dx^3} &= \text{shear force with negative sign} \\ &= -V = px - V_A \end{aligned} \quad [4.26]$$

and

$$I_2''') \left. \begin{aligned} EJ \frac{d^2 y}{dx^2} &= \text{bending moment with negative sign} \\ &= -M = \frac{p}{2} x^2 - V_A x - M_A \end{aligned} \right\} \quad [4.27]$$

from which, when V_A is replaced by its equal and opposite bearing reaction at the point A, Equation [4.27] or [4.4] is obtained again as it should be.

From this point on the calculation can be carried on as under A.

It is important to note that in order to find the variation moments it is never necessary to first determine the elastic curve. If, nevertheless, by proceeding according to a purely schematic method $y = f(x)$ were calculated completely in advance and if we went back to find

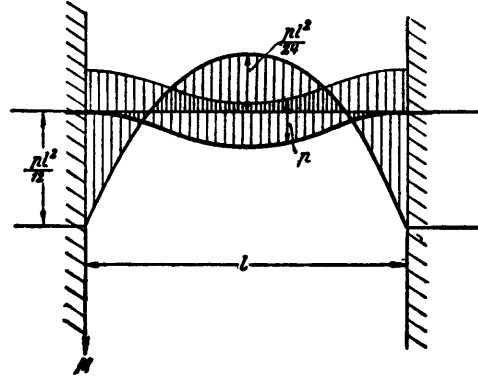

Figure 15 - Straight Rod Clamped at Both Ends (Deflection Curve and Curve of Moments)

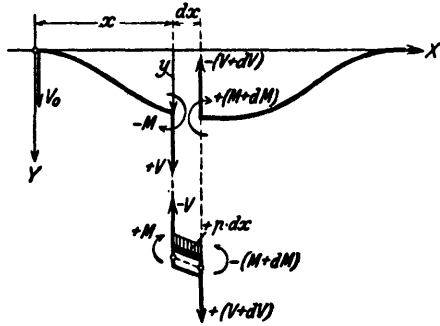

Figure 16 - Bending Moments and Shear Forces in the Case of the Straight Bar

$$M = -EJ \frac{d^2y}{dx^2} \quad [4.28]$$

then this would obviously be a round-about method of calculation. It is best, therefore, as is generally known, to use Equation [4.4] (moment curve) obtained in one way or another, i.e., according to [4.20] or [4.22], and to endeavor to determine directly the two unknown constants A and M_A from the two conditions

$$\int_0^l \frac{M}{EJ} dx = 0 \quad \int_0^l \frac{M}{EJ} x dx = 0 \quad [4.29]$$

expressing the state of the beam at the supports which need not be discussed here in detail.

With respect to our real and more difficult problem concerning the tube stiffened by transverse frames, we must, however, point out the following:

All these methods are based solely on the possibility of integrating Equation [4.23] directly; this equation states that the moment curve must always be a quadratic function of the length of the beam. The nature of the moment curve is therefore independent of the intermediate values of y (at any point x); its location relative to the axis of the beam, however, varies from one problem to another depending entirely on the boundary values of y_0 , y_1 , y_0' , y_1' . If, however, the form of the moment curve depends also on the intermediate values of y —as we shall observe in a tube stiffened by frames—, we must perform the purely mathematical process of complete integration of the differential equation before the moment curve can be found. Such problems may in a certain sense be regarded as statically indeterminate of a higher order. One has, indeed, used the term "statically indeterminate of an infinite order" and this with a certain degree of justification as we shall see later on.

Finally, it is important to note that E had to be constant throughout or at least a known function of x in order to make the integrations possible. From this it follows that for the statically indeterminate beam not only the explicit expressions for the displacements (Equations [1.10], [2.4], [3.3], [4.16]) are correct only up to the elastic limit—as in the case of the straight rod and the ring mentioned previously—, but the same holds true for the expressions for the moments and bending stresses. For if at any one point

of the beam the calculations gave tensile stresses greater than σ_{pz} or compressive stresses greater than σ_{pd} , then, according to the stress-strain curve, the elongations and contractions occurring at these points would not be as calculated and hence also the curvatures $1/\rho$ and therewith the moment curve would finally change too. It is true that the functional character of the moment curve must always remain the same (integration of Equation [4.4]), but its location changes for statically indeterminate problems as compared with the case where $\sigma_b \max < \sigma_f$.

For statically determinate problems where all bending moments, etc., can be fully determined simply from the conditions of equilibrium of the rigid body, quite independent of any hypothesis as to their elastic behavior, the moment curve must, indeed, retain its position beyond the elastic limit; but the extreme fibre stresses corresponding to the individual moments are no longer proportional to the moments. For a statically determinate case, i.e., a beam resting on two supports and loaded by a single load at the middle, E. Meyer, on the basis of the stress-strain curve, calculated the bending stresses from the known moments and from these he finally found the corresponding deflections as functions of the magnitude of the point load (Z.V.D.I. 1908, p. 167).

One interesting and important result of Meyer's is the following:

Even in experiments on bending the elastic deflections show stepwise changes at the elastic limit and at the yield point very similar to those observed in experiments on simple tension and compression. However, if we calculate the "bending stress" corresponding to the yield point on the basis of the ordinary formula set up for $E = 2,200,000$ and therefore no longer valid for our present case, we find, for instance, tensile stresses of 4400 kg/cm^2 for a material of only 3000 kg/cm^2 elastic limit. This fact, which has been fully explained by E. Meyer and which represents an important supplement to the studies by Pietzker regarding the customary exceeding of the yield point in shipbuilding (ibid., p. 2, line 14 from the bottom of the page), is of paramount importance to us. The conclusion is drawn that: "If the bending stresses, calculated on the basis of formulas which in reality are valid up to the elastic limit only, attain values which exceed the limit of elasticity by not too great a percentage, then the deflection is still not much in excess of the linear law; the maximum deflections continue to follow the linear law approximately." Such cases were observed by us also, and the cause of this phenomenon will be discussed later on.

Returning to the problem of the tube stiffened by transverse frames and subject to internal pressure, it is, in view of the foregoing, necessary first to find the elastic curve to which the shell bulges out between the

frames; hence, we must first set up the general differential equation of that curve. As in the case of the straight rod, this is effected by combining three classes of equations, namely:

A class of type (a): Static-geometrical relations between bending moment and curvature (or between tension and elongation);

A class of type (b): purely geometrical relations between the coordinates of the elastic curves on one hand and curvature and elongation on the other;

A class of type (c): purely statical relations: conditions of equilibrium for an element imagined to be detached from the shell of the tube.

In an article by v. Sanden, Z.V.D.I., 1910, p. 2062, these three classes of equations are abstracted from the general theory of thin shells according to Love-Timpe, pp. 586-609, and then applied to the tube which is free from end pressure; the designations adopted there are A, B, and C, respectively. Classes (a) and (b) are represented by six equations each, class (c) by two. As far as necessary, these equations will be noted later on; they differ from those for the straight rod in the following points:

The two equations of class (c):

If (in Figure 17) we imagine a strip of 1 cm width and running parallel to the tube axis x-x to be detached from the adjacent elements of the shell and subjected to the internal pressure p_1 , then this strip will bend out more at each point than if it had remained in contact with the adjacent strips because a deflection y can take place only if there occurs at the same time an expansion y/r of the circular ring intersecting the strip perpendicularly, similar to the case discussed under Section 2 (see Figure 18). In other words: The load p_1 kg exerted on the small square of 1×1 cm is supported both longitudinally and transversely (and herein lies the fundamental static discovery for tubular structures):

1. as in the straight beam, by the bending moments and shear stresses transferred to the supports A and B;

2. as in the circular ring, by circumferential tension in the section S which occurs at the same time, resulting in partial relief of the strip from bending (component $\sigma_2 s/r$ directed radially inwards; see Figure 18).

Hence, instead of Equation [4.4], we obtain

$$C_2) \quad \left(\frac{d^2 M}{dx^2} - \frac{\sigma_2 s}{r} \right) + p_1 = 0 \quad [4.30]$$

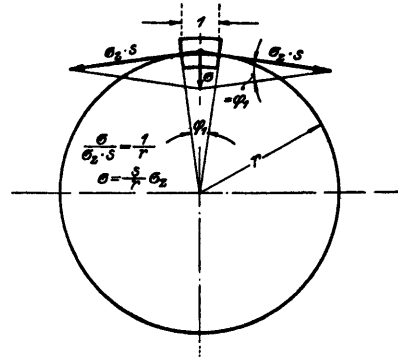
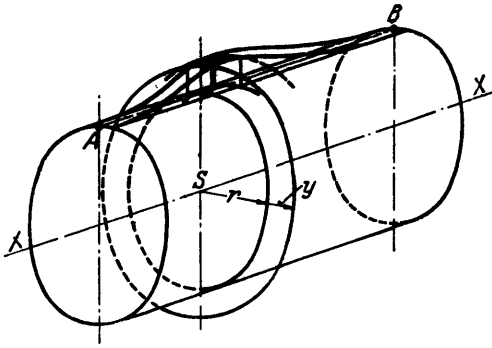

Figure 17 - The Interrelation Between Bending and Axial Elongation Figure 18 - Radial Resultant σ of the Tangential Forces $\sigma_z \times s$

which represents a combination of Equations [4.23] and [3.1].

The other equation of the class (c) expresses the fact that the mean value of the axial tensile stresses (parallel to the cylinder axis) taken over the shell thickness must disappear in the entire tube since, according to our assumption, the tube dealt with in this Section 4 is free to slide longitudinally (see Figure 13). Hence we write

$$C_1) \quad \sigma_z' = 0 \quad [4.31]$$

The accent mark in σ_z' is used to signify the fact that the corresponding vector is parallel to the x-axis, a designation which will be used everywhere in the following discussion.

At first it may seem unnecessary to write Equation [4.31] since it might be concluded from the analogy to the beam problem that it is not needed for the solution of this problem. Nevertheless, as the difference between the formulas [3.3] and [3.7] demonstrates for the tube of infinite length (Section 3), the stress σ_z' plays an important role for the following reasons:

Equation [4.30] shows a peculiar relationship between the static influence of two stresses or resultant stresses acting on plane elements perpendicular to each other. If this relationship is merely based on the specific geometrical form (cylindrical tube) of the two-dimensional structure here investigated, then there exists still another, much more pronounced interrelation of all stress systems which act in directions perpendicular to one another; this is due to the peculiar quality of all metals: the phenomenon of the so-called transverse contraction. As experience shows, it is often rather difficult to elicit understanding for this influence, so much so that even the most inevitable conclusions are doubted in all seriousness.

The introduction of m into these equations is regarded as a disguised reduction of E in order to bring about a better agreement with reality,

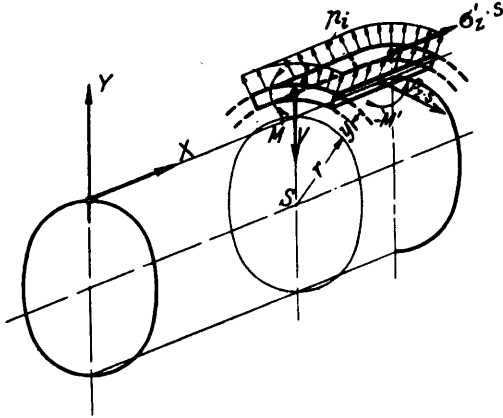

Figure 19 - Forces and Moments About the Element of Shell Plating

a result which it is claimed could be attained in a far less complicated manner without introducing m , etc. For this reason we shall discuss these things in detail here. For example, we know that a straight rod in simple tension undergoes an elongation (see Section 1)

$$(\Delta l)_1 = \epsilon_z l = \frac{\sigma_z}{E} l = \frac{Z l}{E F} \quad [4.32]$$

and at the same time a transverse contraction which, for instance, in the direction of the dimension d (Figure 20), is

and at the same time a transverse contraction which, for instance, in the direction of the dimension d (Figure 20), is

$$-(\Delta d)_1 = \frac{\epsilon_z}{m} d = \frac{\sigma_z}{m E} d = \frac{Z d}{m E F} \quad [4.33]$$

In this case the relations (see Figure 20)

$$\sigma_z = \frac{Z}{F} = E \epsilon_z, \quad \sigma_d = 0. \quad [4.34]$$

apply with respect to the normal stresses in the directions l and d .

It is clear, however, that the contraction by an amount $-\Delta d$ could also be effected in another way than by applying a tensile load Z , viz., by subjecting the rod to an external hydraulic pressure $-\sigma_d$ (Figure 20). The result would be

$$-(\Delta d)_2 = -\epsilon_d d = -\frac{\sigma_d}{E} d, \quad [4.35]$$

$$(\Delta l)_2 = -\frac{\epsilon_d}{m} l = -\frac{\sigma_d}{m E} l \quad [4.36]$$

Generally speaking, both of these influences are always present in a two-dimensional body; the total elongation Δl and the transverse contraction $-\Delta d$ in this general case must therefore be formed as the sum of $(\Delta l)_1$ and $(\Delta l)_2$ or $(\Delta d)_1$ and $(\Delta d)_2$, respectively, with the result that

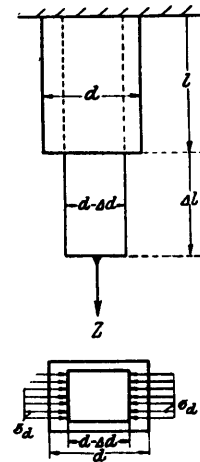

Figure 20 - Diagram of a Rod in Tension and Subject to an Additional Hydraulic Load σ_d

the longitudinal compression must be coupled with a transverse elongation so that finally the curved form seen in Figure 21 results. Only by the subsequent application of moments M' could the curvature ρ' be removed again.

After having made these comments, we shall now write down the following four equations of the class (c) in so far as they apply in our particular case (see Equation [4.2]):

$$A_1) \quad \sigma_z = \frac{m^2 E}{m^2 - 1} \left(\epsilon_z + \frac{\epsilon_z'}{m} \right) \quad [4.42]$$

$$A_2) \quad \sigma_z' = \frac{m^2 E}{m^2 - 1} \left(\epsilon_z' + \frac{\epsilon_z}{m} \right) \quad [4.43]$$

$$A_3) \quad M = -\frac{m^2 E}{m^2 - 1} \cdot \frac{s^3}{12} \left(\frac{1}{\rho} + \frac{1}{m \rho'} \right) \quad [4.44]$$

$$A_4) \quad M' = \frac{m^2 E}{m^2 - 1} \cdot \frac{s^3}{12} \left(\frac{1}{\rho'} + \frac{1}{m \rho} \right) \quad [4.45]$$

While the quantities σ_z , σ_z' , and M have already occurred in Equations [4.31] and [4.30], the quantity M' appears now for the first time. M' is a bending moment about the cylinder generatrix through the point in question. Even in the case of a tube there generally exists a second bending moment $M' = \frac{M}{m}$ about the longitudinal axis in addition to the bending moment M about a tangential axis. Under uniform hydrostatic pressure such a tube must always retain a circular cross section (where the change of curvature is zero) by virtue of symmetry. Only at several points where M disappears because, in addition to ρ' which vanishes everywhere, ρ is also equal to zero, i.e., at the inflection points M' disappears also.

Equations of class (b)

These relations resulting from differential geometry are now to be grouped together with specific reference to the case under discussion; the deflection y is here reckoned positive in the direction of p_1 , i.e., radially outwards.

$$\epsilon_z = \frac{y}{r} \quad [4.46]$$

$$B_{1-2}) \quad \epsilon_z' = \frac{d u}{d x} \quad [4.47]$$

$$\frac{1}{\rho} = \frac{d^2 y}{d x^2} \quad [4.48]$$

$$\frac{1}{\rho'} = 0 \quad [4.49]$$

Here the displacement u in the direction of the x -axis occurs for the first time; there arises the problem of determining by integration two unknown functions of x , viz., u and y . Therefore, it is actually a question of integrating two simultaneous differential equations for u and y . As a result, the elastic displacements in two directions perpendicular to each other are likewise closely related to one another as expected.

If we were to proceed now according to a purely schematic method introducing on one hand the Equations [4.48] and [4.49] into [4.44], the Equations [4.46] and [4.47] into [4.42], and to insert everything into [4.30], and if, on the other hand, the Equations [4.46] and [4.47] were introduced into [4.43] and the latter into [4.31], we would, indeed, obtain two equations both containing y and u and their differential quotients.

If we consider, however, that in Equation [4.30], formed in this manner, only the one term with ϵ_z' contains the displacement u and that ϵ_z' can be expressed in a simple manner in terms of ϵ_z , we succeed in setting up a single differential equation for y , viz., Equations [4.31] and [4.43] become

$$60) \quad 0 = \sigma_z' = \frac{m^2 E}{m^2 - 1} \left(\epsilon_z' + \frac{\epsilon_z}{m} \right) \quad [4.50]$$

hence

$$\epsilon_z' = -\frac{\epsilon_z}{m} \quad [4.51]$$

and inserted into Equation [4.42] we get

$$\sigma_z = \frac{m^2 E}{m^2 - 1} \epsilon_z \left(1 - \frac{1}{m^2} \right) = E \epsilon_z \quad [4.52]$$

or, from Equation [4.46]

$$60a) \quad \sigma_z = \frac{E y}{r} \quad [4.53]$$

Therewith Equation [4.30] becomes

$$\frac{d^2}{dx^2} \left(-\frac{m^2 E}{m^2 - 1} \cdot \frac{s^3}{12} \cdot \frac{d^2 y}{dx^2} \right) - \frac{E s}{r^2} y + p_i = 0 \quad [4.54]$$

or

$$II) \quad \frac{d^4 y}{dx^4} - 12 \left(\frac{p_i}{E s^3} - \frac{y}{r^2 s^2} \right) \frac{m^2 - 1}{m^2} = 0 \quad [4.55]$$

This is the differential equation of the elastic curve of an axially free, open cylindrical tube stiffened by frames and subject to a uniform internal pressure. It is entirely analogous to Equation [4.25] for a straight beam of rectangular section subjected to a uniform load, from which (while obviously being very similar) it differs in the following respects:

(a) From the pressure effects a deduction is made proportional to the deflection which, as we have seen, corresponds to that portion of the load which is absorbed directly, as it were, by the tangential tensions σ_z . This means, however, that in line with our previous statements a strip of the shell may be compared to a beam which is supported by an infinite number of elastic supports; hence, we are justified in speaking of the problem as being infinitely statically indeterminate.

(b) The factor $(m^2 - 1)$ expresses the total effect of the lateral contraction which seemed so confusing in the beginning.

Both serve to reduce the deflections y and hence the moments $-EJ : d^2 y/dx^2$; they tend therefore to relieve the strains in the shell. This is at once clear with respect to the modification discussed under (a); moreover, as far as the factor $(m^2 - 1)/m^2$ (which is equal to 0.91) is concerned, it implies that a deduction of 9 percent is to be made from the difference enclosed in parentheses. It is interesting and worthwhile to observe on the basis of Figure 21 the manner of lateral contraction of the beam when it reverts to its straight form (due to the application of appropriate moments M').

We shall add here a few historical remarks on Equation [4.55]. Both in the mathematical theory of elasticity (Enzyklopädie der mathematischen Wissenschaften, Vol. IV, Lamb) as well as in mechanical engineering (Stodola, Die Dampfturbine, 4th Edition, 1910, p. 96) and in civil engineering (see below) the equation appears (in even more general form) and it seems that the authors in question failed to realize its application in related fields of engineering; we regret that we were unable to determine the time and place of its first appearance. In shipbuilding it was probably F. Horn* who first established Equation [4.55] in connection with submarine construction by the Germaniawerft in Kiel and later at the Danzig Navy Yard. Like R. Lorenz (Z.V.D.I. 1910, p. 1397), however, apparently under the influence of Föppl (Cf. Vol. V), he failed to take into account the lateral contraction. While F. Horn had already drawn very far-reaching conclusions from his equations

*Not published; cf. Johow-Foerster, 4th Edition, Section 9.

which, however, were often misinterpreted and consequently questioned, Stodola recommended turning immediately to numerical values in each case instead of carrying out general calculations. The civil engineers Müller-Breslau, Poeschl and Terzaghi* and the mathematician Runge** probably came closer than anyone else to the very general solution (p varying linearly with x, variable wall-thickness, and the exclusion of Hooke's law). They developed methods of solution that produced quick results for wall-thicknesses varying stepwise (unsymmetric conditions of support). For shipbuilding, however, the symmetrical case has hitherto been the most important. The resumption of Horn's calculations for shipbuilding purposes is due to the initiative of Dr. Ing. Techel (Germaniawerft, Kiel) resulting from the critical supplement written by v. Sanden to the treatise of R. Lorenz (Problem der Parsons-Turbinentrommel). Dr. Techel continued to hope that the obscurities and uncertainties concerning the actual depth of immersion of submarines at rupture, which had existed for a long time, might be resolved by this method and that this might pave the way for the design of the most efficient construction of strength hulls in submarines. The results of calculations and experiments have now proven that Dr. Techel (whose hopes were not shared by anybody for a long time) was absolutely right; the use of the general theory of elasticity proved to be worthwhile beyond all expectations.

Let us now turn to the integration of Equation [4.55]. We write

$$\frac{d^4 y}{dx^4} + \frac{m^2 - 1}{m^2} \cdot \frac{12}{r^2 s^2} \left(y - \frac{r^2 p_i}{E s} \right) = 0 \quad [4.56]$$

and note that this equation possesses one solution

$$y = \frac{r^2 p_i}{E s} \quad [4.57]$$

which, according to Equation [3.3], represents the radial expansion of a frameless tube capable of free lengthwise contraction. Hence, we write (Figure 22)

$$\alpha) \quad \frac{r^2 p_i}{E s} = y_{\infty} \quad [4.58]$$

*Berechnung von Behältern nach neueren analytischen und graphischen Methoden, Berlin 1913, incl. numerous bibliographical references on the subject of civil engineering; application of the W. Ritz method.

**Über die Formänderung eines zylindrischen Wasserbehälters durch den Wasserdruck, Zeitschr. f. Math. u. Physik 1904, p. 254.

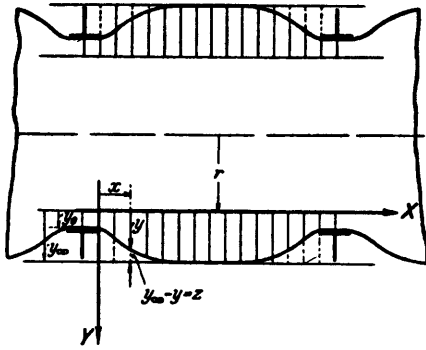

Figure 22 - Transversely Stiffened Tube under Internal Pressure

and furthermore, in order to reduce Equation [4.55] to its simplest possible form,

$$\beta) \quad \frac{m^2 - 1}{m^2} \cdot \frac{3}{r^2 s^2} = \alpha^4 \quad [4.59]$$

$$\gamma) \quad y_\infty - y = z \quad [4.60]$$

Thereby Equation [4.55] takes

the form

$$\text{II}') \quad \frac{d^4 z}{dx^4} + 4 \alpha^4 z = 0 \quad [4.61]$$

i.e., it becomes a homogeneous linear differential equation of the fourth order with constant coefficients. The solution of this equation is

$$z = e^{\lambda x} \quad [4.62]$$

since it follows that

$$\lambda^4 e^{\lambda x} + 4 \alpha^4 e^{\lambda x} = e^{\lambda x} (\lambda^4 + 4 \alpha^4) = 0 \quad [4.63]$$

This equation can be generally satisfied only if

$$\lambda^4 + 4 \alpha^4 = 0 \quad [4.64]$$

therefore

$$\lambda = \sqrt[4]{-4 \alpha^4} = \alpha \sqrt{2} \left[\pm \left(\frac{1}{2} \sqrt{2} \pm \frac{i}{2} \sqrt{2} \right) \right] = \pm (\alpha \pm \alpha i) \quad [4.65]$$

(see Hütte₂₂, I., p. 47)

The complete integral then reads (Hütte₂₂, I., p. 83)

$$z = e^{\alpha x} (\mathcal{A} \sin \alpha x + \mathcal{B} \cos \alpha x) + e^{-\alpha x} (\mathcal{C} \sin \alpha x + \mathcal{D} \cos \alpha x) \quad [4.66]$$

It is advisable to introduce here the hyperbolic functions (Hütte₂₂, I., p. 64; see also Engineering 1919, p. 306)

$$e^{\alpha x} = \mathcal{S}in \alpha x + \mathcal{C}of \alpha x; \quad e^{-\alpha x} = -\mathcal{S}in \alpha x + \mathcal{C}of \alpha x \quad [4.67]$$

in place of the exponential functions; as a result

$$z = (\mathcal{A} - \mathcal{C}) \mathcal{S}in \alpha x \sin \alpha x + (\mathcal{B} - \mathcal{D}) \mathcal{S}in \alpha x \cos \alpha x + (\mathcal{A} + \mathcal{C}) \mathcal{C}of \alpha x \sin \alpha x + (\mathcal{B} + \mathcal{D}) \mathcal{C}of \alpha x \cos \alpha x \quad [4.68]$$

for which we may also write

$$\text{II}_4') \quad z \equiv y_\infty - y = A' \sin \alpha x \sin \alpha x + B' \sin \alpha x \cos \alpha x + [4.69] \\ + C' \cos \alpha x \sin \alpha x + D' \cos \alpha x \cos \alpha x$$

since the constants are completely arbitrary.

We must calculate and insert α and y_∞ from the given data, according to Equations [4.59] and [4.60], as follows:

$$\alpha') \quad y_\infty \equiv \frac{r^2 p_i}{E s} \quad [4.70]$$

$$\beta') \quad \alpha \equiv \sqrt[4]{\frac{m^2 - 1}{m^2} \cdot \frac{3}{r^2 s^2}} = \frac{1.285}{\sqrt{r s}} \quad [4.71]$$

(The statement in the Z.V.D.I. 1910, p. 2062 to the effect that the factor $(m^2 - 1)/m^2$ is still to be added on the right side in Equation [4.70] is incorrect).

Arranged in a somewhat different order, it is easy to compare Equation [4.69] with the corresponding Equation [4.16].

$$\text{I}_{21}''') \quad E J \cdot y = p \frac{x^4}{24} + A \frac{x^3}{6} - M_A \frac{x^2}{2} + E J y_0' + E J y_0 \quad [4.72]$$

$$E s \cdot y = r^2 p_i + A'' \sin \alpha x \sin \alpha x + B'' \sin \alpha x \cos \alpha x + [4.73] \\ + C'' \cos \alpha x \sin \alpha x + D'' \cos \alpha x \cos \alpha x.$$

The essential difference is that in the upper equation the term with p is a function of x (and thus of the unsupported length l) while in the lower equation only the constant r^2 occurs as a factor. The influence of l is thus different. Moreover, in the case of the beam according to Equation [4.4] only the two constants A and M_A must be determined in order to calculate the moment curve. Here, according to Equations [4.44], [4.48], and [4.49], we must insert $d^2 y/dx^2$ into

$$M = -\frac{m^2 E}{m^2 - 1} \cdot \frac{s^3}{I_2} \cdot \frac{d^2 y}{dx^2} \quad [4.74]$$

in which obviously all four constants A'' , B'' , C'' , D'' must be determined. Finally, σ_z , σ_z' and M' must be calculated.

The boundary conditions which lead to determining A'' , B'' , C'' , D'' are similar to those mentioned previously:

$$\left. \begin{array}{l} \text{for } x = 0 \\ \text{for } x = l \end{array} \right\} \quad \text{we have (1) } y = y_0 \quad \text{and (2) } \frac{dy}{dx} = 0$$

Here y can no longer be assumed to be equal to zero as in the case of the beam since the frames in general are to be considered as elastic supports.

However, the boundary value y_0 or $y_\infty - y_0$ introduced here cannot be prescribed arbitrarily in terms of the present problem since it is definitely determined by the effect of the forces at the frame. We shall discuss this point in more detail later on; for the present let us point out that y_0 and hence z_0 are most correctly introduced as constants of integration. This is done in the following manner: The boundary condition (for $x = 0$ we have $y = y_0$ or $z = z_0$), if inserted in Equation [4.69], gives

$$\underline{z_0 = D'} \quad [4.75]$$

so that we may write

$$\text{II}_4''') \quad z = z_0 (A \sin \alpha x \sin \alpha x + B \sin \alpha x \cos \alpha x + C \cos \alpha x \sin \alpha x + \cos \alpha x \cos \alpha x) \quad [4.76]$$

If we now set up the three boundary conditions still to be satisfied

$$\text{for } x = 0 \quad \text{we have } \frac{dz}{dx} = 0$$

$$\text{for } x = l \quad \text{we have } \frac{dz}{dx} = 0 \text{ and } z = z_0$$

then we obtain with the aid of the relation

$$\frac{dz}{dx} = z_0 [(C - B) \sin \alpha x \sin \alpha x + (A + 1) \sin \alpha x \cos \alpha x + (A - 1) \cos \alpha x \sin \alpha x + (B + C) \cos \alpha x \cos \alpha x] \quad [4.77]$$

the following equations leading to the determination of A , B , and C :

$$0 = B + C \quad [4.78]$$

$$0 = (C - B) \sin \alpha l \sin \alpha l + (A + 1) \sin \alpha l \cos \alpha l + (A - 1) \cos \alpha l \sin \alpha l + (B + C) \cos \alpha l \cos \alpha l \quad [4.79]$$

$$1 = A \sin \alpha l \sin \alpha l + B \sin \alpha l \cos \alpha l + C \cos \alpha l \sin \alpha l + \cos \alpha l \cos \alpha l \quad [4.80]$$

Since according to the first of these equations $C = -B$, the last two equations result in

$$(\sin \alpha l \cos \alpha l + \cos \alpha l \sin \alpha l) A - 2 \sin \alpha l \sin \alpha l \cdot B + (\sin \alpha l \cos \alpha l - \cos \alpha l \sin \alpha l) = 0 \quad [4.81]$$

$$\sin \alpha l \sin \alpha l \cdot A + (\sin \alpha l \cos \alpha l - \cos \alpha l \sin \alpha l) B + \cos \alpha l \cos \alpha l = 1 \quad [4.82]$$

Solving these equations we get

$$A = - \frac{\sin \alpha l - \sin \alpha}{\sin \alpha l + \sin \alpha} \quad [4.83]$$

$$B = - \frac{\cos \alpha l - \cos \alpha}{\sin \alpha l + \sin \alpha} = - C \quad [4.84]$$

If these values are introduced into Equation [4.76] we obtain

$$\begin{aligned} -z &= \frac{z_0}{\sin \alpha l + \sin \alpha} [(\sin \alpha l - \sin \alpha) \sin \alpha x \sin \alpha x + \\ &\quad + (\cos \alpha l - \cos \alpha) \sin \alpha x \cos \alpha x - \\ &\quad - (\cos \alpha l - \cos \alpha) \cos \alpha x \sin \alpha x - \\ &\quad - (\sin \alpha l - \sin \alpha) \cos \alpha x \cos \alpha x] = \\ &= \frac{z_0}{\sin \alpha l + \sin \alpha} [\sin \alpha x (-\cos \alpha l \cos \alpha x - \sin \alpha l \sin \alpha x) + \\ &\quad + \cos \alpha x (-\sin \alpha l \cos \alpha x + \cos \alpha l \sin \alpha x) + \\ &\quad + \sin \alpha x (\sin \alpha l \sin \alpha x - \cos \alpha l \cos \alpha x) + \\ &\quad + \cos \alpha x (-\sin \alpha l \cos \alpha x + \cos \alpha l \sin \alpha x)]. \end{aligned} \quad [4.85]$$

Hence, if combined into terms with x and $l-x$ (Symmetry, see Equation [4.17]) and if y is inserted again, we obtain

$$\begin{aligned} y_\infty - y &= \frac{y_\infty - y_0}{\sin \alpha l + \sin \alpha} [\sin \alpha x \cos \alpha (l-x) + \cos \alpha x \sin \alpha (l-x) \\ &\quad + \sin \alpha x \cos \alpha (l-x) + \cos \alpha x \sin \alpha (l-x)] \quad [4.86] \\ \text{II}_{42}) \quad & \left(y_\infty \equiv \frac{r^2 p_i}{E s} \right) \end{aligned}$$

Now it only remains to determine the fourth constant of integration y_0 ; to this end we proceed by setting up the condition for the equilibrium of forces acting on the frame-ring.

The cut between "shell" and "frame" is made in such a way (see Figure 23) that a strip of the shell plating of the same width b as the flange of the frame is considered to form part of the frame while only the really unsupported part is considered as "shell"; generally other subdivisions are also conceivable. However, it has always been found that in this way the results of the calculation agree best with experience and hence we expect to apply this method everywhere hereafter. Moreover, this method of separation has, in itself, no artificial character especially when the stiffening elements lie on the side of the shell opposite to the pressure side, as is usually the case (that means outside frames in case of internal pressure and inside frames in case of external pressure).

F. Horn has determined y_0 in a different manner; he starts out on

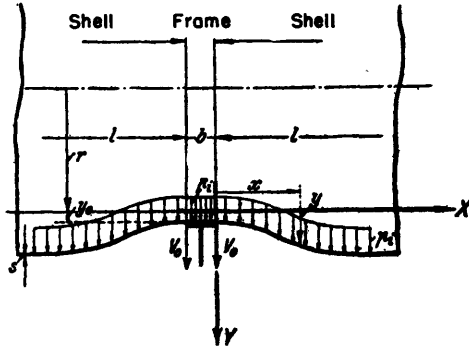

Figure 23 - Effects of Forces at the Frame

the assumption that the sum of the tangential forces which act in a longitudinal section and which vary from point to point must be equal to the total hydrostatic pressure $r(l + b) p_1$ (see Figure 23) exerted on the corresponding section, of which an initially unknown portion is absorbed by the frame section. Horn determines this section and in this way he also arrives at the results set forth in the following discussion.

In accordance with Equation [2.4]* the following equation applies for the frame-ring as defined above

$$\epsilon) \quad y_0 = \frac{r^2 p_1}{E(F + bs)} \quad [4.87]$$

Here p_1 is now to be replaced by the sum of the external forces, viz., first, the hydraulic pressure acting on the frame width b (per 1 cm of the circumference of the flange, thus $b p_1$), and second, the two shear forces $V_{0 \text{ right}} = V_{0 \text{ left}} = V_0$ transmitted to the frame by each of the shells adjoining on both sides.

$$\begin{aligned} 2V_0 &= 2 \left(\frac{dM}{dx} \right)_0 = -2 \frac{m^2 E}{m^2 - 1} \cdot \frac{s^3}{12} \left(\frac{d^3 y}{dx^3} \right)_{x=0} = \\ &= + \frac{2 m^2 E}{m^2 - 1} \cdot \frac{s^3}{12} \cdot 4 \alpha^3 \frac{\cos \alpha l - \cos \alpha l}{\sin \alpha l + \sin \alpha l} (y_\infty - y_0). \end{aligned} \quad [4.88]$$

Hence, Equation [4.87] becomes

$$\epsilon') \quad y_0 = \frac{r^2}{E(F + bs)} \left[b p_1 + \frac{2}{3} \cdot \frac{m^2 E}{m^2 - 1} s^3 \alpha^3 \times \right. \\ \left. \times \frac{\cos \alpha l - \cos \alpha l}{\sin \alpha l + \sin \alpha l} (y_\infty - y_0) \right] \quad [4.89]$$

For reasons of simplicity, the reduction of p_1 and V_0 to the neutral circle ($R = r_n$) of the frame profile (in the ratio of r/r_n), which is made occasionally, will not be introduced into our formulas. In the case of frames having depths that are large compared to r it may be in order and it can always be carried out without any fundamental difficulties.

*In the following, F always denotes the cross section of the actual frame, i.e., of the frame angle alone; $F + bs$, then, is the total sectional area of the frame as explained above.

Equation [4.89] in which only the fourth constant of integration y_0 occurs besides the magnitudes which are given, we must still solve for y_0 , or, according to the difference required in Equation [4.86], for $y_\infty - y_0$, respectively. We write

$$\epsilon''') \quad y_0 - \frac{2}{3} \cdot \frac{m^2}{m^2 - 1} \cdot \frac{s^3 r^2 \alpha^3}{F + b s} \cdot \frac{\text{Cof } \alpha l - \cos \alpha l}{\text{Sin } \alpha l + \sin \alpha l} (y_\infty - y_0) - \frac{r^2 b p_i}{E(F + b s)} = 0 \quad [4.90]$$

This becomes

$$\begin{aligned} \frac{m^2}{m^2 - 1} s^3 r^2 \alpha^3 &= \frac{m^2}{m^2 - 1} s^3 r^2 \sqrt[4]{\left(\frac{m^2 - 1}{m^2}\right)^3 \cdot \frac{27}{(r^2 s^2)^3}} \\ &= \sqrt[4]{\frac{27 m^2}{m^2 - 1}} s^6 r^2 = \sqrt[4]{\frac{27 m^2}{m^2 - 1}} \sqrt{s^3 r}. \end{aligned} \quad [4.91]$$

For brevity, we write

$$\begin{aligned} \eta) \quad \beta &\equiv \frac{2}{3} \sqrt[4]{\frac{27 m^2}{m^2 - 1}} \cdot \frac{\text{Cof } \alpha l - \cos \alpha l}{\text{Sin } \alpha l + \sin \alpha l} \cdot \frac{\sqrt{s^3 r}}{F + b s} = \\ &= 1.555 \cdot \frac{\text{Cof } \alpha l - \cos \alpha l}{\text{Sin } \alpha l + \sin \alpha l} \cdot \frac{\sqrt{s^3 r}}{F + b s} = 1.555 N \frac{t \sqrt{t D/2}}{A + b t} \end{aligned} \quad [4.92]$$

and obtain from Equation [4.90]

$$(y_\infty - y_0) + \beta (y_\infty - y_0) + \frac{r^2 b p_i}{E(F + b s)} y_\infty = 0, \quad [4.93]$$

hence, after partial insertion of y_∞

$$y_\infty - y_0 = \frac{1}{1 + \beta} \cdot \frac{r^2 p_i}{E s} \left(1 - \frac{b s}{F + b s}\right) \quad [4.94]$$

or

$$\epsilon''') \quad y_\infty - y_0 = \frac{F}{F + b s} \cdot \frac{r^2}{E s} \cdot \frac{p_i}{1 + \beta} \quad [4.95]$$

Finally the equation of the elastic curve becomes

$$\begin{aligned} y_\infty - y &= \frac{r^2 p_i}{E s} \cdot \frac{F/(F + b s)}{(1 + \beta)(\text{Sin } \alpha l + \sin \alpha l)} \times \\ &\times [\text{Sin } \alpha x \cos \alpha (1 - x) + \text{Cof } \alpha x \sin \alpha (1 - x) + \\ &+ \sin \alpha x \text{Cof } \alpha (1 - x) + \cos \alpha x \text{Sin } \alpha (1 - x)] \end{aligned} \quad [4.96]$$

or solved for y

$$64) \quad y = \frac{r^2 p_i}{E s} \left[1 - \frac{F}{F + b s} \times \frac{\sin \alpha x \cos \alpha (1-x) + \dots + \dots + \cos \alpha x \sin \alpha (1-x)}{(1 + \beta)(\sin \alpha l + \sin \alpha l)} \right] \quad [4.97]$$

Now all stresses can be written (see Equations [4.50] and [4.44])

1. The axial tensile stress

$$60) \quad \sigma_z' = 0 \quad (\text{at all points } x \text{ of shell}) \quad [4.98]$$

2. The tangential tensile stress

(a) at any point x

$$60a) \quad \sigma_z = \frac{E y}{r} = \frac{r p_i}{s} \left\{ 1 - \frac{F/(F + b s)}{(1 + \beta)(\sin \alpha l + \sin \alpha l)} \times [\sin \alpha x \cos \alpha (1-x) + \dots + \dots + \cos \alpha x \sin \alpha (1-x)] \right\} \quad [4.99]$$

(b) the maximum value (for $x = l/2$)

$$60'a) \quad \sigma_{z \max} = (\sigma_z)_{x=l/2} = \frac{r p_i}{s} \left\{ 1 - \frac{2F}{F + b s} \times \frac{\sin \frac{\alpha l}{2} \cos \frac{\alpha l}{2} + \cos \frac{\alpha l}{2} \sin \frac{\alpha l}{2}}{(1 + \beta)(\sin \alpha l + \sin \alpha l)} \right\} \quad [4.100]$$

3. The axial bending stress (tangential moment-axis)

(a) at any point x

$$\begin{aligned} \sigma_b &= \frac{|M|}{s^2/6} = \frac{m^2 E}{m^2 - 1} \cdot \frac{s}{2} \cdot \frac{d^2 y}{d x^2} = \\ &= \frac{m^2 E}{m^2 - 1} \cdot \frac{s}{2} \cdot 2 \alpha^2 \frac{y_\infty - y_0}{\sin \alpha l + \sin \alpha l} \times \\ &\quad \times [\cos \alpha x \sin \alpha (1-x) - \sin \alpha x \cos \alpha (1-x) - \\ &\quad - \cos \alpha x \sin \alpha (1-x) + \sin \alpha x \cos \alpha (1-x)] \end{aligned} \quad [4.101]$$

$$\begin{aligned} &= \sqrt{\frac{3 m^2}{m^2 - 1}} \cdot \frac{E}{r} \cdot \frac{F}{F + b s} \cdot \frac{r^2}{E s} \cdot \frac{p_i}{1 + \beta} \times \\ &\quad \times \frac{\cos \alpha x \sin \alpha (1-x) - \dots - \dots + \sin \alpha x \cos \alpha (1-x)}{\sin \alpha l + \sin \alpha l} \\ &= \frac{r p_i}{s} \cdot \frac{1.815 F}{F + b s} \times \\ &\quad \times \frac{\cos \alpha x \sin \alpha (1-x) - \dots - \dots + \sin \alpha x \cos \alpha (1-x)}{(1 + \beta)(\sin \alpha l + \sin \alpha l)} \end{aligned} \quad [4.102]$$

(b) the maximum value (for $x = 0$ and $x = l$)

$$60'b) \quad \sigma_{b \max} = (\sigma_b)_{x=0} = \frac{r p_i}{s} \cdot \frac{1.815 F}{F + b s} \cdot \frac{\sin \alpha l - \sin \alpha l}{(1 + \beta)(\sin \alpha l + \sin \alpha l)} \quad [4.103]$$

4. The tangential bending stress (longitudinal moment-axis)
 (a) at any point x

$$60c) \quad \sigma_b' = \frac{|M'|}{s^2/6} = \frac{\sigma_b}{m} \quad [4.104]$$

(b) for $x = l/2$

$$60'c) \quad (\sigma_b')_{x=l/2} = \frac{r P_i}{s} \cdot 0.545 \cdot \frac{2F}{F + bs} \cdot \frac{\sin \frac{\alpha l}{2} \cos \frac{\alpha l}{2} - \cos \frac{\alpha l}{2} \sin \frac{\alpha l}{2}}{(1 + \beta)(\sin \alpha l + \sin \alpha l)} \quad [4.105]$$

in all of the above formulas

$$\eta) \quad \beta \equiv 1.555 \frac{\sqrt{s^3 r}}{F} \cdot \frac{\cos \alpha l - \cos \alpha l}{\sin \alpha l + \sin \alpha l} \quad [4.106]$$

and

$$\beta') \quad \alpha \equiv \frac{1.285}{\sqrt{rs}} \quad [4.107]$$

In the vast majority of cases $\sigma_b \max$ has proved to be the greatest stress, but for important investigations it is best to plot both σ_b (longitudinal stress) and $\sigma_z + \sigma_b'$ (transverse stress) as functions of x. We might then continue and, after calculating the shear stresses from the shear forces $V = dM/dx$, determine and plot the axes of principal elongation and the corresponding principal elongations (or "ideal principal stresses" Hütte²² I., p. 527).* It was found, however, that our calculations agree quite satisfactorily with experience if one regards as destructive pressure that pressure at which either σ_b or $\sigma_z + \sigma_b'$ (or both expressions at the same time) reach the yield point (occurrence of major permanent deformations). This may be done even though here, as in the case of the beam bending, E was regarded as constant in the entire calculation which presupposes that, strictly speaking, the limit of proportionality is not exceeded at any point of the shell. If

*After the publication of this paper, there appeared an article by B.P. Haigh (Engineering 1920, p. 158), in which the author used a procedure analogous to Huber's method ("Drang und Zwang," p. 50) where the elastic limit is introduced. Haigh extended the concept of the "limiting strain energy" and found it to be more logical than the usual hypotheses used up to this time for finding the point in a loaded body where permanent deformation occurs for the first time, and also for the determination of the limit load in the case of polyaxial stress conditions. A numerical check of the quantity of experimental data at our disposal has not been possible thus far.

the shell is almost exactly of uniform thickness, there occur in a number of cases no major deformations, even beyond the elastic limit. This is in agreement with our statements on the beam problem, so that a certain degree of safety would still be included in the conditions

$$62) \quad \sigma_{b \max} < \sigma_{fz} \quad [4.108]$$

$$62a) \quad \sigma_{z \max} + \sigma_{b'1/2} < \sigma_{fz} \quad [4.109]$$

which is not taken into account in the following discussion. Equations [4.108] and [4.109] together with Equations [4.100], [4.103], and [4.105] thus represent the necessary and sufficient conditions for the absence of substantial permanent deformations under internal pressure.

In August 1917, the formulas [4.98] to [4.105] were used by the Germaniawerft in cases where b_s was small relative to F ($b = 0$). At the suggestion of Dipl. Ing. Schulze, they were also used for the case $b \neq 0$ in March 1918.

The sinh-cosh-sin-cos-functions occurring in these formulae can be determined according to the tables in "Hütte" or, for more exact calculations, according to Burrau (Berlin, Reimer 1907): the use of the graphs given in the second part is the most convenient. The latter reference points out in detail the peculiar nature of the functions which asymptotically approach limiting values above certain values of αl . Here we shall only discuss a few limiting cases.

1. If the frame is absolutely yielding, we must write

$$F = 0 \quad \text{hence} \quad \beta = \infty \quad [4.110]$$

therefore

$$60a''=40) \quad \sigma_{z \max} = \frac{r}{s} p_i \quad [4.111]$$

i.e., we again obtain Equation [3.1] for the tube of infinite length; at the same time, $\sigma_b = 0$, as must evidently be the case.

2. If the value of F is finite and αl is greater than $2 \frac{1}{2} \pi$, i.e.,

$$l > 6.11 \sqrt{r s} \quad [4.112]$$

then $\sigma_{z \max}$ is practically independent of the "frame spacing" because the fraction with the hyperbolic and trigonometric functions in Equation [4.100]

becomes zero, and we again have the value

$$\sigma_{z \max} = \frac{r}{s} p_i \quad [4.113]$$

3. Also, by increasing l , σ_b will finally become independent of l , in fact it is practically so for $\alpha l = 3/2 \pi$, i.e., for

$$l > 3.67 \sqrt{r's} \quad [4.114]$$

because the fractions with the hyperbolic and trigonometric functions become practically equal to unity, both in Equation [4.103] and in Equation [4.106]. In that case we have

$$\eta') \quad \beta = 1.555 \frac{\sqrt{s^3 r}}{F + b s} \quad [4.115]$$

and

$$60b'') \quad \sigma_{b \max} = \frac{r p_i}{s} \cdot \frac{1.815 F}{F + b s + 1.555 \sqrt{s^3 r}} \quad [4.116]$$

If, moreover, the transverse stiffening is completely rigid as is practically the case with bulkheads, then $F = \infty$, and we obtain

$$60''b) \quad \sigma_{b \max} = 1.815 \frac{r p_i}{s} \quad [4.117]$$

This is 81.5 percent greater than the simple tangential stress according to Equation [3.1] which for a long time was considered as critical, since a more exact calculation was unknown. It is easy to see that under otherwise equal conditions σ_b becomes the greater, the less the frames yield. Experience confirms this inasmuch as in the case of frames of varying elasticity the first damage of the shell usually occurs near the most inelastic supports, viz., at the bulkheads. The reason that the critical stresses become independent of the frame spacing as the latter increases is found in the fact that bending occurs only near the frames, in the regions a-b and c-d (Figure 24) while the intervening part b-c of the tube remains straight and is uniformly elongated in radial direction only, just as if it were a section of an unstiffened tube.

It follows that the shell will obtain material relief from the frames only when these are spaced fairly close together and are not too strongly constructed. Horn and Lorenz have thoroughly investigated this

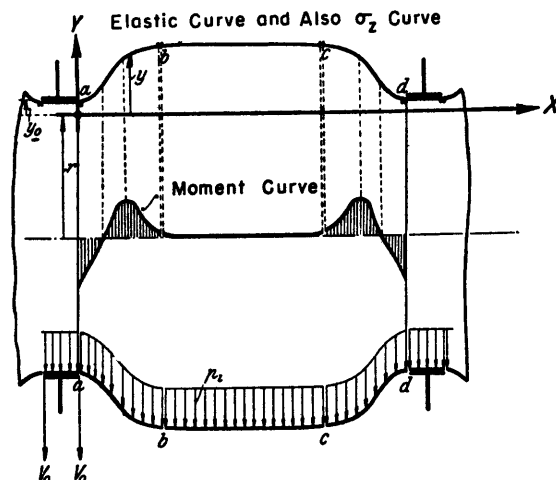

Figure 24 - Fundamental Variation of the Deflection Curve and of the Moment Curve

peculiar influence of l and utilized it for the suitable arrangement and dimensioning of the frames. For further details see Part II.

The conclusion drawn occasionally that above $\alpha l = \pi$ the frame spacing has no influence upon the safety of the entire structure is correct to a limited extent only. In like manner, rough estimates which consider a, b, c, d as a beam fixed at both ends lead, in many cases, to entirely erroneous conclusions, as will be seen by a glance at the moment curve (Figure 24).

If it is of interest to know the axial displacement u (at the point x), the latter (see the above developments from Equation [4.46] to Equation [4.98]) can be obtained from

$$\frac{d u}{d x} \equiv \varepsilon'_z = -\frac{\varepsilon_z}{m} - \frac{\varepsilon z}{m} = -\frac{y}{m r} \quad [4.118]$$

from which it follows that

$$65) \quad u = \frac{-1}{m r} \int_0^x y \, d x \quad [4.119]$$

Here y is to be substituted from Equation (4.97) and the integration (which will not be discussed any further here) is to be performed. The total elastic mutual approach of two adjacent frames separated by the free length l of shell plating is

$$\Delta l = \frac{1}{m r} \int_0^l y \, d x \quad [4.120]$$

In experiments and observations Δl can be used in an especially convenient manner for the purpose of checking the theory.

b. UNIFORM EXTERNAL PRESSURE p_a

Preliminary Remarks

The stress calculation originally set up for internal pressure which led to Equation [4.55] is directly applicable to the case of external pressures because negative values of p_1 , i.e., external pressures, correspond to negative values of y (see Equation [4.55]). This means that the elastic curve for a given external pressure is the reverse of that elastic curve which corresponds to an equal hydrostatic internal pressure. Of course, compressive stresses substitute for tensile stresses, etc.

Euler's formula for collapse of an initially straight pin-end rod (Equation [1.15]), Föppl's formula for the circular ring (Equation [2.7]) and Bresse's formula for the infinitely long, thin-walled cylindrical tube correspond to the figures of equilibrium drawn schematically in Figures 6 and 9. Besides these figures determinative for judging safety, there are still an infinite number of others which are characterized by a greater number of undulations of the elastic curve than indicated in Figures 25 and 26.

The corresponding values of the critical loads for an integral number of waves are

$$16'' \quad D_k = \nu^2 \pi E J = \nu^2 \pi E \frac{s^3}{12} \quad (s < 1) \quad [4.121]$$

$$36'' \quad p_k = \frac{n^2 - 1}{r^3} E J = \frac{n^2 - 1}{12} E \left(\frac{s}{r}\right)^3 \quad [4.122]$$

and

$$56'' \quad p_k = \frac{n^2 - 1}{12} \frac{m^2 E}{m^2 - 1} \left(\frac{s}{r}\right)^3 \quad [4.123]$$

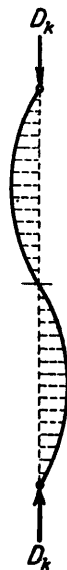

Figure 25 - Straight Rod,
Case of Collapse $\nu=2$
(Two Half Waves)

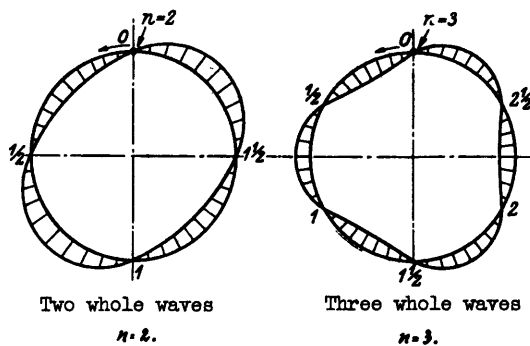

Figure 26 - Mode of Collapse in the
Case of the Circular Ring

These formulas show that, in general, the critical loads increase rapidly with the wave number as the square of ν and approximately as the square of n . The nonexistence of the practical possibility of "skipping" the lower critical loads—similar perhaps to the rapid passing through of critical speeds of rotation which occurs in the case of rotating shafts—explains why the critical loads corresponding to higher wave numbers must be disregarded in judging safety. They represent merely an interesting theoretical possibility and are extremely unstable. The situation is entirely different with respect to the problem to be discussed now where in general the lowest critical pressures no longer correspond to the smallest number of waves, as will be seen presently.

In analogy to the straight compressed rod, the circular ring, and the infinitely long unstiffened cylindrical tube under external pressure, the two conditions which are obtained by reversing Equations [4.108] and [4.109] so as to fit external pressures, and by making use of Equations [4.100], [4.103], and [4.105]

$$72) \quad P_a < \frac{\frac{s}{r} \sigma_{fd}}{\frac{1.815 F}{F + b s} (1 + \beta) (\sin \alpha l + \sin \alpha l)} \quad [4.124]$$

and

$$72a) \quad P_a < \frac{\frac{r}{s} \sigma_{fd}}{1 - \frac{2F}{F + b s} \cdot \frac{0.455 \sin \frac{\alpha l}{2} \cos \frac{\alpha l}{2} + 1.545 \cosh \frac{\alpha l}{2} \sin \frac{\alpha l}{2}} (1 + \beta) (\sin \alpha l + \sin \alpha l)} \quad [4.125]^*$$

Translator's Note:

*Hovgaard (Memorandum No 88, opp. p. 37) adds the following annotation to this: Equation [4.125] should read

$$P_a < \frac{\frac{s}{r} \sigma_{fd}}{1 - \frac{2F}{F + b s} \frac{1.545 \sinh \frac{\alpha l}{2} \cos \frac{\alpha l}{2} + 0.455 \cosh \frac{\alpha l}{2} \sin \frac{\alpha l}{2}} (1 + \beta) (\sinh \alpha l + \sin \alpha l)}$$

since the bending stress is a maximum tension or compression at either the outside or inside surface of the plate, $\sigma'_{b \max}$ should be in the direction to increase the hoop stress ($\sigma_{d \max}$) on one side of the plate and decrease it on the other. Which side is increased or decreased makes no difference. The maximum stress will result when and where these two stresses are in the same direction.

The $\cosh \frac{\alpha l}{2} \sin \frac{\alpha l}{2}$ term is always larger than $\sinh \frac{\alpha l}{2} \cos \frac{\alpha l}{2}$ and should, therefore, be multiplied by the smaller term 0.455 to make the total stress a maximum.

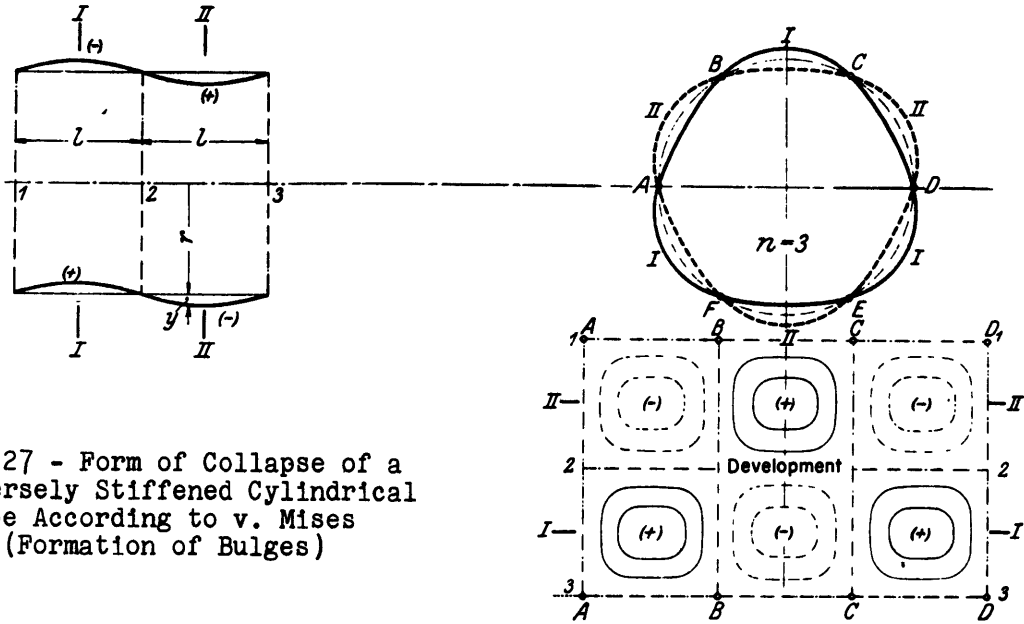

Figure 27 - Form of Collapse of a Transversely Stiffened Cylindrical Tube According to v. Mises (Formation of Bulges)

are necessary to prevent considerable permanent strains. They are no longer sufficient, however, since generally other figures of equilibrium are possible (see Figure 27), viz., when $p_a \geq p_k$ (see v. Mises, Z.V.D.I., 1914, p. 750), where

$$\begin{aligned}
 p_k = & \frac{E}{\left[1 + \left(\frac{n-1}{\pi \cdot \frac{l}{r}} \right)^2 \right]^2} \cdot \frac{s}{r} + \\
 76) & + \frac{1}{12} \left\{ (n^2 - 1) + \frac{2n^2 - \frac{m+1}{m}}{1 + \left(\frac{n-1}{\pi \cdot \frac{l}{r}} \right)^2} \right\} \frac{m^2 E}{m^2 - 1} \left(\frac{s}{r} \right)^3
 \end{aligned} \tag{4.126}$$

In this formula which represents the final result of the collapse calculation and which, for $l = \infty$, is transformed into Equation [4.123], n , i.e., the number of bulges on the circumference resulting from collapse, is obviously no longer indicated once for all in such a manner that it corresponds to the critical (i.e., the lowest) value of p_k . As the construction of the formula indicates, both for $n = 1$ and for $n = \infty$ we have $p_k = \infty$, whereas intermediate values of n give finite pressures. There will always be one very definite n_{\min} depending on the ratios s/r and l/r which correspond to the smallest $p_k = p_{k \min}$ (in special cases two values adjacent to each other). In order to determine n_{\min} , tables and diagrams have been constructed (see Part II); forms of collapse with twenty bulges, occasionally as many as forty, occur

frequently in strength hulls of submarines.*

If, as a result of the discussion regarding Equation [3.10], the bases of calculation from which Equation [4.126] is derived are examined, it will be found that the conditions along the edges ($x = 0$ and $x = 1$) are not entirely free from certain artificialities which must become obvious when compared with the stress calculations. It is true that at these points the radial elastic displacement y vanishes, but not the axial and tangential displacement, so that a sliding of the shell on the frame in axial and tangential directions (or yielding of the frame in these directions without resistance) should be possible. Furthermore, the tangent to the elastic curve is not horizontal ($dy/dx \neq 0$) as shown in Figure 27, whereas σ_d' , on the other hand, disappears so that we are fully justified in speaking of complete elasticity of the tube.

In spite of this, however, Equation [4.126] proved to be exceptionally valuable in one respect: in all cases it correctly indicated the number of bulges on the circumference, or in the case of isolated bulges, the calculated length of the bulges

$$\lambda = \frac{2 \pi r}{n_{\min}} \quad [4.127]$$

This was the case even when the experimental bodies were geometrically of anything but ideal shape (circular form, plate thickness, etc.). In view of what was said previously about the degree of safety against buckling in connection with practical experiments, it is not surprising that, on the whole, the corresponding critical pressure was not nearly attained. The functional character of the relationship of $p_{k \min}$ and s/r and l/r was likewise correct provided, however, that the conditions underlying the stress calculation (Equations [4.124] and [4.125]) were taken into account. This leads to the most difficult part of the investigations, viz., the question: What happens when the elastic limit is exceeded at certain points of the shell plating?

*An approximate form of Equation [4.126] has been derived with elementary means by Gumbel (Schiffbau 1918, p. 225); the latter starts out with a deformation condition which in the axial section corresponds to the relation

$$y = y_{\max} \sin^2 \frac{\pi x}{l} \quad (\text{square of a sine curve})$$

whereas v. Mises, on the basis of the general elasticity equations, arrives at the linear sine curve of the bulges as shown in Figure 27.

We define the quotient

$$77) \quad S_M = \frac{P_{k \min}}{P_a} \quad [4.128]$$

as the "Mises' factor of safety," i.e., the safety of the plate against buckling, and we shall assume in the following purely fundamental conditions that $S_M = 1$. The consideration of the lower external pressures in portions of $p_{k \min}$ which are actually attainable on the basis of experience is a matter to be taken up in the second part just as the solution of the problem of the most suitable construction of a strength hull, viz., a strength hull of uniform strength which, with a given diameter and a given "depth of immersion," has the least iron weight; this result is to be achieved by going to the very limit with all safeties and stresses in a uniform manner, or better yet, in a manner slightly varying in accordance with the "vital importance of the organs."

Here in Part I we deal with the investigation of the strength of a given pressure hull. Besides, ways and means are pointed out which lead to the determination of its weakest point determinative of the "collapse depth" (maximum depth of immersion) which enables us to determine the collapse depth itself.

The following cases are to be distinguished:

1. Collapse determinative: Widely-spaced frames.
2. Stress determinative:
 - (a) Spacing of frames l without any sensible influence on σ_b , ($\sigma_b' = \sigma_b/m$) and σ_d : normally-spaced frames;
 - (b) Spacing of frames l of decided influence on σ_b , ($\sigma_b' = \sigma_b/m$) and σ_d : closely-spaced frames.

While Equation [4.126] applies in case 1 and Equations [4.124] and [4.125] apply in case 2(b), the corresponding equations for 2(a) are

$$72') \quad P_a < \frac{F + bs + 1.555 \sqrt{s^3 r}}{1.815 F} \cdot \frac{s}{r} \sigma_{fd} \quad [4.129]$$

$$72a') \quad P_a < \frac{s}{r} \sigma_{fd} \quad [4.130]$$

As pointed out previously, the Equations [4.124], [4.129] very often impose more severe conditions than Equations [4.125], [4.130].

The boundaries between the three regions cannot in general be sharply defined; they depend on whether $\sigma_b \max$ or $\sigma_d \max + \sigma_b^{1/2}$ are

determinative, and they depend furthermore on the degree to which the frames yield, i.e., on the value of F . The boundary between cases 2(a) and 2(b) as explained at the end of Section 4 is found to be about $l = (2.4 \text{ to } 6.1)\sqrt{rs}$, while the value $l = 670\sqrt{s^3/r}$ adopted for submarines may serve as a first approximation to the boundary between 1 and 2 (l, r, s in cm). We note here that there are cases where the region 1 goes directly over in region 2(b) where, in other words, region 2(a) shrinks to nothing. Here again, the reader's attention is called to Part II.

At this point we have to examine the conditions when σ_b or $\sigma_d + \sigma_b'$ exceed the elastic limit (when, therefore—and this is in itself permissible— p is greater than the values obtained from Equations [4.124], [4.125] or [4.129], [4.130] after substituting σ_{pd} for σ_{fd}) and when, at the same time, p_a is still smaller than p_k (according to Equation [4.126]). The shell plating is then in a condition similar to that of the "semi-slender rod" or the "semi-heavy ring" subjected to a full load since the value of the modulus of elasticity substituted in [4.126] cannot then be correct. Hence, Equation [4.126], a formula for collapse, in which E plays a very important role, would yield too high values for p_k . We have seen before how v. Kármán coped with this difficulty in the case of the straight rod under compression and we have applied his method to the case of the circular ring under external pressure. The same thing might be done without difficulty in the case of the unstiffened cylindrical tube of infinite length. If the attempt is made, however, to apply it to the tube stiffened by frames a distance l apart, new difficulties are encountered. In the former cases the same compressive stress always existed at all points of the body prior to collapse and as a result with increasing pressure D , p_a , or p_a all particles were simultaneously at the same point of the stress-strain curve as long as the critical pressure D_k , p_k , or p_k was not yet reached. Thus, it was possible and relatively easy to substitute for E an improved modulus M (dependent upon D , p_a , etc.) in the collapse formulas of Euler, Föppl, etc., as v. Kármán did.* But if, in the present case, one does not wish to devise a particularly artificial arrangement of the frames such that the frames are at first set into the tube "with a clearance" and that this clearance is gaged in such a way that precisely

*v. Kármán finds M as a function of σ_d by equating

$$\Delta\sigma = \left(\frac{d\sigma}{d\varepsilon}\right)_{\sigma=\sigma_d} \Delta\varepsilon$$

(see Figure 5) where $\frac{d\sigma}{d\varepsilon}$ possesses different values according to whether it is taken at the point with the stress $\sigma + \Delta\sigma$ (internal edge fibre F_1) or $\sigma - \Delta\sigma$ (external fibre F). [Translator's note: The subscripts 1 and a stand for "innen" (internal) and "ausen" (external)].

for $p_a = p_k$ the shell would rest upon the frames, then the shell is found to be in a more complicated state of stress which, as we have seen, is characterized not only by the compressive stress σ_d , but also by the bending stresses σ_b and σ_b' . All these stresses are functions of x . The elastic limit is not, therefore, exceeded nor the modulus of elasticity reduced simultaneously in all particles of the material when the depth of immersion increases; instead, this effect is at first limited to those supporting edges or circular lines on the surface of the shell where σ_b and $\sigma_d + \sigma_b'$ have the highest values. By further increasing the external pressure, the excess strains are gradually extended to the inner parts of the plating and over the surface of the shell as indicated in Figure 28.

The modulus of elasticity is, therefore, even before collapse takes place, a function of x and the distance η from the neutral "surface" (see Figure 28) as determined from the stress calculations.

It is very important to realize this fact even though we may hardly think of introducing such a variability into the calculations of v . Mises. Experiments have shown that in the case of certain dimensions of the tubes and stiffenings (closely-spaced frames) absolutely pure "contraction" (i.e., a uniform inward bulging between each set of frames*) without wave formation occurs (y according to Equation [4.97]), whereas in the case of certain other dimensions (widely-spaced frames) an absolutely pure wave formation without contraction takes place. It is, therefore, to be expected that at certain intermediate frame spacings both phenomena will occur simultaneously due to imperfections in workmanship.

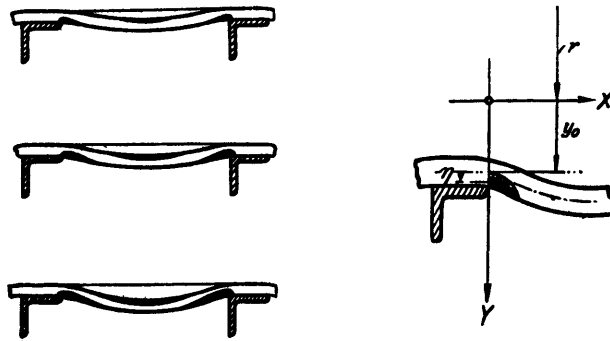

Figure 28 - Schematic View of the Gradual Extension of the Regions Where the Elastic Limit Is Exceeded as the Pressure Increases

*Hovgaard, Memorandum No. 88, p. 41.

In these cases collapse by instability and breakdown by flow of the material merge into each other.

In actual practice the situation is such that in these cases theory cannot as yet determine the exact course of the transitions which correspond to the curves a-c in Figures 7 and 9a. Probably it will at first be best to draw in the course corresponding to the curve sections a-b-c as previously given and then, starting from point c, to draw the transition curve by judgment, similar to that in Figures 7 and 9a. The principal difficulty lies in the fact that the position of point a cannot be determined by calculation. In special cases, however, such as that indicated in Figure 24 in which by far the major part of the shell is subjected to stress similar to that existing in a section of an infinitely long tube ($\sigma_d = rp_a/s$, $\sigma_b = \sigma_b' = 0$), only a small error is committed by simply assuming $\sigma_d \max$ is critical for the entire shell and calculating M accordingly. Yet, on reducing the frame spacing this error will become greater and greater; in this connection it is important to observe, however, that the true transition curves must always lie between the broken curve a-b-c and that curve a-c which results when the maximum stress that occurs is assumed to exist in the entire shell and when the corresponding v. Kármán modulus M is applied. The possible error is thus kept within rather narrow limits. This point is dealt with further in Part II.

5. CYLINDRICAL TUBE STIFFENED BY TRANSVERSE FRAMES AND LOADED BY END-PRESSURE

a. UNIFORM INTERNAL PRESSURE p_1

Returning to the fundamental equations leading to differential equation [4.55], it is to be noted that the tube is closed by end bulkheads (Figure 12) and that the hydrostatic pressure $\pi r^2 p_1$ acting on the end bulkheads creates a longitudinal tensional stress

$$C_1^*) \quad \sigma_z'^* = \frac{\pi r^2 p_1}{2 \pi r s} = \frac{r p_1}{2 s} \quad [5.1]$$

while in the preceding Section 4 the longitudinal stress σ_z' was equal to zero. (All quantities deviating from those of the previous chapter are marked with an asterisk to distinguish them from those in 4.) It remains to investigate the influence that $\sigma_z'^*$, as distinguished from zero, exerts upon the equations, especially on the differential equation [4.55]. In the first place, Equation [4.98] is replaced by the equation

$$80) \quad \sigma_z'^* = \frac{r p_1}{2 s} = \frac{m^2 E}{m^2 - 1} \left(\epsilon_z'^* + \frac{\epsilon_z^*}{m} \right) \quad [5.2]$$

from which there results the relation for ϵ_z^{1*} as

$$\epsilon_z^{1*} = \frac{m^2 - 1}{m^2 E} \cdot \frac{r p_i}{2 s} - \frac{\epsilon_z^*}{m} \quad [5.3]$$

This value, if substituted in σ_z , as required in Equation [4.30], yields (according to Equation [4.42]):

$$\sigma_z^* = \frac{m^2 E}{m^2 - 1} \epsilon_z^* \left(1 - \frac{1}{m^2}\right) + \frac{1}{m} \cdot \frac{r p_i}{2 s} = E \epsilon_z^* + \frac{1}{m} \cdot \frac{r p_i}{2 s} \quad [5.4]$$

or making use of Equation [4.46]:

$$80a) \quad \sigma_z^* = \frac{E y^*}{r} + \frac{1}{m} \cdot \frac{r p_i}{2 s} \quad [5.5]$$

Finally, this relation is to be introduced into Equation [4.30] and we obtain:

$$\frac{d^2}{d x^2} \left(\frac{m^2 E}{m^2 - 1} \cdot \frac{s^3}{12} \cdot \frac{d^2 y^*}{d x^2} \right) - \frac{E s}{r^2} y^* - \frac{p_i}{2 m} + p_i = 0 \quad [5.6]$$

or

$$II^*) \quad \frac{d^4 y^*}{d x^4} - 12 \left(\frac{p_i}{E s^2} \cdot \frac{2m-1}{2m} - \frac{y^*}{r^2 s^2} \right) \frac{m^2 - 1}{m^2} = 0 \quad [5.7]$$

This is the differential equation of the elastic curve for a tube provided with end bulkheads, stiffened by frames, and subject to internal hydrostatic pressure. It differs from Equation [4.55] (free cylindrical tube) only in the factor $(2m - 1)/2m$ attached to the first term inside the brackets. For metals, the value of this factor is 0.85 and means a reduction in the influence of p_i on the magnitude of the deflection y . Under otherwise equal circumstances these deflections become smaller than those of the preceding chapter.

We write Equation [5.7] thus:

$$\frac{d^4 y^*}{d x^4} + \frac{m^2 - 1}{m^2} \cdot \frac{12}{r^2 s^2} \left(y^* - \frac{2m-1}{2m} \cdot \frac{r^2 p_i}{E s} \right) = 0 \quad [5.8]$$

put

$$\alpha^*) y^*) \quad y_\infty^* = \frac{2m-1}{2m} \cdot \frac{r^2 p_i}{E s} = z^* + y^* \quad [5.9]$$

and with the meaning of α as stated previously (according to Equation [4.59]) we obtain

$$II'*) \quad \frac{d^4 z^*}{d x^4} + 4 \alpha^4 z^* = 0 \quad [5.10]$$

From this we obtain

$$\text{II}_{42}^*) \quad y_{\infty}^* - y^* = \frac{y_{\infty}^* - y_0^*}{\text{Sin } \alpha l + \sin \alpha l} \times \\ \times [\text{Sin } \alpha x \cos \alpha (1-x) + \text{Cos } \alpha x \sin \alpha (1-x) + \\ + \sin \alpha x \text{Cos } \alpha (1-x) + \cos \alpha x \text{Sin } \alpha (1-x)] \quad [5.11]$$

Here, the fourth integration constant y_0^* (the compression of the frame) is still unknown. The determination of y_0^* and hence of $y_{\infty}^* - y_0^*$ takes exactly the same form as above until shortly after the place where the abbreviation β , which here has the same value, is introduced by means of Equation [4.106];¹ there in Equation [4.90] the new value of y_{∞}^* is now to be introduced in place of y_{∞} and we get

$$y_{\infty}^* - y_0^* = \frac{I}{I + \beta} \cdot \frac{r^2 p_i}{E s} \left(\frac{2m - I}{2m} - \frac{bs}{F + bs} \right) \quad [5.12]$$

or

$$\epsilon^{**}) \quad y_{\infty}^* - y_0^* = \left(\frac{2m - I}{2m} - \frac{bs}{F + bs} \right) \frac{r^2}{E s} \cdot \frac{p_i}{I + \beta} \quad [5.13]$$

Thus the equation for the elastic curve becomes

$$y_{\infty}^* - y^* = \frac{r^2 p_i}{E s} \cdot \frac{\frac{2m - I}{2m} - \frac{bs}{F + bs}}{(I + \beta)(\text{Sin } \alpha l + \sin \alpha l)} \times \\ \times [\text{Sin } \alpha x \cos \alpha (1-x) + \dots + \dots + \cos \alpha x \text{Sin } \alpha (1-x)] \quad [5.14]$$

or, solved for y^* :

$$84) \quad y^* = \frac{r^2 p_i}{E s} \left[\frac{2m - I}{2m} - \left(\frac{2m - I}{2m} - \frac{bs}{F + bs} \right) \right] \times \\ \times \frac{\text{Sin } \alpha x \cos \alpha (1-x) + \dots + \dots + \cos \alpha x \text{Sin } \alpha (1-x)}{(I + \beta)(\text{Sin } \alpha l + \sin \alpha l)} \quad [5.15]$$

¹Here the question is to be discussed, however, as to whether Equation [4.87] should not also be replaced by a new Equation [4.87'] for Equation [2.4] on which Equation [4.87] is based naturally does not apply to rings which are simultaneously subjected to radial and axial pressure. Actually, however, this kind of load exists in the strip of the shell of the cross section bs which rests on the flange of the frame, i.e., in a portion, at least, of the combination of the cross section $F + bs$ which is defined as "frame." Even though, as a result, Equation [4.87] no longer applies, strictly speaking we have nevertheless desisted from developing the equations for a "compound frame ring" ("Verbundspantring") composed of two rings fitted into one another where both the single rings are subjected to radial pressure while one of them (in our figures the outer one) is exposed to an axial pressure as well. This procedure is justified by the fact that in practical cases the cross section F of the frame usually considerably exceeds the cross section bs so that the great complication of the formulas resulting would not be worthwhile. Fundamentally, no difficulties are encountered in carrying out this calculation.

Now all stresses can be written

(1)

$$80) \quad \sigma_z'^* = \frac{r p_1}{2 s} = \text{constant} \quad [5.16]$$

(2a)

$$80a) \quad \sigma_z^* = \frac{r p_1}{s} \left[1 - \left(\frac{2 m - 1}{2 m} - \frac{b s}{F + b s} \right) \times \right. \\ \left. \times \frac{\sin \alpha x \cos \alpha (1-x) + \dots + \dots + \cos \alpha x \sin \alpha (1-x)}{(1 + \beta) (\sin \alpha l + \sin \alpha l)} \right] \quad [5.17]$$

(2b)

$$80'a) \quad \sigma_{z \max}^* = (\sigma_z^*)_{x=1/2} = \frac{r p_1}{s} \left\{ 1 - 2 \left(0.85 - \frac{b s}{F + b s} \right) \times \right. \\ \left. \times \frac{\sin \frac{\alpha l}{2} \cos \frac{\alpha l}{2} + \cos \frac{\alpha l}{2} \sin \frac{\alpha l}{2}}{(1 + \beta) (\sin \alpha l + \sin \alpha l)} \right\} \quad [5.18]$$

(3a)

$$\sigma_b^* = (y_{\infty}^* - y_0^*) \sqrt{\frac{3 m^2}{m^2 - 1}} \cdot \frac{E}{r} \quad [5.19]$$

$$\frac{\cos \alpha x \sin \alpha (1-x) - \sin \alpha x \cos \alpha (1-x) - \cos \alpha x \sin \alpha (1-x) + \sin \alpha x \cos \alpha (1-x)}{\sin \alpha l + \sin \alpha l}$$

$$= \frac{r p_1}{s} \sqrt{\frac{3 m^2}{m^2 - 1}} \left(\frac{2 m - 1}{2 m} - \frac{b s}{F + b s} \right) \frac{\cos \alpha x \sin \alpha (1-x) - \dots - \dots + \sin \alpha x \cos \alpha (1-x)}{(1 + \beta) (\sin \alpha l + \sin \alpha l)} \quad [5.20]$$

$$= \frac{r p_1}{s} 1.815 \left(0.85 - \frac{b s}{F + b s} \right) \frac{\cos \alpha x \sin \alpha (1-x) - \dots - \dots + \sin \alpha x \cos \alpha (1-x)}{(1 + \beta) (\sin \alpha l + \sin \alpha l)} \quad [5.21]$$

(3b)

$$80'b) \quad \sigma_{b \max}^* = (\sigma_b^*)_{x=0} = \frac{r p_1}{s} 1.815 \left(0.85 - \frac{b s}{F + b s} \right) \frac{\sin \alpha l - \sin \alpha l}{(1 + \beta) (\sin \alpha l + \sin \alpha l)} \quad [5.22]$$

(4a)

$$\sigma_b'^* = \frac{1}{m} \sigma_b^* \quad [5.23]$$

$$\begin{aligned}
 (4b) \quad & (\sigma_b'^*)_{1/2} = \frac{r p_i}{s} 0.545 \left(0.85 - \frac{b s}{F + b s} \right) \frac{2}{1 + \beta} \times \\
 80'c) \quad & \times \frac{\text{Sin} \frac{\alpha l}{2} \cos \frac{\alpha l}{2} - \text{Cof} \frac{\alpha l}{2} \sin \frac{\alpha l}{2}}{\text{Sin} \alpha l + \sin \alpha l} \quad [5.24]
 \end{aligned}$$

The two stresses determinative for safety are found at the points $x = 0$ and $x = l/2$ and are respectively $\sigma_z'^* + \sigma_b^*_{\max}$ and $\sigma_z^*_{\max} + \sigma_b'^*_{1/2}$; as a rule the former pair gives the greater value. The conditions for the nonappearance of greater permanent strains are therefore

$$\begin{aligned}
 82) \quad & \sigma_z'^* + \sigma_b^*_{\max} = \frac{r p_i}{s} \left[\frac{1}{2} + 1.815 \left(0.85 - \frac{b s}{F + b s} \right) \times \right. \\
 & \left. \times \frac{\text{Sin} \alpha l - \sin \alpha l}{(1 + \beta)(\text{Sin} \alpha l + \sin \alpha l)} \right] < \sigma_{fz} \quad [5.25]
 \end{aligned}$$

and

$$\begin{aligned}
 82a) \quad & \sigma_z^*_{\max} + \sigma_b'^*_{1/2} = \frac{r p_i}{s} \left[1 - 2 \left(0.85 - \frac{b s}{F + b s} \right) \times \right. \\
 & \left. \times \frac{0.455 \text{Sin} \frac{\alpha l}{2} \cos \frac{\alpha l}{2} + 1.545 \text{Cof} \frac{\alpha l}{2} \sin \frac{\alpha l}{2}}{(1 + \beta)(\text{Sin} \alpha l + \sin \alpha l)} \right] < \sigma_{fz} \quad [5.26]^1
 \end{aligned}$$

Otherwise, all that was said in the last section in regard to Equation [4.98] and the following equations hold true in this case. We shall only consider briefly the special case $F = \infty$ ($\beta = 0$) which gives

$$\sigma_b^*_{\max} = \frac{r p_i}{s} 1.554 \frac{\text{Sin} \alpha l - \sin \alpha l}{\text{Sin} \alpha l + \sin \alpha l} \quad [5.27]^2$$

If further, $\alpha l > \pi$, the trigonometric fraction becomes equal to unity and we obtain

$$\sigma_z'^* + \sigma_b^*_{\max} = 2.054 \frac{r p_i}{s} \quad [5.28]^2$$

Translator's Notes:

¹As corrected by W. Hovgaard (Memorandum No. 88, opp. p. 47), this formula should read:

$$\begin{aligned}
 \sigma_z^*_{\max} + (\sigma_b'^*)_{1/2} &= \frac{r p_i}{s} \left[1 - 2 \left(0.85 - \frac{b s}{F + b s} \right) \right. \\
 & \left. \frac{1.545 \sinh \frac{\alpha l}{2} \cos \frac{\alpha l}{2} + 0.455 \cosh \frac{\alpha l}{2} \sin \frac{\alpha l}{2}}{(1 + \beta)(\sinh \alpha l + \sin \alpha l)} \right] < \sigma_{fz}
 \end{aligned}$$

²In place of the numerical values in Equations [5.27] and [5.28] Hovgaard suggests substituting the following: 1.543 for 1.554 and 2.043 for 2.054.

which is 105.4 percent greater than the tangential tensile stress according to Equation [3.1] which was formerly considered determinative.

Otherwise, the conclusions drawn at the end of the preceding Section 4 hold here also. The formula for the axial elastic displacement u^* becomes

$$\frac{du^*}{dx} \equiv \epsilon'^* = \frac{m^2 - 1}{m^2 E} \cdot \frac{r p_i}{2s} - \frac{\epsilon_z^*}{m} \quad [5.29]$$

$$= \frac{m^2 - 1}{m^2 E} \cdot \frac{r p_i}{2s} - \frac{y^*}{m r} \quad [5.30]$$

consequently

$$85) \quad u^* = \frac{m^2 - 1}{m^2 E} \cdot \frac{r p_i}{2s} x - \frac{1}{m r} \int_0^x y^* dx \quad [5.31]$$

where y^* must still be inserted from Equation [5.15] and where the integration is still to be performed.

The formulas of this section were used in February 1918 by the Germaniawerft and in April 1918 were communicated to U-boat Inspection in Kiel; we are here satisfying the repeatedly expressed desire to have the derivation of these formulas published (see also Johow-Foerster, 4th Edition, Section: Unterwasserfahrzeuge).

b. UNDER EXTERNAL PRESSURE p_a

Just as in the case of the free cylindrical tube stiffened by transverse frames, the formulas [5.2] to [5.24] are transformed into the corresponding formulas for external pressure by substituting p_a for p_1 , and simultaneously, σ_d^* and $\sigma_d'^*$ for σ_z^* and $\sigma_z'^*$, respectively. By σ_b^* and $\sigma_b'^*$, on the other hand, we now understand the additional compressive stresses on the surface of the shell which are the result of bending. The conditions corresponding to the Equation [5.25] and [5.26] (stress calculation)

$$\sigma_d'^* + \sigma_b^* \max < \sigma_{fd} \quad \text{and} \quad \sigma_d^* \max + \sigma_b'^* / 2 < \sigma_{fd} \quad [5.32]$$

if solved for p , result in

$$92) \quad p_a < \frac{\frac{s}{r} \sigma_{fd}}{\frac{1}{2} + 1.815 \left(0.85 - \frac{b s}{F + b s} \right) \frac{\text{Sin } \alpha l - \sin \alpha l}{(1 + \beta) (\text{Sin } \alpha l + \sin \alpha l)}} \quad [5.33]$$

$$92a) \quad p_a < \frac{\frac{s}{r} \sigma_{f,d}}{1 - 2 \left(0.85 - \frac{bs}{F + bs} \right) \frac{0.455 \sin \frac{\alpha l}{2} \cos \frac{\alpha l}{2} - 1.545 \cos \frac{\alpha l}{2} \sin \frac{\alpha l}{2}}{(1 + \beta)(\sin \alpha l + \sin \alpha l)} \quad [5.34]^1, 3$$

It is true that, as in all former cases, the conditions [5.33] and [5.34] are necessary, but no longer sufficient. v. Mises, in a memorandum submitted to U-boat Inspection early in 1918, adapted his investigations to the conditions prevailing when end-pressure exists, parallel to the formulas of Section 4 but extended by taking into account the effect of end-pressure. His modified formula (which was communicated to the shipyards participating in the model tests) for use in connection with strength-hull calculations reads as follows:

$$96) \quad p_k^* = \left\{ \frac{\frac{E}{n^2}}{\left[1 + \left(\frac{n}{\pi} \cdot \frac{l}{r} \right)^2 \right]^2} \cdot \frac{s}{r} + \frac{n^2 \left[1 + \left(\frac{\pi}{n} \cdot \frac{r}{l} \right)^2 \right]^2 \frac{m^2 E}{m^2 - 1} \left(\frac{s}{r} \right)^3}{12} \right\} \frac{1}{1 + \frac{1}{2} \left(\frac{\pi}{n} \cdot \frac{r}{l} \right)^2} \quad [5.35]^2$$

It represents an already simplified form which gives good approximate values for at least eight to ten bulges on the circumference. Under these conditions, Equation [4.126] may also be written in an even simpler form since in that case unity may be neglected in comparison with n^2 and $\frac{m+1}{m} = 1.3$ compared with $2n^2$; see Gumbel, *ibid.* Equation [4.126] then becomes

Translators' Notes:

¹As corrected by W. Hovgaard (Memorandum No. 88, opp. p. 48), this formula should read:

$$p_a < \frac{\frac{s}{r} \sigma_{f,d}}{1 - 2 \left(0.85 - \frac{bs}{F + bs} \right) \frac{1.545 \sinh \frac{\alpha l}{2} \cos \frac{\alpha l}{2} + 0.455 \cosh \frac{\alpha l}{2} \sin \frac{\alpha l}{2}}{(1 + \beta)(\sinh \alpha l + \sin \alpha l)}$$

²W. Hovgaard (Memorandum No. 88, opp. p. 48), elaborates on this formula as follows:

$$p_a = \left\{ \frac{\frac{E}{n^2}}{\left[1 + \left(\frac{n}{\pi} \cdot \frac{l}{r} \right)^2 \right]^2} \cdot \frac{s}{r} + \frac{n^2 \left[1 + \left(\frac{\pi}{n} \cdot \frac{r}{l} \right)^2 \right]^2 \cdot E \cdot \frac{m^2}{m^2 - 1} \left(\frac{s}{r} \right)^3}{12} \right\} \cdot \frac{1}{1 + 0.5 \left(\frac{\pi}{n} \cdot \frac{r}{l} \right)^2}$$

$$p_a = E \left(\frac{s}{r} \right) \left\{ \frac{1}{n^2} \frac{1}{\left[1 + \frac{1}{9.87} \left(\frac{nl}{r} \right)^2 \right]^2} + 0.0916 n^2 \left(\frac{s}{r} \right)^2 \left[1 + 9.87 \left(\frac{r}{nl} \right)^2 \right]^2 \right\} \frac{1}{1 + 4.98 \left(\frac{r}{nl} \right)^2}$$

³Annotators' Note: It is to be noted that the derivation of this expression neglects the effective radial pressure caused by the axially applied stress resultant. V.L. Salerno and J. Pulos in a forthcoming report to be published by the Polytechnic Institute of Brooklyn have taken proper account of this effect. Their investigation indicates that the peripheral load supported by a frame may be as much as 25 percent below that obtained by von Sanden and Gunther. They also found that both the longitudinal and circumferential stresses vary considerably from the values predicted by von Sanden and Gunther.

$$761) \quad p_k = \frac{\frac{E}{n^2}}{\left[1 + \left(\frac{n}{\pi} \cdot \frac{1}{r}\right)^2\right]^2} \frac{s}{r} + \frac{n^2}{12} \left[1 + \frac{2}{1 + \left(\frac{n}{\pi} \cdot \frac{1}{r}\right)^2}\right] \frac{m^2 E}{m^2 - 1} \left(\frac{s}{r}\right)^3 \quad [5.36]$$

and shows a great deal of similarity to Equation [5.35].

Moreover, the statements made at the end of the previous Section 4 with respect to the relation between calculations for stress and stability, etc., apply here in the same manner; the effect of the end-pressure does not basically change conditions in any way.

Without taking up in detail in this general discussion the many other problems involved, we shall only give here (explicitly) the expression for the total radial load p per cm of circumference of the frame to be inserted in the re-calculation of stresses and stability of the frame. From Equation [4.87] there results (for internal or external pressure)

$$p = E (F + b s) \frac{y_0}{r^2} \quad [5.37]$$

where, in the case of the free tube open at the ends, y_0 is to be taken from [4.95]. y_0 , which is the radial elastic expansion or contraction of the frame, is a most important quantity in experimental work. We find

$$y_0 = \frac{r^2 p}{E s} \left\{ 1 - \frac{F}{(1 + \beta)(F + b s)} \right\} = \frac{p}{1 + \beta} \cdot \frac{r^2}{E s} \left(1 + \beta - \frac{F}{F + b s} \right) \quad [5.38]$$

and consequently

$$68) \quad p = \frac{p}{1 + \beta} \left[(1 + \beta) \left(\frac{F}{s} + b \right) - \frac{F}{s} \right] = p \left(b + \frac{\beta}{1 + \beta} \cdot \frac{F}{s} \right) \quad [5.39]$$

For the tube under end-pressure, we obtain from [5.13] and [5.9]

$$y_0^* = \frac{r^2 p}{E s} \left(\frac{2m - 1}{2m} \cdot \frac{\beta}{1 + \beta} + \frac{b s}{F + b s} \cdot \frac{1}{1 + \beta} \right) \quad [5.40]$$

$$= \frac{r^2}{E s} \cdot \frac{p}{1 + \beta} \left(0.85 \beta + \frac{b s}{F + b s} \right) \quad [5.41]$$

and hence from Equation [4.87]

$$88) \quad p^* = \frac{P}{1 + \beta} \left[0.85 \beta \left(\frac{F}{s} + b \right) + b \right] \quad [5.42]^1$$

Equations [5.39] and [5.42] permit us to trace the important influence of the frame spacing and the frame section on the frame load.

The frame spacing l occurs only in the quantity β defined above by [4.106] and is here present only in the fraction

$$\frac{\cos \alpha l - \cos \alpha l}{\sin \alpha l + \sin \alpha l}$$

which, as shown above, is proportional to the shear stress V_0 transmitted from the "shell plating" (of length l) to the "frame" (section $F + bs$). As mentioned above, as soon as αl exceeds $(3/2)\pi$, i.e., $l > 3.67 \sqrt{rs}$, the above fraction asymptotically approaches unity so that

$$\eta') \quad \beta = \frac{1.555 \sqrt{s^3 r}}{F + bs} \quad [5.43]$$

and p and p^* as a result become independent of l . We obtain

$$68') \quad p = p \left[b + \frac{1.555 \sqrt{s r}}{1 + (bs + 1.555 \sqrt{s^3 r})/F} \right] \quad [5.44]$$

and

$$88') \quad p^* = \frac{P}{1 + \frac{1.555 \sqrt{s^3 r}}{F + bs}} (b + 1.32 \sqrt{s r}) \quad [5.45]$$

If in these two equations we imagine the above fraction to be inserted as a factor everywhere before the radical sign, we obtain the expressions for p and p^* with unabridged β , and in a form, to be sure, which makes it possible to judge the influence of F and more especially the limiting condition $F = \infty$ (the case of a bulkhead). It is clear that p and p^* increase

¹Translator's Note: For comparison with [5.39], [5.42] can be written:

$$p = p \left[\frac{b(1 + 0.85\beta)}{(1 + \beta)} + \frac{0.85\beta \cdot F}{1 + \beta} \cdot \frac{1}{s} \right]$$

when F increases so that for $F = \infty$ we obtain^{1,2}

$$68") \quad p = p \left(b + 1.32 \frac{\cos \alpha l - \cos \alpha l}{\sin \alpha l + \sin \alpha l} \sqrt{s r} \right) \quad [5.46]$$

and

$$88") \quad p^* = p \left(b + 1.32 \frac{\cos \alpha l - \cos \alpha l}{\sin \alpha l + \cos \alpha l} \sqrt{s r} \right) \quad [5.47]$$

In conclusion, without claiming to exhaust the subject completely, we shall give a review of the forms of empirical and semi-empirical formulas which have been applied to this difficult problem (see Radiguer, *La Navigation sous-marine*, Paris, 1911).

1. Fairbairn:

$$s = c_0 \sqrt[2.19]{p l r} \text{ d. h. } p = c'_0 \frac{s^{2.19}}{l r} \quad [5.48]$$

2. Love:

$$p = c_1 \frac{s^2}{l r} + c_2 \frac{s^2}{r} + c_3 \frac{s}{r} \quad [5.49]$$

In these two formulas, p denotes the destructive pressure; since not only ratios of the linear dimensions occur in them and since, consequently, their results depend on the absolute size of the tubes, the constants cannot claim any general validity. In the following formulas p denotes the permissible pressure.

3. C. v. Bach:

$$p = \frac{25\,000 \left(\frac{s}{r} \right)^2}{50 \cdot \frac{s}{r} + (2 \div 2.5) \frac{l}{1 + 2 \cdot \frac{r}{l}}} \quad [5.50]$$

¹When p or p^* , respectively, is determined, the moment of inertia of the frame angle shell strip (of width b) referred to the axis of the common center of gravity must be inserted in re-calculating the "frame" with respect to buckling (according to Equation [2.7]). The reduction of p or p^* , respectively, to the neutral fibre must be made.

²In contrast to Equation [5.39], Equation [5.44] does not yield the value pb for the limiting case $F=0$ which is practically insignificant, yet theoretically important; this results from the conditions which have been discussed in connection with the setting up of Equation [5.13] in the corresponding footnote.

4. Wehage:

$$p = 36\,000 \frac{l}{r} \sqrt[3]{\frac{s}{lr}} \quad [5.51]$$

It is seen that only Bach's formula depends solely on the ratios between the linear dimensions, as it should be. It is interesting to see that despite many experiments and the application of much technical ingenuity, it has proved impossible to arrive empirically at the true relation between p and the ratios s/r and l/r . In view of this, it is easy to understand that under the influence of breakdowns or theoretical considerations people for a long time turned in uncertainty from one formula to another.

The course of the historical development was roughly as follows: First the formula of Love was used; it dealt especially with the instability of the shell and was fairly satisfactory for this purpose although it gave rather high values of p . Then people turned to the Föppl-Hurlbrink formula for collapse of a frame, regarding the shell merely as a part of the frame, while Horn's stress calculations for the shell were regarded as doubtful. The ever-increasing relative weakening of the shell by increased depths of immersion and the excessive strengthening of the frames made it necessary to enter the path of the general theory of elasticity which finally, in conjunction with experiments, made it possible to solve the problem completely and to throw light on its smallest details.

By utilizing the know-how thus acquired it became possible to raise the coefficient of efficiency

$$\eta = \frac{\text{immersed volume per m length}}{\text{weight per m length}} \times \text{maximum depth of immersion}$$

from 0.3 to more than 1.5. A model of 900 mm diameter and 2.4 mm thickness of shell plating carried an external pressure of 250 m head of water without suffering any permanent deformations.

In conclusion, I wish to express my keen appreciation to Dr. Techel for the assistance rendered to me on many occasions in dealing with this entire problem and for many stimulating suggestions offered in connection with this investigation.

**PART II - EXPERIMENTS AND PRACTICAL APPLICATIONS
OF THE THEORY DEVELOPED IN PART I**

6. EXPERIMENTS WITH MODELS OF STRENGTH HULLS OF SUBMARINES

The first part of this treatise* offers a systematic treatment of the problem of the strength of ring frames and hollow cylinders which are subject to uniform external pressure and it leads up to a description of the calculation of the cylindrical tube stiffened by transverse frames and loaded by uniform end-pressure and radial pressure. One of the most important applications of this latter case consists in the calculation of the strength hulls of submarines whose stresses, strictly speaking, are even somewhat more complicated since the loading due to water pressure increases uniformly from the upper edge to the lower edge of the strength hull while additional stresses occur due to its own weight, installations and appendages. In fact, as already pointed out in the introduction, the problem of the strength of the hulls of submarines gave rise to these investigations which produced a solution for it in all the essential aspects while disregarding the complications just mentioned. Unfortunately, this solution which in its basic aspects was definitely established early in 1918 and the systematic application of which was bound to be of decisive importance for the construction of strength hulls of large submarines designed for great depths of immersion came to be used only in a few cases of minor significance as far as German submarines were concerned. It is true that approximate methods of calculation and practical experience had made it possible even before this to increase the depth of immersion without increasing the hull weight materially. But only the solution described here, which was arrived at on the basis of the theory of elasticity and numerous experiments, made it possible to design the various members of the strength hull of a submarine in such a way that the prescribed depth of immersion could be achieved for a given strength hull with a minimum of hull weight, i.e., the strength hull could be constructed as lightly as the strength properties of the material in question permitted.

In Germany the determination of the scantlings of strength hulls of submarines was for a long time based on the methods of calculation developed by Föppl-Hurlbrink and Marbec. Both of these methods deal with the collapse

*The articles in question were published in Numbers 8, 9, and 10 of "Werft and Reederei" for 1920. The vast scope of numerical calculations, e.g., of those on which Figures 5 and 6 of the present article are based, delayed the publication of this second part more than had been anticipated originally. Nevertheless, it seemed wise to await the completion of the calculation of a numerical example in order to point out more sharply the concrete results of the theory and to facilitate its application for engineers who are not too familiar with the mathematical principles involved.

by instability ("Einknickungsdruck") of frame rings under radial loads based upon the assumption that a portion of the strength hull of the length of one frame space (including frame and plating) can be regarded as an isolated ring, i.e., independent of the adjacent material. It is assumed further that the strength depends essentially on the scantlings of the frame, while the shell plating is regarded merely as a flange of the frame. It is immediately apparent that for geometric as well as physical reasons this conception might prove to be disastrous to the proper design of strength hulls. Actually, the strength hull of a submarine is not simply a collection of rings held together in some way or other, but a complete hollow body, in the simplest case a closed hollow cylinder. It follows that the shell plating and not the frame is the most important element of construction. Nevertheless, up until very recently designers limited themselves essentially to the calculation of the strength of the frames with the result that the latter were generally made too heavy while the strength of the shell was unconsciously reduced to its lowest permissible limit.

In any event, the designers concerned had long recognized the insufficiency of the available methods of calculation and along with the progress of submarine design greater depths of immersion came to be required; the attempt was made to determine the pressure of collapse (Einknickungsdruck) by means of practical experiments in the absence of a reliable theory. The first pressure tests with strength-hull models which were carried out by the German Navy in 1913 were still based entirely on the views of Hurlbrink and Marbec as far as their set-up, execution and analysis were concerned. Preparations were made to construct for the new larger submarines a type of strength hull, the section of which—partly under the influence of the Fiat-boat construction—deviated from the simple circular form. Previous to this, the well-known U-boat specialist of the Navy, Dr. Ing. H.C. Werner, had already advocated the idea of adopting for larger U-boats the design of two strength hulls* of relatively small diameter placed parallel to each other. As soon as he was made the head of the U-boat section of Torpedo-Inspection he resumed this project and his assistant, Kuchler, subsequently developed a type of twin body, the cross section of which consisted of two circular sections intersecting each other. Thus, in addition to the actual strength-hull compartments there came to be a central corridor connecting the latter

*Reference is made also to the patent held by the Germania Shipyard on triple strength hulls and Bake's patent concerning multiple intermediate strength hulls of U-boats.

which likewise had to have enough strength to withstand the full pressure of the water. In constructing this type of a body it was clearly realized that the central corridor especially constituted a great source of weakness and that it could only be strengthened sufficiently at the expense of a great weight of material. For this and other reasons the corridor, even in the project stage, was largely replaced by stanchions. For the model pressure test the compartments were selected which contained the Diesel engines and electric motors and which were separated from each other by a strength bulkhead and thus the cross section with stanchions as well as that with the central corridor could be tested. As the mathematical calculation demonstrates very easily, the strength of the frame depended entirely on either keeping the distance between the intersecting points of the two circular sections constant or on allowing a very small deflection. The second of the above authors of this article, who was carrying out the calculations, from the very beginning called attention to the fact that the central-corridor construction would probably prove to be too weak. As a matter of fact, the compartment containing the electric motors, which was supported by stanchions and whose vertical deflection could be made equal to zero, withstood all the stresses whereas, in the compartment housing the Diesel engines the shell between the frames bulged in after the latter had first yielded excessively. Unfortunately, however, at that time not a great deal of attention was paid to the deformations of the shell since the deflections of the frames were considered to be of paramount importance. The central-corridor construction was abandoned and the Danzig Navy Yard which had carried out the model pressure tests prepared an alternate project to test a strong elliptic section stiffened by stanchions along the center line. The model tests conducted with this section, in which the shell had been strengthened above and below according to the greater radius of curvature, naturally yielded results similar to those with the first project since again only the strength of the frames was taken into account. The elliptic section, however, was somewhat more favorable with respect to the general utilization of space.

During the war the construction of these boats was set aside because of other more urgent projects but it was taken up again later on. For the time being a slightly elliptic strength-hull section was adopted in the preliminary project on the basis of the experiments just described. At the same time, the system of external framing which was hitherto used only by the Danzig Shipyard was prescribed in the specifications. The Germania Shipyard had serious objections of a practical and theoretical nature against this type of construction and offered to prove by extensive model experiments the superiority of the hitherto used construction with circular section and

internal frames. These tests finally brought out the fact that the strength of the frames was sufficient in both constructions as hitherto adopted but that it was necessary to pay more attention to the strength of the shell. At the same time, when the experiments carried out at the Danzig Shipyard were compared with those of the Germania Yard, it was realized even then that the results of the model tests, which had by no means been carried out with the precision customary in scientific laboratories, had to be accepted with great caution, and that, in any event, the models should be made to the largest possible scale.

Hence, the following questions remained to be answered:

A. What is the influence of the scale of the models on the pressure of collapse?

B. What is the influence of the framing on the strength against collapse (Knickfestigkeit) of the shell?

and in particular,

1. What is the influence of the frame spacing on the shell?

2. What is the influence of the strength of the individual frames upon the shell?

In order to investigate these problems the U-boat Inspection and the Danzig Navy Yard in the summer of 1917 jointly prepared a new testing program which was carried out with the utmost speed.

The experimental Series 1 dealing principally with answering questions A and B1 comprised altogether ten models of four different diameters, the dimensions of which can be seen from the accompanying figures and tables. The models Ia, IIa, IIIa, IVa, as well as the models Ib, IIb, IIIb, IVb, and Ic and IIc are geometrically similar (see Figures 29 and 30).

With respect to the design of the experimental models the following should be noted: The middle portion of the cylinder of length l between the two frames is to be regarded as the true experimental cylinder. The distance

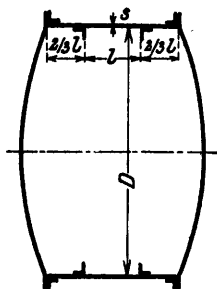

Figure 29 - Experimental Model
with Two Frames

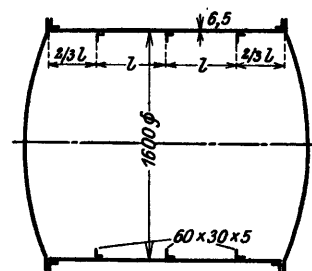

Figure 30 - Experimental Model
with Three Frames

of the frames from the bottoms was made equal to $2/3 l$ in order to protect the middle portion as far as possible against the arch effect of the bottoms, which were designed to be strong and therefore subject to minor deformations only. Moreover, this distance was chosen so as to prevent collapse of the shell between the frame and the bottom before collapse of the shell between the frames. The frames themselves were given unusual strength in order to be able to preserve with certainty the circular form at the ends of the models.

Internal pressure in the cylinders was produced by compressed air, external pressure by water, and the pressure was increased until the drop of the pointer of the manometer indicated that bulging (Einbeulen) had taken place. This moment of bulging was always defined very sharply by the position of the manometer pointer. It is true, of course, that these tests could produce no more than approximate comparative values and that only the critical pressure could be tested, whereas gradual deformations that might have occurred previously could not be observed. Nevertheless, these experiments furnished practical data which were the foundation for further theoretical advancement. It was possible to observe clearly the formation of bulges in all the models in Series 1 and the number of bulges agreed perfectly with the number predicted by the v. Mises formulas mentioned in Part I. The collapse pressure varied a great deal according to the size of the various cylinders under compression although theoretically similar cylinders should have shown the same collapse pressure. Basically, this may be explained by the fact that in the smaller cylinders the inaccuracies of workmanship were relatively greater and that the 2 and 3 mm plates themselves were not entirely uniform, with the result that the cylinder which was supposed to be circular actually deviated from the circular form considerably. Therefore, with reference to question A, these experiments showed that the test results obtained could not be applied safely to the strength hulls of submarines unless the thickness of the plating used in the models was above 4 mm.

In contrast to the number of bulges the observed collapsing pressure did not in all models check completely with the results of v. Mises' formulas, due to the fact that the prerequisites of the latter were no longer fulfilled in some of the models since the stresses which occurred at the calculated collapsing pressure considerably exceeded the limit of proportionality.

In a memorandum to the Inspector of Submarines, v. Mises himself tried to modify his formula for these latter cases by the use of Tetmajer's buckling experiments. This method of calculation is applicable so long as the stresses which occur under collapsing pressure do not greatly exceed the elastic limit. It may be refined even more with the help of v. Kármán's

investigations.* If the stresses corresponding to v. Mises' collapsing pressure are materially higher than the elastic limit, it means that we are no longer dealing with sudden collapse (i.e., instability); instead of this, the model suffers a gradual deformation due to the fact that the permissible stress is exceeded. In this case, instead of the sudden appearance of individual bulges, a uniform inward bulging takes place over the entire circumference (Einschnürung) as demonstrated by the experiments of the Germania Shipyard.

The experimental Series 2 comprised three models, V1, V2, and V3 of 1600 mm diameter, 6.5 mm thickness of plating, and frame angles of $60 \times 30 \times 5$ mm placed with spacings of 400, 500 and 600 mm respectively; even as a first test, it served primarily to clear up question B2.

In the experiments with V1 and V2 the frames proved, indeed, to be too weak and therefore a formation of bulges as regular as in Series 1 did not result in these models. Model V3, on the other hand, was a typical case for the application of v. Mises' theory of collapse. Moreover, the reader's attention is called to Table I if he wishes to examine these tests critically.**

An especially remarkable result of the second series of tests is the paradoxical fact that in the case of strength hulls of the same diameter and same plate thickness, the frame must be strengthened when the frame spacing is reduced.† This is explained by the fact that the shell acts only very imperfectly as a flange for the frames. In practical cases it is well to include in the frame section only a strip of plating having the same width as the flange of the frame; hence, a constant moment of inertia of the frame is involved. The result is that the collapsing pressure of the frame remains constant, independent of the frame spacing, while the collapsing pressure of the shell increases when the frame spacing is reduced. In determining the scantlings we must, therefore, first determine the collapsing pressure of the plating for a given frame spacing and then make the frame so strong that it will hold even when the shell has collapsed by bulging. In practice, it should be sufficient to give the frames an excess strength of about 10 percent.

The experiments of the Germania and Danzig Shipyards herein described or referred to, together with other published experiments, served as a basis for the theoretical treatment of Part I of this report. Further, it had been

*See Part I, Sections 1 and 4b.

**Annotators' Note: Attention is directed to a more recent series of hydrostatic pressure tests of ring-stiffened cylindrical shells carried out at the U.S. Experimental Model Basin. The results of these tests are presented in Report 385 (loc. cit. p.12).

†Annotators' Note: This is the so-called "hard spot" effect.

TABLE 1

Table Illustrating the Pressure Tests with Model Cylinders

No. of Series	No. of Model	Dimensions and Scantlings				Observed Collapsing Pressure atm	Mode of Bulging		Remarks	
		Diameter D = 2r mm	Thickness of Plating s mm	Scantlings of Frame Angles	Frame Spacing i' mm		Length of Individual Bulges approx. mm	No. of Bulges All Around Circumference approx.		
1	Ia	800	2	40 × 25 × 4	120	6.1	140-150	17		
	Ib	800	2	40 × 25 × 4	180	3.0	160-170	15		
	Ic	800	2	40 × 25 × 4	240	3.35	170-180	14		
	IIa	1200	3	60 × 37.5 × 6	180	7.0	200-240	17		
	IIb	1200	3	60 × 37.5 × 6	270	5.1	250-260	15		
	IIc	1200	3	60 × 37.5 × 6	360	4.15	~280	13-14		
	IIIa	1600	4	80 × 50 × 8	240	>12.2	-	-	The test IIIa had to be discontinued on account of leakage in the pressure reservoir. It was not possible to determine why the strength of this model differs so radically from that of the other models.	
	IIIb	1600	4	80 × 50 × 8	360	6.0	300-400	14-15		
		IVa	2400	6	120 × 75 × 12	360	9.5	450-500	16	
		IVb	2400	6	120 × 75 × 12	540	7.2	500-550	14-15	
2	V1	1600	6.5	60 × 30 × 5	400	12.2	?	?	Frames collapsed.	
	V2	1600	6.5	60 × 30 × 5	500	9.2	?	?	Frames broke.	
	V3	1600	6.5	60 × 30 × 5	600	8.5	350	14-15		

our intention to confirm the theory thus developed by a new test program which was to comprise both the regions of stress and collapse (instability) as well as the intermediate uncertain region; however, the preparations made by the Danzig Yard in this direction could not, unfortunately, be carried to completion on account of the general breakdown. But, since these investigations are valuable not only in the design of submarines, but also in other branches of engineering, industry would render a great service if it undertook to test this theory more thoroughly on the basis of these preliminary results and, in particular, to determine the proper working stresses and thus the required factors of safety. Such tests could best be carried out in scientific laboratories for the testing of materials.

7. PRACTICAL EXAMPLES

The practical examples worked out in the following are intended to show the designer how to use the formulas developed in Part I in the calculations for strength hulls of submarines; moreover, they are expected to make a contribution toward the solution of the problem to which we have already referred several times, namely, that of designing a strength hull for a given depth of immersion and the resultant water pressure on the minimum weight of material. According to Section 5b of Part I the formulas [5.33], [5.34], and [5.35] serve to calculate the collapsing pressure of closed cylindrical reservoirs such as strength hulls of submarines in their simplest form; i.e., formulas [5.33] and [5.34] are to be used for stress calculations and [5.35] for collapse calculations. Before carrying out any numerical calculations, formula [5.33] will be briefly discussed and modified so as to reduce the auxiliary quantities which occur in it to a more convenient form. The formula is

$$p_a < \frac{\frac{s}{r} \sigma_{fd}}{\frac{1}{2} + 1.815 \left(0.85 - \frac{bs}{F + bs} \right) \frac{\text{Sin } \alpha l - \sin \alpha l}{\text{Sin } \alpha l + \sin \alpha l} \frac{1}{1 + \beta}} \quad [5.33]$$

As pointed out before, the yield point is to be used for the stress σ_{fd} . According to the experiments it can be assumed to be approximately 2950 kg/cm².

Furthermore, we have

$$\alpha = \sqrt[4]{\frac{m^2 - 1}{m^2} \cdot \frac{3}{s^2 r^2}} = \frac{1.285}{\sqrt{rs}} \quad [4.107]$$

$$\beta = \frac{2}{3} \sqrt[4]{\frac{27 m^2}{m^2 - 1} \cdot \frac{\sqrt{rs^3}}{F + bs} \cdot \frac{\text{Cos } \alpha l - \cos \alpha l}{\text{Sin } \alpha l + \sin \alpha l}} \quad [4.92]$$

For the sake of simplicity, the expressions

$$\frac{\csc \alpha l - \sin \alpha l}{\csc \alpha l + \sin \alpha l} \quad \text{and} \quad \frac{\cot \alpha l - \cos \alpha l}{\csc \alpha l + \sin \alpha l}$$

which occur again and again in the following discussion are designated by L and N respectively and may be obtained from Table 2 or the accompanying diagram (see Figure 31).

The quantity β may then be written simply in the form

$$\beta = \frac{2 N s}{\alpha (F + b s)} \quad [7.1]$$

and can be readily calculated when α has been determined. After introducing L, formula [5.33] finally becomes

$$P_a < \frac{2950 \frac{s}{r}}{\frac{1}{2} + 1.815 \left(0.85 - \frac{b s}{F + b s} \right) \frac{L}{1 + \beta}} \quad [7.2]$$

We shall first examine two cylindrical buoyancy tanks of equal size but of widely different scantlings which were constructed for the same class of boats by two different firms. Both tanks had the same diameter of 800 mm and the same length of 5200 mm. But, while one designer had given the tank a plate thickness of 4 mm and a frame angle of 60 × 40 × 5 mm, placed 235 mm apart, the other had given the second tank a plate thickness of 7 mm and a frame angle of 75 × 50 × 7 mm, placed 834 mm apart. The purpose of such tanks was, of course, to improve the conditions of stability by placing them on a high level in the boats and to create displacement on a minimum weight of material, i.e., to raise the center of buoyancy. It is important, in this case especially, to save as much weight as possible consistent with the safety of the construction against collapse. In judging the latter we can therefore disregard the technical reasons which, with a view to the operational problems involved, lead to the adoption of one construction or another, while aiming only at the greatest economy of production. The only basis on which to judge the quality of the two constructions is therefore the strength and lightness (weight) of the tanks.

The first tank had a frame spacing $l' = 235$ mm, and as the width of the flange connected to the plating was 40 mm, the unsupported part of the shell had a free length $l = 23.5 - 4 = 19.5$ cm.

We have

$$\alpha = \frac{1.285}{\sqrt{40 \cdot 0.4}} = 0.321 \quad [7.3]$$

$$\alpha l = 0.321 \cdot 19.5 = 6.26 \quad [7.4]$$

$L = N = 1$ (from the diagram Figure 31)

$$\beta = \frac{2 \cdot 1 \cdot 0.4}{0.321 (4.79 + 4 \cdot 0.4)} = 0.39 \quad [7.5]$$

$$p_a = \frac{2950 \cdot \frac{0.40}{40}}{0.5 + \frac{1.815 (0.85 - 0.251)}{1.39}} = 23.02 \text{ atm} \quad [7.6]^*$$

Since the buoyancy tank was designed for a pressure of $1.25 \times 7.5 = 9.4$ atm (25 percent higher than the actual strength-hull construction), the coefficient of safety against bulging which was used as a basis was therefore

$$\frac{23.02}{9.4} = 2.45$$

It remains to be investigated whether the scantlings of the frame were the best that could have been chosen. As pointed out above, it should generally be sufficient to strengthen the frame—including a strip of plating of the same width as the flange of the frame—to such a point that its collapsing pressure is 10 percent higher than that of the shell plating. In the present case we should have

$$1.1 p_a = \frac{3 E J}{r^3 l^2} \quad [7.7]$$

therefore

$$J = \frac{1.1 \cdot 23.02 \cdot 40^3 \cdot 23.5}{3 \cdot 2 \cdot 10^6} \quad [7.8]$$

$$J = 6.35 \text{ cm}^4 \quad [7.9]$$

*Annotators' Note: It is to be observed that C. Trilling in U.S. Experimental Model Basin Report 396, "The Influence of Stiffening Rings on the Strength of Thin Cylindrical Shells under External Pressure," February 1935, concluded that formula [5.34] is the correct yield formula and that formula [5.33] should not be used.

Actually, the moment of inertia of the frame is $J' = 23.09 \text{ cm}^4$ and consequently, the frame is more than strong enough and would stand up even if the shell collapsed completely by bulging. It is easy to demonstrate that a reduction in the sectional area of the frame will result in an increase in the collapsing pressure of the shell. If, for instance, we adopt the rule given above, that the frame shall be about 10 percent stronger than the shell, we would, with an angle of $45 \times 30 \times 3.5 \text{ mm}$ obtain a collapsing pressure of 27.1 atm for the plating as compared to 29.6 atm for the frame.

If we compare this result with the strength of the widely-spaced frames of the second tank, we find the following: The stress calculation according to formula [5.33] does not in this case lead to any result; instead, we must use v. Mises' formula [5.35] for collapse by instability. By means of this a collapsing pressure of $p_a = 39.9 \text{ atm}$ is obtained at which the tank would collapse with five bulges. However, it is to be taken into account that at this pressure, stresses of about 2280 kg/cm^2 would occur and that hence the limit of proportionality would be considerably exceeded. The actual collapsing pressure would therefore be lower and by the approximate method developed by v. Mises it will be found to be 37.5 atm. Thus, if the construction principle is followed through to its logical conclusion in the case of the first tank (with a weaker frame), the second tank is stronger than the first by

$$\frac{(37.5 - 27.1) 100}{27.1} = 38.5 \text{ percent}$$

It remains to compare the weights used for the two constructions. The weight per meter run of the first tank is 99 kg while that of the second is 155 kg. Hence, the second tank was heavier than the first by

$$\frac{56}{104} \times 100 = 56.6 \text{ percent}$$

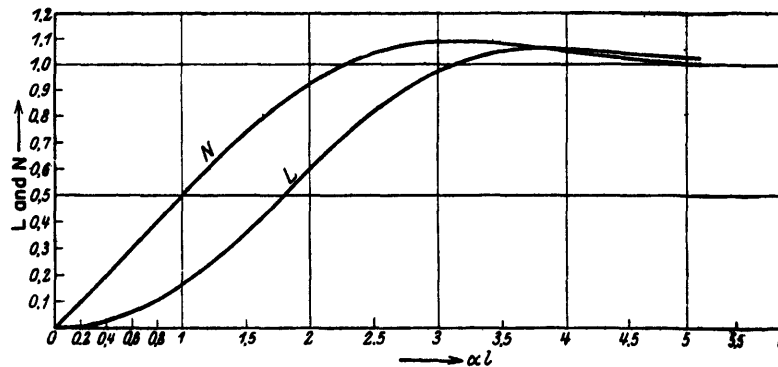

Figure 31 - The Auxiliary Quantities "N" and "L"

TABLE 2

Table for the Auxiliary Quantities L and N
(Compare with Figure 31)

αl in circular measure	αl in degrees	$\text{Sh } \alpha l$	$\sin \alpha l$	$\text{Cof } \alpha l$	$\cos \alpha l$	$\text{Sh } \alpha l - \sin \alpha l$	$\text{Sh } \alpha l + \sin \alpha l$	$\text{Cof } \alpha l - \cos \alpha l$	L	N
0	0	0	0	1	1	0	0	0	0	0
0.2	11° 27.5'	0.2013	0.1986	1.0201	0.9801	0.0027	0.3999	0.0400	0.0068	0.100
0.4	22° 55'	0.4108	0.3894	1.0811	0.9211	0.0214	0.8002	0.1600	0.0268	0.200
0.6	34° 22'	0.6367	0.5645	1.1855	0.8250	0.0722	1.2012	0.3605	0.0601	0.300
0.8	45° 50'	0.8881	0.7173	1.3374	0.6968	0.1708	1.6054	0.6406	0.1065	0.400
1.0	57° 17.4'	1.1752	0.8414	1.5431	0.5404	0.3338	2.0166	1.0027	0.1670	0.500
1.2	68° 48'	1.5095	0.9323	1.8107	0.3633	0.5772	2.4418	1.4474	0.2370	0.596
1.4	80° 12'	1.9043	0.9854	2.1509	0.1702	0.9189	2.8897	1.9807	0.3170	0.689
1.6	91° 40'	2.3756	0.9995	2.5775	-0.0291	1.3761	3.3751	2.6066	0.4080	0.775
1.8	103° 7.4'	2.9422	0.9739	3.1075	-0.2285	1.9683	3.9161	3.3360	0.5050	0.855
2.0	114° 34.8'	3.6269	0.9094	3.7622	-0.4160	2.7175	4.5363	4.1782	0.6000	0.925
2.5	143° 13.2'	6.0502	0.5987	6.1323	-0.8009	5.4515	6.6489	6.9332	0.8220	1.045
3.0	171° 52.2'	10.0179	0.1414	10.0678	-0.9900	9.8765	10.1593	11.0578	0.9770	1.090
3.5	200° 30.6'	16.543	-0.3504	16.5730	-0.9366	16.8934	16.1926	17.5096	1.0500	1.085
4.0	229° 9.6'	27.290	-0.7565	27.3080	-0.6540	28.0465	26.5335	27.9620	1.0580	1.050
4.5	257° 48'	45.003	-0.9774	45.0140	-0.2113	45.9804	44.0256	45.2253	1.0400	1.027
5.0	286° 27'	74.203	-0.9591	74.2100	0.2832	75.1621	73.2439	73.9268	1.0300	1.008

while its strength is only 38.5 percent greater. This example shows clearly that the theory here developed places at the disposal of the designer an excellent tool for determining the scantlings of hollow cylinders with minimum weight. The author attempted to design, on this principle, the strength hull of a submarine cruiser for certain given depths of immersion, i.e., to proportion the thickness of the shell plating, the scantlings of the frames, the frame spacing and at the same time to choose the principal dimensions of the boat in such a manner that the required strength was attained with a minimum weight.

The problem of determining the minimum weight of a strength hull of a given diameter and for given depths of immersion was given an even more general characteristic by the fact that the depth of immersion itself was not assumed from the beginning; instead, it could be chosen as desired within rather wide limits, after the calculation had been completed. If we consider the different variables of the strength-hull construction, viz., the plate thickness s , the sectional area of the frame F (with the flange width b), the frame spacing l' or the unsupported length of plating l respectively, it is seen that when two of these variables are selected, the third is always determined when the collapsing pressure (by instability) of the frame is made a certain function of the collapsing pressure of the shell. In the following we always assume $1.1 p_{k_h} = p_{k_{Sp}}$, where p_{k_h} refers to the shell (Haut) and $p_{k_{Sp}}$ to the frame (Spant). Let us now assume that for a given radius r of the strength hull and a given plate thickness s the collapsing pressure of the shell is plotted against the frame spacing in a system of rectangular coordinates; in that case there will always, to every frame section with a given area F and moment of inertia J , correspond a certain frame space which can be determined in the following manner. For a number of frame spaces and a chosen frame the pressure $p_{k_{Sp}}$ is calculated according to the formula

$$p_{k_{Sp}} = \frac{3 E J}{r^3 l'^2} \quad [7.10]$$

Then for the same frame and for the same frame spaces the pressure p_{k_h} is calculated from the formula [5.33] or [5.35] respectively, and the point of intersection between the curves $p_{k_{Sp}}$ and $1.1 p_{k_h}$ is finally determined. The collapsing pressure p_k which corresponds to the point of intersection gives a point of the curve of the collapsing pressure to be constructed for the plate thickness s . By choosing other frame profiles it is possible to construct as many points on this curve as desired (see Figure 32).

Such a (collapsing pressure) curve can now be constructed for any desired plate thickness. Any line parallel to the axis of abscissas gives then, at its intersection with the curve for the assumed plate thickness, the

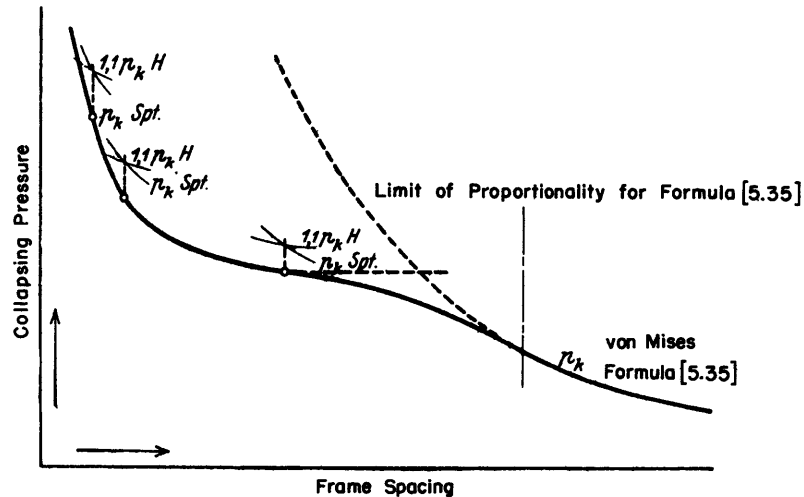

Figure 32 - Collapsing Pressure of a Cylindrical Tube of Constant Shell Thickness and Variable Frame Spacing under a Uniform External Pressure

frame spacing which corresponds to the collapsing pressure and hence to the depth of immersion. It remains now only to calculate the weight of the structure for the various plate thicknesses and to plot them against the frame spacing; thus we obtain a weight curve, the minimum point of which indicates which frame spacing and hence which frame profile should be selected for the prescribed depth of immersion. It remains to be pointed out that by this method of plotting each pressure curve naturally approaches asymptotically a line parallel to the axis of abscissas which is at a distance from the latter corresponding to that value of p_k which would be obtained for an unstiffened tube of infinite length and of plate thickness s .

The method developed here was applied to a strength hull of 6000 mm diameter with a plate thickness varying from 14 to 30 mm. The numerical results of the calculation are represented in the following diagram (see Figure 33) where the curves resulting from the stress and stability calculations are first brought to intersection and then finally connected by a transition curve. This still unexplored transition curve is of course drawn more or less on judgment. However, we shall recognize immediately that this region is without any particular importance for the practical designer; in fact, it is generally best to avoid this region altogether.

In Figure 34 the weight of the strength hull per meter run is plotted for the different plate thicknesses against the frame spacing.* By comparison

*The weight calculation is based on the weights of the shell plating and frames of the strength hull per meter run. Fish plates, rivet heads, etc., were not taken into account since the weight of these parts will not materially affect the results obtained.

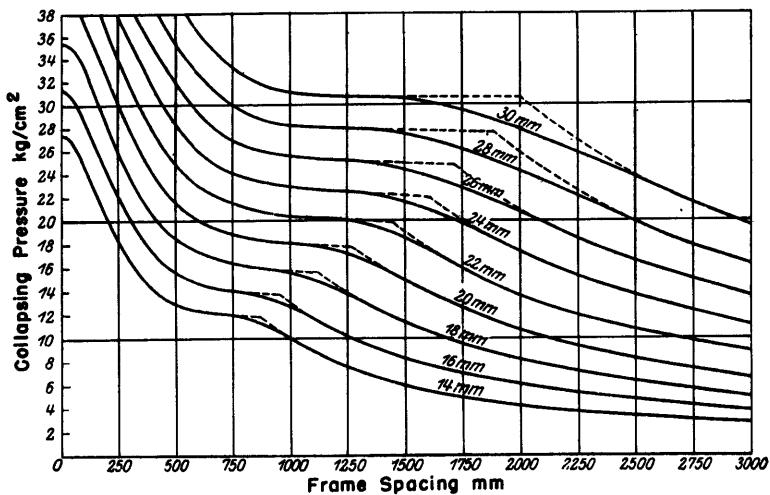

Figure 33 - Strength Hull of 6000 mm Diameter

Curves for collapsing pressure for various plate thicknesses and variable frame spacing.

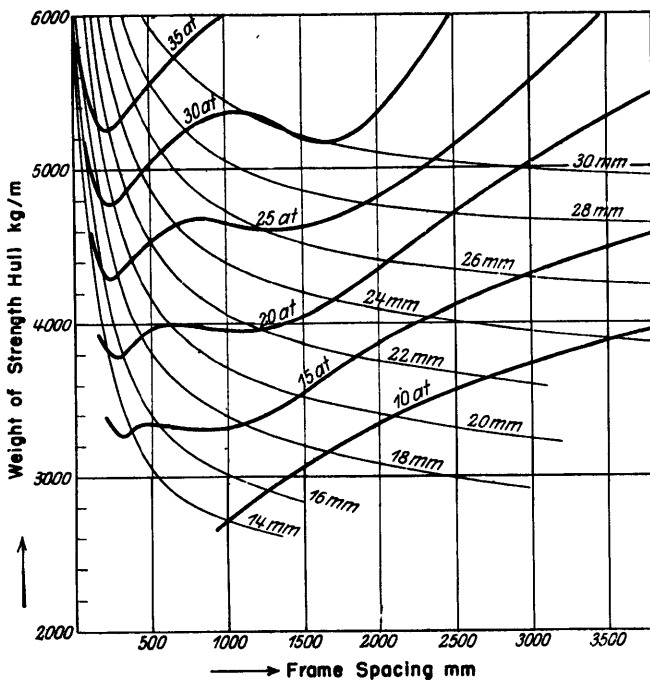

Figure 34 - Strength Hull of 6000 mm Diameter

Curves of weight per unit length for collapsing pressures varying from 10 to 35 atm.

with the curves for the collapsing pressure the weight curves for the various depths of immersion are easily obtained from the curves of Figure 34. The curves have been plotted for pressures of 10, 15, 20, 25, 30, and 35 atm.

Although these curves hold primarily for the special case here investigated, we may nevertheless draw the following general conclusions:

a. The weight curves have two minima, of which the absolute minimum occurs at a very small frame spacing, the other at a frame spacing which in large boats can be adopted in practice.

b. If the frame spacing is increased beyond the second minimum, the weight grows steadily and reaches its maximum in a frameless strength hull.

It is seen that in a strength hull of 6000 mm diameter, the absolute minimum is attained at a frame spacing of about 250 mm. If we consider 500 mm as the smallest frame spacing to be adopted in practice, then, according to the law of similarity, the absolute minimum cannot be realized until the diameter of the strength hull is 12 meters. It is easily seen, however, that the saving in weight which can be realized by going from the upper to the lower minimum is only relatively small,* it is, therefore, desirable to so arrange the design from the beginning that the second minimum is reached. A practically convenient frame spacing is thus obtained. This second minimum can be readily determined mathematically by remaining in the region of the stress calculations. After having found the value of α , the quantity αl is determined in such a manner that the auxiliary quantities L and N referred to above become equal to unity, i.e., by setting αl equal to 5. As soon as the region of transition or even the region of instability is reached, each additional increase in frame spacing is certain to lead to an unnecessary increase in weight. This must be taken into account in the construction of buoyancy tanks especially. These will always be of so small a diameter that it will be possible only in rare cases to reach even the second minimum. For this case we may, therefore, establish the general principle of design that the frame spacing should be made as small as practicable for constructional reasons.

*If, for instance, a depth of immersion of 125 m were taken as a basis and if a double safety were required, the curve for 25 atm would have to be used. The difference between the first and second minima amounts to 4600 - 4300 = 300 kg. In the most extreme case, therefore, in a strength hull of a length of about 80 m, we would save 24 tons, but this advantage would be offset by a rather inconvenient frame arrangement, since the frames would be pierced in numerous places, so that substitute constructions would have to be provided which would largely nullify the relatively small saving in weight.

The example given above shows that by this procedure it is possible to effect a considerable saving in weight as compared with any other mode of construction.

If, in conclusion, we sum up all previous investigations, we find that the theory developed here makes it possible to select for the various depths of immersion the most advantageous dimensions and scantlings for the different members of a strength hull, i.e., to properly proportion the thickness of the shell plating, the profile of the frames, and the frame spacing. Beyond this, however, certain principles of design have been established which make it possible to so dimension the various members of a strength hull for each individual case that the greatest strength is attained with the smallest possible weight which can be adopted in practice.

BIBLIOGRAPHY

1. Boussinesq, J., "Resistance d' un anneau à la flexion," (Resistance of a Ring against Bending), Comptes Rendus, 1883.
2. Burrau, "Tafeln der Funktionen cosinus & sinus mit den natürlichen sowohl reellen als rein imaginären Zahlen als Argument (Kreis & Hyperbelfunkt.) Reimer, Berlin 1907.
3. Föppl, A., "Die wichtigsten Lehren der höheren Elastizitätstheorie," Vol. V, Teubner, Leipzig 1922. (From "Vorlesungen ueber technische Mechanik," 1921-27.)
4. Föppl, A. and L., "Drang und Zwang," Vol. 1-2, R. Oldenbourg, München and Berlin, 1924-28.
5. Gümbel, "Der Einbeulungsdruck kreiszylindrischer Röhren mit Versteifungsringen oder Böden," Schiffbau, Vol. 19, No. 12, 27 March 1918, pp. 225-232.
6. Haigh, B.P., "The Strain-Energy Function and the Elastic Limit," Engineering, Vol. 109, 1920, p. 158.
7. Hamel, "Elementare Mechanik," Teubner, 1912.
8. Hovgaard, W., "Memorandum No. 88 to the Bureau of Construction and Repair," (C & R No. 9563-A27), 20 December 1921.
9. Hurlbrink, E., "Festigkeitsberechnung von röhrenartigen Körpern, die unter äusserem Druck stehen," Schiffbau, Vol. 9, 1907/1908, p. 599-607.
10. Hütte, "Des Ingenieurs Taschenbuch," Vol. I, Edition 22, Berlin 1915.
11. Johow, Hans, "Hilfsbuch für den Schiffbau," 4th edition, J. Springer, Berlin 1920. Neunter Abschnitt, Unterseefahrzeuge.
12. Kármán, Theodor von, "Untersuchungen über Knickfestigkeit," V.D.I., Mitteilungen über Forschungsarbeiten auf dem Gebiete des Ingenieurwesens, Heft 81, 1910.
13. Lamb, H., "Schwingungen elastischer Systeme, insbesondere Akustik," Enzyklopädie der mathematischen Wissenschaften, Vol. 4, Pt. 4, 1907, pp. 215-310.
14. Lorenz, R., "Die Berechnung rotierender Trommeln," Z.V.D.I., Vol. 54, 1910, p. 1397. Supplement by von Sanden, p. 2062.
15. Love-Timpe, "Lehrbuch d. Elastizität," (Elasticity), Teubner, Leipzig 1907.

16. Meyer, E., "Die Berechnung der Durchbiegung von Stäben, deren Material dem Hooke'schen Gesetz nicht folgt," Z.V.D.I., Vol. 52, 1908, p. 167.
17. Mises, R. von, "Der kritische Aussendruck zylindrischer Rohre," Z.V.D.I., Vol. 58, 1914, p. 750.
18. Pietzker, "Die Festigkeit der Schiffe," Berlin 1914.
19. Poeschl, T. and Terzaghi, "Berechnung von Behältern nach neueren analytischen und graphischen Methoden," Berlin 1913.
20. Radiguer, "La Navigation sous-marine," Paris 1911.
21. Runge, Carl, "Über die Formänderung eines zylindrischen Wasserbehälters durch den Wasserdruck," Zeitschr. f. Math. u. Physik, Vol. 51, 1904.
22. Stodola, A. "Die Dampfturbinen," 4th Edition, J. Springer, Berlin 1910.
23. Techel, H., Dr.-Ing., "Der Bau von Unterseebooten auf der Germania-werft," Z.V.D.I., 1919, p. 1302.
24. "University Mathematics for Engineers," Engineering, Vol. 108, 1919, p. 306.

ANNOTATORS' BIBLIOGRAPHY

1. Lévy, M., "Mémoire sur un nouveau cas intégrable du problème de l'élasticité et l'une de ses applications," Journal de math. pures et appl. (Liouville), Ser. 3, Vol. 10, 1884, pp. 5-42.
2. Shanley, F.R., "Inelastic Column Theory," Journal of the Aeronautical Sciences, May 1947.
3. Timoshenko, S., "Theory of Plates and Shells," McGraw-Hill Book Company, New York 1940.
4. Timoshenko, S., "Theory of Elastic Stability," McGraw-Hill Book Company, New York 1936.
5. Trilling, C., "The Influence of Stiffening Rings on the Strength of Thin Cylindrical Shells under External Pressure," EMB Report 396, February 1935.
6. Viterbo, F., "Sul problema della robustezza di cilindri cavi rinforzati trasversalmente sottoposti da ogni parte a pressione esterna," L'Ingegnere, Vol. IV, July 1930, pp. 446-456; August 1930, pp. 531-540.
7. Windenburg, D.R. and Trilling, C., "Collapse by Instability of Thin Cylindrical Shells under External Pressure," EMB Report 385, July 1934.

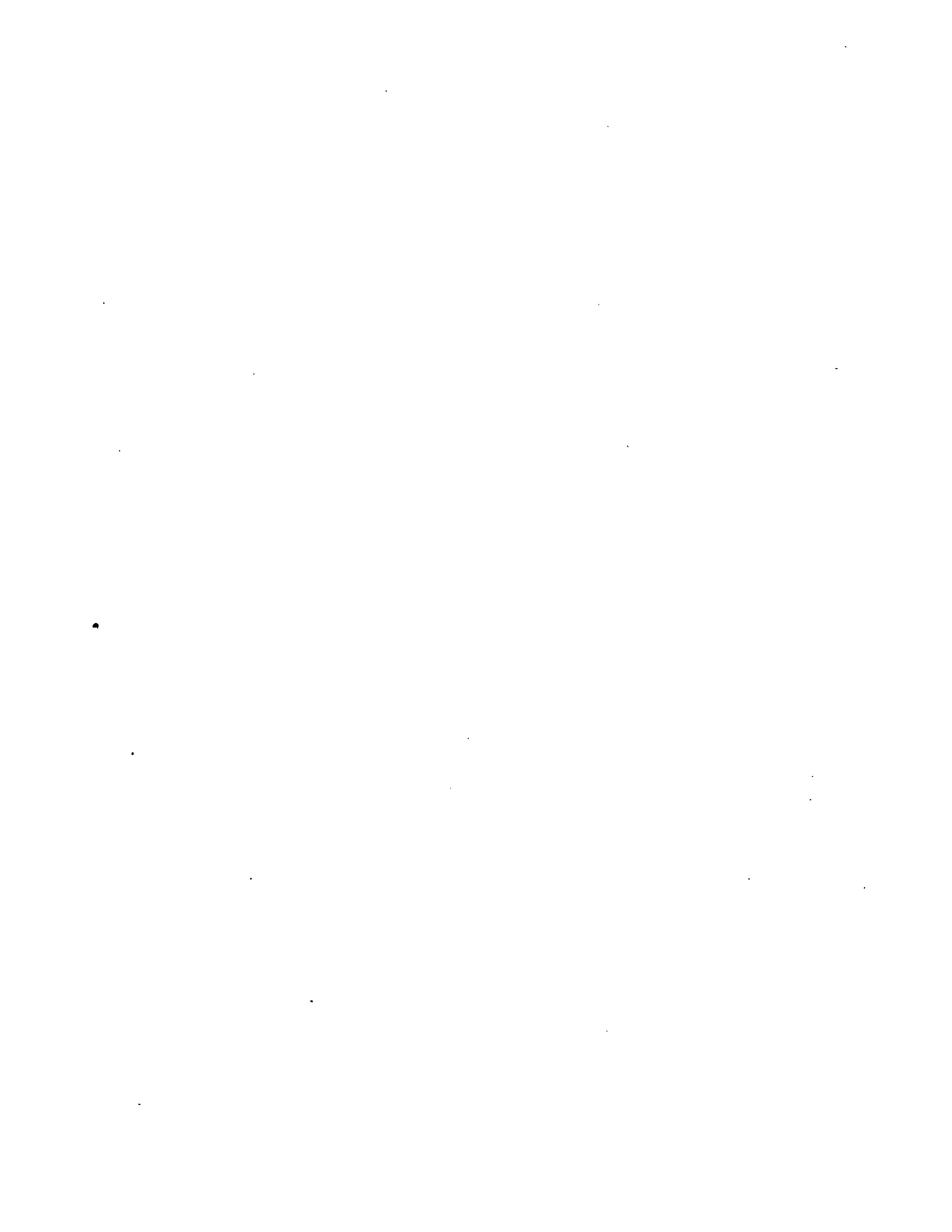

MIT LIBRARIES DUPL

3 9080 02753 1042

MAR 22 1977

AUG 17 1977

MAR 16 1981

~~1861~~

APR 18 1986