

R 761214

Naval Ship Research & Development Center  
Reading Room & Plans File

#2

MIT LIBRARIES



6/2/71

# NAVAL SHIP RESEARCH AND DEVELOPMENT CENTER

Washington, D.C. 20007



V393  
.R46

00	YNC	
01	SKC	
10	GYSGT	
11	YN	
12		

## THE EFFECTS OF SIZE AND ENVIRONMENT ON THE UNIAXIAL COMPRESSIVE BREAKING STRENGTH OF GLASS, ALUMINA, AND PYROCERAM

by

Dionides H. Moreno  
and  
Marcel L. Salive

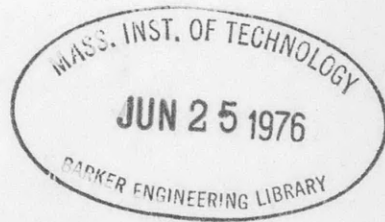

This document has been approved for public  
release and sale; its distribution is unlimited.

DEPARTMENT OF STRUCTURAL MECHANICS  
RESEARCH AND DEVELOPMENT REPORT

May 1970

Report 3315

THE EFFECTS OF SIZE AND ENVIRONMENT ON THE UNIAXIAL COMPRESSIVE BREAKING STRENGTH OF GLASS, ALUMINA, AND PYROCERAM REPORT 3315

The Naval Ship Research and Development Center is a U.S. Navy center for laboratory effort directed at achieving improved sea and air vehicles. It was formed in March 1967 by merging the David Taylor Model Basin at Carderock, Maryland and the Marine Engineering Laboratory (now Naval Ship R & D Laboratory) at Annapolis, Maryland. The Mine Defense Laboratory (now Naval Ship R & D Laboratory) Panama City, Florida became part of the Center in November 1967.

Naval Ship Research and Development Center  
Washington, D.C. 20007

### MAJOR NSRDC ORGANIZATIONAL COMPONENTS

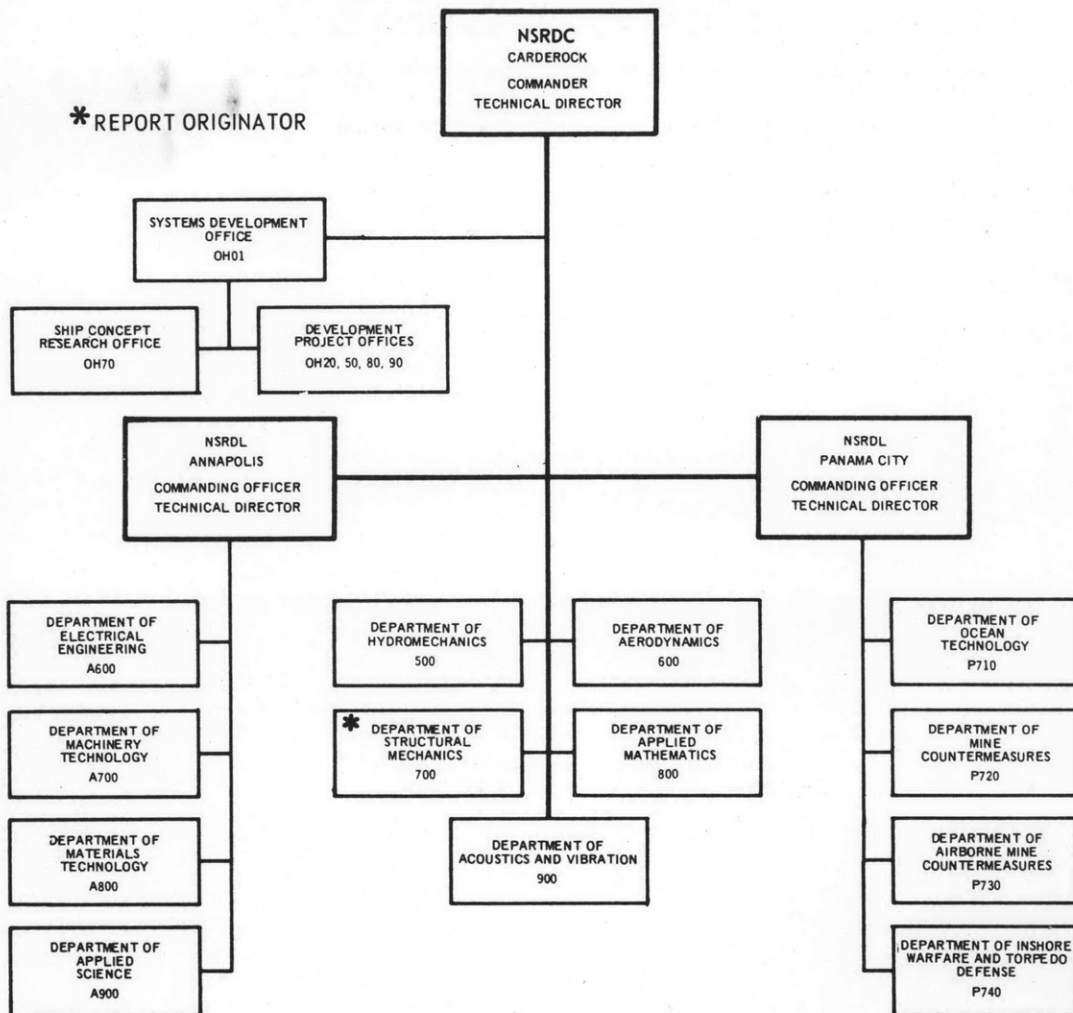

DEPARTMENT OF THE NAVY  
NAVAL SHIP RESEARCH AND DEVELOPMENT CENTER  
WASHINGTON, D. C. 20007

THE EFFECTS OF SIZE AND ENVIRONMENT ON THE  
UNIAXIAL COMPRESSIVE BREAKING STRENGTH  
OF GLASS, ALUMINA, AND PYROCERAM

by

Dionides H. Moreno  
and  
Marcel L. Salive

This document has been approved for public  
release and sale; its distribution is unlimited.

May 1970

Report 3315

# TABLE OF CONTENTS

	Page
ABSTRACT .....	1
ADMINISTRATIVE INFORMATION .....	1
INTRODUCTION .....	1
BACKGROUND .....	1
MATERIALS .....	3
SPECIMENS AND TEST PROCEDURES .....	4
SPECIMENS .....	4
TEST PROCEDURES .....	4
TEST RESULTS .....	6
EFFECT OF SPECIMEN SIZE .....	6
Glass .....	6
Alumina .....	8
Pyroceram .....	8
EFFECT OF ENVIRONMENT .....	8
Glass .....	11
Alumina .....	11
Pyroceram .....	11
EFFECT OF STRESSING RATE .....	11
Loading .....	11
Unloading .....	12
EFFECTS OF STRENGTHENING .....	12
DISCUSSION .....	13
CONCLUSIONS .....	16
APPENDIX – TEST FIXTURES AND TEST PROCEDURES .....	17
REFERENCES .....	43

## LIST OF FIGURES

	Page
Figure 1 – Investigative Steps in a Program to Establish the Compressive Strength of Glasses .....	2
Figure 2 – Nominal Dimensions of Specimens for Uniaxial Compression Test of Glass, Alumina, and Pyroceram .....	5
Figure 3 – Effects of Size and Environment on the Uniaxial Compressive Breaking Strength of Glass, Alumina, and Pyroceram .....	7
Figure 4 – Effect of Specimen Size on the Compressive Breaking Strength of 7265 (50-KSI) Strengthened Glass .....	9
Figure 5 – Effects of Specimen Size on the Compressive Breaking Strength of Annealed AD-99C Alumina .....	9
Figure 6 – Effect of Specimen Size on the Compressive Breaking Strength of 9611 (100-KSI) Strengthened Pyroceram .....	9
Figure 7 – Effect of Specimen Size on the Compressive Breaking Strength of 9606 Annealed Pyroceram .....	10
Figure 8 – Effects of Environment on the Compressive Breaking Strength of 1 1/2-Inch-Diameter Glass Specimens .....	10

## APPENDIX

Figure A1 – Glass Specimens and Gasket Materials .....	20
Figure A2 – Self-Aligning Compression Head and Hardened, Parallel Surface Bearing Blocks .....	20
Figure A3 – Fragment Shields and Precision Alignment Block for Centering Bearing Blocks and Specimen Alignment Jig under Compression Subpress .....	20
Figure A4 – Specimen Alignment Jig and V-Block .....	21
Figure A5 – Specimen Alignment Jig with Specimens and Center Gasket in Place .....	21
Figure A6 – Assembled Specimen Alignment Jig .....	22
Figure A7 – End View of Assembled Specimen Alignment Jig .....	22
Figure A8 – Separable Precision Alignment Blocks and Specimen Alignment Jig under Center of Compression Subpress .....	23

	<b>Page</b>
<b>Figure A9 – Test Setup after Removal of Precision Alignment Blocks and Specimen Alignment Jig .....</b>	<b>23</b>
<b>Figure A10 – Complete Test Setup Showing Compression Subpress, Deflectometer, Spall Shield, Hardened Parallel Bearing Blocks, Gasket Material, and Specimens Centered on the Loading Table of the Testing Machine .....</b>	<b>25</b>
<b>Figure A11 – Setup for Actual Test of Small Specimen .....</b>	<b>25</b>
<b>Figure A12 – Compression Pedestal Head of 600,000-Pound Testing Machine with Self-Aligning Swivel Head .....</b>	<b>27</b>
<b>Figure A13 – Self-Aligning Swivel Loading Head .....</b>	<b>27</b>
<b>Figure A14 – Adaptor Box Around Swivel Head and Three-Piece Steel Frame Attached to the Top Head of the Testing Machine .....</b>	<b>28</b>
<b>Figure A15 – Three-Piece Frame Attached to Top Head of Testing Machine with Alignment Blocks, Hardened Steel Bearing Block, and 18-Percent Nickel Maraging Steel Plate in Position .....</b>	<b>28</b>
<b>Figure A16 – Rubber Drop Cloth Used in Test Setup to Protect Swivel Head and Showing Part of Spall Shield .....</b>	<b>30</b>
<b>Figure A17 – Test Setup before Positioning of Spall Shield .....</b>	<b>30</b>
<b>Figure A18 – Setup for Actual Test of Large Specimen .....</b>	<b>31</b>
<b>Figure A19 – Portion of External Shield around Testing Machine .....</b>	<b>33</b>
<b>Figure A20 – Triple Plastic Bag Filled with Artificial Sea Water .....</b>	<b>33</b>
<b>Figure A21 – Various Items Used in Testing Specimens after Exposure to Artificial Sea Water .....</b>	<b>35</b>
<b>Figure A22 – Setup for Testing Specimens Exposed to Artificial Sea Water .....</b>	<b>36</b>
<b>Figure A23 – Strain-Gaged Specimens and Sintered Tungsten Carbide Bearing Blocks .....</b>	<b>38</b>
<b>Figure A24 – Temperature-Compensating Dummy Gage .....</b>	<b>38</b>
<b>Figure A25 – Strip Chart Recorder, Switch Boxes, and Dummy Gage .....</b>	<b>39</b>

	<b>Page</b>
<b>Figure A26 – Strain-Gaged Specimen Wrapped with Vinyl Tape to Contain Fragments .....</b>	<b>39</b>
<b>Figure A27 – Strain-Gaged Specimens Placed in Section of Fire Hose to Contain Fragments .....</b>	<b>40</b>
<b>Figure A28 – Setup for Testing Strain-Gaged Specimens .....</b>	<b>41</b>
<b>Table 1 – Nominal Characteristics of the Compressive Test Specimens .....</b>	<b>3</b>





## ABSTRACT

The effects of size and environment on the uniaxial compressive breaking strength of glass, alumina, and pyroceram were investigated to establish realistic design criteria applicable to deep-depth hulls and/or buoyancy systems of non-metallic materials. The influence of specimen size (diameters of 1/2, 1, and 1 1/2 in.), test environment (air, atmospheric sea water, and sea water at 10 ksi) and strengthening level (50 and 100 ksi) are discussed and tentative conclusions drawn on the basis of test results for a limited number of specimens. A rather complete description of the test procedures used is included in the Appendix to this report.

## ADMINISTRATIVE INFORMATION

This work was initially authorized and funded using ASBD funds under Subproject SF 013 01 02 Task 0222 and was continued under the sponsorship of the Deep Submergence Systems Project Office, Subproject S4607, Task 11896.

## INTRODUCTION

The Naval Ship Research and Development Center and others have demonstrated the potential of glass and ceramic materials such as alumina and pyroceram as structural hull materials.<sup>1-5</sup>

Prior to testing structural models, the designer requires knowledge of compressive strength of glass and ceramics to calculate the collapse depth of structural submersible hulls. In addition, other data are required for an understanding of the effects of environment, specimen size, and rate of loading on the compressive strength of glasses and ceramics. Therefore, a program was undertaken to establish the compressive strength of glasses; the investigative steps are depicted in Figure 1. The effect of gasketing materials (Phase 4 of Figure 1) is not germane to this report.

It should be understood that the investigative steps outlined in Figure 1 could not be thoroughly studied because of the limited number of specimens available. This report presents and discusses the limited data obtained from the available specimens.

## BACKGROUND

There are no ASTM standard methods for testing the compressive strength of glass and ceramics; in fact, a literature search revealed that each glass producer, researcher, and evaluator has his own in-house testing procedure. The large statistical spread in test results of published data precludes their use for predicting the minimum strength of any given glass.

---

<sup>1</sup>References are listed on page 43.

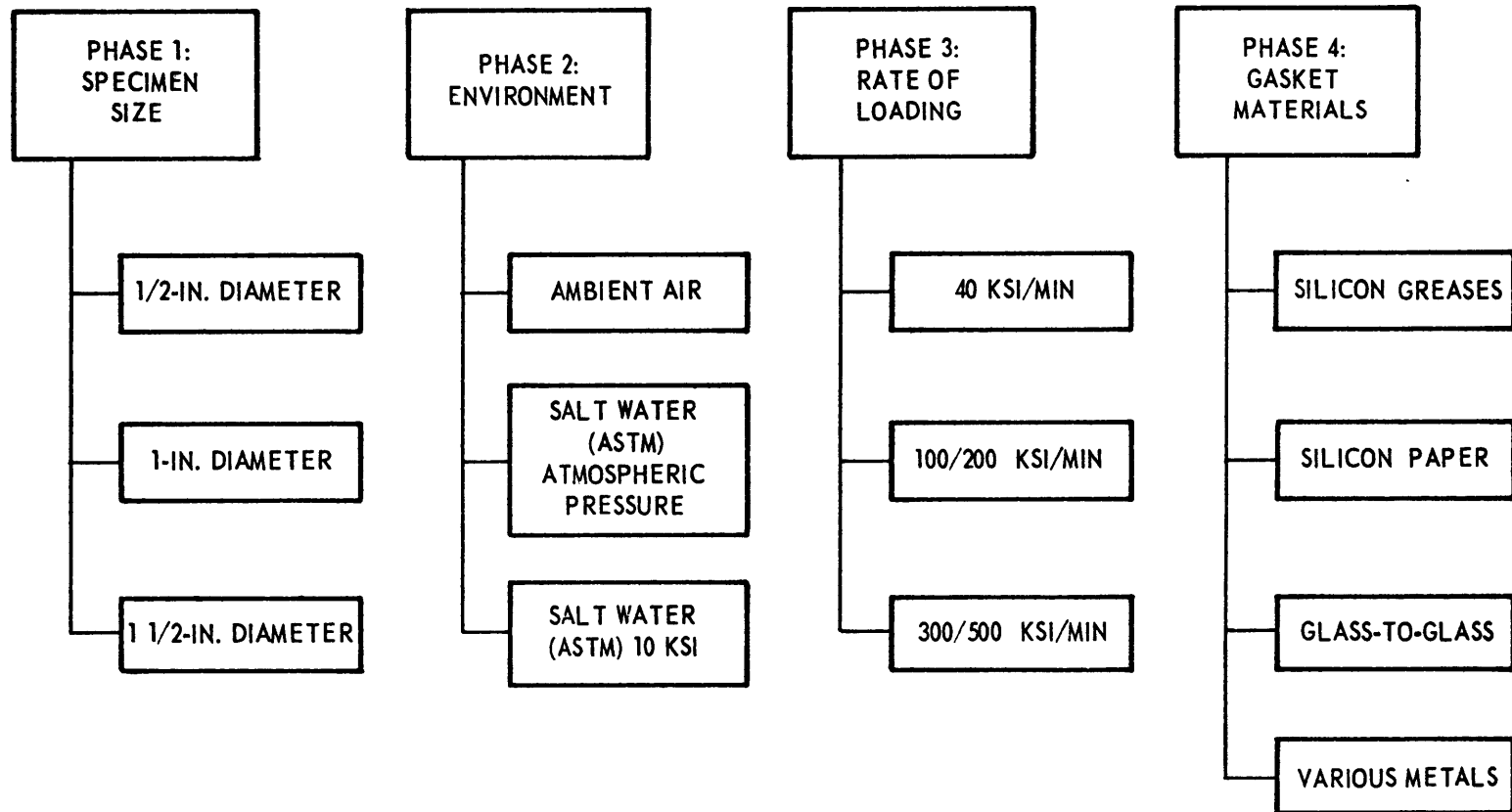

Figure 1 – Investigative Steps in a Program to Establish the Compressive Strength of Glasses

Therefore, in order to establish the compressive strength of glass and ceramics adequate tooling and testing techniques must be developed to obtain statistical data which have a minimum spread and are representative of the glass or ceramics and test conditions being investigated.

In reporting the effects of environment on the static fatigue life of glass, Shand<sup>6</sup> indicates that glass exposed to a humid atmosphere or immersed in water will fail in tension at a lower stress than when held or pulled in a dry or inert gas atmosphere. However, he gives no data on the effects of water in any form on the compressive strength of glass and ceramics. If these materials are going to be considered for use in a deep-diving submersible, the effects of environment on the compressive properties of glass will have to be studied.

## MATERIALS

The materials investigated in the present study included glass, alumina, and pyroceram; they are listed in detail in Table 1 together with information on the general condition of each material, the trade name or trade code number, supplier, and the NSRDC code number used during these tests.

In this investigation, the term "as-annealed" indicates that the material samples had no prestressing due to manufacturing processing; the as-fired alumina samples are also considered to be in the as-annealed condition. The term "as-strengthened condition" indicates

TABLE 1

Nominal Characteristics of the Compressive Test Specimens

Material Type	Material Supplier <sup>(1)</sup>	Trade Code No.	Condition <sup>(2)</sup>	Strengthening Level <sup>(3)</sup> ksi	Nominal Dimensions of Test Specimens in.		No. Specimens Tested	NSRDC Code No.
					Diameter	Length		
Glass	CGW	0311	ANN	-	1 1/2	2 1/4	20	I
	CGW	0312	STR	100	1 1/2	2 1/4	20	II
	CGW	0311	STR	50	1 1/2	2 1/4	20	III
	PPG	7265	STR	50	1 1/2	2 1/4	60	IV-B
	PPG	7265	STR	50	1/2	3/4	50	IV-S
Alumina	CPC	AD-99C	As Fired	-	1	1 1/2	25	VI-B
	CPC	AD-99C	As Fired	-	1/2	3/4	25	VI-S
Pyroceram	CGW	9606	ANN	-	1 1/2	2 1/4	21	V-B
	CGW	9606	ANN	-	1/2	3/4	40	V-S
	CGW	9611	STR	100	1 1/2	2 1/4	20	VII-B
	CGW	9611	STR	100	1/2	3/4	39	VII-S

(1) CGW - Corning Glass Works.  
PPG - Pittsburgh Plate Glass Company.  
CPC - Coors Porcelain Company.

(2) ANN - Annealed condition. No prestressing process.  
STR - Strengthening due to prestressing process.

(3) Strengthening level of the material as reported by the manufacturer.

that immediately after the glass or ceramic specimens were obtained from the basic material, they were strengthened (50 and 100 ksi) by a special prestressing process which put the surfaces of the specimen in compression and the interior in tension. The exact process for prestressing was not available since the manufacturers considered their procedures as proprietary information.

## SPECIMENS AND TEST PROCEDURES

### SPECIMENS

All test specimens were received in the as-ground condition except for several 0311 glass, 0312 glass, and 9611 (100-ksi) strengthened pyroceram specimens which were acid-polished by the manufacturer. Figure 2 depicts the specimen types and sizes, the approximate radius put on both their top and bottom edges, and the grinding grit size used in finishing. All specimens had a length-diameter ratio of 1.50. The radius that was put on both top and bottom edges of the specimens was greater for the glass than for the pyroceram specimens, and it was almost nil for the alumina specimens.

### TEST PROCEDURES

Two separate sets of compression jigs were designed and built. One tooling was adapted for testing all the 1/2-in.-diameter compression specimens using a universal testing machine with a capacity of 200,000-lb. The second compression jig was adapted for testing the 1-in.-diameter alumina compression specimens and the 1 1/2-in.-diameter glass and pyroceram compression specimens using a 600,000-lb capacity universal testing machine. A detailed description of these jigs and the procedure for their use are given in the Appendix of this report.

The two universal testing machines currently being used in this investigation were checked according to the ASTM E4-64 standard, and their accuracies were found to be within  $\pm 1$  percent. Rates of loading\* were as follows:

Loading Rate (lb/sec)	Specimen Diameter (in.)
1000	1 1/2
400	1
100	1/2

The load on the specimen was applied continuously and uniformly until ultimate failure at the particular stressing rate used. The ultimate load and time at which complete fracture of the specimen occurred in each compression test was recorded as breaking load.

The effect of environment was studied by comparing groups of specimens in the following conditions:

---

\*Unless indicated otherwise, the rate of loading was 565 psi/sec (34 ksi/min) for all specimens.

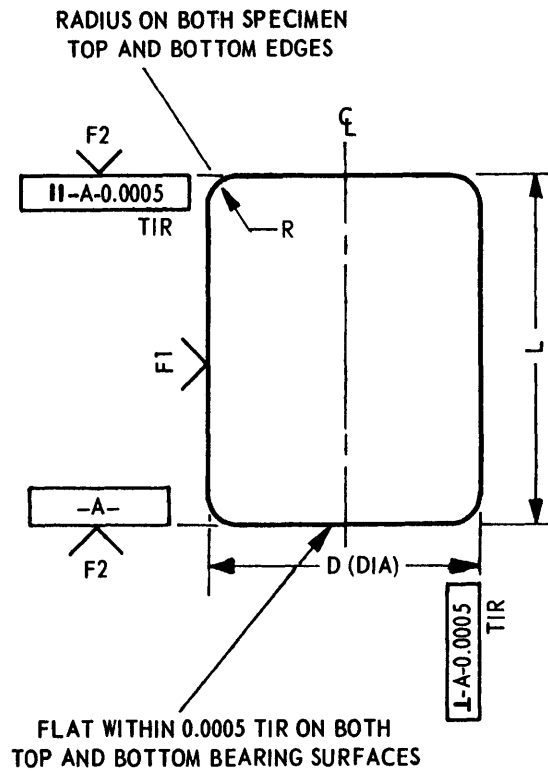

Material	Specimen <sup>(3)</sup> Designation	Specimen Type	Nominal Diameter D in.	Nominal Length L in.	Ratio L/D	Approximate Radius R in.	Grinding Grit Size	
							F1 <sup>(1)</sup>	F2 <sup>(2)</sup>
Glass	Large	A	1 1/2	2 1/4	1.50	5/64	120	280
	Small	C	1/2	3/4	1.50	3/64	120	280
Alumina	Medium	B	1	1 1/2	1.50	1/64	100	220
	Small	C	1/2	3/4	1.50	1/64	100	220
Pyroceram	Large	A	1 1/2	2 1/4	1.50	3/64	120	280
	Small	C	1/2	3/4	1.50	1/32	120	280

(1) Grinding of the lateral surface:  
Carborundum core wheel for glass and pyroceram specimens.  
Carborundum flat wheel for alumina specimens.

(2) Grinding of the bearing end surfaces:  
Diamond flat wheel for all materials.

(3) Specimen designation is according to diameter.

Figure 2 – Nominal Dimensions of Specimens for Uniaxial Compression Test of Glass, Alumina, and Pyroceram

1. In the as-received condition, i.e., no treatment prior to test.
2. Specimens soaked in sea water\* for 2 to 3 weeks at atmospheric pressure before test.
3. Specimens subjected to 10-ksi pressurized sea water for 2 to 3 weeks before test.
4. All specimens that had been exposed to sea water prior to testing were also surrounded with sea water during compression testing.

## TEST RESULTS

Figure 3 depicts the compressive breaking strengths of the glass, alumina, and pyroceram specimens tested to date. Each group of data points of Figure 3 represents only the range of the compressive breaking strengths of a particular material; it does not represent any statistical frequency distribution of the strength values of the specimens. It should also be emphasized that these preliminary results are based on a small number of specimens. The use of the mean strength from any particular group of specimens can be misleading since it is not known whether the frequency distribution of the strengths is Gaussian or skewed; even the minimum values reported herein must be regarded cautiously since the sample size was too small to develop the true minimum strength levels with any degree of statistical assurance.

Nevertheless, the data from Figure 3 provide some interesting highlights. To begin with, if all the specimens tested from each material are considered as a group and the effects of specimen size, environment, and the strengthening level of the material are not separated, then the following general ranges of compressive breaking strengths are observed for the various materials tested:

Material	Strength Range (ksi)
Glass	80-275
Alumina	240-405
Pyroceram	145-387

### EFFECT OF SPECIMEN SIZE

The effect of specimen size was investigated for the three specimen sizes indicated in Table 1 and Figure 1.

#### Glass

The size effect for 7265 (50-ksi) strengthened glass is seen in Figure 4. The compressive breaking strengths of strengthened glass increased with increasing size when the specimens were tested in air. However, when they were tested after soaking in water, the size effect was more what would normally be expected, i.e., the small specimens tended to give higher maximum and minimum values.

---

\*Artificial Sea Water, ASTM Standard D-141-52, Formula C.

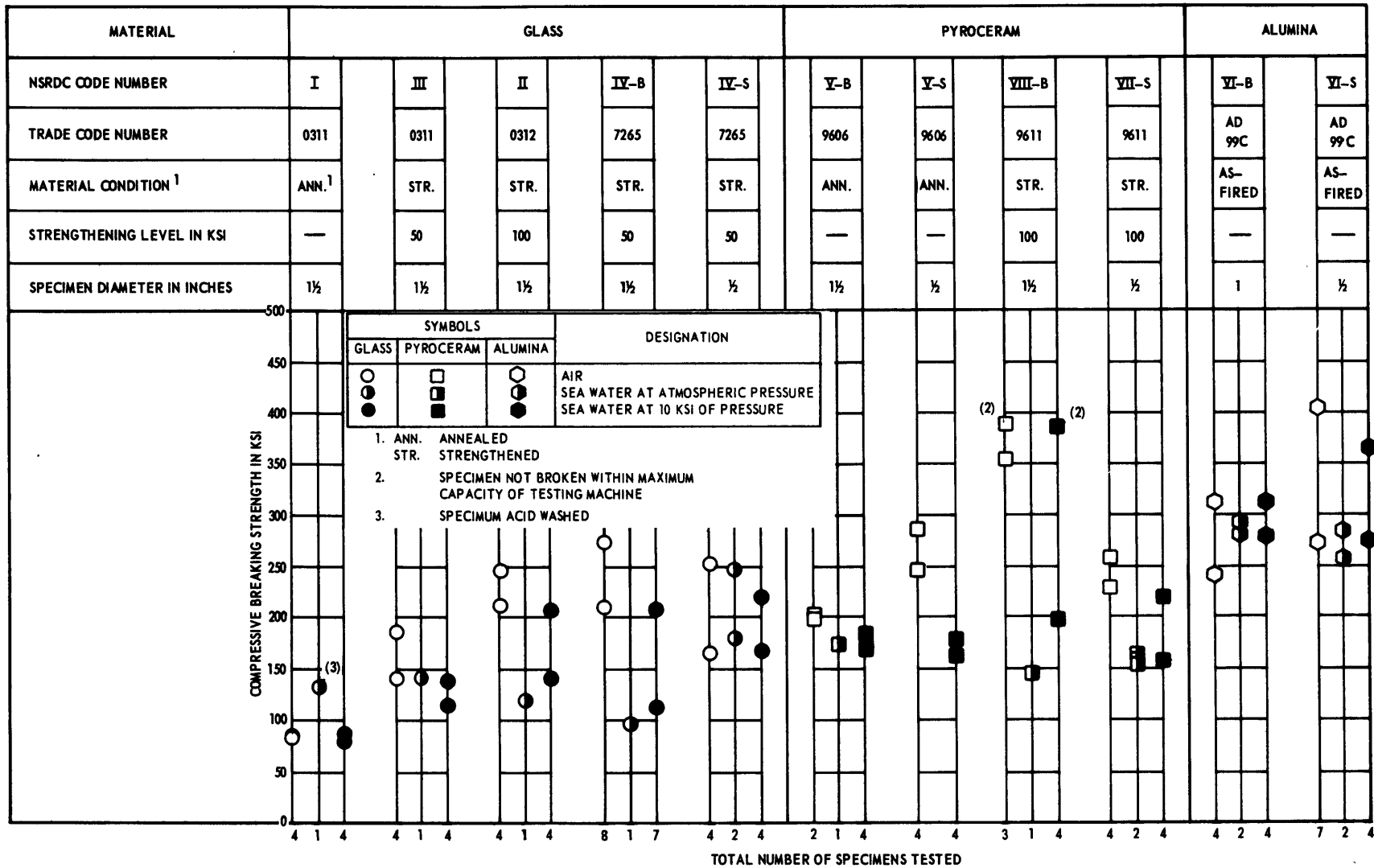

Figure 3 - Effects of Size and Environment on the Uniaxial Compressive Breaking Strength of Glass, Alumina, and Pyroceram

## **Alumina**

The minimum compressive-breaking strengths of the annealed AD-99C alumina increased slightly with decreasing specimen size when tested in air; the maximum observed strength was markedly higher for the smaller size specimens (see Figure 5).

No consistent size effect was observed when the alumina specimens were tested after soaking in sea water. Both the large- and small-diameter specimens gave approximately the same minimum breaking stress (260,000 psi). However, data for the small specimens did tend to show a greater scatter.

## **Pyroceram**

The compressive breaking strength of strengthened 9611 pyroceram increased markedly with increasing specimen size when tested in air; see Figure 6.

The 9611 (100-ksi) strengthened pyroceram again showed a negative size effect (i.e., large size specimens gave higher values) when tested after a treatment of sea water pressurized at 10 ksi. The minimum observed strength for the large specimens, was almost as great as the highest observed strength for the small specimens. On the basis of only three test specimens, it appears that soaking 9611 pyroceram in sea water at atmospheric pressure had very little effect on the compressive breaking strength. The maximum observed strength for the 1 1/2-in.-diameter 9611 pyroceram specimens exceeded the 600,000-lb capacity of the testing machine.

In general, the larger (1 1/2-in.-diameter) strengthened 9611 pyroceram specimens tended to be less sensitive to high pressure sea water soaking than were the smaller specimens even though there was a much greater spread in the data obtained on the larger specimens. This greater sensitivity of the smaller specimens to sea water is probably attributable to their large surface area to volume ratio (8:1 for the small specimens compared to 2 2/3:1 for the large specimens).

The effect of specimen size was markedly different for 9606 annealed pyroceram and strengthened 9611 pyroceram; compare Figures 6 and 7. The large 9606 specimens showed about a 50-ksi loss in strength, whereas the large 9611 specimens tested in air showed a 100-ksi gain in strength when compared to the small specimens. The size effect was not evident for 9606 pyroceram after exposure to sea water at atmospheric or 10-ksi pressure; both large and small specimens had the same minimum compressive breaking stress (approximately 165 ksi).

## **EFFECT OF ENVIRONMENT**

Analysis of the effect of environment was complicated by the simultaneous effects of both specimen size and strengthening level. The following effects on the compressive breaking strength of the materials were observed.



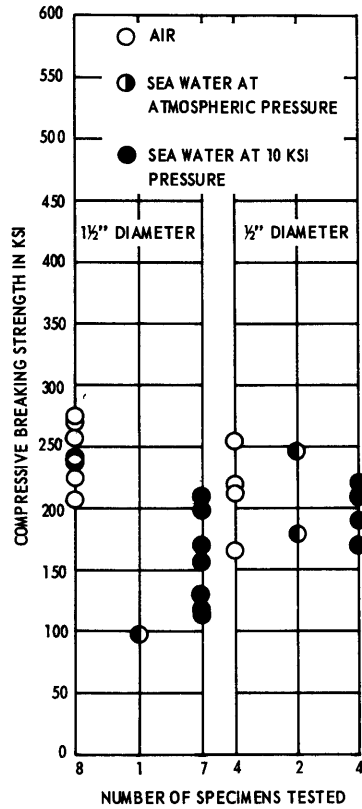

Figure 4 – Effect of Specimen Size on the Compressive Breaking Strength of 7265 (50-KSI) Strengthened Glass

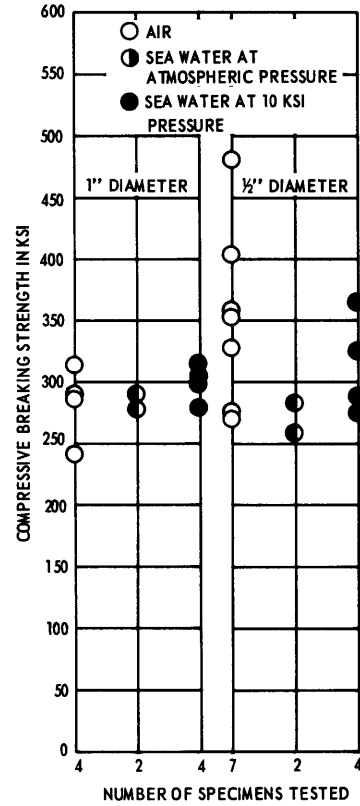

Figure 5 – Effects of Specimen Size on the Compressive Breaking Strength of Annealed AD-99C Alumina

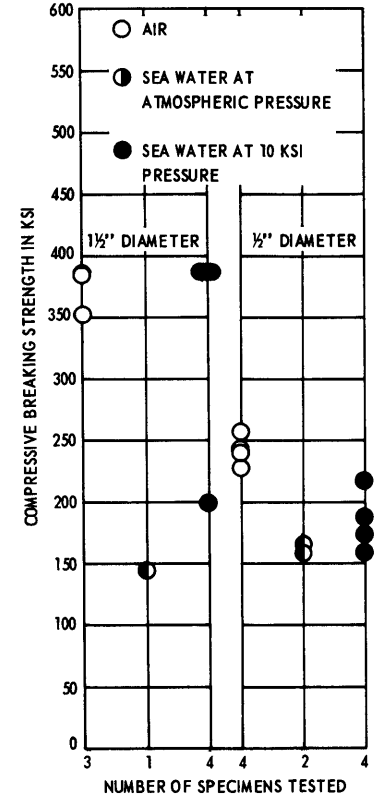

Figure 6 – Effect of Specimen Size on the Compressive Breaking Strength of 9611 (100-KSI) Strengthened Pyroceram

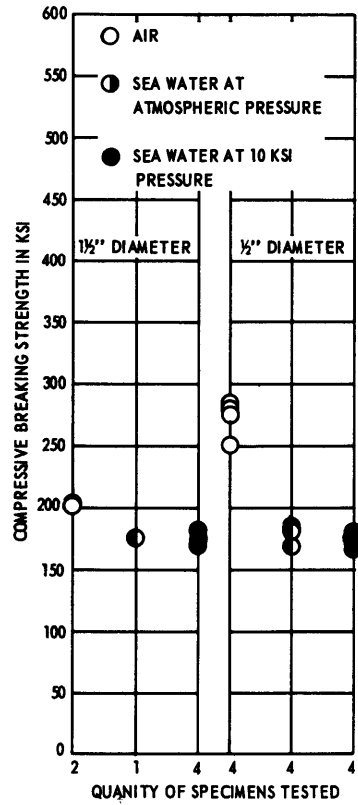

Figure 7 – Effect of Specimen Size on the Compressive Breaking Strength of 9606 Annealed Pyroceram

SYMBOL	DESIGNATION
◇ □ △ ○	AIR
◐ ◑ ◒ ◓	SEA WATER AT ATMOSPHERIC PRESSURE
◔ ◕ ◖ ◗	SEA WATER AT 10 KSI PRESSURE

- GROUP I – GLASS-0311-ANNEALED-1 1/2 IN. DIAMETER
- GROUP II – GLASS-0312-STRENGTHENED (100) – 1 1/2 IN. DIAMETER
- ◇ GROUP III – GLASS-0311-STRENGTHENED (50) – 1 1/2 IN. DIAMETER
- △ GROUP IV-B – GLASS-7265-STRENGTHENED (50) – 1 1/2 IN. DIAMETER

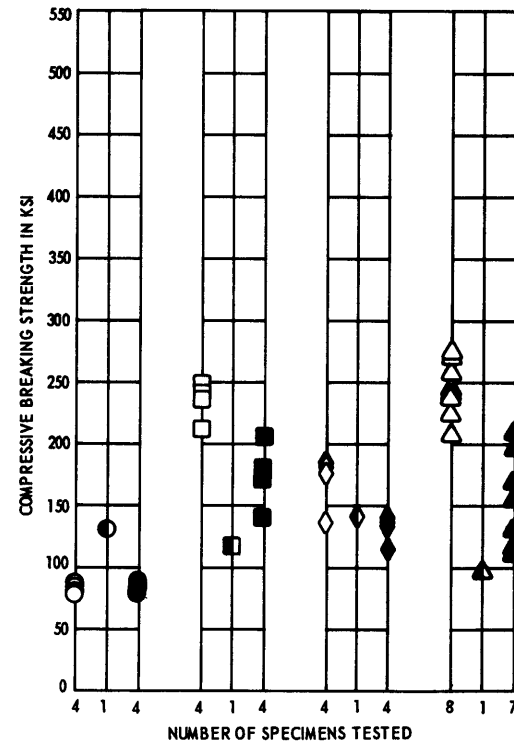

Figure 8 – Effects of Environment on the Compressive Breaking Strength of 1 1/2-Inch-Diameter Glass Specimens

## **Glass**

Environmental effect was negligible for small size specimens of 7265 (50-ksi) strengthened glass. Environment had no apparent effect on large size specimens\* of 0311 annealed glass ( Figure 8); however, it had a detrimental effect on strengthened glass in that the sea water treatments reduced the compressive breaking strength significantly (losses of 20, 100, and 100 ksi for 0311, 0312, and 7265 strengthened glass respectively).

## **Alumina**

There was no environmental effect on alumina regardless of specimen size, despite an apparent tendency for the sea water treatments to slightly reduce the spread between the highest and lowest observed strengths (see Figure 5).

## **Pyroceram**

An environmental effect was readily observable regardless of specimen size; as indicated in Figures 6 and 7, the sea water treatments generally reduced strength. There was a loss of about 75 ksi for both types of small specimens exposed to sea water. However, the effect was not as consistent for the larger specimens. Exposure to sea water resulted in a small loss (about 25 ksi or 12 percent) in the case of annealed 9606 and a larger loss ( 75 ksi or about 21 percent) for the strengthened 9611.

In general, the environmental effect of sea water was the same after exposure at atmospheric or 10-ksi pressure for all material, regardless of both specimen size and strengthening level of the material. The magnitude of the effect did vary with the material and with its strengthening level.

## **EFFECT OF STRESSING RATE**

Two aspects of stressing rate effect should be considered. The first and most common aspect concerns loading the specimen up to failure; the second and less common aspect concerns specimens which have been loaded up to a certain maximum testing stress, have not been broken, and then are unloaded.

### **Loading**

Although the stressing rate effect is frequently not isolated from the effects of size, environment, and the strengthening level of the material, all tests for data of Figure 3 were run at a low stressing rate (approximately 40 ksi/min for large-diameter specimens and 30

---

\*One specimen treated with sea water at atmospheric pressure prior to test had the highest compressive breaking strength; this high value was attributable to an acid wash treatment of the specimen prior to test.

ksi/min for the medium-and small-diameter specimens) and no stressing rate effect was expected to be found. A logical extension of this work would be to include high stressing rates (about 250 and 500 ksi/min) in future tests. Such stressing rates should influence the compressive breaking strength of these materials.

### Unloading

There seems to be a certain critical unloading rate that is dependent on the loading rate. This effect was noticed during the testing of 9611 (100-ksi) strengthened pyroceram. Two specimens broke when unloaded from the 390-ksi testing stress level, one at a rate much higher when unloading than when loading and one at a rate much lower when unloading than when loading. In contrast, three of these specimens did not break when they were unloaded from the 390-ksi testing stress level at an unloading rate close to the initial loading rate.

Since failure is usually associated with tensile stresses, these tests indicate that the tensile stresses induced by the Poisson effect in response to an axial compressive load were of sufficient magnitude to cause failure, in this case even after the principal stress was being reduced. It cannot be determined from the few tests run in this study whether failure is due to (1) the slow growth of a crack to a critical flow size or (2) to a nonuniform relaxation of strain that caused redistribution of tensile stresses to a previously favorably compressively loaded region containing a larger flaw sufficient to cause shattering.

Consequently, it seems that the unstressing or unloading rate used on compression specimens of pyroceram ( and possibly glass and alumina) has some relevant characteristics which are important to state:

1. The unstressing rate may be an inherent variable when unloading a compression specimen from a maximum stress level if safe return of the specimen to a no-load level is desired.
2. Failure of the material on unloading may be sensitive to the unstressing rate; in other words, it seems that a specimen does not fail during unloading if the unstressing or unloading rate matches the stressing rate during loading.

### EFFECTS OF STRENGTHENING

Within the group of glasses, the effect of the strengthening treatment on the overall breaking strength range was of a straightforward pattern ( see also Figure 3):

Glass	Strength Range (ksi)
0311 annealed	80-130
0311 (50-ksi) strengthened	115-185
0312 (100-ksi) strengthened	120-250
7256 (50-ksi) strengthened	100-275

Increased compressive breaking strengths attributable to the strengthening level of the material were also evident for pyroceram which, as can be seen from Figures 6 and 7, varied as follows:

Pyroceram	Strength Range (ksi)
9606 annealed	165-285
9611 (100-ksi) strengthened	145-387

There are signs (see Figure 6) that the 1 1/2-in.-diameter 9611 strengthened pyroceram is so susceptible to environmental effects that the effects of strengthening can be completely masked.

It is readily apparent for all these materials that the compressive breaking strength in air was markedly improved by the strengthening treatment. However, the beneficial effect of the strengthening treatment was not so consistent when the specimens were exposed to sea water. Then the lower bound of the data indicated that the strengthening effects were degraded in some specimens in every group. In effect, this means that after exposure to sea water, the beneficial effects of the strengthening treatment were reduced or in several cases eliminated. This behavior is readily observable in Figure 3; note that after exposure to sea water, the lower bound strength level for a given material was fairly consistent regardless of whether or not the material was strengthened.

## DISCUSSION

As expected, dividing the original small group of specimens to test a large number of variables did not permit fixing definite values to the variables tested, but it did give a rough indication of the significant variables. The variables indicated as significant could be examined in depth by using large groups of specimens and a statistical approach to give quantitative values to their effect.

The effects of specimen size on these brittle nonmetallics is seen by examining Figures 4 through 7. These figures indicate that when tested in air, strengthened 7265 glass and strengthened 9611 pyroceram showed a reverse (or negative) size effect; that is, the larger (1 1/2-in.-diameter) specimens had greater strengths than the smaller (1/2-in.-diameter) specimens. In contrast, the as-fired AD-99C alumina and the annealed pyroceram exhibited normal size effects, with the large specimens having lower values. These results strongly indicate that when the testing is in air, the marked beneficial effect of strengthening obscures any size effects.

Figures 4 through 7 also indicate that the size effect is not so straightforward when the environment is changed from air to sea water. There was no size effect after the as-fired AD-99C alumina, strengthened 9611 pyroceram, and annealed 9606 pyroceram were exposed to sea water at either atmospheric or 10-ksi pressure (Figure 5-7) but, the strengthened 7265 glass did show a normal response to the size effect after exposure to sea water (Figure 4).

After exposure to both atmospheric and 10-ksi sea water, the larger size specimens of 7265 strengthened glass showed markedly low compressive breaking strengths; this is just the opposite of the size effect in air. These figures indicate that the effect of sea water is to mask the effects of size on the compressive breaking stress and to make the strength the same for both size specimens. These figures also indicate that sea water soaking eliminates the beneficial effects of strengthening on the larger size specimens; both sizes of strengthened 9611 Pyroceram specimens had the same strength, and in the case of strengthened 7265 glass, the strengths of the larger specimens was lower.

Recall that the effects of changing environments were studied by testing as-received specimens in air and by testing specimens after soaking in sea water for 2 or 3 weeks at atmospheric and 10-ksi pressure. As discussed earlier, the data indicate that soaking had very little effect on annealed or as-fired specimens but a marked effect on the strength of strengthened specimens.

In many cases, the effect of the pressure at which the soaking occurred was determined by giving only a single specimen the atmospheric pressure soak; four or more were usually soaked at 10-ksi pressure since it was expected that the 10-ksi soak would be more detrimental.

On the basis of the experimental tests performed, it appears that similar results are obtained after soaking at either pressure; the specimens soaked at atmospheric pressure usually fell at or below the lower bound of compressive breaking stress for similar specimens soaked at 10-ksi pressure (see Figure 3).

Although the principal stress in these 9611 Pyroceram specimens was an extremely high uniaxial compressive stress, a significant tensile stress had to develop at right angles to it due to the Poisson effect. In weak areas or in the presence of defects, it is possible that this secondary tensile stress will occasionally be of sufficient magnitude to start a crack in the specimen, and that this crack will continue to grow during unloading. If the flaw grows until it equals the critical flaw size of the material at the tensile stress existing in the specimen at a given moment, the specimen should shatter. On the other hand, if the redistribution of stresses during unloading is erratic, a region containing a large flaw may go from a condition of compressive stress to a condition of tensile stresses and shatter. Such a response should be very erratic because of the complex interaction between the distribution of incipient flaws, flaw sizes, and orientation of the flaws relative to the stress. Because of the small number of tests run in this series of experiments and because of the inherently large scatter in test results observed when testing such extremely brittle materials, it is possible to use the results of these tests only to show that pyroceram will shatter during unloading.

The test data presented herein for strengthened 9611 pyroceram show that the unloading rate might possibly be an important variable and one that must be considered when unloading a compression specimen from high stress levels if a safe return of the specimen to the no-load level is required. If an unloading rate is too high or too low relative to the initial

loading rate of these brittle high strength materials, it may cause the specimen-or possibly even a structure- to break during unloading. The effects of unloading rate on the failure of pyroceram warrant further investigation (1) to pin down the rate limit effects (2) to determine whether this effect is present in other materials as well, and (3) to determine whether the effect is due to either crack growth during unloading or an unfavorable redistribution of stresses.

The effect of a "strengthening" treatment is to increase the compressive breaking strength of the materials tested in air and to mask or eliminate any size effects. Although the strengthening treatment is beneficial for specimens tested in air, exposure to sea water markedly reduces or even eliminates the beneficial effects of strengthening. In fact, Figure 3 shows that exposure to sea water reduced the lower bound of the compressive breaking strength of the strengthened specimens down to about the lower bound of the unstrengthened specimens.

Comparison of the effects of environment on different size specimens is difficult since only three groups of 1/2-in.-diameter specimens were tested, one each of glass, pyroceram, and alumina. However, some observations can be made. Sea water soaking had little or no effect on the small 1/2-in.-diameter specimens of strengthened 7265 glass, but it had a noticeable effect on the compressive breaking strength of the larger 1 1/2-in.-diameter specimen. An opposite response to salt water soaking was found for the annealed 9606 pyroceram and the as-fired AD-99C alumina; these two materials showed a marked reduction in compressive breaking strength for small (1/2-in.-diameter) specimens and little, if any, effect for the larger specimens (1 1/2 in. diameter).

It would appear that the effect of specimen size and exposure to sea water is related both to the specimen size and to whether or not a material is in the annealed condition. Small annealed or as-fired specimens were detrimentally affected by sea water whereas larger annealed specimens were not. Conversely, the large strengthened specimens were more affected by sea water than were the small specimens.

Results of tests of the strength of brittle nonmetallics typically exhibit large scatter. This was so for the present case, and some of the values were rather high. Although high strength values reported herein cannot be used for design purposes, they do give an indication of the magnitude of the strength that may possibly be attained if the producer can control his processing variables or develop a new production technique that keeps flaw sizes to a minimum. Until the producers demonstrate the ability to consistently produce glass with the high strength currently demonstrated by only an occasional specimen, the designer must content himself with using a more conservative value that will be indicative, say, of perhaps the lower bound of the values that might reasonably be encountered.

## CONCLUSIONS

The following tentative conclusions can be made on the basis of these results for a limited number of test specimens representing a variety of materials (glass, pyroceram, and alumina), specimen sizes (1/2-, 1-, and 1 1/2-in. diameters) and test conditions (air, after atmospheric sea water soak, and after a 10-ksi pressurized sea water soak).

1. The compressive breaking strength of alumina was greater than that of pyroceram, and pyroceram was stronger than glass.
2. The compressive breaking strength of large (1-in. diameter) alumina specimens was unaffected by sea water.
3. The compressive breaking strength of glass and pyroceram was markedly improved by a strengthening treatment provided the material was not subsequently exposed to sea water.
4. Strengthening treatments improved the strength more for larger than for smaller size specimens of glass and pyroceram.
5. For unstrengthened glass and for as-fired alumina, smaller specimens tended to indicate higher breaking strengths.
6. Soaking in sea water tended to minimize or eliminate the beneficial effects of strengthening.
7. The effect of exposure to sea water was negligible for annealed and as-fired materials but was pronounced for the strengthened materials, which may lose 20 to 100 ksi in minimum compressive breaking strength.
8. Soaking glass, alumina, and pyroceram was just as detrimental at atmospheric pressure as when done at 10-ksi pressure.
9. Failure of a material (in this case, 100-ksi strengthened pyroceram) is possible during unloading from some high compressive stress level.
10. It appears that unloading a material (in this case 100-ksi strengthened pyroceram) from some high level of compressive stress will not cause failure if the unloading rate matches the original loading rate.



**APPENDIX**  
**TEST FIXTURES AND PROCEDURES**

	<b>Page</b>
<b>INTRODUCTION</b> .....	<b>18</b>
<b>JIGS AND PROCEDURES FOR SMALL SPECIMENS</b> .....	<b>18</b>
<b>JIGS AND PROCEDURES FOR LARGE SPECIMENS</b> .....	<b>24</b>
<b>METHODS FOR EXPOSING SPECIMENS TO ARTIFICIAL SEA WATER</b> .....	<b>29</b>
<b>PROCEDURES FOR STRAIN-GAGED SPECIMENS</b> .....	<b>34</b>
<b>SUMMARY</b> .....	<b>37</b>
<b>Test Specimens</b> .....	<b>37</b>
<b>Test Procedures</b> .....	<b>42</b>

# APPENDIX

## TEST FIXTURES AND PROCEDURES

### INTRODUCTION

Two separate sets of compression jigs were designed and built. One set of tooling was adapted for testing all the 1/2-in.-diameter compression specimens using a universal testing machine with a capacity of 200,000 lb. The second compression jig was adapted for testing the 1-in.-diameter alumina compression specimens and the 1 1/2-in.-diameter glass and pyroceram compression specimens using a 600,000-lb capacity universal testing machine.

A check of the two universal testing machines according to ASTM standard E4-64 indicated that their accuracies were within  $\pm 1$  percent. Rates of loading\* were as follows:

Loading Rate (lb/sec)	Specimen Diameter (in.)
1000	1 1/2
400	1
100	1/2

The load on the specimen was applied continuously and uniformly until ultimate failure at the particular stressing rate used. The ultimate load and time at which complete fracture of the specimen occurred in each compression test was recorded as breaking load.

### JIGS AND PROCEDURES FOR SMALL SPECIMENS

Figures A1–A11 clearly and accurately depict the jigs and procedures used to consistently ensure precise alignment of the specimens, bearing blocks, and subpress. In addition, they show the installation of spall shields around the specimens and fixtures to prevent injury to test personnel and to prevent the deflectometer and subpress slides being jammed with the fine glass fragments that are produced with explosive violence when the glass specimens fail. The figures are presented in the sequence one would follow in running a test.

Figure A1 shows some of the small size glass specimens and some of the materials that were used as gasket (or bearing) materials. In addition, a silicon grease (Dow Corning Compound 4) or Lubriplate was used to lubricate the ends of the specimens and so minimize end effects. The specimens were all made with the ends parallel to each other and perpendicular to the axis of the specimen within very close tolerances. However these small specimens were not exactly round and therefore were hard to align; some were lobed and some were oval in cross section.

Figure A2 shows a self-aligning compression head used in some of these tests and some of the hardened, S5 tool steel, parallel surface bearing blocks. These blocks were hardened to Rockwell C 60/63. The ends were ground parallel within 0.0005 in. and had a No. 8

---

\*Unless indicated otherwise, the rate of loading was 565 psi/sec (34 ksi/min) for all specimens.

finish on the bearing surfaces. The spherical seat in the self-aligning head was coated with a mixture of Lubriplate grease and molybdenum disulfide which had been found particularly effective for this purpose; this head was to ensure an axial load would be applied to the full end face of the test specimens and of the compression subpress shaft. The hardened tool steel blocks were carefully prepared with smooth parallel surfaces; they were used to prevent the glass specimens from indenting the surfaces of the subpress (this would be very difficult to repair) and to prevent the glass fragments produced at fracture from sandblasting these surfaces. This brinelling and scratching made it necessary to refinish these blocks after almost every test.

Figure A3 shows the separable aluminum alignment blocks used to precisely align the steel bearing blocks and the nylon specimen alignment jig under the exact center of the compression subpress loading shaft. The inner surface of the vertical arm of the subpress frame was machined and ground for use as a permanent mating reference surface for use with the long narrow flat face of the alignment blocks; the width of this assembly was made the same as the width of bearing face on the bottom of the subpress to give the second surface required for precise alignment. This figure also shows the separable Lucite fragment shield that is subsequently put around the test setup in the subpress after all the alignment jigs and fixtures are removed. A flexible doughnut-shaped piece of plastic is fitted around the upper hardened bearing block to close off the top of the fragment shield and prevent fragments from rebounding off the walls and out the top of the shield; this is just one example of the many possible ways to close this area.

The specimen alignment jig and the machinist's V-block on which it is set during assembly are also shown in Figure A4; the jig is made of nylon so as not to damage the specimen. It should be noted that since the one side of the alignment jig is made in one piece, the use of the V-block as shown in Figure A4 is a matter of convenience rather than an absolute necessity during preparation of the test setup. Figure A5 shows the unassembled jig and Figures A6 and A7 the assembled jig. Note in Figure A7 the soft rubber tips used on the ends of the set screws (1) to prevent damage when the glass specimens are pushed against the side of alignment jig and (2) to keep the specimen from sliding out of the jig. Even with such a fixture like this one, to axially align two specimens, small irregularities in specimen cross section or chips out of the edge of the end surface will contribute markedly to the observed variance in test results.

Figure A8 shows the separable precision alignment blocks used to align the bearing blocks and the specimen alignment jig under the exact center of the compression subpress. Note that the back of the alignment block is in contact with the reference plane machined on the vertical arm of the compression subpress and the bottom surface of the jig is centered on the bearing face of the base of the subpress.

Figure A9 shows the same setup after removal of the various alignment fixtures; a small preload was applied to the test setup to prevent movement during the removal of these

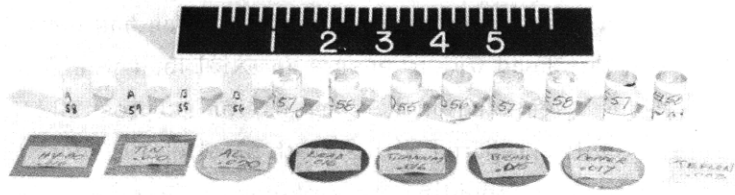

PSD 314658

Figure A1 – Glass Specimens and Gasket Materials

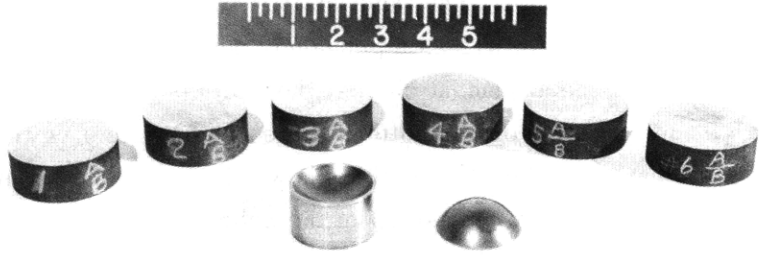

PSD 314659

Figure A2 – Self-aligning Compression Head and Hardened, Parallel Surface Bearing Blocks

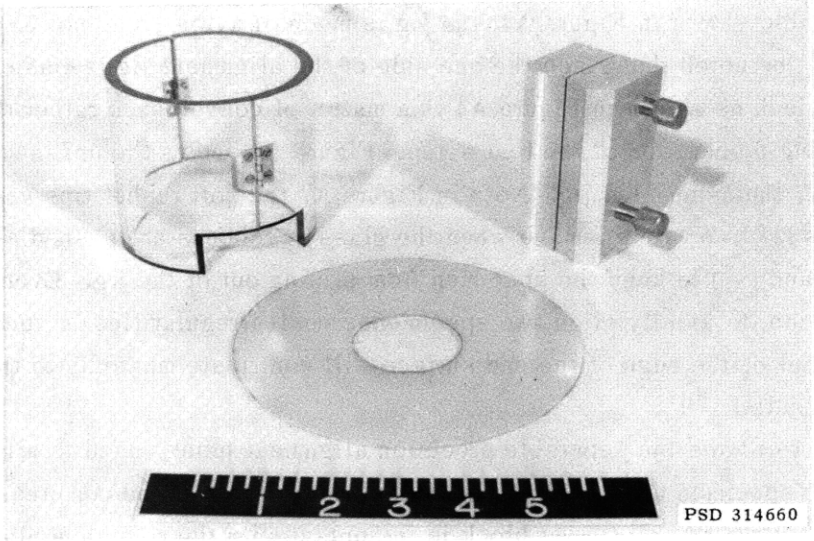

PSD 314660

Figure A3 – Fragment Shields and Precision Alignment Block for Centering Bearing Blocks and Specimen Alignment Jig under Compression Subpress

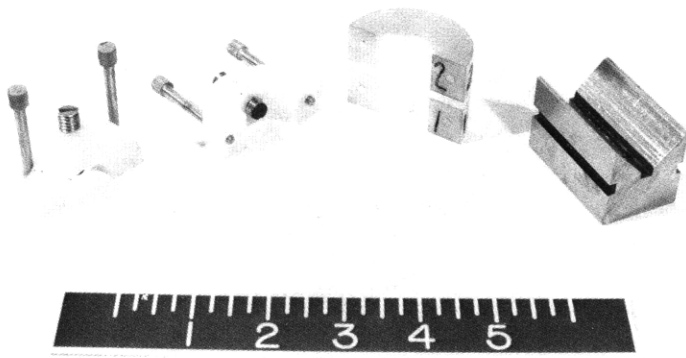

PSD 314661

Figure A4 – Specimen Alignment Jig and V-Block

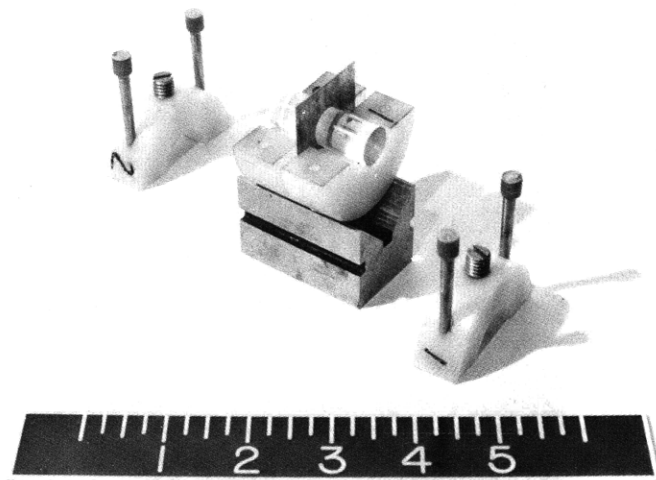

PSD 314662

Figure A5 – Specimen Alignment Jig with Specimens and Center Gasket in Place

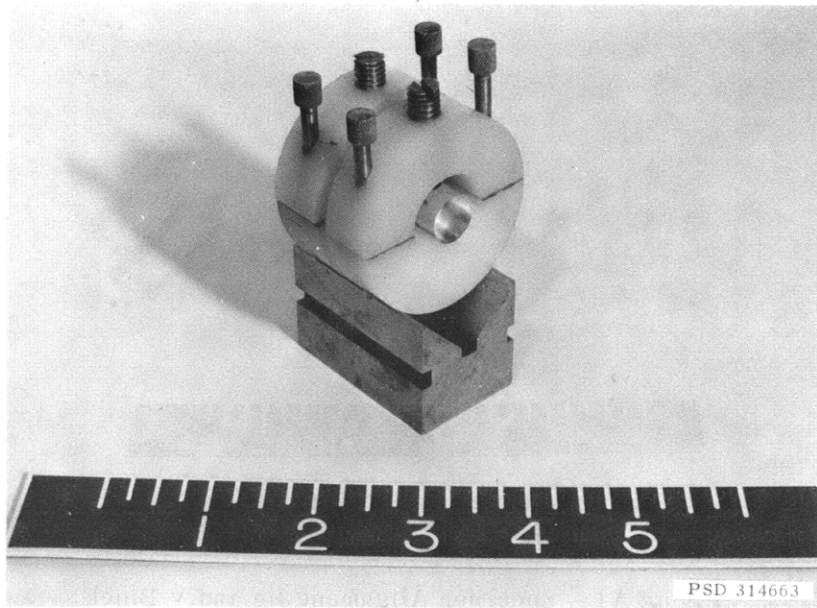

Figure A6 – Assembled Specimen Alignment Jig

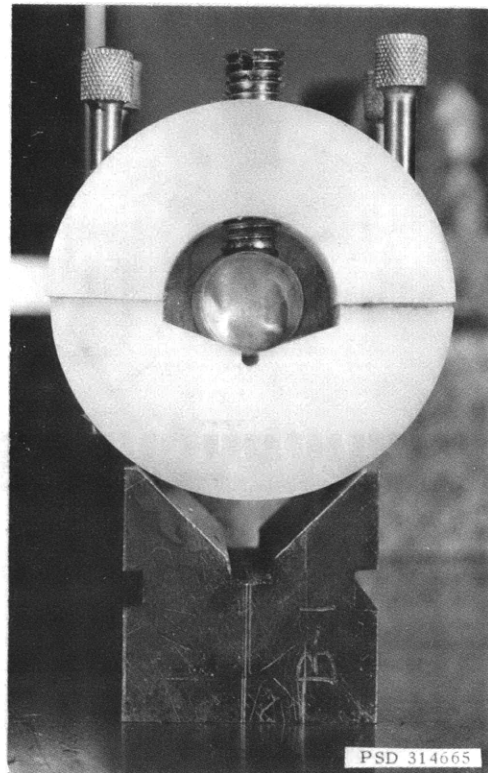

Figure A7 – End View of Assembled Specimen Alignment Jig

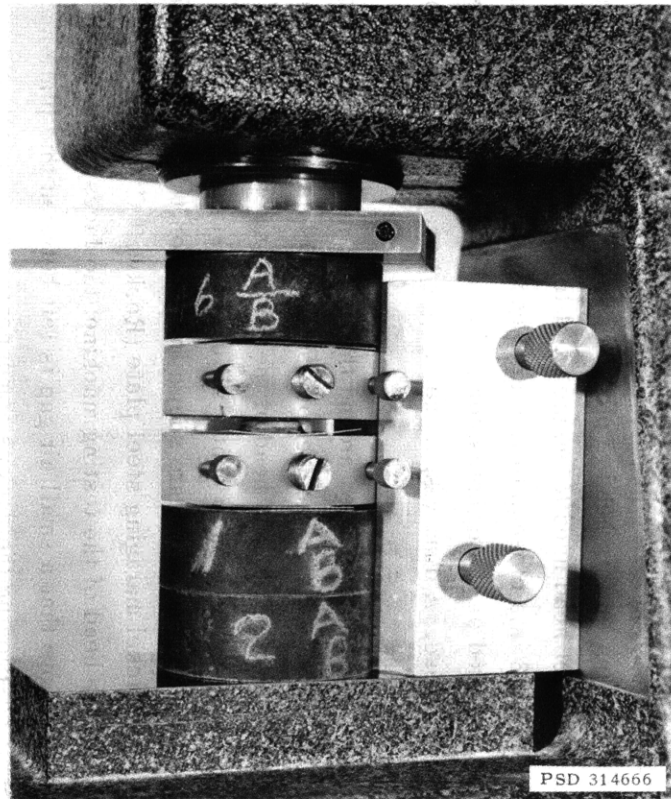

Figure A8 – Separable Precision Alignment Blocks and Specimen Alignment Jig under Center of Compression Subpress

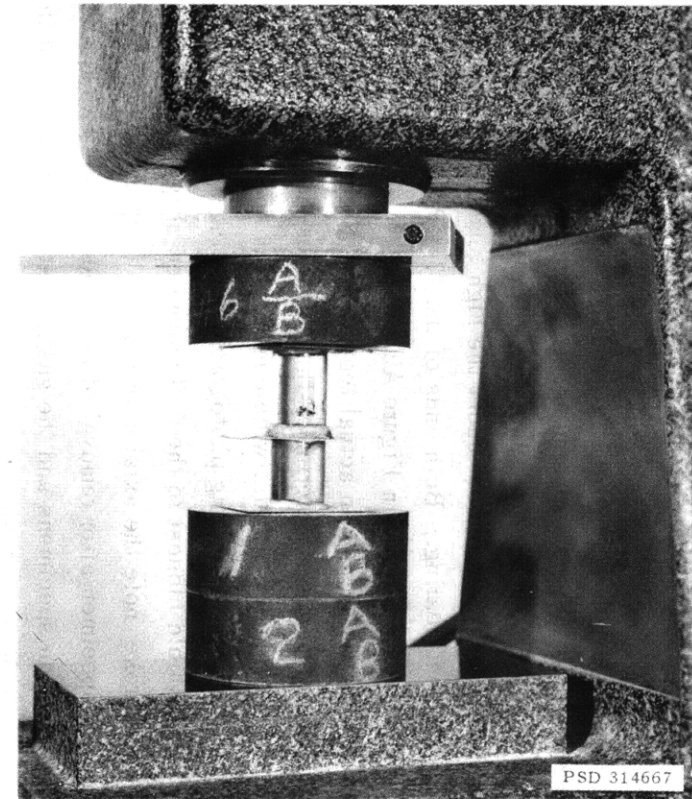

Figure A9 – Test Setup after Removal of Precision Alignment Blocks and Specimen Alignment Jig

items. Also note the appearance of the lubricating grease at the ends of the specimen halves adjacent to the gasket material; this was an aspect of the test being photographed since some tests were run either without the grease or only with the grease.

Figure A10 shows the complete test setup prior to testing. Because of the high loads encountered in testing some of the glass specimens, it was necessary to substitute a hardened 17-4 PH steel shaft in the compression subpress. (The softer steel shaft originally provided with the standard subpress barreled out under the high loads encountered in these tests and got caught in its alignment bearing.) Both ends of the 17-4 PH shaft were provided with self-aligning heads similar to that shown in Figure A2.

Figure 11 shows the setup during an actual test. Note (Figure A11a) the cupping of the gasket material due to extrusion of material by the high pressures encountered during the test. The spall shield was placed on 1/2-in.-wide compression specimens to raise it to a convenient height. In this and the following photograph, masking tape was used to cover the seam in the fragment spall shield closest to the deflectometer. Figure A11b shows the same setup after the specimens broke; note the axial nature of the fracture planes. Figure A11c is a closeup of the broken specimen after removal of the upper bearing block, and Figure A11d shows the details of the broken specimens and the gasket material used during this test. Again note the long columnar nature of the broken glass fragments.

## **JIGS AND PROCEDURES FOR LARGE SPECIMENS**

Figure A12 shows the compression pedestal head of the 600,000-lb testing machine. A thick steel baseplate was put on this head to provide a larger working surface, and on it was placed the self-aligning swivel head used to ensure axial loading across the entire surface of the specimens. Figure A13 is a closeup of the large capacity self-aligning swivel head. The alignment plate is centered on the compression pedestal head and is permanently bolted to the self-aligning swivel head. A dummy specimen is positioned in the center of the swivel head.

Figure A14 shows a wooden box used around the swivel head, to build up to the level of its top. The box supports the rubber sheet employed to keep glass out of the swivel joint. A three-piece steel frame bolted to the top head of the testing machine (shown at the top of Figure A14) is the indexing device used to center all of the test components. Two alignment blocks and a hardened steel bearing block are shown in place on this frame. As indicated in Figure A15, an 18 percent nickel maraging steel plate (Rockwell C 40/43) goes between the hardened steel block and the head of the testing machine; the faces of this plate are ground parallel within 0.0005 in. Note that a small air gap is left between this plate and the head of the machine to permit positioning the various components; this gap will close when the specimen picks up these upper components at the start of the loading cycle. The alignment



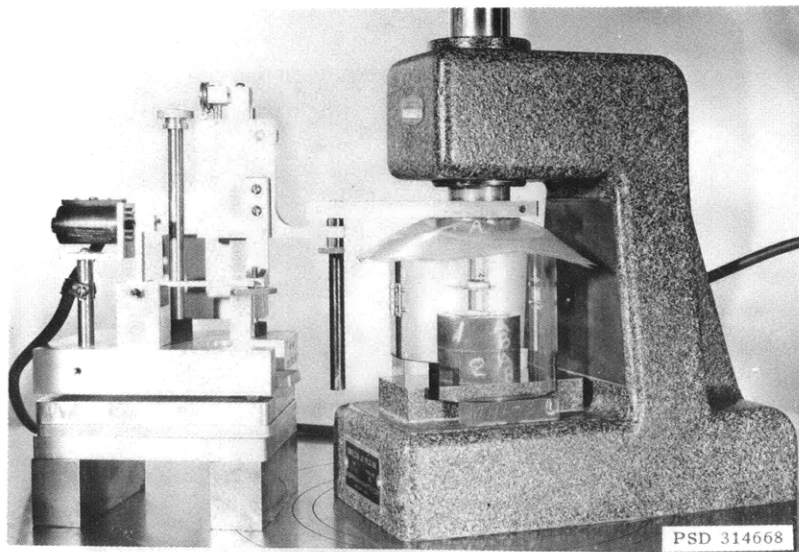

Figure A10 – Complete Test Setup Showing Compression Subpress, Deflectometer, Spall Shield, Hardened Parallel Bearing Blocks, Gasket Material, and Specimens Centered on the Loading Table of the Testing Machine

Figure A11 – Setup for an Actual Test of Small Specimen

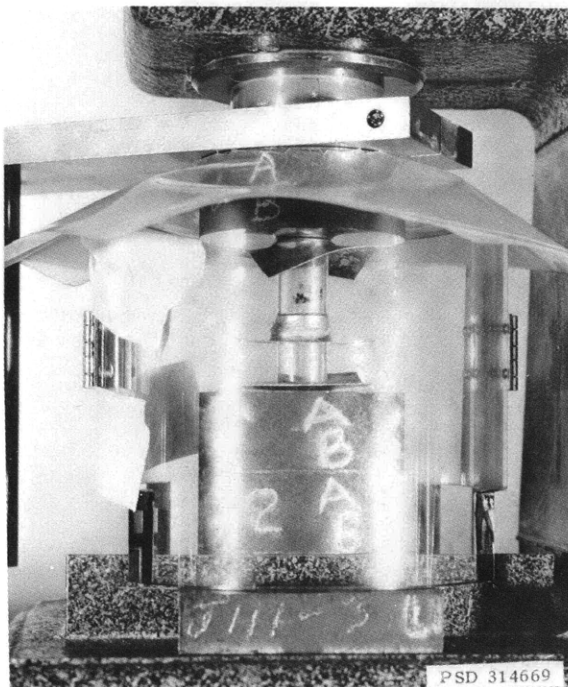

Figure A11a – Cupping of Gasket Material Due to Extrusion of Material during Test



Figure A11b – Same View as in Figure 11 after Specimen Broke



Figure A11c – Broken Specimens after Removal of Upper Bearing Block

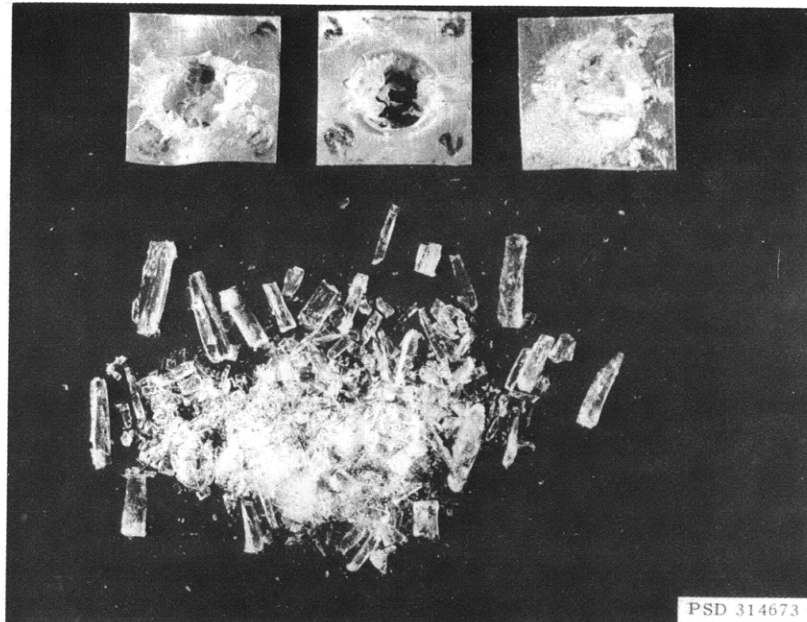

Figure A11d – Details of Broken Specimens and Gaskets

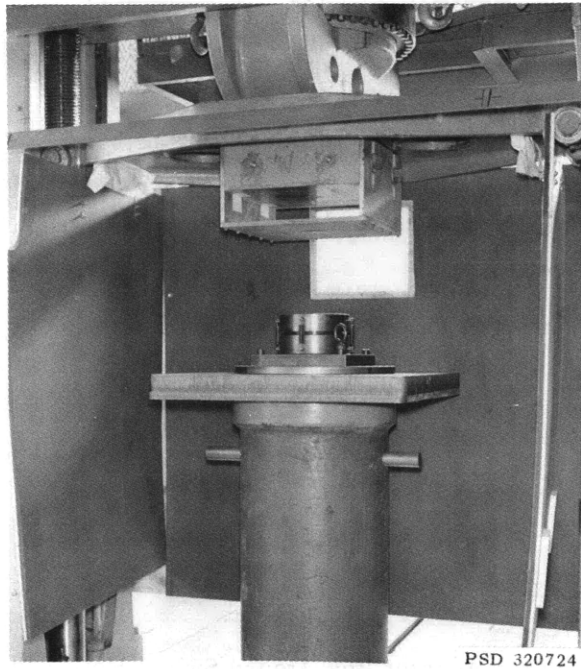

Figure A12 – Compression Pedestal Head  
of 600,000-Pound Testing Machine with  
Self-Aligning Swivel Head

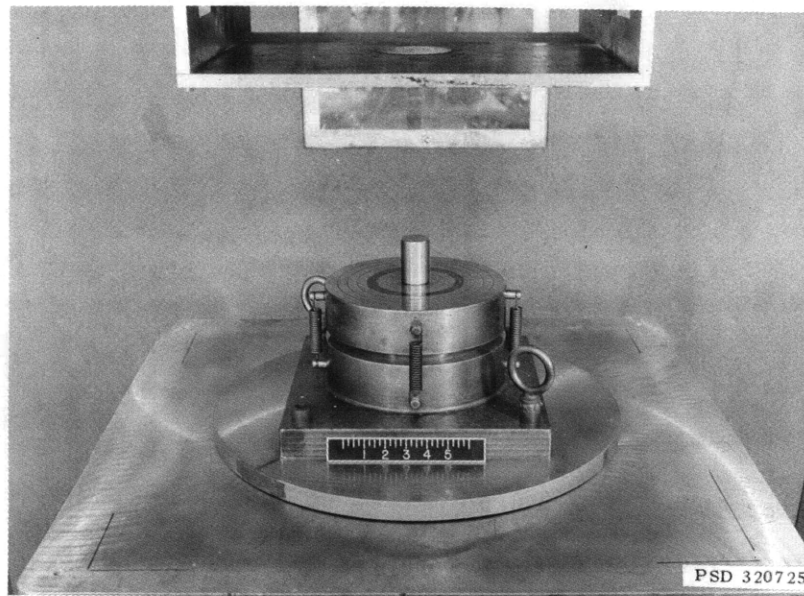

Figure A13 – Self-Aligning Swivel Loading Head

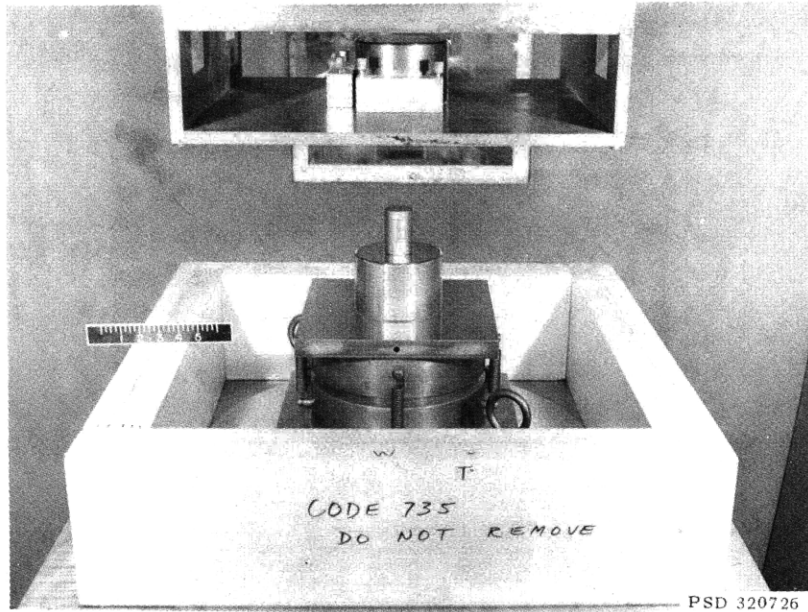

Figure A14 – Adaptor Box Around Swivel Head and Three-Piece Steel Frame Attached to the Top Head of the Testing Machine

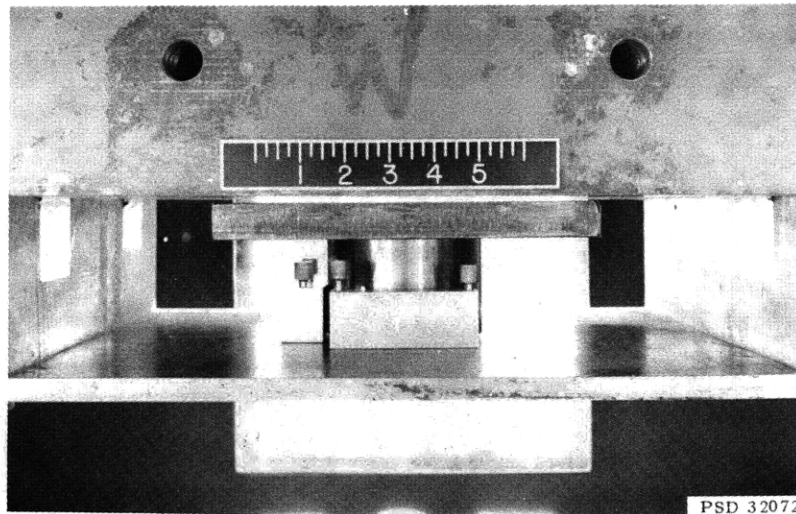

Figure A15 – Three-Piece Frame Attached to Top Head of Testing Machine with Alignment Blocks, Hardened Steel Bearing Block, and 18-Percent Nickel Maraging Steel Plate in Position

blocks center the upper hardened steel bearing block along the axis of testing by simply pushing it into the angle they form.

Figure A16 shows a rubber drop cloth positioned over the swivel head. On the top of the swivel head is another 18-percent nickel maraging steel plate; it is partially covered by a rubber sheet. A hardened steel block and a glass specimen are shown after centering on top of this maraging steel plate; the centering was accomplished using the fixtures shown later, (Items 5-9 inclusive of Figure A21).

Figure A16 also shows two of the four hinged sides of the protective spall shield that is positioned around the specimen during testing. As can be seen in this photograph, the observation windows can be sand blasted by fragments at the time of specimen rupture and should be protected by plexiglass throwaways. The method used to close off the top of the testing area is indicated at the top left of the spall shield.

Figure A17 shows the setup with a piece of fire hose used around the specimen to act as an extra shield and to contain more of the fragments generated by the breaking specimen.

Figure A18 indicates the setup for an actual test and details of damage after test. Figure 18a shows the rest of the spall shield in place. Figure 18b shows the damage caused to the fire hose section by the fragments from a bursting specimen; note the fine glass fragments on the rubber drop cloth. Figure A18c shows the broken specimen after removal of the piece of hose. The condition of the surface of the hardened block after the test (Figure A18d) indicates why these blocks require refinishing after almost every test. In general, the higher the load at failure, the more the likelihood that the block will be indented and scratched by the specimen fragments.

Figure A19 shows a portion of an external shield built around the test setup. This shield is necessary to keep people away from the test setup and to give additional protection to the loading screws on the 600,000-lb testing machine.

## **METHODS FOR EXPOSING SPECIMENS TO ARTIFICIAL SEA WATER**

Specimens were exposed to artificial sea water at atmospheric pressure and at a pressure of 10,000 psi. In order to prevent the sea water from contacting the pressure vessel used to produce the 10,000 psi, the test specimens were sealed in a triple plastic bag filled with artificial sea water and then pressurized using a small pressure vessel and standard high-pressure hydraulic oil. The triple bag system not only prevented any leakage of the sea water into the oil system but also prevented any oil from getting into the sea water or on the specimens.

Figure A20 shows the triple bags used by the Center. The specimen was handled using new, clean cotton gloves each time (this was typical procedure for all specimens). The plastic bags were produced by heat sealing 0.006-in.-thick plastic sheet; the seams were approximately 1/8-in. wide. As can be seen in this figure, it was necessary to make a 45-deg seam across the corners to prevent leakage.



Figure A16 – Rubber Drop Cloth Used in Test Setup to Protect Swivel Head and Showing Part of Spall Shield

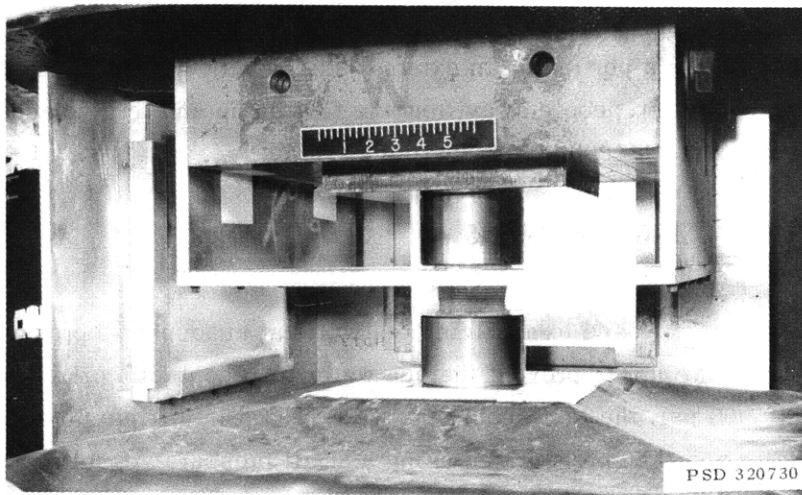

Figure A17 – Test Setup before Positioning of Spall Shield

Figure A18. – Setup for an Actual Test of Large Specimen

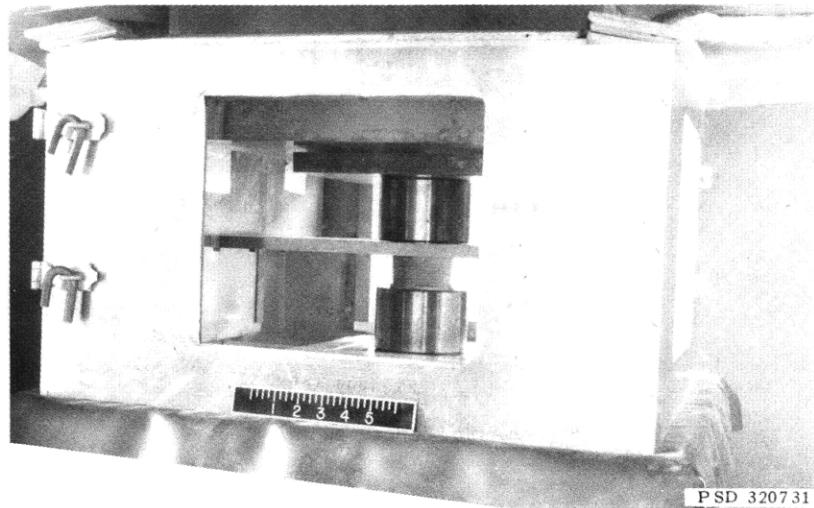

Figure A18a – Test Setup with Spall Shield in Place

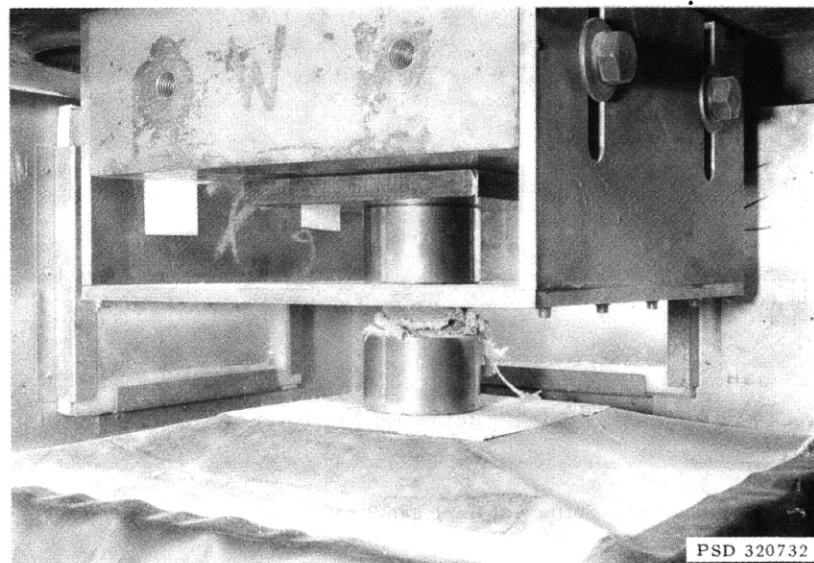

Figure A18b – Interior of Spall Shield after Test



Figure A18c — Specimen after Test

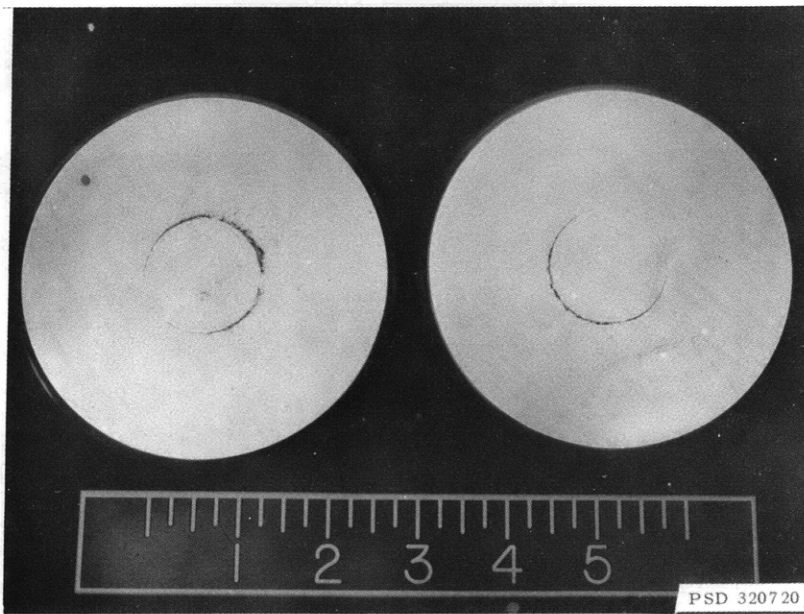

Figure A18d — Surface of Hardened Steel Bearing Blocks after Test



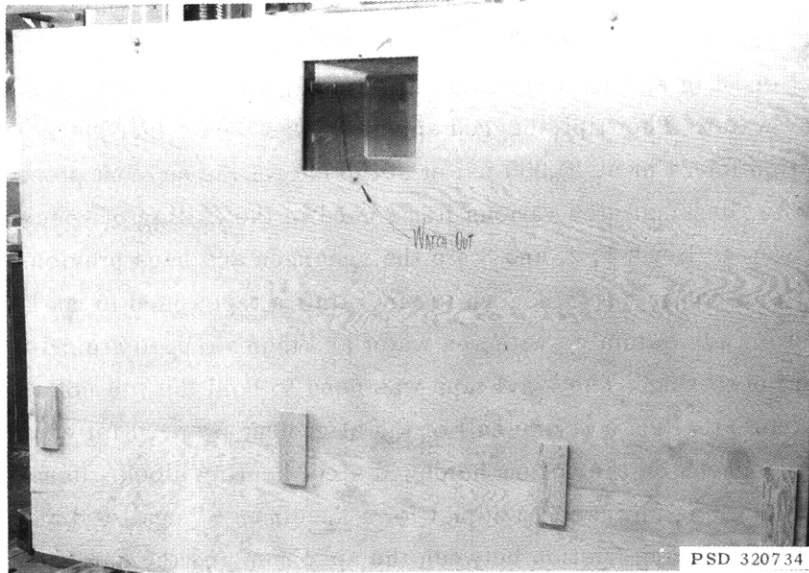

Figure A19 – Portion of External Shield around Testing Machine

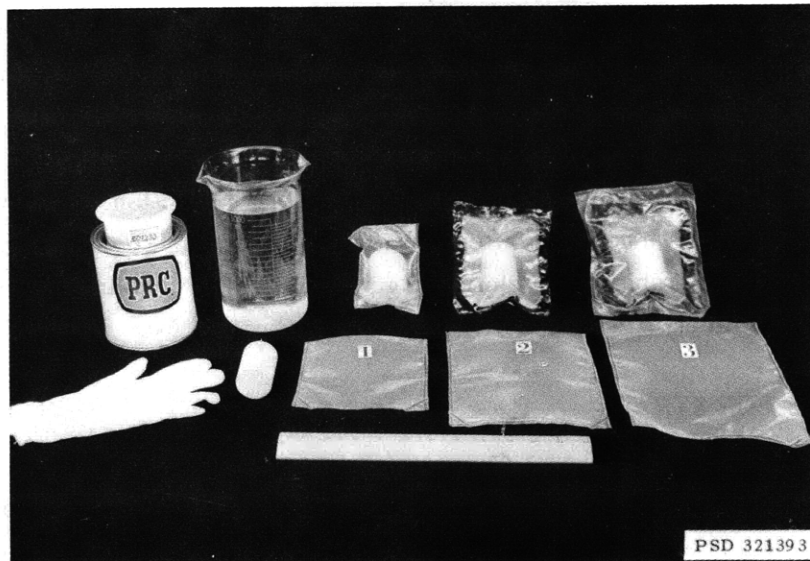

Figure A20 -- Triple Plastic Bag Filled with Artificial Sea Water

The procedure followed was to place the specimen in the first bag; fill it full of water, and heat seal it. The first bag was put in the second bag which was partially filled with sea water and then heat sealed. The edges of the second bag were coated with PRC. The sealed second bag was then put into the third bag which was heat sealed without the addition of any water. The triple-bagged specimen was then either put in the pressure vessel for pressurization for 24 hr at 10,000 psi or set aside for the ambient pressure exposure.

Figure A21 demonstrates various items used in the testing of specimens after exposure to sea water. Items 1, 2, and 3 are the specimen and bags previously discussed. Item 4 is a strip of cotton batting on white vinyl traffic tape (used to mark aisles on shop floors); the cotton was saturated with sea water and then wrapped around the specimen to keep it wet during testing. The vinyl tape was used to hold the wet cotton in place during the compression test. Item 5 is one-half of the alignment jig used for centering the largest compression specimens on the bottom hardened steel bearing block. Item 9 is the other half of this block containing an insert to adjust for a specimen of smaller diameter. Item 6 is silicon grease for reducing friction between the specimen and the hardened steel bearing blocks; the grease was always put on the hardened block instead of directly on the specimen. Item 7 is a 7075-T6 alignment block used to center the lower hardened steel bearing block relative to the position of the upper bearing block as shown in Figure A15. The small-diameter top of this block fits into the steel frame bolted to the top head of the testing machine, see Figure A14. Item 8 is to align blocks (also shown in Figures A14 and A15) which are positioned by their centering pins in the frame attached to the upper head of the testing machine, and are used to align the upper hardened steel bearing block. A precision level (also shown in Figure A21) was used before every test to level the swivel head shown in Figures A12 and A13.

Figure A22 indicates the setup for testing specimens exposed to artificial sea water. Figure A22a shows a specimen in position and wrapped with cotton wetted with sea water. Figure A22b shows the same setup after testing; again one can see the fragments of specimen scattered over the rubber drop cloth. Figures A22c and A22d are closeups of the specimen and hardened block after the test.

## **PROCEDURES FOR STRAIN-GAGED SPECIMENS**

Some large specimens were instrumented with strain gages prior to testing in order to evaluate the modulus and to measure the Poisson effects. The following series of photographs shows how the specimens were tested and some of the instrumentation and procedures used. Except for the extra instrumentation involved, these tests were run exactly as were the tests described for the other large specimens.

Figure A23 displays one side of the large specimens with adjacent axial and circumferential gages; matching gages are placed symmetrically on the opposite side. This



Figure A21 – Various Items Used in Testing Specimens  
after Exposure to Artificial Sea Water

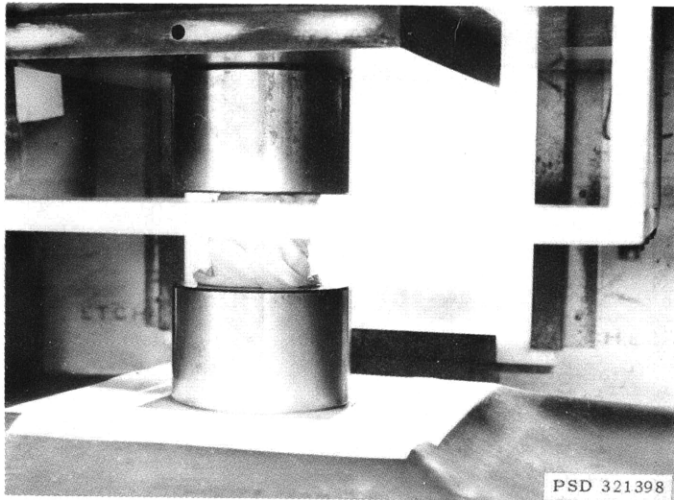

Figure A22a – Specimen Wrapped in Wet Cotton prior to Test

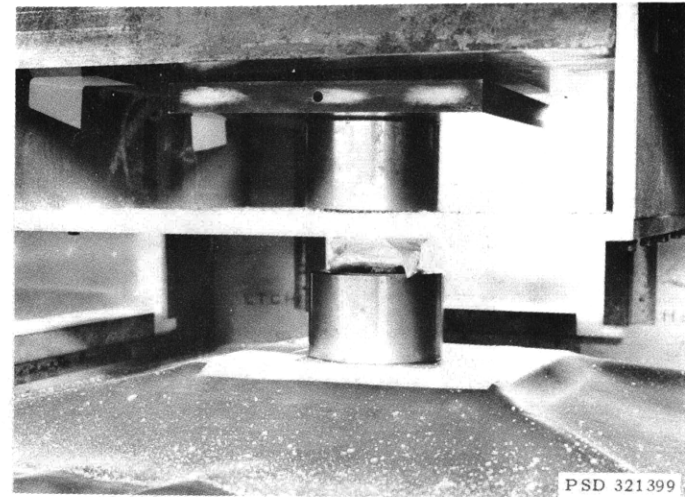

Figure A22b – Specimen Wrapped in Wet Cotton after Completion of Test



Figure A22c – Specimen and Hardened Bearing Blocks after Test

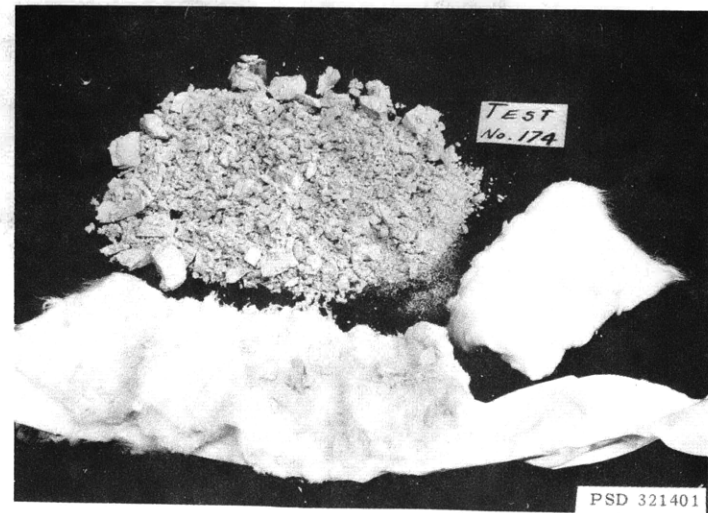

Figure A22d – Closeup of Specimen Fragments after Test

Figure A22 – Setup for Testing Specimens Exposed to Artificial Sea Water

photograph shows a special sintered tungsten carbide block (maximum 3 percent cobalt) with a hardness of Rockwell A 90/94, that was used as a bearing block for some of these tests. This material (Carbet CA4) proved to be especially resistant to brinelling and scratching by the specimen and its fragments during the tests. Figure A24 shows the testing of a piece of the material provided by the specimen manufacturer for use as a temperature-compensating dummy gage. It should be noted that it is much better practice to use another specimen as the dummy block if it is at all possible to do so.

Figure A25 shows the two-channel, strip-chart, load-strain recorder, switch boxes, and dummy gage block used in these tests. Note that the same length of lead wire was used to attach the dummy as was needed to reach the test specimen.

Because of the explosive release of energy and fragments produced when a specimen breaks, it is necessary to protect test equipment and personnel from possible injury. One method involves wrapping specimens in vinyl tape to help contain the fragments (Figure A26). The lead wire to the gages is taped to the overhead to keep any possible strain off the gages from this source. However, an old piece of fire hose (Figure A27) proved more effective than vinyl tape in containing specimen fragments. The aluminum spall shield presented earlier in Figure A26 is shown in Figure A28a after assembly; the spray on the window of the box is gray dust from a broken specimen. Pieces of the broken specimen and gages after test are indicated in Figure A28b and Figure A28c shows the bearing blocks after test. It was observed during these tests that the higher the load on the specimen at failure, the finer the fragments and the greater the damage to the bearing blocks.

## SUMMARY

The preceding sections have shown that testing glass or ceramic materials in compression calls not only for special procedures and techniques but for special precautions as well. Hard, brittle materials that explosively shatter during testing are particularly sensitive to specimen preparation and handling, specimen alignment, test fixturing, and loading conditions. In general, these factors are independent of specimen size.

### Test Specimens

Extreme care is necessary in preparation to ensure that the specimens are all made with the ends precisely parallel to each other and perpendicular to the axis of the specimens. Every effort should be made to maintain a truly circular specimen cross section. Since the edges of the specimen frequently flake or chip off during manufacturing and subsequent handling, consideration should be given to producing specimens with a specified small radius on all edges; such a specimen gives more consistent test results. Surface finish is an important variable that must also be controlled. Surface condition must be maintained by careful handling and storing of specimens prior to and during testing.

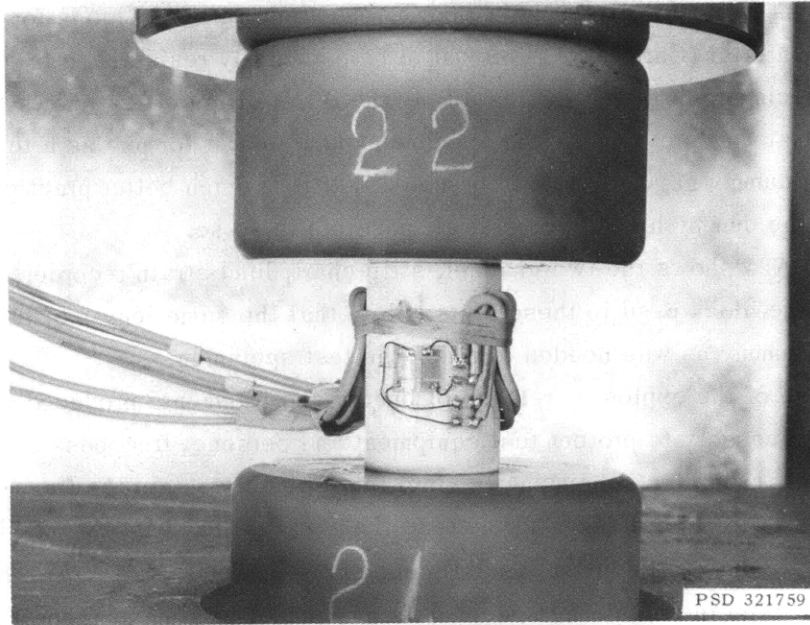

Figure A23 – Strain-Gaged Specimens and Sintered Tungsten Carbide Bearing Blocks

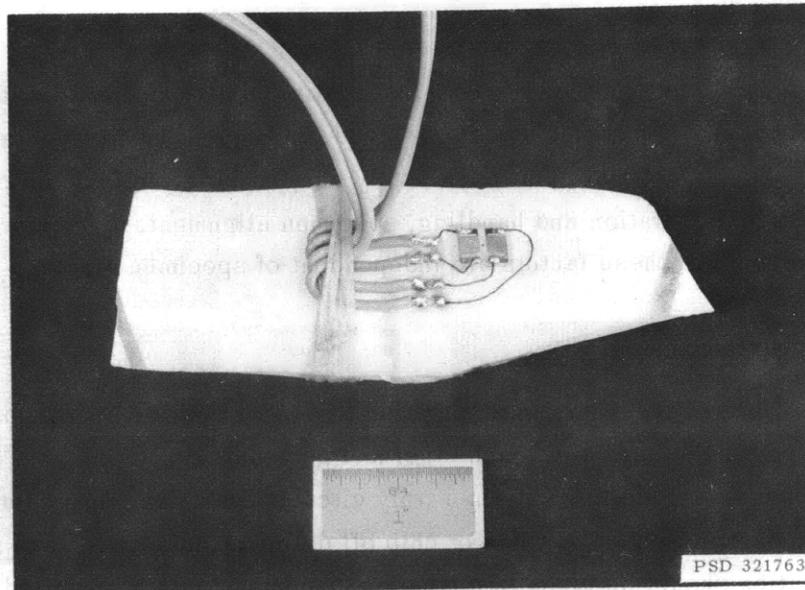
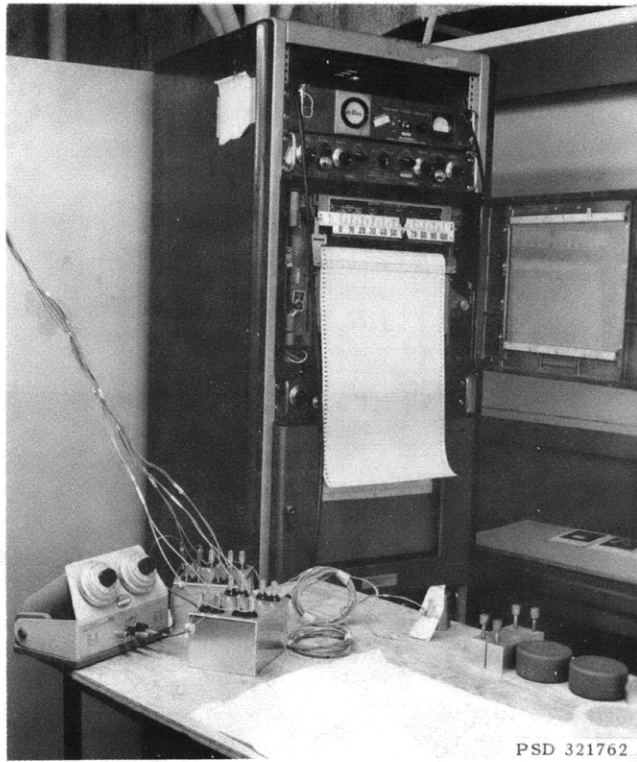
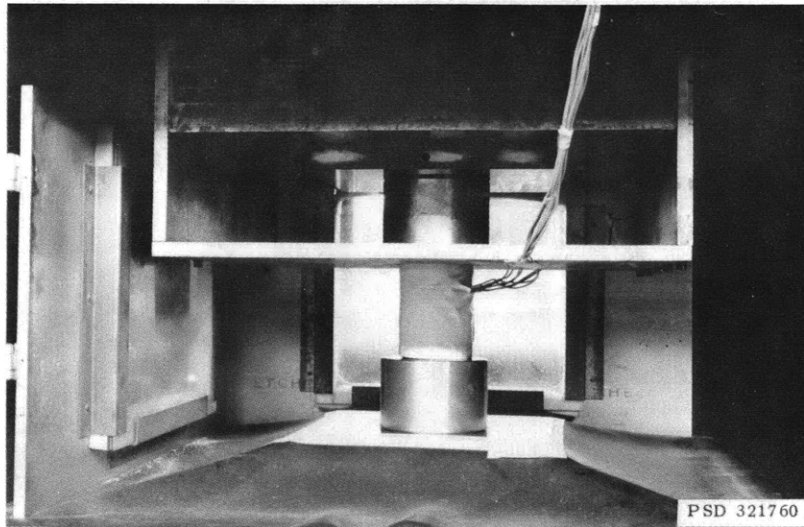

Figure A24 – Temperature-Compensating Dummy Gage



PSD 321762

Figure A25 – Strip Chart Recorder, Switch Boxes, and Dummy Gage



PSD 321760

Figure A26 – Strain-Gaged Specimen Wrapped in Vinyl Tape to Contain Fragments

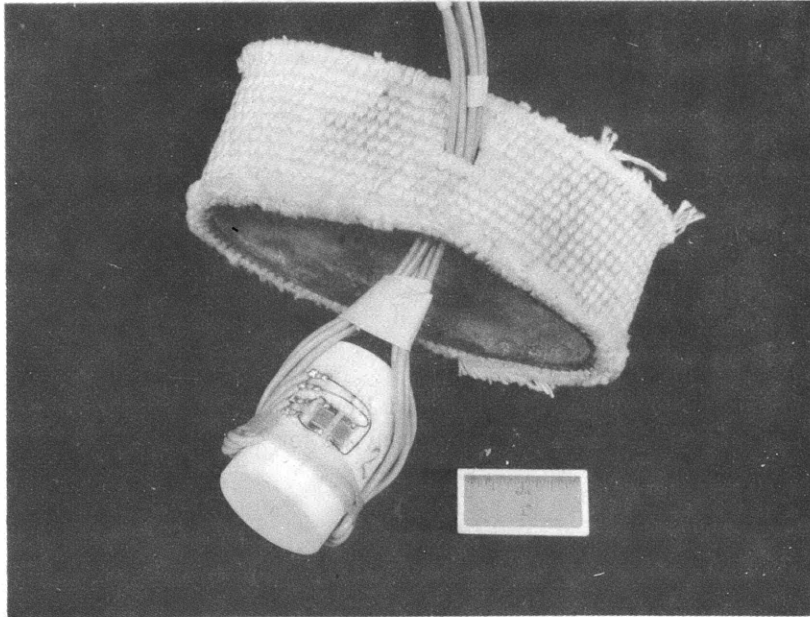

Figure A27 – Strain-Gaged Specimens Placed in Section of Fire Hose to Contain Fragments



Figure A28 – Setup for Testing Strain-Gaged Specimens

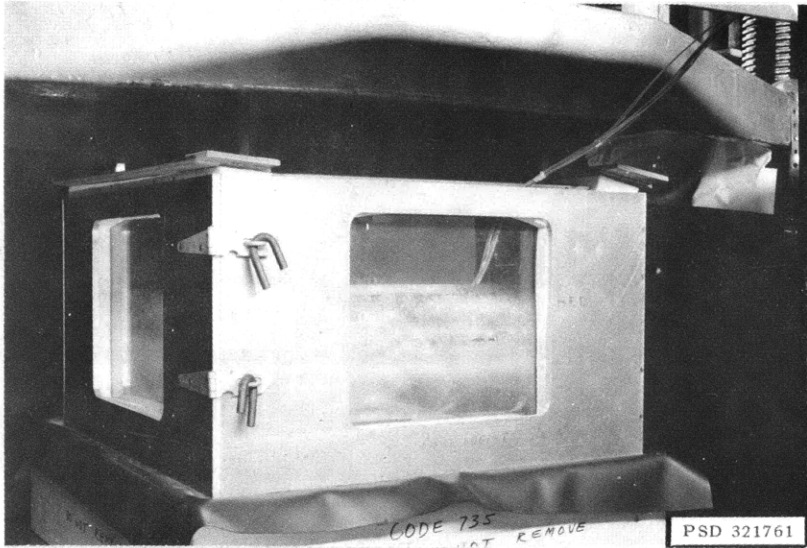

Figure A28a – Strain Gain Test Setup with Aluminum Spall Shield in Place

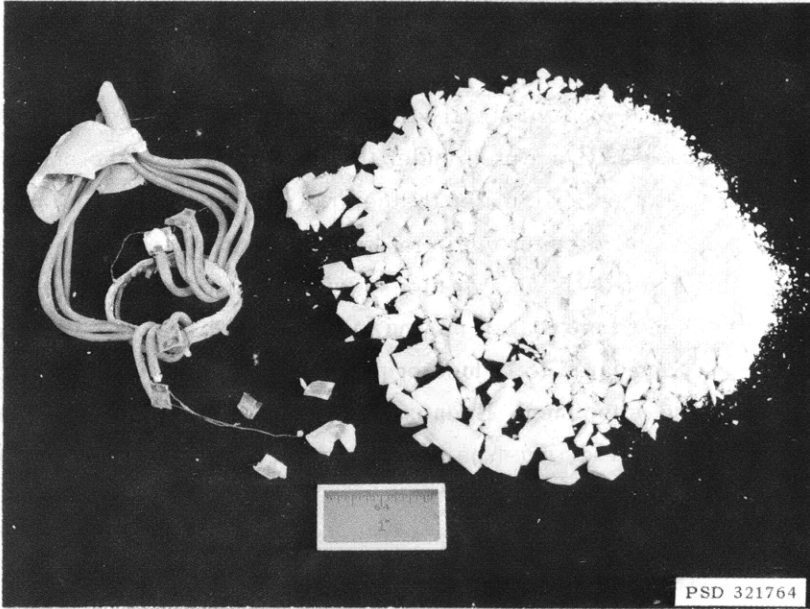

Figure A28b – Broken Specimens and Gages after Test



Figure A28c – Bearing Blocks after Test

### Test Procedures

The test procedures were basically the same for all specimens. The base of the testing machine must be carefully centered under the loading head. The specimen and all test fixtures must be aligned precisely under the central axis of the loading press. Self-aligning swivel heads must be used to ensure uniform loading across the ends of the specimens. Extremely hard, absolutely smooth bearing blocks with parallel surfaces have to be prepared and used with each specimen to prevent or minimize the brinnelling of the block by the specimen; these blocks must be lubricated to reduce or preferably eliminate the frictional restraint imposed on the ends of the specimen. Because fragments are explosively scattered when a glass specimen breaks, shields must be used to protect personnel as well as the moving parts of test fixtures and equipment.

## REFERENCES

1. Krenzke, M. A., "Exploratory Tests of Long Glass Cylinders under External Hydrostatic Pressure," David Taylor Model Basin Report 1641 (Aug 1962).
2. Krenzke, M. A., and Charles, R. M., "The Elastic Buckling Strength of Spherical Glass Shells," David Taylor Model Basin Report 1759 (Sep 1963).
3. Perry, H. A., "Massive Glass for Deep Submergence," Naval Research Laboratory Report 6167 (4 Nov 1964).
4. Stachiw, J. D., "Investigation into the Requirements of Deep-Submergence Torpedo Shells," David Taylor Model Basin Report C-1327 (Mar 1963) CONFIDENTIAL.
5. Kiernan, T. J., "An Exploratory Study of the Feasibility of Glass and Ceramic Pressure Vessels for Naval Applications," David Taylor Model Basin Report 2243 (Sep 1966).
6. Shand, E. B., "Glass Engineering Handbook," Second Edition, McGraw-Hill Book Company, Inc. (1958).

## INITIAL DISTRIBUTION

### Copies

- 4 NAVMAT
  - 2 DSSPO (PM 11)
  - 1 MAT 0331
  - 1 Spec Proj Off (PM 1)
- 5 NAVSHIPS
  - 2 SHIPS 2052
  - 1 SHIPS 031
  - 1 SHIPS 03423
  - 1 PMS 81
- 4 NAVSEC
  - 1 SEC 6101
  - 1 SEC 6129
  - 1 SEC 6110
  - 1 SEC 6111
- 1 CHONR (419)
- 1 NAVORD
  - 1 ORD 03A
- 1 USNASL (Code 9350)
- 1 Mr. R. Frownfelter, PPG
  - Industries, 1 Gateway Cen
  - Pittsburgh, Pa 15222
- 2 CO, USNOL
  - 1 W Dept
  - 1 WM Div
- 1 CO, USNRL (8430)
- 1 CDR, NUWC
- 1 CO & DIR, USNUSL
- 1 CO, USNROTC & NAVADMINU MIT
- 1 Webb Inst
- 1 CO, PGSCHOL, Monterey
- 20 DDC
- 1 WHOI
  - 1 Mr. J. Mavor
- 1 Dr. R. DeHart, SWRI
- 5 Mr. M. Simmons, Coors
  - Porcelain Co., Golden, Colorado

### Copies

- 1 NAVAIRSYSCOM
  - 1 Air 5-2032A
  - Attn: Mr. C. R. Bersch
- 1 Dr. R. Comish, IITRI
- 1 Mr. K. Pollock, Corning Glass Works
- 6 Dept of Chemical and Metallurgical
  - Engineering, Univ of Michigan
  - 2 Prof. L. Van Vlack
  - 1 Prof. M. J. Sinnott
  - 1 Prof. C. A. Seibert
  - 1 Prof. W. A. Hosford
  - 1 Prof. E. Young
- 2 Dept of Mech Engineering,
  - Univ of Michigan
  - 1 Prof. R. C. Juvinal
  - 1 Prof. D. K. Felbeck
- 6 American Society for Testing Materials
  - 3 ASTM Committee C-14
  - 3 ASTM Committee C-21

UNCLASSIFIED

Security Classification

DOCUMENT CONTROL DATA - R & D

(Security classification of title, body of abstract and indexing annotation must be entered when the overall report is classified)

1. ORIGINATING ACTIVITY (Corporate author) Naval Ship Research and Development Center Washington, D. C. 20007	2a. REPORT SECURITY CLASSIFICATION <b>UNCLASSIFIED</b>
	2b. GROUP

3. REPORT TITLE  
**THE EFFECTS OF SIZE AND ENVIRONMENT ON THE UNIAXIAL COMPRESSIVE BREAKING STRENGTH OF GLASS, ALUMINA, PYROCERAM**

4. DESCRIPTIVE NOTES (Type of report and inclusive dates)  
**Final**

5. AUTHOR(S) (First name, middle initial, last name)  
**Dionides H. Moreno  
Marcel L. Salive**

6. REPORT DATE <b>May 1970</b>	7a. TOTAL NO. OF PAGES <b>49</b>	7b. NO. OF REFS <b>6</b>
-----------------------------------	-------------------------------------	-----------------------------

8a. CONTRACT OR GRANT NO.  b. PROJECT NO. <b>SF 013 01 02, Task 0222 WP 725-334-02</b>  c.  d.	9a. ORIGINATOR'S REPORT NUMBER(S) <b>Report 3315</b>
	9b. OTHER REPORT NO(S) (Any other numbers that may be assigned this report) <b>AD 707 340</b>

10. DISTRIBUTION STATEMENT  
**This document has been approved for public release and sale; its distribution is unlimited.**

11. SUPPLEMENTARY NOTES	12. SPONSORING MILITARY ACTIVITY <b>Special Projects Office (NSP-001) Deep Submergence Special Projects</b>
-------------------------	--

13. ABSTRACT

The effects of size and environment on the uniaxial compressive breaking strength of glass, alumina, and pyroceram were investigated to establish realistic design criteria applicable to deep-depth hulls and/or buoyancy systems of nonmetallic materials. The influence of specimen size (diameters of 1/2, 1, and 1 1/2 in.), test environment (air, atmospheric sea water, and sea water at 10 ksi) and strengthening level (50 and 100 ksi) are discussed and tentative conclusions drawn on the basis of test results for a limited number of specimens. A rather complete description of the test procedures used is included in the Appendix to this report.

14. KEY WORDS	LINK A		LINK B		LINK C	
	ROLE	WT	ROLE	WT	ROLE	WT
Glass Alumina Pyroceram Compressive Properties Environmental Effects Stressing Rate Effects Size Effects Test Methods						

MIT LIBRARIES DUPL  
3 9080 02753 7171

NOV 29 1974