

V393
R46

2

LIBRARIES



3 9080 02754 4284

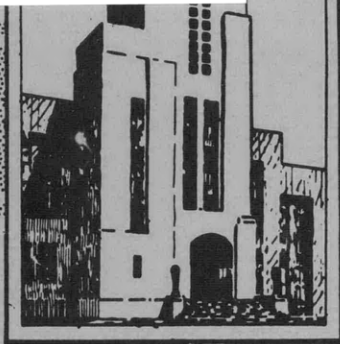

DEPARTMENT OF THE NAVY
DAVID TAYLOR MODEL BASIN

HYDROMECHANICS

THE HIGH-SPEED BASIN AND INSTRUMENTATION
AT THE DAVID TAYLOR MODEL BASIN

AERODYNAMICS



by

K. E. Schoenherr, Ph.D. and
W. F. Brownell

STRUCTURAL
MECHANICS



APPLIED
MATHEMATICS

HYDROMECHANICS LABORATORY
RESEARCH AND DEVELOPMENT REPORT

January 1963

Report 1660

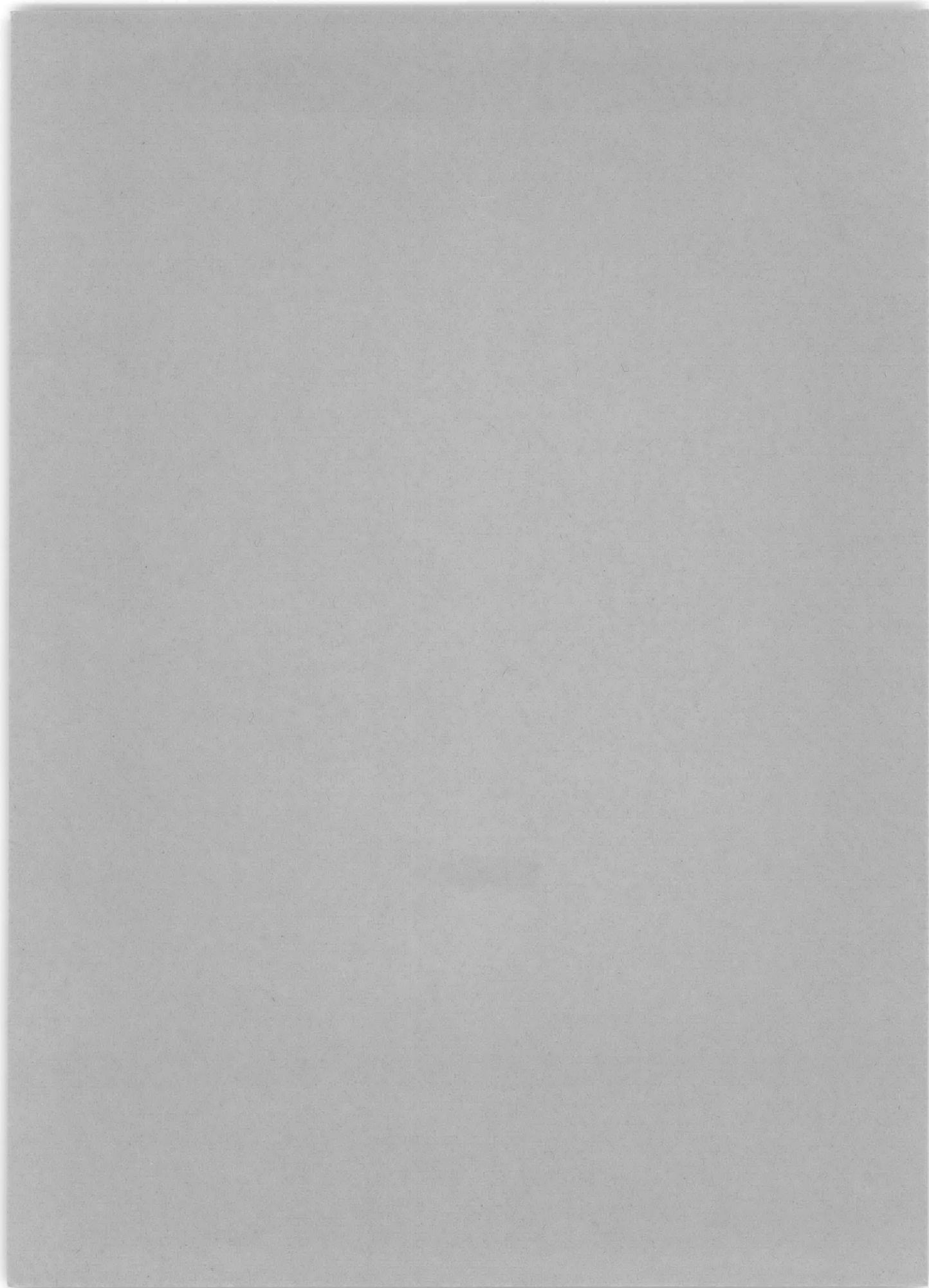

**THE HIGH-SPEED BASIN AND INSTRUMENTATION
AT THE DAVID TAYLOR MODEL BASIN**

by

**K. E. Schoenherr, Ph.D. and
W. F. Brownell**

**Paper presented at the
17th Annual American Rocket Society Meeting,
Los Angeles, California
13 November 1962**

January 1963

Report 1660

TABLE OF CONTENTS

	Page
ABSTRACT	1
INTRODUCTION	1
HIGH-SPEED BASIN	2
TOWING CARRIAGES	4
60-Knot Towing Carriage 5	4
40-Knot Towing Carriage 3	8
INSTRUMENTATION	10
Transmission Dynamometers	10
315-Horsepower Contrarotating Torpedo Dynamometer	11
35-Horsepower Propeller Dynamometer	12
500-Horsepower Nacelle Dynamometer	13
General Purpose Dynamometers	13
Internal Resistance Dynamometers	15
Hydrofoil Dynamometer	15
Induction Motor Dynamometers	15
Carriage Speed Measurement	19
Carriage 3 Towing Gear and Dynamometer	20
NEW INSTRUMENTATION	23
Planar Motion Mechanism MK 2	23
Pitch Heave Oscillator No. 2	23
1000-Horsepower Supercavitating Propeller Dynamometer	24
Wavemaker and Wave Absorbers	24
Underwater TV Camera and Housing	24
CONCLUSIONS	25
ACKNOWLEDGMENTS	25
REFERENCES	25

LIST OF FIGURES

	Page
Figure 1 – Outline Plan of High-Speed Basin	3
Figure 2 – Cross-Sectional View of High-Speed Basin	3
Figure 3 – Model Showing Track Construction	4
Figure 4 – Carriage 5 with Steel Wheels	6
Figure 5 – Towing Bridge with Strut and Torpedo Attached	6
Figure 6 – General Arrangement of Carriage 5	7
Figure 7 – Carriage 3 Towing a Motor Boat	8
Figure 8 – General Arrangement of Carriage 3	9
Figure 9 – 315-Horsepower Contrarotating Torpedo Dynamometer	11
Figure 10 – 35-Horsepower Propeller Dynamometer	12
Figure 11 – 500-Horsepower Nacelle Dynamometer in Calibration Stand	13
Figure 12 – 500-Horsepower Nacelle Dynamometer Test Setup	14
Figure 13 – 5-Horsepower, 100-Pound-Inch Propeller Dynamometer and Motor Ready for Surface Model Installation	16
Figure 14 – Exploded View of 5-Horsepower, 50-Pound-Inch Propeller Dynamometer	16
Figure 15 – 4000-Pound Internal Resistance Dynamometer	17
Figure 16 – Hydrofoil Dynamometer with Tow Bridge	18
Figure 17 – Modular Force Gage	19
Figure 18 – 400-Horsepower Induction Motor Dynamometers	20
Figure 19 – Carriage 3 Dynamometer and Towing Gear No. 1	21
Figure 20 – Carriage 3 Dynamometer and Towing Gear No. 2	22

ABSTRACT

This paper describes the 2968-ft high-speed basin and several instrumentation systems used for testing a wide variety of models such as full-scale torpedoes towed and self-propelled, hydrofoils, planing boats, pumpjets, propellers, and other high-speed vehicles. Information concerning the basin; towing carriages; and propulsion, force, and speed measuring instrumentation is presented. Typical test procedures and usage of the carriages are discussed. New instrumentation nearing completion, which will greatly extend the high-speed basin testing capabilities, is described.

INTRODUCTION

Hydrodynamic facilities for measuring resistance and propulsion characteristics of surface ships, submarines, and other underwater vehicles are generally characterized by moving the test model or body through the surrounding water rather than by moving the water past the stationary model. The advantages of this system are the ability to maintain steady speed relative to the medium well within 1/100 of a knot, which in turn permits measuring drag to 1/100 of a pound, and to use large models and large ratios of channel cross section to model cross section without excessive power requirement. The principal disadvantages are the high first cost of such a facility, because the towing basin has to be quite long to allow for acceleration and deceleration as well as the steady speed run, and a relatively inefficient operating cycle.

Testing of surface ship models requires Froude scaling; that is the model test speed is lower than the full-scale speed in the ratio of the square root of the model length to ship length. Therefore, the maximum speed of a towing carriage designed for surface ship work need not exceed, say, 18 knots (21 mph). On the other hand, testing of fully submerged bodies, such as torpedoes with a drag which is primarily frictional, requires Reynolds scaling for complete similitude of flow conditions. Although complete similitude of flow is usually not obtainable and is not mandatory for practical purposes, nevertheless, the test speed must be relatively high in order to avoid large scale-effect errors. Therefore, for this type of testing, carriage speeds of 50 knots and higher are desirable. These conflicting speed requirements were resolved in the design of the Taylor Model Basin¹ by providing two towing basins, one designed primarily for surface ship work and one for high-speed work. Inasmuch as this paper is concerned with facilities for the testing of torpedoes and similar underwater bodies, only the high-speed test facility will be described in detail. However, it should be mentioned that the low-speed facilities are of impressive size; actually, they comprise three basins end to end with a total overall length of about 3000 ft, a width of 51 ft, and a depth of 22 ft for all but 300 ft of the length.

¹References are listed on page 25.

HIGH-SPEED BASIN

The high-speed basin at the David Taylor Model Basin is used for testing both model-scale and full-scale torpedoes; hydrofoils; pumpjets; planing boats; sonar domes; wetted, ventilated, and supercavitating propellers; and other high-speed test bodies. The tests may relate to the measurement of propulsion characteristics, to the measurement of forces and moments acting on the model, or, in some cases, to the measurement of model-generated noise. The basin is housed in a reinforced concrete arch structure and is located alongside the surface ship model test basin mentioned previously. Figure 1 shows an outline plan of the interior of this structure. The roof of the building has a free span of 110 ft and a rise of 24 ½ ft. The structure is heated and ventilated to maintain about the same inside temperature throughout the year with some control over sweating obtained by the use of cork insulation on the walls above the concrete abutment.

The present high-speed basin is rectangular in cross section (see Figure 2); it is 2968 ft long, 21 ft wide, and 10 ft deep for 1168 ft of its length and 16 ft deep for the remaining 1800 ft. The basin walls are constructed of monolithic concrete sections; each section is 38 ft long separated by 2-ft gaps that were filled with reinforced concrete after the sections had set and shrunk. During construction, the basin was enclosed by the building to prevent large temperature variations.

Construction of the basin took place in two stages. In the first stage, commenced in 1937 and completed in 1940, a 1200-ft section was put into service. Actually, the original plans were to make the basin 1600 ft long, but the length was reduced when appropriations proved insufficient. This reduction limited the operational carriage speeds to 20 knots instead of the 35 knots for which the carriage had been designed. This speed limitation was keenly felt when the United States entered the last war and the development of high-speed quiet-running torpedoes became of paramount importance. It should be said that at that time the David Taylor Model Basin had the only facility in the western hemisphere capable of testing full-scale torpedoes under controlled laboratory conditions. In view of this situation, plans were made in 1943 to extend the basin to its present length. With the active support of the Bureau of Ordnance (the present Bureau of Naval Weapons) and the Bureau of Ships, work was commenced without delay. Although the war ended before the additional section was completed in 1947, the plans, nevertheless, proved to be far-sighted in that the expanded facilities have been fully occupied since completion and have been used in the development of all modern U. S. torpedoes as well as numerous other bodies and devices.

The basin walls are of concrete and support the steel tracks on which the towing carriages run. These concrete walls and the bottom of the basin go down to bedrock, thus furnishing a solid foundation for the tracks. The rails are set precisely in order to obtain the high degree of accuracy required for ship model tests. A typical detail of the track construction is shown in Figure 3. The rails are bolted to high-strength cast iron chairs which in turn are bolted to the concrete walls. The steel rails are of the railroad type and weigh 185

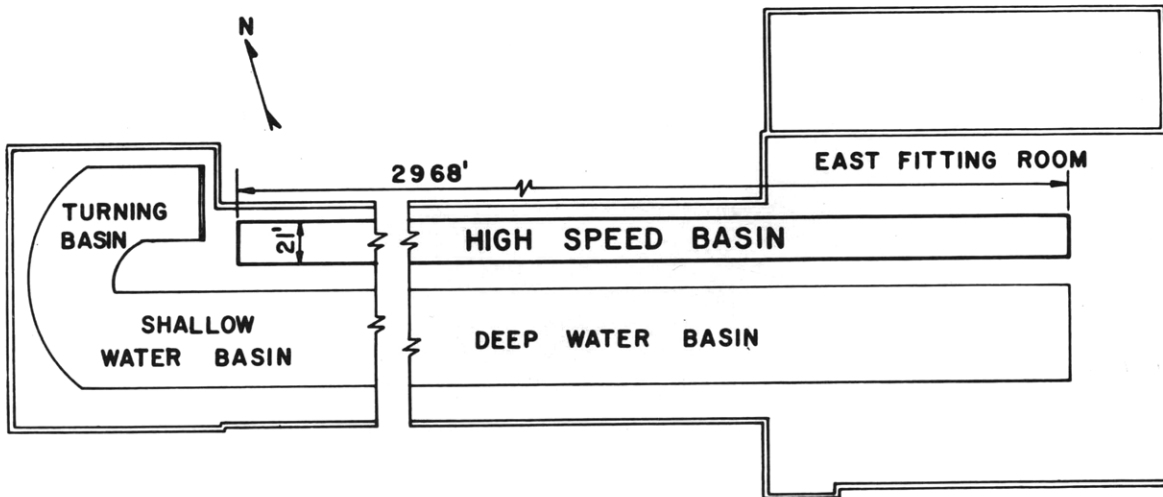

Figure 1 - Outline Plan of High-Speed Basin

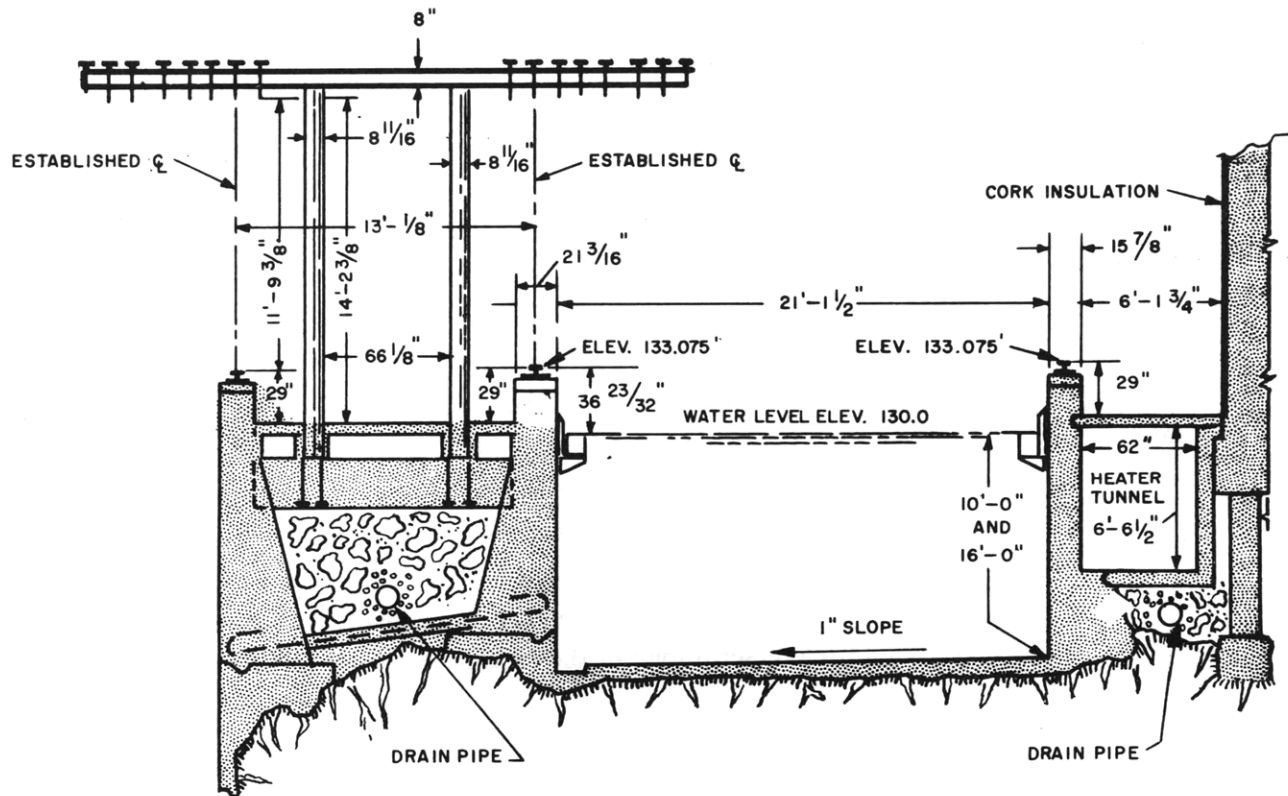

Figure 2 - Cross-Sectional View of High-Speed Basin

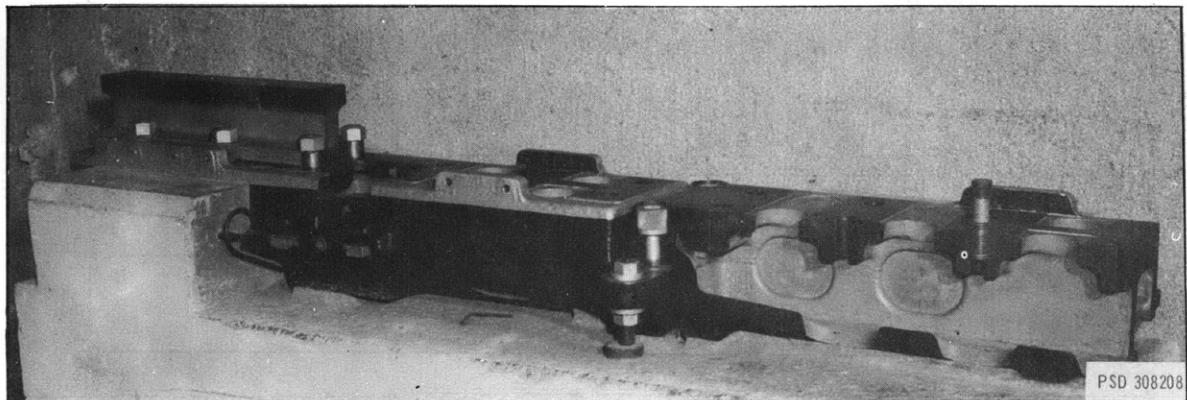

Figure 3 – Model Showing Track Construction

lb per yd except for those on the north side of Section One which weigh 165 lb per yd. The rails in general are about 31 ft long and are welded together throughout the length of the basin. The top and sides of the rail heads and the bottom of the rails are ground. The top of each rail is set within ± 0.005 in. of the water level along the length of the basin. The sides of the rail heads are set parallel to a vertical plane through the center of the basin within 0.005 in. in either direction throughout their length.

The basin is filled with fresh water which is fed by gravity from a conduit of the District of Columbia water supply that parallels the basin. The water is filtered by continually running a small portion of it through a sand bed filter. This facilitates taking underwater photographs through glass viewing ports set into the north wall about midlength. Waves and other disturbances generated during the measuring run are quenched in the interval between runs by wave absorbers. These absorbers are U-shaped troughs attached to the walls with their upper edges about $\frac{1}{4}$ in. below the water surface; see Figure 2.

Two towing carriages designated Carriage 3 and Carriage 5 serve the basin. Carriage 3 has a top speed of 40 knots (46 mph) and Carriage 5 has a top speed of 60 knots (69 mph). The 60-knot carriage has interchangeable wheels with one set equipped with rubber tires for noise tests, as will be explained in greater detail subsequently.

Propulsion dynamometers, force balances, etc., with their associated indicating and recording devices, are available in great number and diverse capacity. The remainder of this paper is devoted to detailed descriptions of the instrumentation and test procedures.

TOWING CARRIAGES

60-KNOT TOWING CARRIAGE 5

The towing carriages at the David Taylor Model Basin were designed on a deformation rather than on a stress basis in order to obtain a platform of great stiffness with minimum

deflections. This design has resulted in Carriage 5 being a large precision instrument² for conducting model tests at speeds up to 60 knots (69 mph); see Figure 4.

Carriage 5 is a welded tubular steel trusswork 70 ft long by 26 ft wide.³ The tubular members range from a 3-in. outside diameter by 0.188-in. wall to a 1 3/4-in. outside diameter by 0.156-in. wall. An open rectangular test bay 31 1/2 ft long by 10 ft wide is provided for mounting the towing bridges to which struts and test vehicles are attached. Figure 5 shows a towing bridge with strut and torpedo attached on shore. These bridges can be disconnected and removed readily from the carriage for model fitting without affecting the use of the carriage. The carriage with its basic drive equipment weighs about 100,000 lb; its drag load capacity is 8000 lb and side load capacity is 9000 lb. Actually the structurally safe drag load limit is 20,000 lb, but this limit cannot be used because it approaches the limit of the available tractive effort. The average length or run during which steady carriage speed can be maintained without a model ranges from about 2100 ft at 20 knots to 680 ft at 55 knots. Model drag increases the accelerating distance, thus these figures are outside figures.

The carriage is driven by twelve individual 250-volt, 3500-rpm, (maximum) d-c motors rated at 165 hp; see Figure 6. Each motor can develop 400 hp during the short time the carriage is accelerating. The motor armatures are connected in series in order to equalize the loads. A 17-bar trolley system installed along the north side of the basin provides the carriage with the power and control supplies required for operation. The electric drive for the carriage is an adjustable voltage d-c system with automatic feedback control which regulates the steady speed to within ± 0.06 knots or 0.1 percent of full-scale speed. Currently, a program is underway to further improve the carriage speed regulation by means of a higher gain control system along with new reference voltage and feedback signal systems.

The carriage motors drive thirty two steel wheels. Sixteen wheels, 40 in. in diameter, are vertical to carry the weight of the carriage. The remaining sixteen wheels are horizontal side drivers, 31.285 in. in diameter and assembled in opposed pairs, which press against the sides of the rail head and provide the additional tractive effort needed to accelerate the carriage. The side drivers on the south side of the carriage are guide wheels as well as drive wheels. The maximum tractive effort of the carriage is about 20,000 lb and the maximum average acceleration rate is about 0.16 g.

The sixteen vertical drive wheels can be fitted with rubber tires having steel cords and inflated by water pressurized to 280 psi. Side drivers are not used with the rubber-tired wheels as the greater coefficient of friction of rubber compared to steel provides sufficient traction for carriage acceleration. Acoustic tests are run in the basin with the rubber tires used on the carriage.

Normally, carriage braking is by regenerative action, with the drive motors acting as generators to feed power back into the lines. When a quicker stop is required, or if a power failure occurs, the carriage is stopped by mechanical track brakes mounted on the carriage. These brakes consist of spring-loaded brake shoes which grip the sides of the rail heads, with the deceleration rate about 0.5 g. If both braking systems fail, emergency braking can be

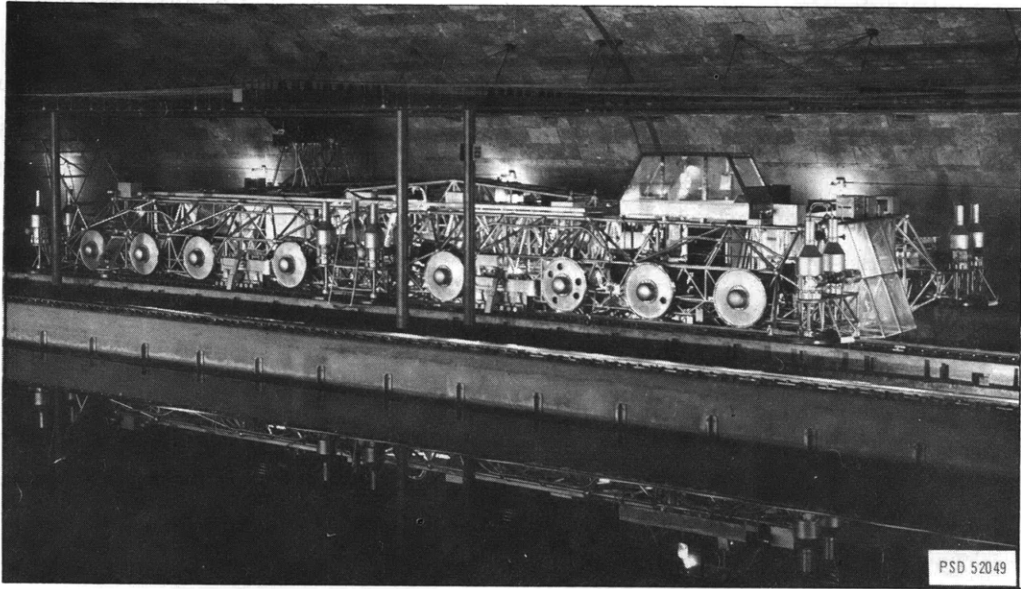

Figure 4 – Carriage 5 with Steel Wheels

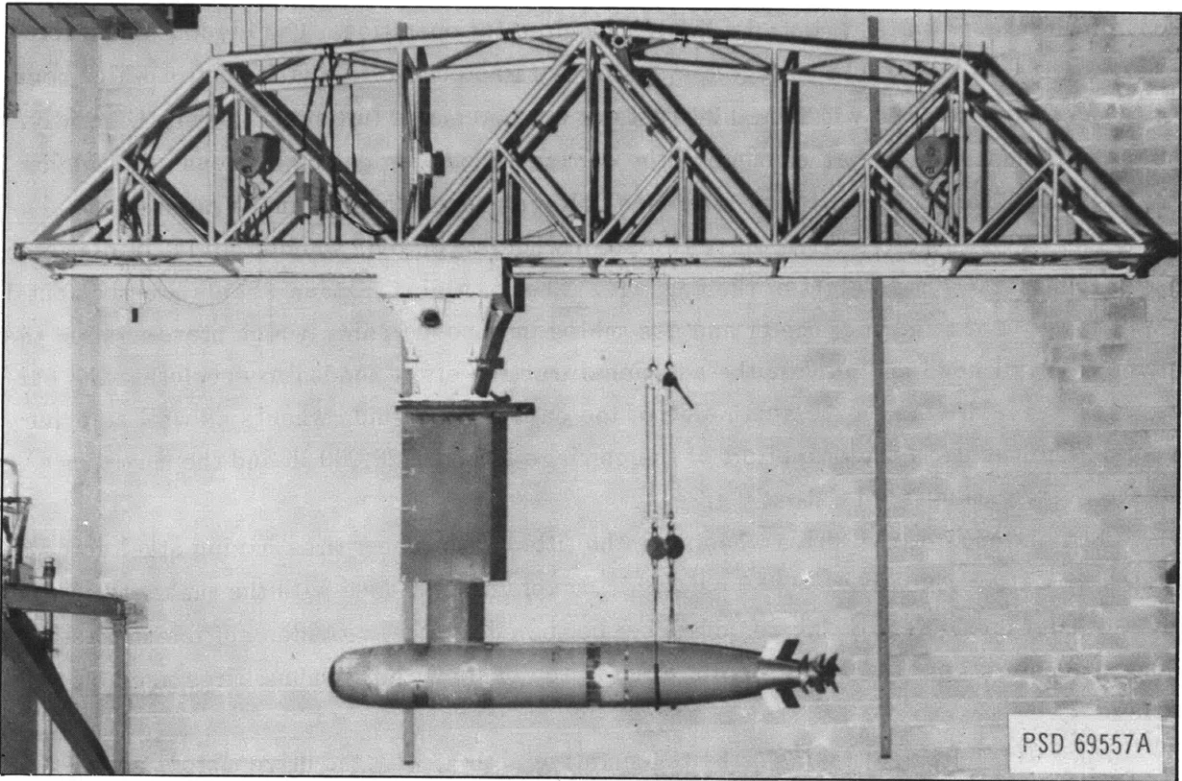

Figure 5 – Towing Bridge with Strut and Torpedo Attached

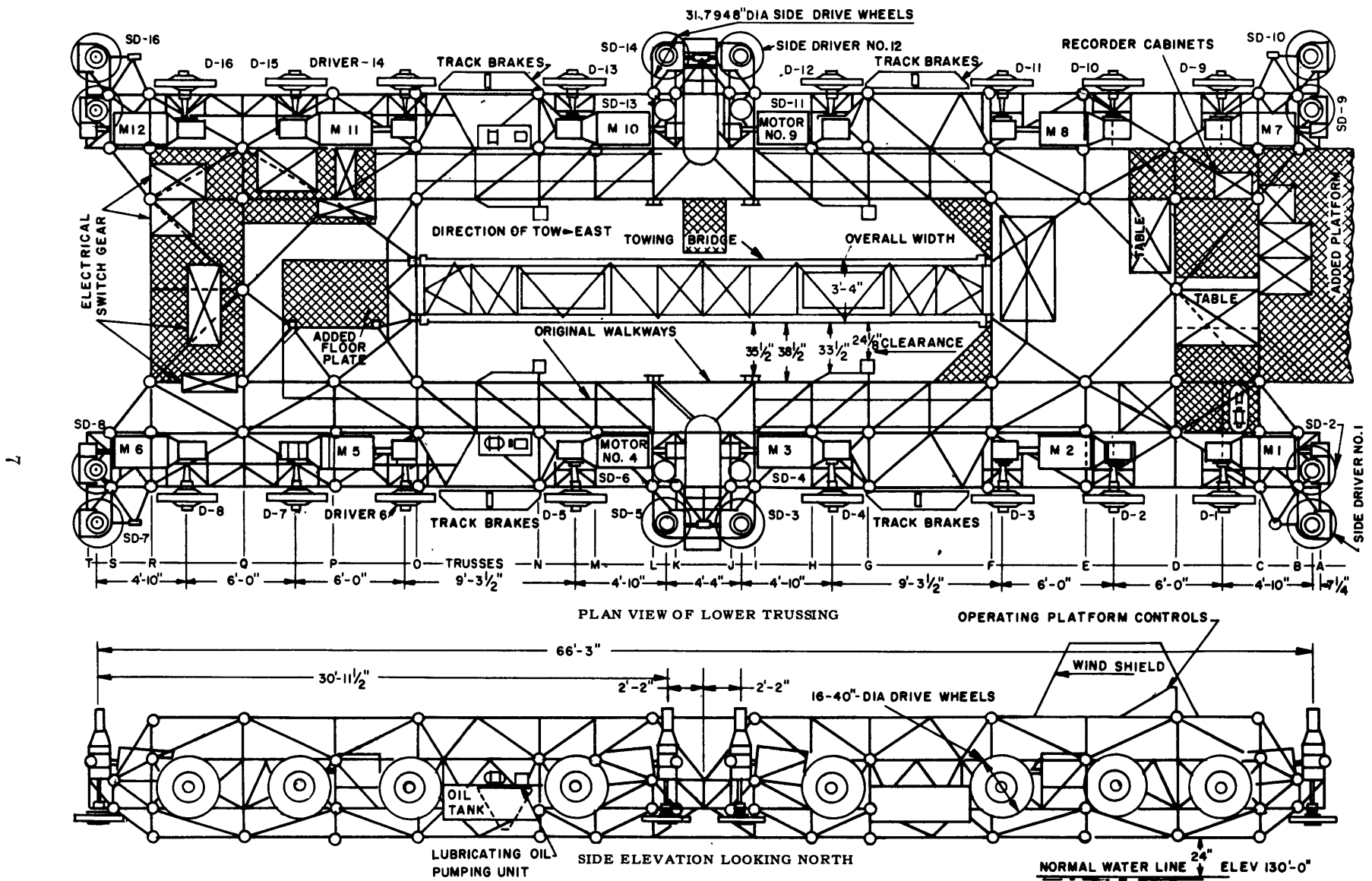

Figure 6 – General Arrangement of Carriage 5

obtained by tapered nose runners on the underside of the main frame of the carriage which enter spring-loaded shoes attached to the basin walls at the extreme end. The deceleration rate in this case is about 2 g.

Power supplies of 2500 and 1000 amperes are available for supplying up to 400 volts of direct current to powered models. In addition, a 600-volt a-c, 300 kva and a 50-kw model power supply are available.

40-KNOT TOWING CARRIAGE 3

Carriage 3 has a top speed of 40 knots (46 mph); it weighs about 30,000 lb and is designed for lighter towing loads than Carriage 5. The main towing dynamometer mounted on the carriage has a drag capacity of 150 lb. This carriage is used primarily for model testing of planing craft, hydrofoil boats, high-speed craft, and calibration of special devices such as speed logs; see Figure 7.

The carriage is a triangular-shaped welded tubular steel trusswork 24 ft 7 in. wide and 33 ft long on the south side and 11 ft 4 in. long on the north side. Figure 8 shows the general arrangement of the carriage. The tubular members range from a 3½-in. outside diameter by 0.145-in. wall thickness to a 1½-in. outside diameter by 0.065-in. wall thickness. The dynamometer bay is 3 ft 6 in. wide by 8 ft 5 in. long.

The carriage is driven by a 200-hp synchronous motor through a hydraulic drive. All driving machinery is on the south side of the carriage. There are four 40-in. vertical steel

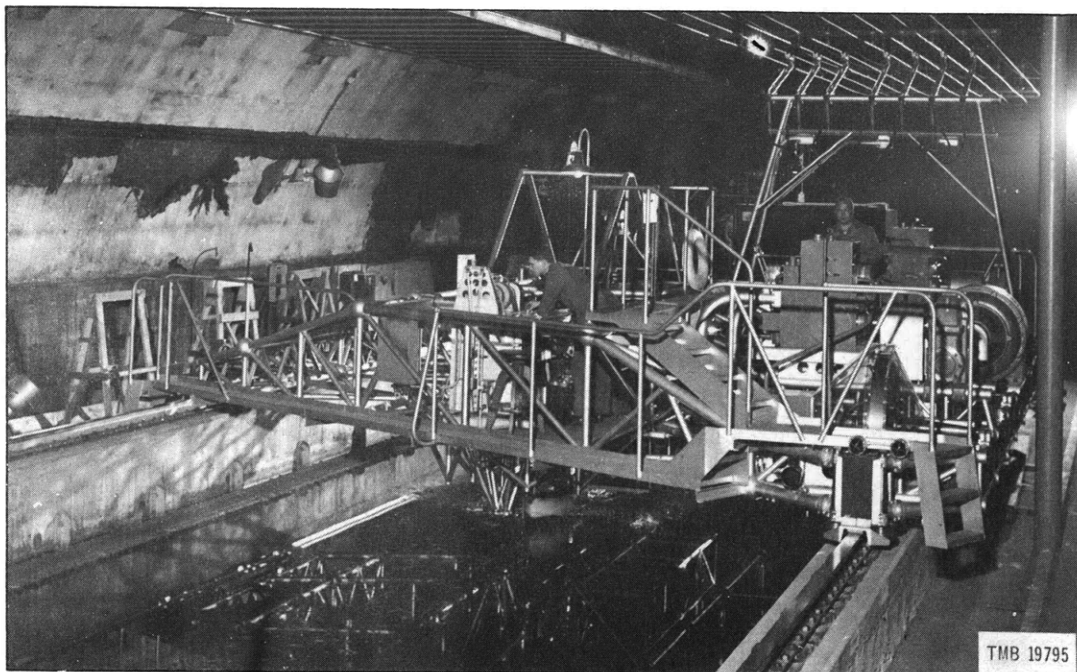

Figure 7 – Carriage 3 Towing a Motor Boat

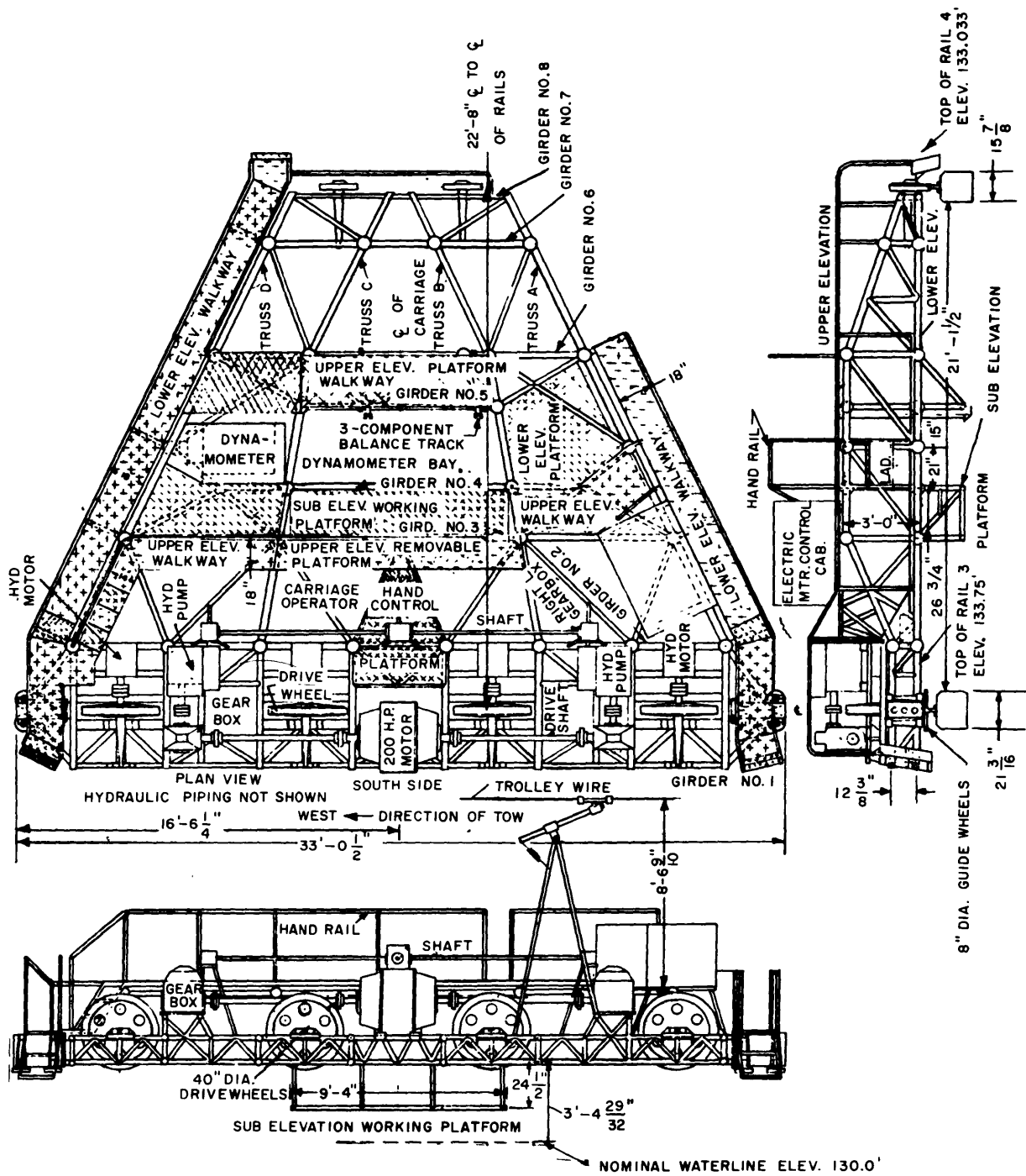

Figure 8 – General Arrangement of Carriage 3

drive wheels on the south side of the carriage and two 20-in. vertical steady wheels on the north side. The carriage is guided in a horizontal plane by groups of four 8-in. guide wheels located at each end of the south side of the carriage.

Each drive wheel is driven by a direct-connected oil motor which receives oil from a pump on the shaft of the 550-volt a-c synchronous motor. This motor obtains its power supply from the trolley system located over the south side of the carriage. In addition to the synchronous motor, there are two oil pumps and four oil motors. The synchronous motor drives the pump at constant speed. The variable control of the hydraulic system accelerates and drives the carriage at any selected speed. The same control is used to decelerate the carriage by using the oil motors as pumps, the oil pumps as motors, and the synchronous motor as a generator to pump power back into the line. This carriage operates from east to west, as contrasted to Carriage 5, which operates from west to east. Therefore, a spring-loaded mechanical track system similar to that used with Carriage 5 is provided for emergency braking at the west end of the basin.

Power supplies available for model power on Carriage 3 include a 0- to 400-volt d-c, 5-kw supply; a 600-volt a-c, 100-kva supply; and a 50-kw shore-based supply.

INSTRUMENTATION

A wide variety of instrumentation is available for model testing in the high-speed basin. Descriptions of some of this instrumentation are given to indicate the capacity and flexibility of this basin.

TRANSMISSION DYNAMOMETERS

Transmission dynamometers⁴ of the differential reluctance type are used for the measurement of model propeller-shaft torque, thrust, and revolutions. The dynamometers are fitted into the shaft between the drive motors and the propellers. The advantages of this type of dynamometer are high natural frequency in thrust and torque, elimination of slip rings, capability of wet operation, synchronization of propeller rpm by mechanical means, and relative insensitivity to dynamic load variation. They also are relatively small in size and independent of the drive motors, which permits using different types of motors to simulate full-scale power plant characteristics.

The differential reluctance-type transducers used at the David Taylor Model Basin are of these general forms: a displacement gage (magnigage), which in combination with flexure joints measures forces or moments; a torque gage (magnitorque); and a thrust gage (magnithrust).

The differential reluctance-type transducers operate on the principle that special flexural elements when under load increase one air gap and decrease another.⁵ The change

in air gaps results in a differential reluctance change which alters the voltage drops across two windings and gives an output signal proportional to load.

An automatic null-balancing system, in which the transducer and the indicator or recorder form a close-loop servo system, is used for measuring output and operates as follows: The transducer output is balanced by a potentiometer, the error signals from the transducer resulting from torque, thrust, or other force are amplified and drive a servomotor that positions the potentiometer to restore electrical balance to the system; the amount of potentiometer motion is a measure of the force. Digital indicators and graphical recorders are used for readout. Readings can be supplemented by a direct writing oscillograph when dynamic conditions prevail.

An electromagnetic counter pickup is used for measuring shaft revolutions. This pickup consists of a copper disk with ten radial slots and a pair of pickup coils which produce ten pulses per revolution. The pulses are counted over measured time intervals by suitable instrumentation and are indicated digitally in rpm or rps.

These dynamometers have an overall accuracy of $\pm \frac{1}{2}$ percent or better.

315-HORSEPOWER CONTRAROTATING TORPEDO DYNAMOMETER

This dynamometer (see Figure 9) is designed to measure torque and thrust in the contrarotating shafts of full-scale torpedoes. The dynamometer and propulsion motors are mounted

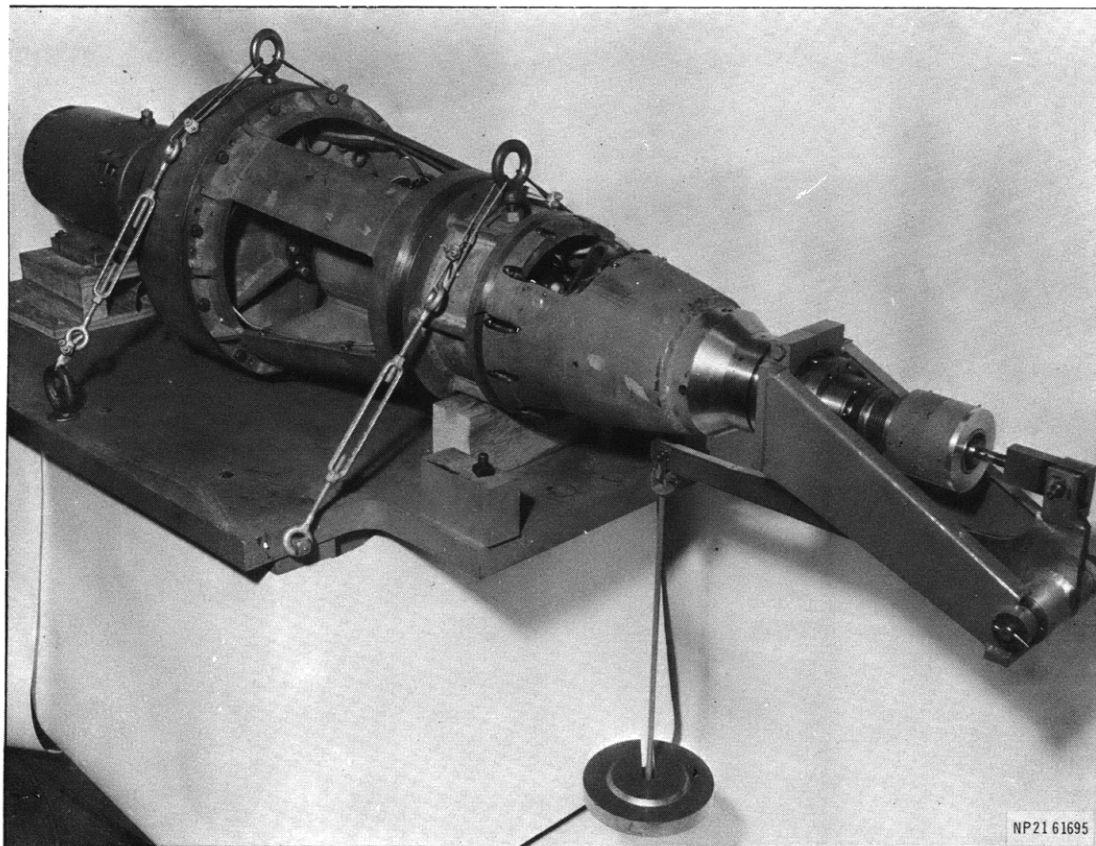

Figure 9 – 315-Horsepower Contrarotating Torpedo Dynamometer

inside the torpedo housing. The body is connected to one or two struts attached to a towing bridge which in turn is mounted in the dynamometer bay of Carriage 5. The propeller thrust is measured by the displacement of loop flexure elements in the magnigage transducer and the torque is measured in a similar manner with the magnitorque units. The capacities of the dynamometer are 330 lb-in. of torque and 600 lb of thrust at 3000 rpm per shaft. Readings are digitally indicated or graphically recorded.

35-HORSEPOWER PROPELLER DYNAMOMETER

The 35-horsepower propeller dynamometer is used for open-water characterization of propellers up to 20 in. in diameter. This dynamometer,⁶ built several years ago, consists of an underwater body housing a transmission-type dynamometer. To avoid interference, the test propeller is supported on a sting well forward of the main body; see Figure 10. The assemblage is supported by struts secured to the towing carriage. The dynamometer drive motor, which is located above water, drives through a vertical shaft and right angle gear box located in the underwater body. Signals from the transducers are transmitted through sliprings and a manual null-balancing system is used to obtain digital readings. The capacity of this dynamometer permits measuring transmission of 35 hp through the shaft at 1000 to 2500 rpm. In terms of thrust and torque, the capacity is 700 lb of thrust in ahead operation and 200 lb in astern operation; the maximum torque capacity is 21,600 in-lb.

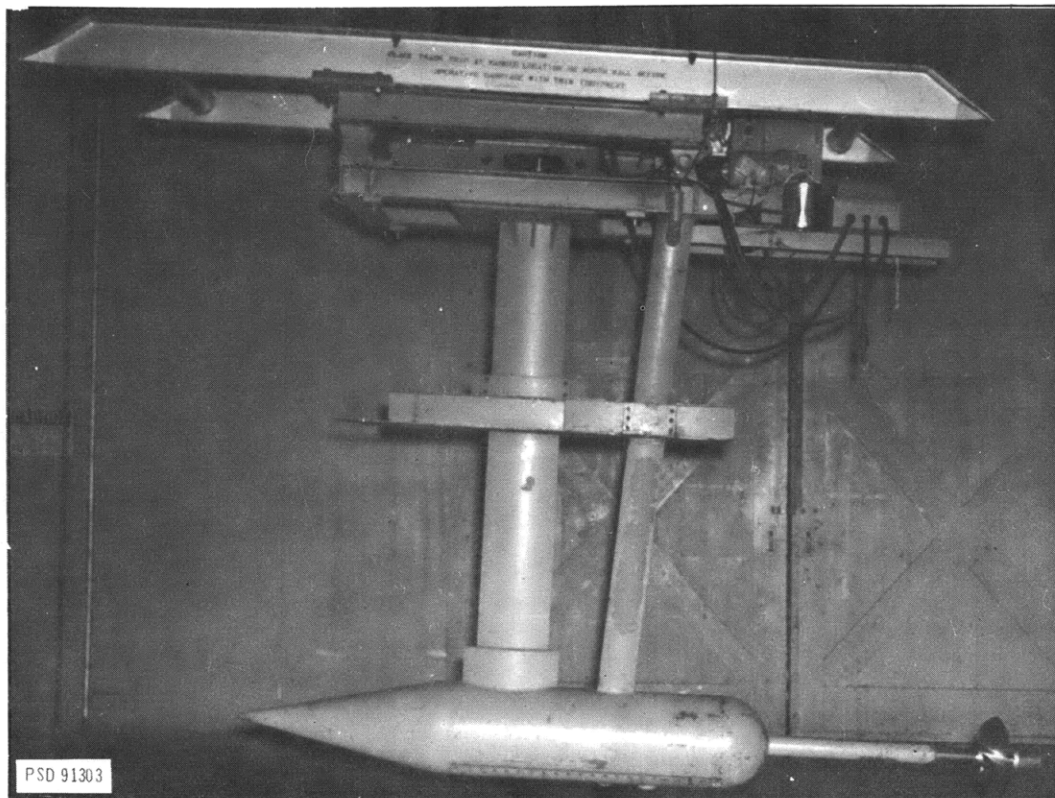

Figure 10 – 35-Horsepower Propeller Dynamometer

500-HORSEPOWER NACELLE DYNAMOMETER

This dynamometer, shown in Figure 11, is installed inside the nacelles of model hydrofoil boats and is used for measurement of torque, thrust, and rpm. A strut attached to a girder secured to the towing bridge supports the nacelle. The dynamometer is driven by a motor located above water through a 1:2 speedup right angle gear box, a vertical shaft, and a right angle gear box located in the nacelle; see Figure 12.

Magnithrust and magnitorque transducers of the differential reluctance type, described previously, are used on this dynamometer also. The dynamometer capacities are 3000 lb-in. of torque, 2000 lb of thrust, and 10,000 rpm, maximum.

GENERAL PURPOSE DYNAMOMETERS

Several propulsion dynamometers of the transmission type are available for surface and submerged model tests in the high-speed basin. Table 1 lists the capacities of a few of these

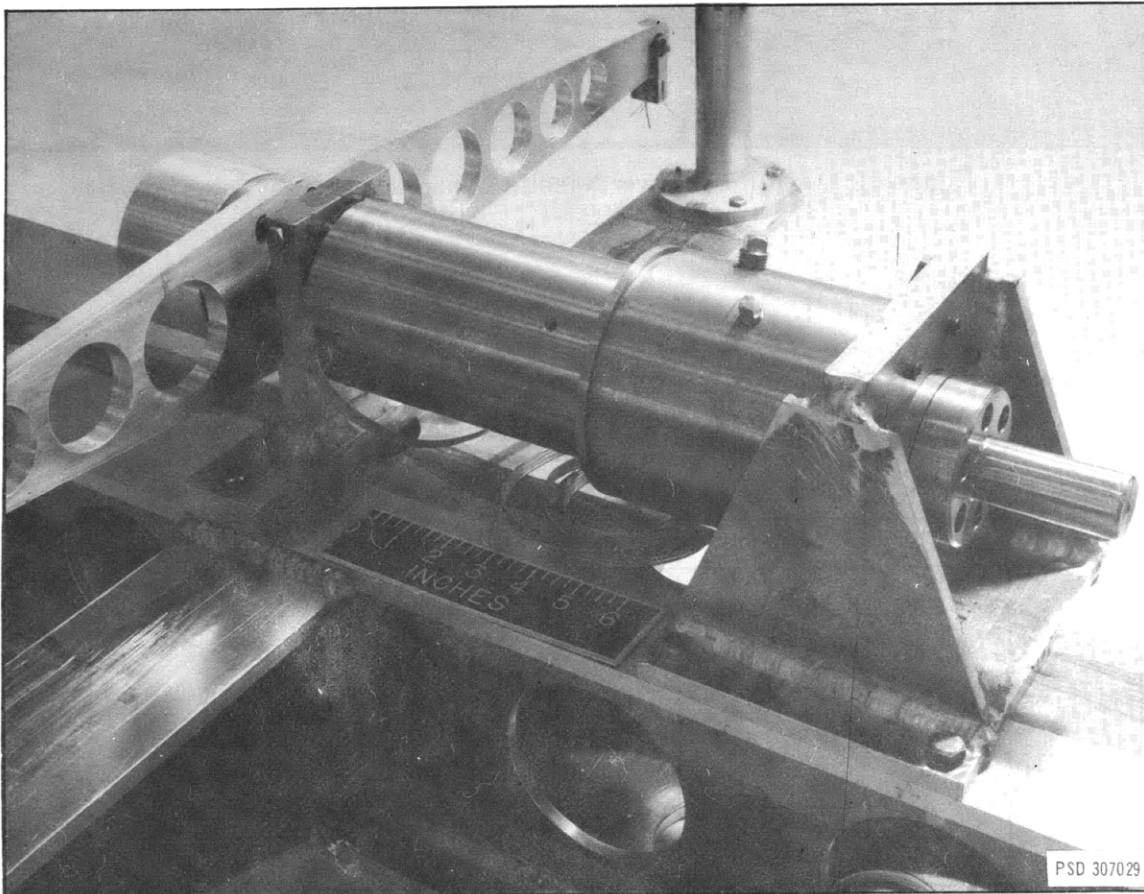

Figure 11 – 500-Horsepower Nacelle Dynamometer in Calibration Stand

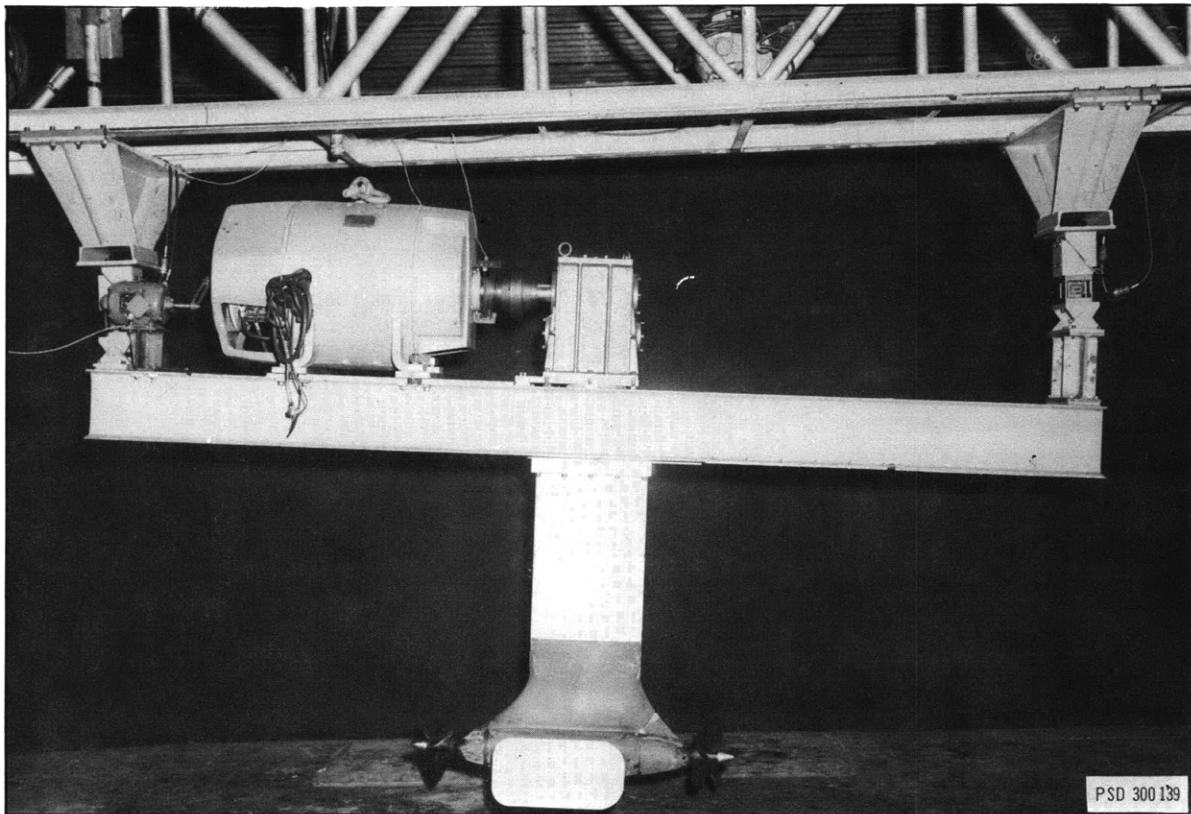

Figure 12 – 500-Horsepower Nacelle Dynamometer Test Setup

TABLE 1
Capacities of Some Transmission-Type
Propeller Dynamometers

Dynamometer	Thrust, lb	Torque, lb-in.	RPM
5 hp, 40 lb-in. torque	± 60	± 40	8500
5 hp, 50 lb-in. torque	± 50	± 50	5400
8.5 hp, 100 lb-in. torque	± 100	± 100	5400
5 hp, 150 lb-in. torque	± 150	± 150	5400
5 hp, 50 lb-in. torque (contrarotating)	± 50	± 50	5400
20 hp, 400 lb-in. torque	± 250	± 400	3600

dynamometers, and Figure 13 shows a typical propeller dynamometer connected to a propulsion motor. The outer diameter of the cylindrical portion is 2 5/16 in.; the overall length of the housing is 11 1/4 in. The essential parts of this dynamometer are shown in the exploded view, Figure 14.

INTERNAL RESISTANCE DYNAMOMETERS

Two dynamometers are available to measure the drag of full-scale or model torpedoes and of similar bodies. These dynamometers also utilize magnigage transducers installed between the end of a strut connected rigidly to the carriage and the model. Output is recorded on a digital recorder⁷ located on the carriage. The capacities of these dynamometers are 15⁰ lb and 4000 lb, respectively; see Figure 15.

HYDROFOIL DYNAMOMETER

The hydrofoil dynamometer is used to measure forces and moments acting on hydrofoils towed in a straight line at various angles of attack. The dynamometer is attached to the tow bridge on Carriage 5, as shown in Figure 16.

The dynamometer incorporates modular force gages with magnigage-type transducers as the measuring elements. Each unit is in the form of a 4-in. cube; see Figure 17. The gages are sensitive to forces in one direction only and when properly orientated and combined, can measure the forces and moments on the hydrofoil. The capacities of this dynamometer are:

Lift	5000 lb	Pitching moment	40,000 lb-in.
Drag	1000 lb	Rolling moment	40,000 lb-in.
Side Force	1500 lb	Yawing moment	20,000 lb-in.

Since modular force gages are available in capacities up to 2000 lb it is possible to vary the range of operation of the dynamometer by using modular force gages of different ranges.

INDUCTION MOTOR DYNAMOMETERS

Induction motor dynamometers of the cradle-frame type are available for calibrating large propulsion motors, such as those used for full-scale torpedoes; see Figure 18. This type of dynamometer gives torque as a function of the electrical current. From the calibration, the torque required to drive torpedo propellers can be determined by measuring the current input to the motors during model tests. The shaft horsepower can then be calculated from the torque values plus the measured shaft rpm.

The dynamometer consists of two 400-hp induction motors that can be used as generators to absorb power or as motors to deliver power. Toledo scales measure the forces acting

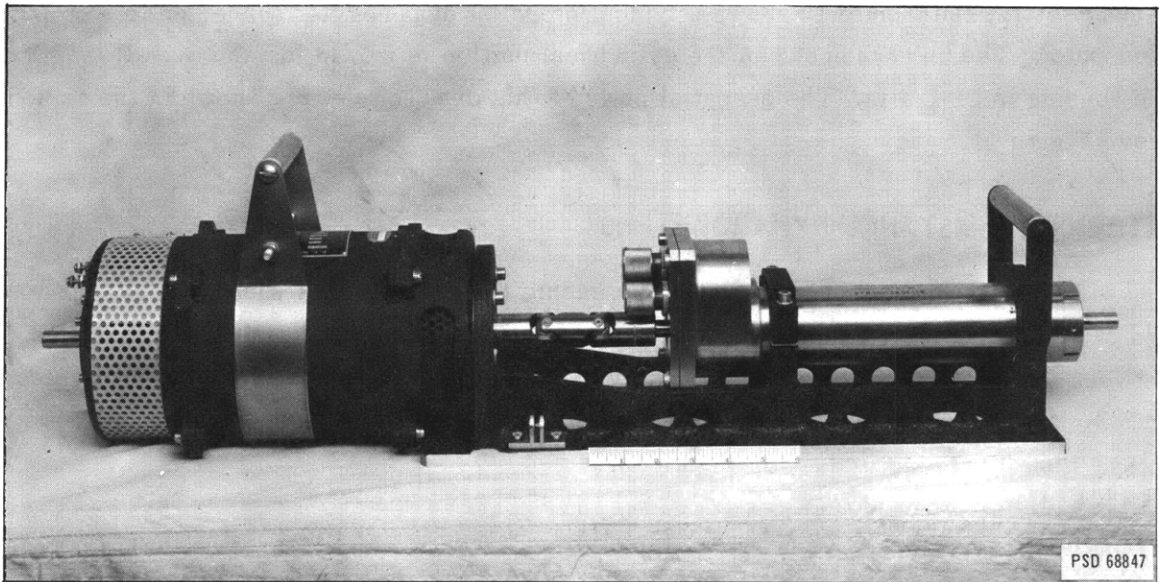

Figure 13 – 5-Horsepower, 100-Pound-Inch Propeller Dynamometer and Motor Ready for Surface Model Installation

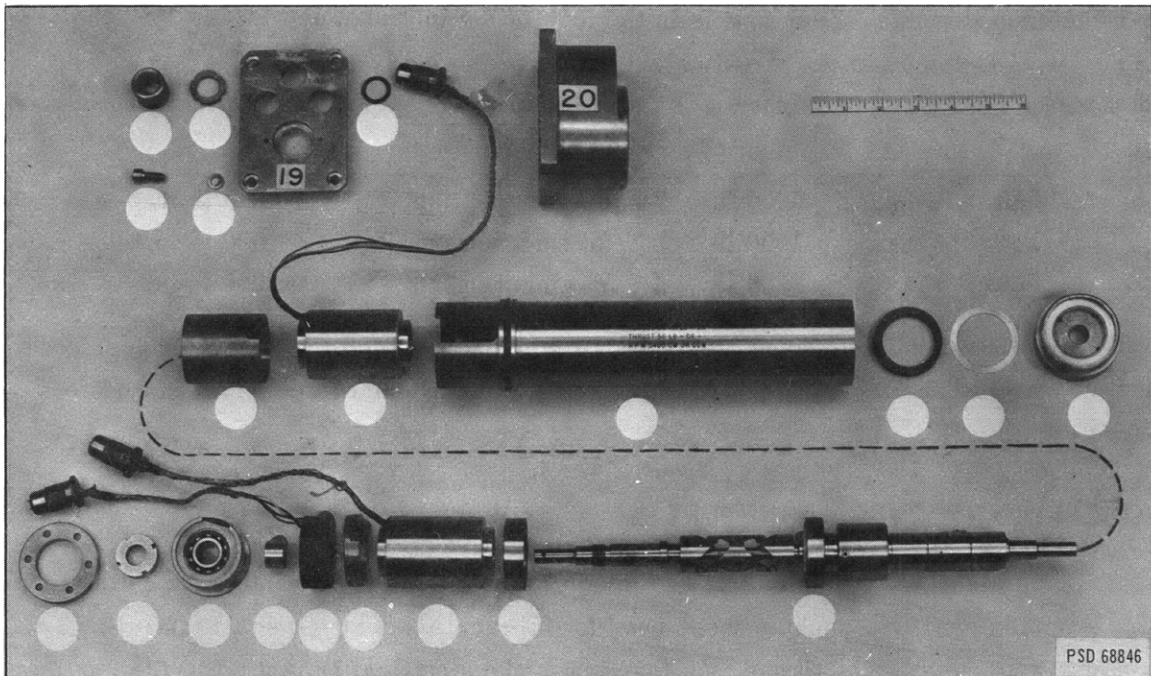

Figure 14 – Exploded View of 5-Horsepower, 50-Pound-Inch Propeller Dynamometer

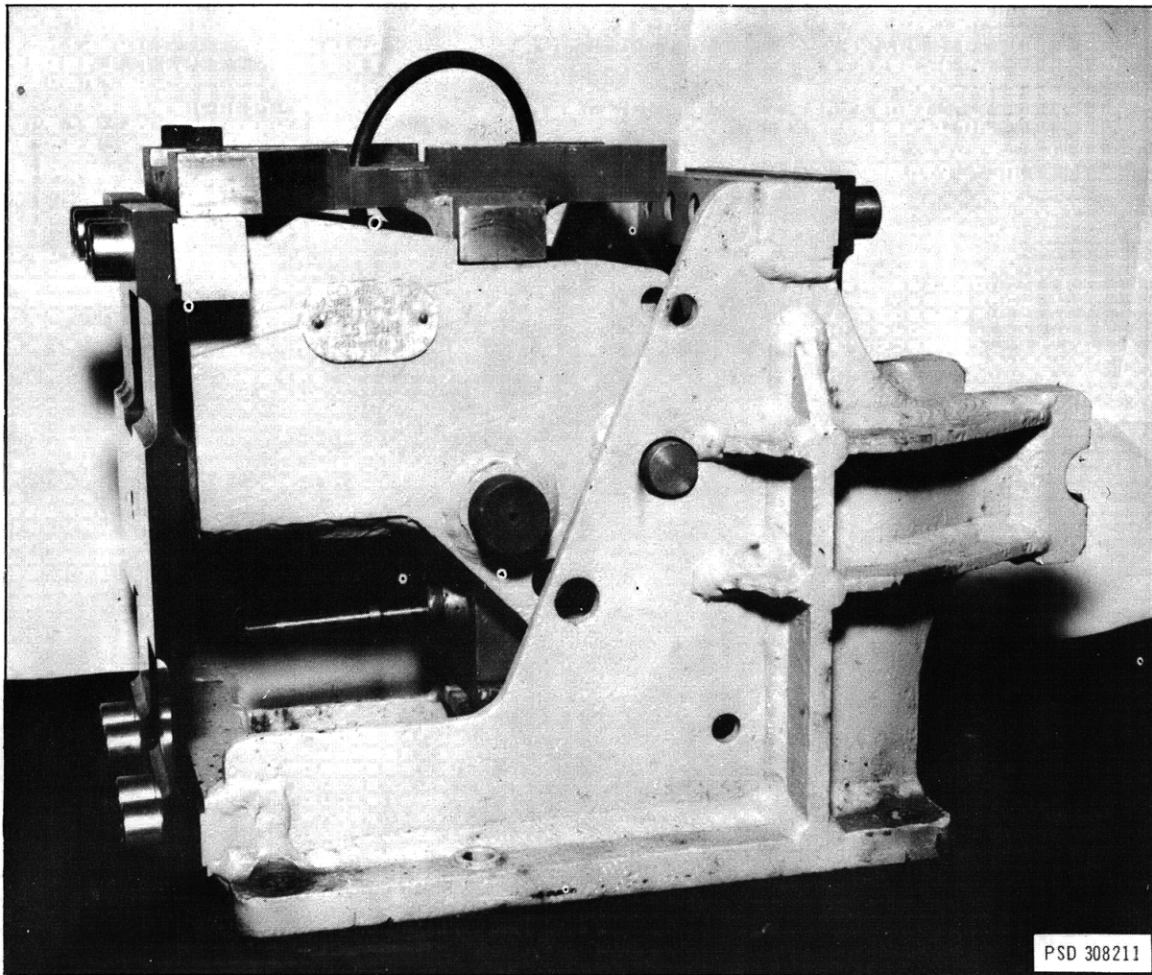

Figure 15 – 4000-Pound Internal Resistance Dynamometer

at the end of the torque arms. The motors and shafts are arranged so that contrarotating propeller motors can be simultaneously calibrated at ratings up to 400 hp each. If more than 400 hp is required, the dynamometer shafts can be coupled together to deliver or absorb 800 hp. The 400-hp induction motors are each rated at 265 amperes, 800/1065 volts, and 3000/4000 rpm.

The dynamometer has five scale ranges, and accuracies of 1/20 percent of scale range have been obtained under static conditions.

In addition to the 400-hp dynamometer, a 25-hp induction motor dynamometer of the cradle type is available for calibrating smaller propulsion motors. The small dynamometer, which consists of two 25-hp induction motors, has the same operating flexibility as the larger dynamometer.

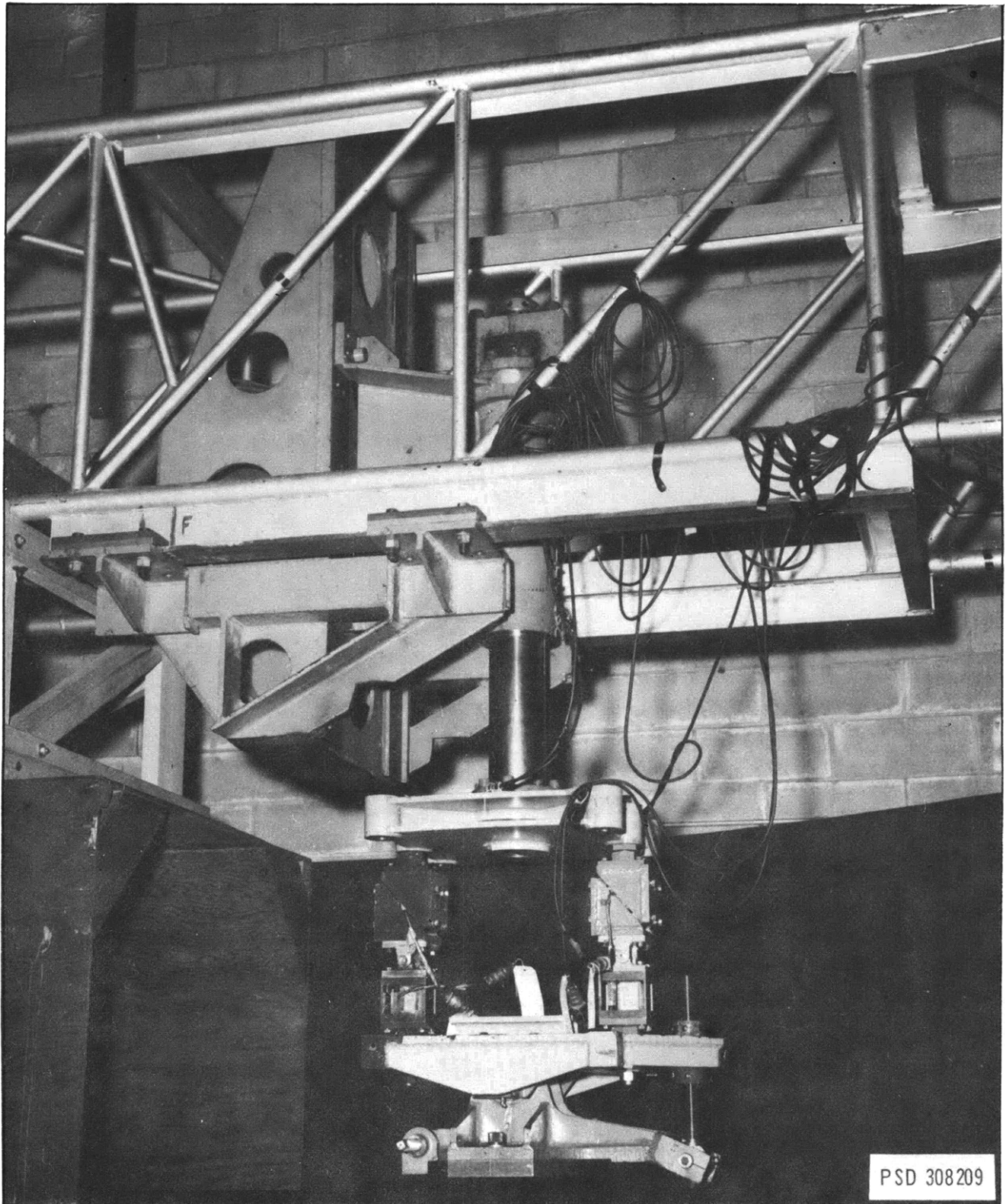

Figure 16 – Hydrofoil Dynamometer with Tow Bridge

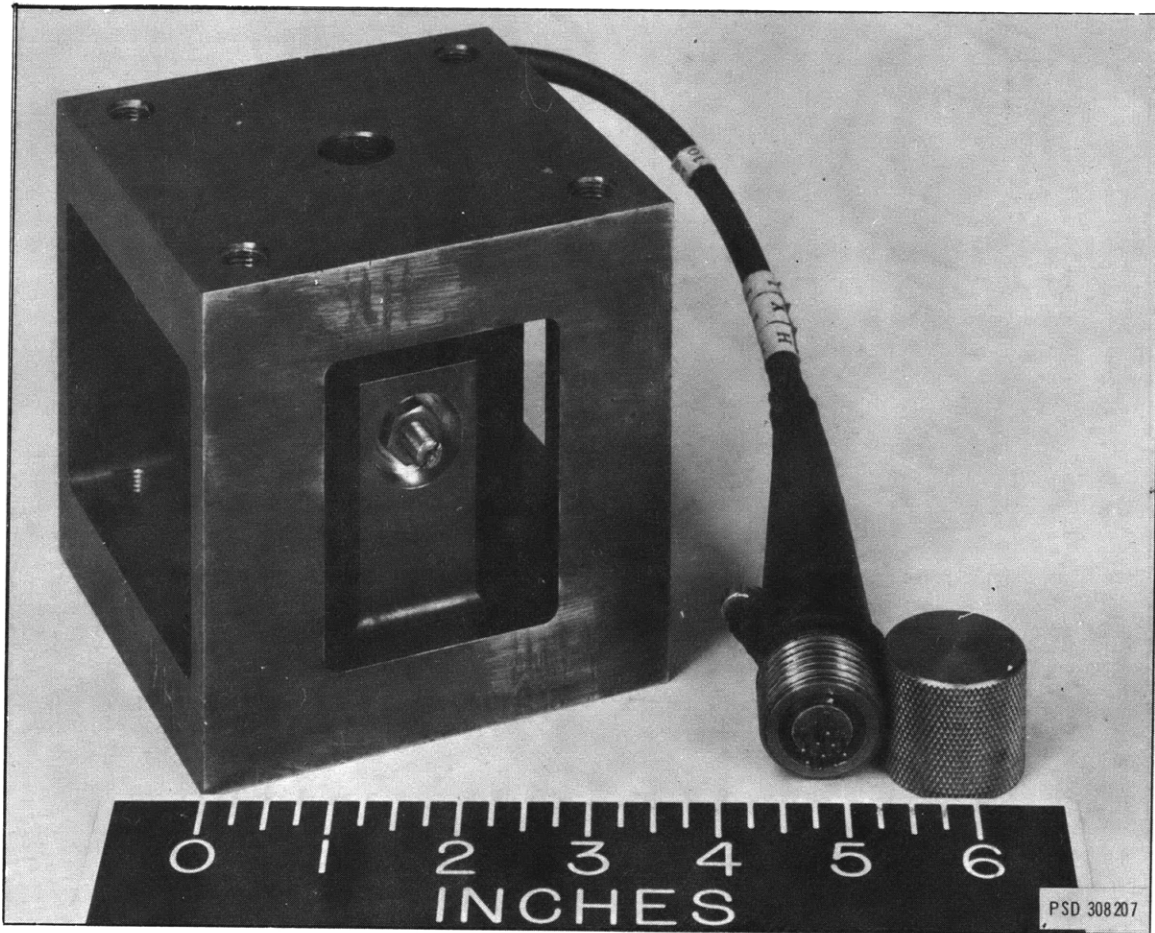

Figure 17 – Modular Force Gage

CARRIAGE SPEED MEASUREMENT

On Carriage 5, carriage speed is generally measured by means of an electromagnetic revolution counter. This counter consists of a steel idler wheel which is attached to the carriage and runs on the basin rails, a gear-toothed wheel, and a magnetic-type pickup that is actuated by the gear teeth. The system produces 100 pulses per feet of carriage travel. An electronic pulse counter and printer are used to indicate and record speed. Although this system is working satisfactorily, it is planned to install a higher resolution system in the near future which, by means of a rotopulser pickup, will record 1200 pulses per revolution.

Two speed-measuring systems are available on Carriage 3. One is an electromagnetic counter pickup system similar to that on Carriage 5. The other system, used in resistance tests of planing boats, records speed by measuring the distance between second marks scribed on a sensitized paper "card." This card is attached to a driven drum of 9.092-in. diameter which is geared to one of the carriage driving wheels so that a certain distance along the card corresponds to a given distance along the tracks. By means of a special scale, the carriage speed in knots may be read directly from the record.

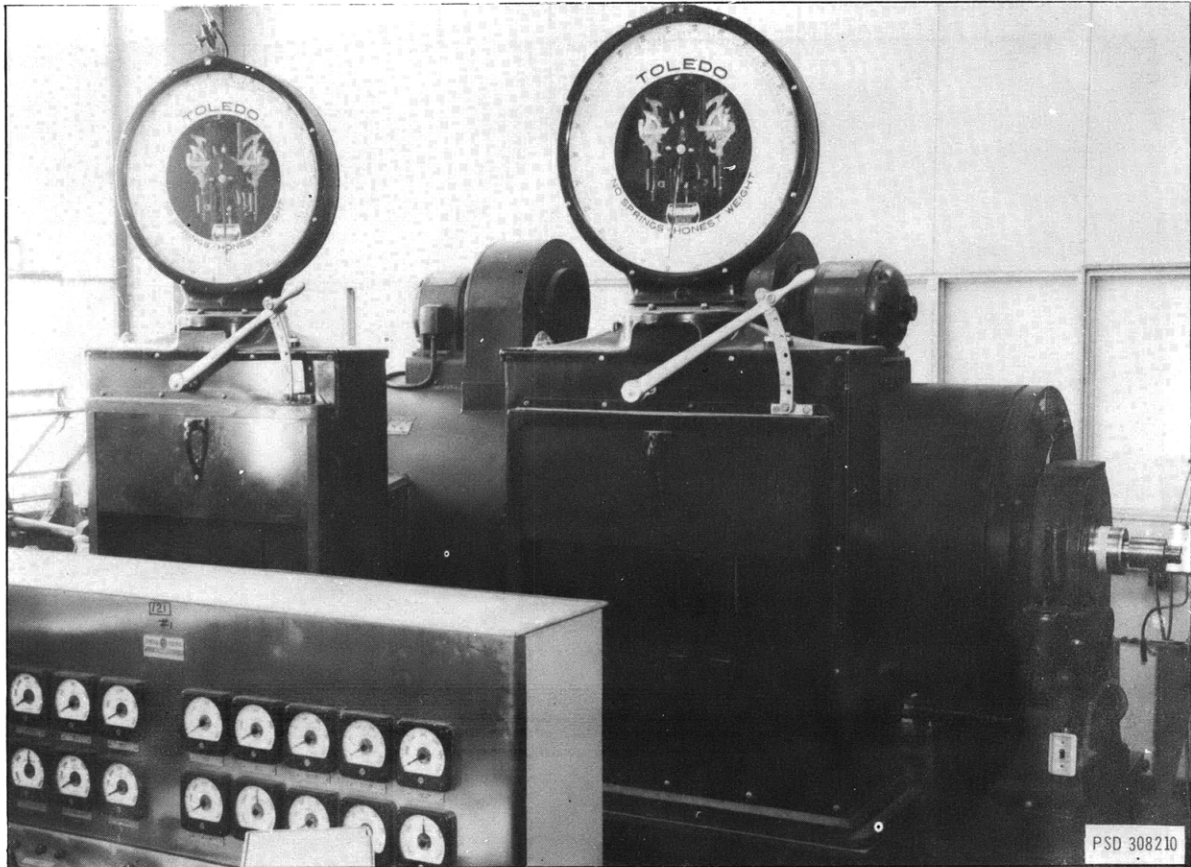

Figure 18 – 400-Horsepower Induction Motor Dynamometers

CARRIAGE 3 TOWING GEAR AND DYNAMOMETER

The resistance dynamometer on this carriage operates on the same principle as the dynamometers used on Carriages 1 and 2 serving the low-speed deep-water basins. The model is attached to the lower end of a pantograph frame with the other end of the frame fastened to a weight plus spring balance. The spring extension is recorded by a stylus that traces a line on a waxed paper card rolled onto a drum which serves also as a speed recorder, as described in the previous section.

Towing Gear No. 1 is an automatic towing device which moves up as the model rises so that the towing force is always supplied in the shaft line; see Figure 19. Towing Gear No. 2 is designed for testing planing surfaces and models of the hulls of seaplanes and hydrofoil boats; see Figure 20. Wing lift or hydrofoil lift are simulated by placing weight on a counterweight pan of Towing Gear No. 2. The drag force capacity of the towing gear is 150 lb.

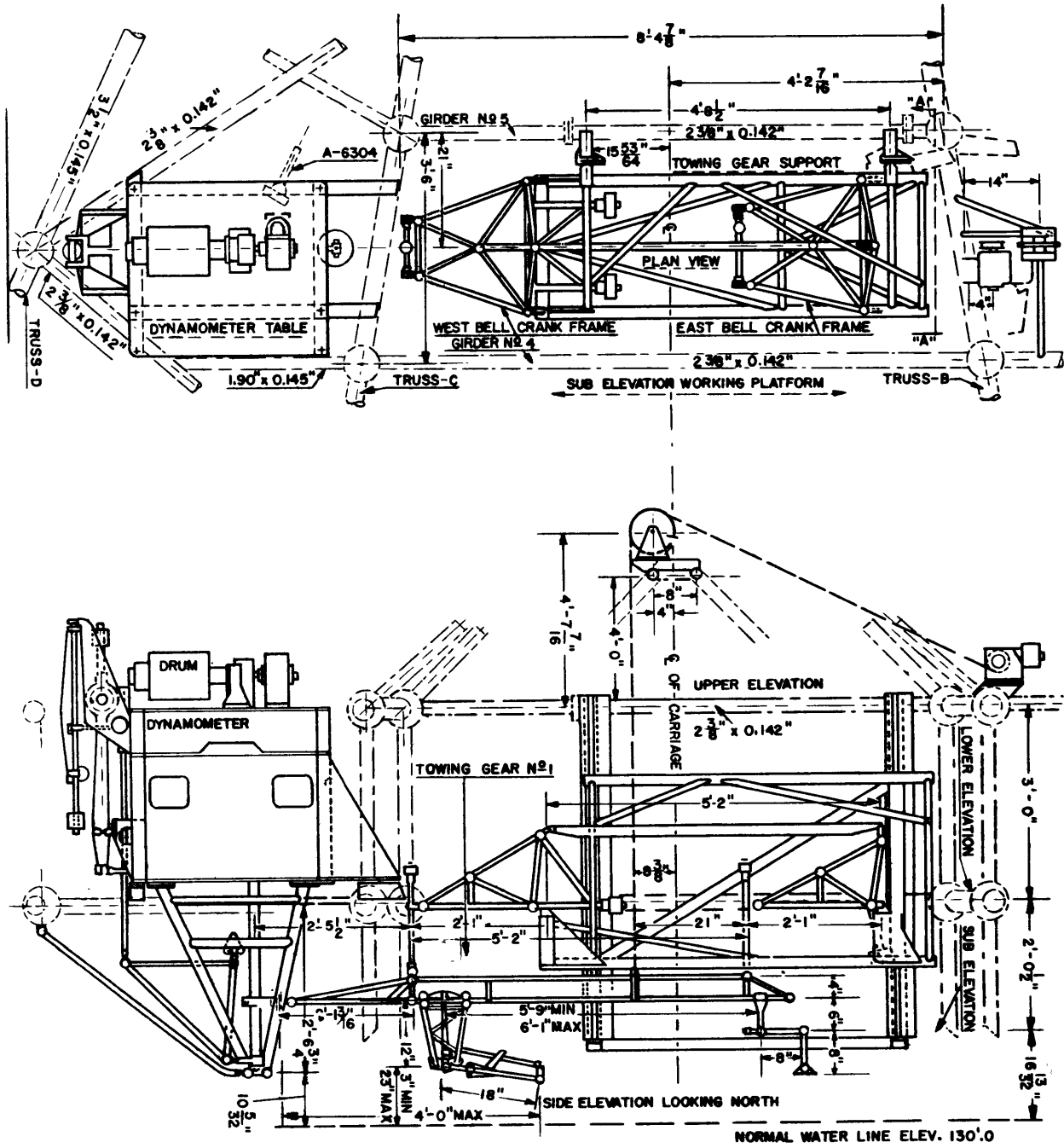

Figure 19 - Carriage 3 Dynamometer and Towing Gear No. 1

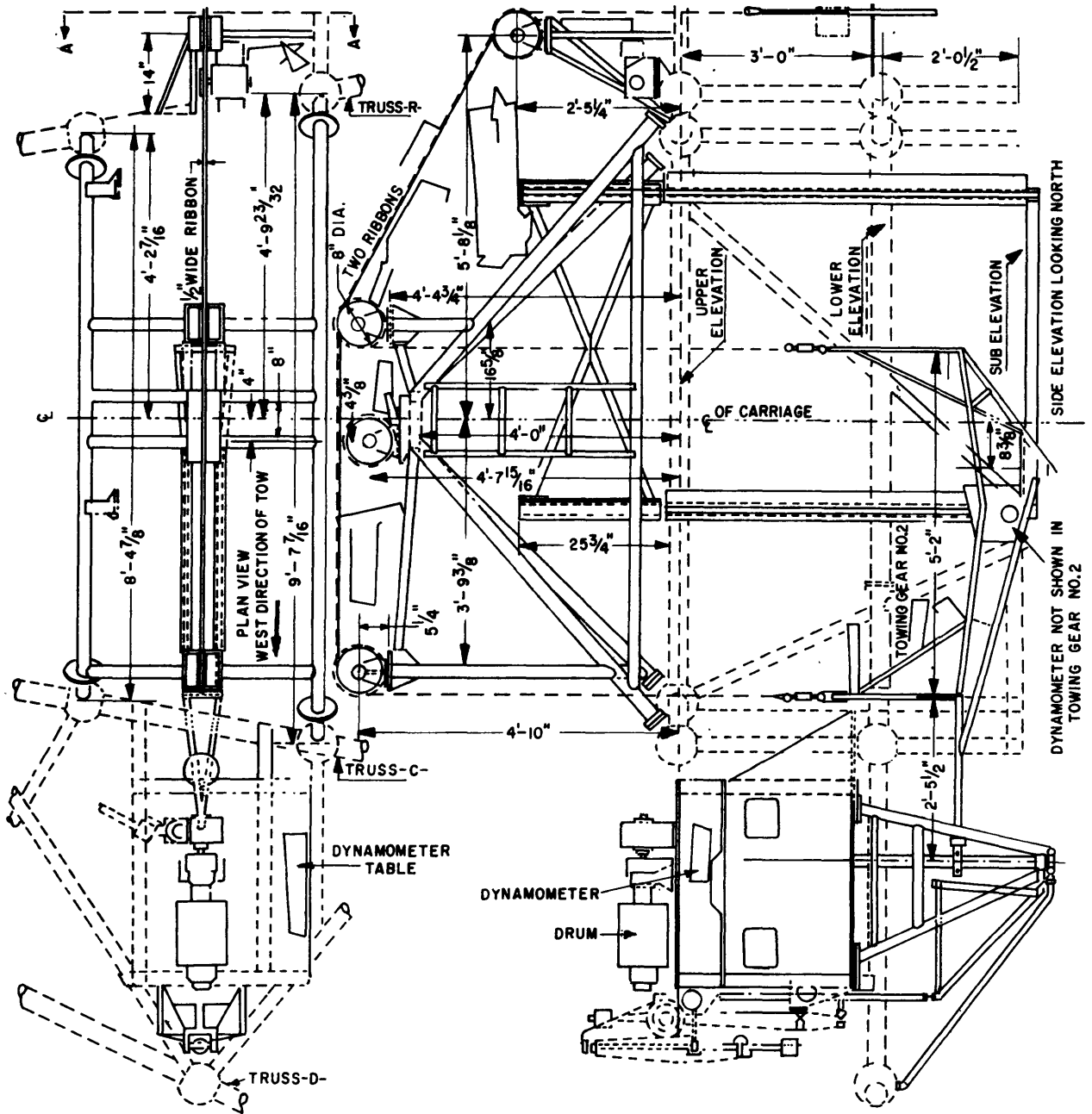

Figure 20 – Carriage 3 Dynamometer and Towing Gear No. 2

NEW INSTRUMENTATION

To carry out an extensive accelerated hydrofoil program in the high-speed basin, it is necessary to develop and procure additional major instrumentation involving expenditures of over one million dollars. A brief description of this instrumentation, which is nearing completion, follows.

PLANAR MOTION MECHANISM MK 2

This system is essentially a duplicate of the DTMB Planar Motion Mechanism Mk 1, described in detail in Reference 8, except that it is designed for the much larger loadings required by the higher tow speeds needed. It is a complete system for obtaining both static and dynamic stability coefficients from model tests. Briefly stated, to obtain the static derivatives, the test object is set at an angle to the flow and the forces and moments are measured. Dynamic coefficients are obtained by oscillating the body with forced frequency while the carriage is in forward motion and then recording forces, moments, and accelerations. Modular force gages of the differential reluctance type described previously are used to measure forces and moments. Readings are indicated digitally and recorded in tabular form by an electric typewriter; they can also be transcribed to IBM punch cards or recording tape. The system is designed so that all equipment, including the test model, may be installed in the bay of Carriage 5 as one complete package. This makes it unnecessary to delay the use of the carriage while preparing for a test.

The capacities of the system are impressed frequencies from 1/6 to 1/2 cps in five steps; heave amplitude ± 1 in.; pitch single amplitude 2 deg; roll single amplitude 2 1/2 deg. Force and moment capacities are as follows:

Lift	4000 lb	Roll Moment	650 lb-ft
Drag	4000 lb	Pitch Moment	10,000 lb-ft
Side Force	4000 lb	Yaw Moment	10,000 lb-ft

PITCH HEAVE OSCILLATOR NO. 2

This oscillator system will be used to determine experimentally the hydrodynamic conditions leading to the instability of hydrofoils in fully wetted, partially cavitating, or supercavitating flow. The unsteady hydrodynamic forces and moments will be measured by oscillating the foils in pitch and heave under a quiet water surface and under waves. The oscillator is driven by an electrohydraulic drive system.

A multi-channel digital data acquisition system will receive both analog and digital input signals and record them on magnetic tape in the proper format for direct entry into an IBM 7090 computer. The oscillator, including attached tow struts, foil, and the data acquisition system, will be installed as two packages in the open bay of Carriage 5.

The capacities of the oscillator system are: frequency range 0.05 to 15 cps continuously adjustable; heave amplitudes up to 0.5 in. single amplitude; pitch amplitude to 1 deg single amplitude; lift 35,000 lb; pitching moment 23,000 lb-ft. In addition to measuring overall forces and moments on the foil, stresses at various points in the foil will be measured by internally mounted strain gages.

1000-HORSEPOWER SUPERCAVITATING PROPELLER DYNAMOMETER

This dynamometer will be used in the high-speed basin on Carriage 5 to obtain propulsion characteristics of supercavitating propellers. The propeller will be sting-mounted at the forward end of a watertight torpedo-like nacelle which contains strain-gage-type dynamometer elements for measuring torque and thrust, propeller shafting, and propulsion motors. The nacelle will be connected to the towing carriage by a strut.

Two 500-hp d-c propulsion motors can be mounted in tandem inside the body. Digital instrumentation will be used for indicating and printing out on an electric typewriter the torque, thrust, and revolutions per minute. The capacities of this dynamometer are 8000 lb of thrust, 1050 lb-ft of torque, and 5000 rpm maximum.

WAVEMAKER AND WAVE ABSORBERS

A pneumatic-type wavemaker which may be installed at either end of the basin is also in the construction stage. Waves up to 40 ft in length will be generated. The wavemaker is similar in principle to those in the deep-water basin⁹ and in the maneuvering and seakeeping basin¹⁰ at the Taylor Model Basin.

Slope-type wave absorbers made up of rectangular precast concrete bar panels which rest on impermeable concrete panels will be installed at each end of the high-speed basin. These absorbers will reduce the reflections of the generated waves and thereby produce waves of desired purity of form.

UNDERWATER TV CAMERA AND HOUSING

A submerged watertight torpedo-like body which houses a Dage television camera and associated optical system will be used to observe test vehicle cavitation and other hydrodynamic phenomenon in the high-speed basin.

The housing will be attached to a strut which in turn is secured to Carriage 5. Electrical leads will feed through the strut to a control box and a 14-in. TV monitor mounted on the carriage. The designed underwater field of vision for the camera is 126 deg vertically and horizontally.

CONCLUSIONS

The high-speed basin with its associated instrumentation is an extremely versatile test facility for obtaining useful design data on the high-speed performance of underwater and surface test vehicles in still and rough water. By means of the instrumentation just described, numerous problems can be solved: directional stability and control of torpedoes, hydrofoils, and submarines; propulsion characteristics of propellers, torpedoes, pumpjets, and other underwater devices; resistance of planing and other high-speed craft; performance of hydrofoils under fully wetted, partially cavitating, ventilated, and supercavitating conditions; propeller "singing"; and other acoustic phenomena. The precision, size, and speed range of this facility make it unique in this country in that both model and full-scale testing of vehicles can be accomplished.

ACKNOWLEDGMENTS

The facilities and the instrumentation described in this paper are the result of the ingenuity, skill, and diligent work of many members of the Model Basin staff, of the Bureau of Ships, of the Bureau of Yards and Docks, and of many contractors. This is freely acknowledged by dedicating this paper to them. Permission granted by the Commanding Officer and Director of the Model Basin, Captain J.A. Obermeyer, USN, to publish this paper is also gratefully acknowledged.

REFERENCES

1. Saunders, H.E., "The David W. Taylor Model Basin, Parts 1, 2, and 3," Transactions Society of Naval Architects and Marine Engineers (1938, 1940, 1941).
2. Wright, E.A., "New Research Resources at the David Taylor Model Basin," David Taylor Model Basin Report 1292 (Jan 1959).
3. DeShazer, G.A., "An Arc Welded High Speed Model-Towing Carriage," Design-for-Progress Award Program, James F. Lincoln Arc Welding Foundation (Jun 1947).
4. Norman, G.J., Wilson, M.W., and Bryant, F.B., "Propeller Dynamometer Instrumentation at the David Taylor Model Basin," David Taylor Model Basin Report 1068 (Jul 1956).
5. Wilson, M.W., "A Differential Reluctance Measuring System and Its Application to Model and Ship Testing," American Institute of Electrical Engineers Middle Eastern District Meeting Paper (Apr 1958).
6. Santore, G.L., "Dynamic Calibration of 35-HP Propeller Dynamometer," David Taylor Model Basin Report 805 (Feb 1952).
7. Pimlott, J.R., "The TMB Magnetic Micrometer MK II," David Taylor Model Basin Report 847 (May 1953).

8. Gertler, M., "The DTMB Planar-Motion-Mechanism System," Symposium on Towing Tank Facilities, Instrumentation and Measuring Technique, Paper No. 6, Zagreb, Yugoslavia (Sep 1959).

9. Brownell, W.F., Asling, W.L., and Marks, W., "A 51-Foot Pneumatic Wavemaker and A Wave Absorber," David Taylor Model Basin Report 1054 (Aug 1956).

10. Brownell, W.F., "A Rotating Arm and Maneuvering Basin," David Taylor Model Basin Report 1053 (Jul 1956).

INITIAL DISTRIBUTION

Copies		Copies	
9	CHBUSHIPS 1 Lab Mgt (Code 320) 1 Pers & Fac Br (Code 322) 5 Tech Info Br (Code 335) 2 Prelim Des Br (Code 420)	1	Iowa Instit of Hydr Res, Iowa City
		1	DIR, Hydr Model Basin, University of Calif. Richmond, California
		1	O in C, PGSCOL, Webb
2	CHBUWEPS	1	Ord Res Lab, Pennsylvania State University
1	CDR, USNOTS, China Lake	1	University of Michigan, Exptl Nav Tank, Ann Arbor
1	CDR, USNOTS, Pasadena		
1	CO & DIR, USNRDL, San Francisco, Calif	1	Beth. Steel Co., Shpbldg. Div.
1	CO, USNTS, Keyport, Washington	1	Bolt, Beranek & Newman, Cambridge
1	CO, USNUOS	1	Gibbs & Cox
1	CDR, USNWEPLAB, Dahlgren	1	Kinlund & Drake, Naval Architects, N.Y.
1	CO & DIR, USNEL	1	Miami Shpbldg Corp
1	CO, USNMDL	1	Sun Oil Co., Philadelphia Shpbldg Div
1	DIR, SPECPROJOFF	1	Todd Shipyards Corp, Brooklyn
1	DIR, Hydr. Lab, NNSB & DD Co.	1	John Trumpy & Sons, Inc., Annapolis
1	EBD, Gyn Dyn Corp.	1	DIR, Towing Tank, CONVAIR Div of Gen Dyn Corp., San Diego
2	ADMIN, MARAD Attn: Off of Res & Dev	1	Grumman Aircraft Eng Corp., Bethpage, L.I., N.Y.
1	CDR, ARESDEVCOM, Andrews Airforce Base	1	California Institute of Tech, Hydro Lab, Pasadena
1	COMDT, USCG		
10	CDR, ASTIA		
1	DIR, Langley Res Ctr, NASA		
1	CO, USNROTCNAU, MIT		
1	Head, Dept NAME, MIT		
1	School of Nav Arch, MIT		
2	Davidson Lab, SIT		
1	University of California, Berkely Dept of Nav Arch		
1	University of Minnesota St Anthony Falls Hydr Lab		

MIT LIBRARIES

DUPL



3 9080 02754 4284

