

Report 1755

#1

MIT LIBRARIES



3 9080 02754 4615

V393
.R46



DEPARTMENT OF THE NAVY



HYDROMECHANICS

SIMULATION OF A LONG-CRESTED
GAUSSIAN SEAWAY



AERODYNAMICS

by

Michael C. Davis, LCDR, USN



STRUCTURAL
MECHANICS



APPLIED
MATHEMATICS



ACOUSTICS AND
VIBRATION



HYDROMECHANICS LABORATORY
RESEARCH AND DEVELOPMENT REPORT

April 1964

Report 1755

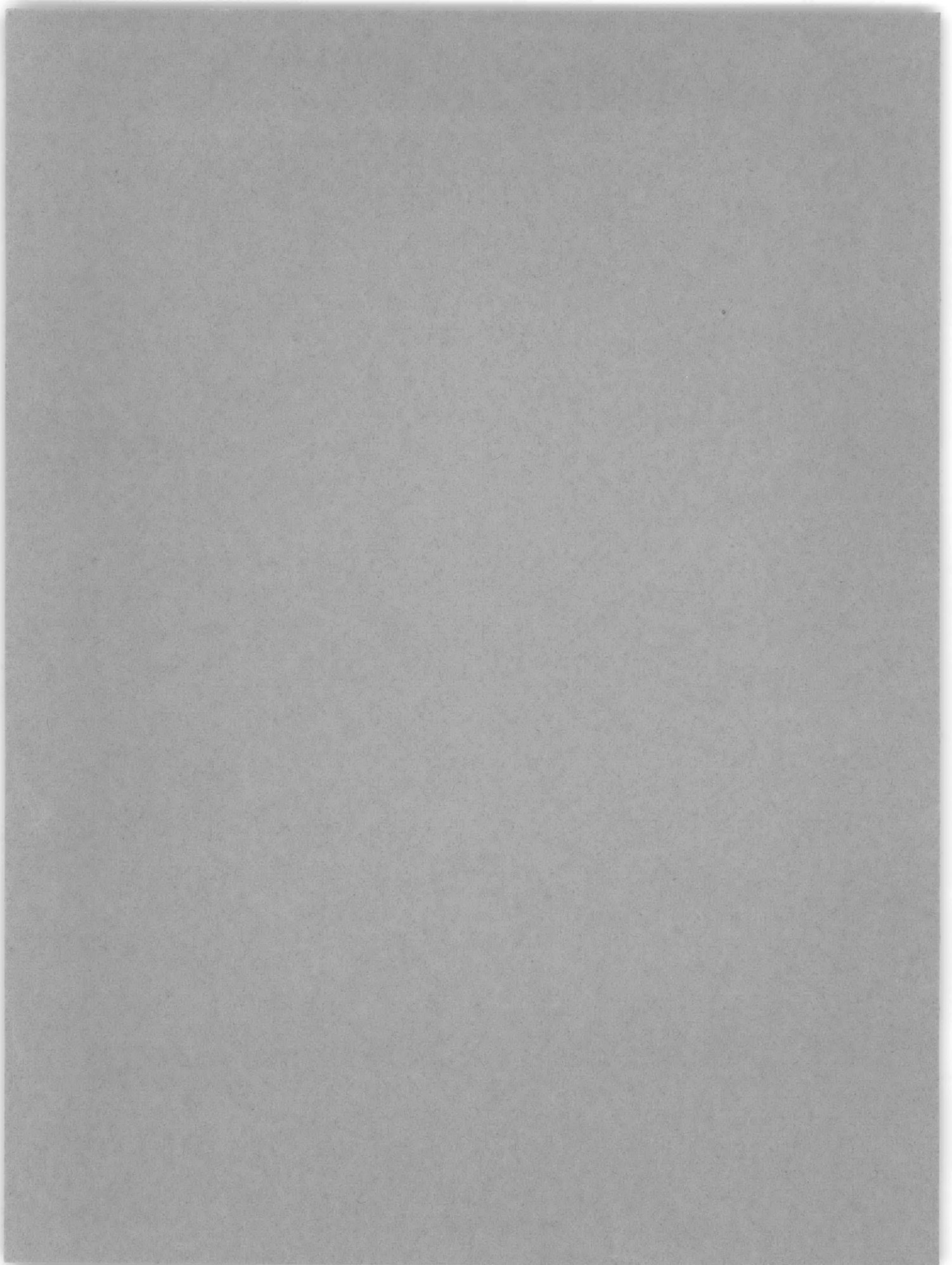

**SIMULATION OF A LONG-CRESTED
GAUSSIAN SEAWAY**

by

Michael C. Davis, LCDR, USN

April 1964

Report 1755

TABLE OF CONTENTS

	Page
ABSTRACT	1
INTRODUCTION.....	1
DESCRIPTION OF THE WAVEMAKING FACILITIES	1
DESIRED CHARACTERISTICS OF A SIMULATED SEAWAY	2
BASIC APPROACH	4
OUTLINE OF RESULTS	6
ANALOG PROGRAMMING TECHNIQUES	6
Synthesis of a Neumann Spectral Shape	9
Synthesis of Inverse Wavemaker Characteristics	10
DIFFICULTIES ENCOUNTERED IN WAVE GENERATION	12
SUMMARY OF INFORMATION GAINED FROM SPECTRAL PROGRAMMING.....	17
FUTURE DEVELOPMENT	17
Generation of a Family of Unidirectional Spectra	17
Approach to the Generation of Directional Spectra	18
ACKNOWLEDGMENTS	19
REFERENCES	19

LIST OF FIGURES

Figure 1 – Hydraulic Actuator Used to Control Flow of Air to Wavemaker Dome.....	3
Figure 2 – Frequency Response of Actuator Wavemaking System as Determined from Sinusoidal Excitation	5
Figure 3 – Irregular Long-Crested Waves Produced by Hydraulically Controlled Wavemakers	7
Figure 4 – Typical Wave-Height Recording of Neumann Spectral Simulation with Peak Frequency at 0.3 CPS	8
Figure 5 – Spectral Analysis of Waves Produced with Actuator Installation to Simulate Neumann Spectrum with Peak Frequency of 0.3 CPS	8

	Page
Figure 6 – Spectral Analysis of Waves Produced with Actuator Installation to Simulate Neumann Spectrum with Peak Frequency of 0.65 CPS	9
Figure 7 – Neumann Spectrum Normalized with Respect to Frequency and Amplitude of Peak	10
Figure 8 – Frequency Response of Linear System Synthesized on Analog Computer in Order to Insert Frequency Weighting of Neumann Spectrum with Peak Frequency of 0.3 CPS	11
Figure 9 – Frequency Response of Linear System Synthesized on Analog Computer in Order to Remove Measured Frequency Response Characteristics of Wavemaking System ..	11
Figure 10 – Analog Computer Configuration Used to Insert Proper Spectral Characteristics into Wavemaker Excitation Signal	13
Figure 11 – Spectral Analysis of Signal from White Noise Generator with 30-Minute Recording Time	14
Figure 12 – Spectral Analysis of Waves Produced with Actuator Installation to Simulate Neumann Spectrum with Peak Frequency of 0.5 CPS	15
Figure 13 – Change in Wave Spectral Shape Because of 50-Percent Reduction of Excitation Level of Actuators Using Input Program with Flat Frequency Characteristics	15
Figure 14 – Change in Wave Spectral Shape Because of 20-Percent Reduction in Air Blower Speed Using Input Program with Flat Frequency Characteristics	16
Figure 15 – Change in Wave Spectral Shape as a Function of Location in the Test Basin Using Input Program with Flat Frequency Characteristics	16
Figure 16 – Relation among Peak Frequency of Neumann Spectrum, RMS Wave Height, Model Scale Ratio λ , and Sea State for Simulated Long-Crested Seaways in the Test Basin.....	18

ABSTRACT

This report concerns the realistic simulation of irregular long-crested seas in the Harold E. Saunders Maneuvering and Seakeeping Facility. Random Gaussian seaways which approximated the Neumann spectral shape were produced for model testing by use of an electrohydraulic control system for wave generation. Techniques and difficulties associated with the use of an analog computer for wavemaker control are discussed. Plans for further development and extension to directional sea simulation are presented.

INTRODUCTION

In recent years the seaworthiness characteristics of ship designs have become increasingly important. The unsolved scientific problem of explaining the behavior of a ship in a heavy seaway is exceedingly complex and involves the interaction of a body free to move in six degrees of freedom with a randomly disturbed water surface. The associated problem of designing a hull form with specified seakeeping qualities is even further from complete solution.

Testing of scale models in waves has provided a fruitful means for investigating these problems. Essentially two paths have been followed:

1. The ship is characterized as a linear system responding to the various sinusoidal increments in the wave pattern, often through motion response tests in regular or pure sinusoidal waves.
2. The ship model is operated in a controlled wave environment which is structured to simulate conditions found at sea, and the linear approximation is evaluated along with various nonlinear phenomena such as slamming, shipping water over the deck, and extreme motions.

This report is concerned with the second type of seaworthiness testing as conducted at the David Taylor Model Basin, utilizing the new Harold E. Saunders Maneuvering and Seakeeping Facility (MASK) to simulate a random seaway. More specifically, the report presents the results obtained in an exploratory program of wave generation together with plans for future development.

DESCRIPTION OF THE WAVEMAKING FACILITIES

A complete description of MASK has recently been presented by Brownell.¹ Basically, the test basin is 360 ft long, 240 ft wide, and 20 ft deep; it has an array of pneumatic wave-makers along two adjacent sides and two wave-absorbing beaches along the other sides.

¹References are listed on page 19.

A 230-ton bridge spans the length of the basin and provides for rotation of up to 45 deg to allow model testing in a complete range of oblique waves. The 15-knot carriage which traverses the bridge structure carries instrumentation for measuring and recording the dynamic phenomena associated with a test on an attached free-running model.

Waves are generated by varying air pressure in a line of enclosed domes along the side of the basin. Thirteen such domes (each 25 ft long) are along the long side, eight along the short bank. Air for each dome is supplied separately by 100-hp blowers and controlled by flapper valves which alternate the flow of air to and from the domes. At the most efficient operating frequency, this system is capable of generating regular waves up to 24 in. (peak-to-trough) in height.

The present installation has two methods for controlling the wavemaker flapper valves and the resulting generated waves. The long bank of wavemakers is ganged together mechanically on a single shaft which rotates at a (constant or varying) programmed speed and produces a regular or a "quasi-random" wave train. A similar arrangement can be used along the short bank or, alternately, eight separately controlled electrohydraulic servo actuators are available for positioning the wavemaker flapper valves. It is this latter system (shown in Figure 1) which was used in the sea simulation described in this report.

Each of the eight hydraulic servos will control the angle of an air-controlling flapper valve so as to follow a voltage command signal from the wavemaking control station. These voltage command signals can originate from separate channels of an installed 14-track tape recorder, from a single such channel, or from low-frequency sinusoidal signal source.

DESIRED CHARACTERISTICS OF A SIMULATED SEAWAY

In attempting to make the most accurate simulation possible of a random seaway, naval architects are limited by the amount of statistical knowledge available to characterize actual ocean behavior. Assuming a linear wave theory, the most complete (and the only adequate) description of a wave system is the directional spectrum of the sea, which is a measure of the amount of average energy contained in each incremental wave length traveling in each incremental direction. Unfortunately, very little is currently known of the directional distributions of waves at sea although oceanographers are now working extensively in this area.

One characteristic of wave measurements which are made at sea is the type of randomness encountered. With the wave system created under wind action which acts on the surface in incremental gusts spread over a large area, it is reasonable to assume that the motion of the surface is closely approximated by a Gaussian random process, a type which is often encountered in physical applications and which contains the "most randomness" for a given level of disturbance. Experimental measurements support this assumption.²

Even if all waves in a seaway appear to come from a single direction, or nearly so, there is no general agreement among oceanographers as to the distribution of average energy

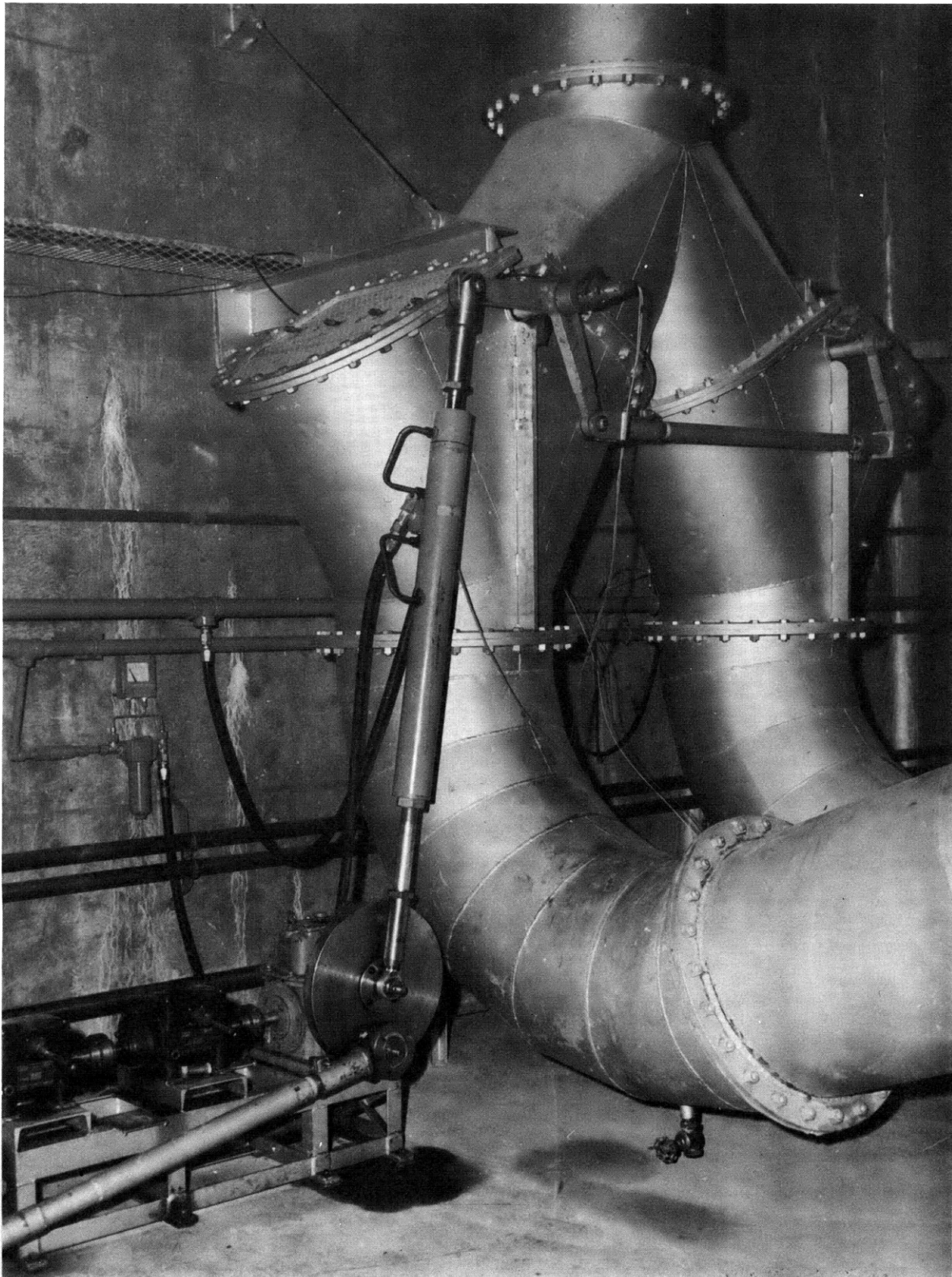

Figure 1 – Hydraulic Actuator Used to Control Flow of Air to Wavemaker Dome

in each wave length, or alternately, in each frequency band. Some general trends have been universally observed, however; for instance, when the sea disturbance becomes higher, the waves tend to become longer. One analytical form which is often quoted, probably because of its age rather than its close approximation to reality, is the Neumann spectrum of the form $(C_1/\omega^6) \exp(-C_2/\omega^2)$, where ω is the frequency of the incremental wave component measured at a point and C_1 and C_2 are constants.

In selecting a goal for simulation in the Model Basin facility, it was first specified that a Gaussian random process be generated. Next, for lack of a generally accepted theoretical form, it was decided to use the Neumann spectrum to adjust the relative weighting of power content in each frequency band. This choice is perhaps not a bad one since this smooth form results in a rather broad but grossly representative power distribution versus frequency and avoids extreme resonance effects which could result from a more narrow distribution interacting with the sharply tuned ship "system."

Obviously, it would be desirable to provide for directionality in the waves generated, as this is theoretically possible because of the independent control available for each of the eight wavemaking systems along the short side of the basin. However, it was felt that the initial work in this area should be confined to unidirectional or long-crested sea simulation in order to define and resolve the new problems anticipated with wave control using the hydraulic actuator system. The resulting long-crested waves would themselves be a very useful research tool, simulating rather well certain highly directional wave conditions at sea, and they might be expected to produce model motions generally representative of those observed at sea. In fact, one can argue that in certain cases it might be highly desirable to have long-crested waves in order to investigate nonlinear effects which are quite sensitive to wave direction.

In summary, the goal of this exploratory development of wave-generation procedures was to reproduce a long-crested Gaussian seaway with wave lengths distributed corresponding to the Neumann spectrum.

BASIC APPROACH

A very basic way of looking at the wavemaking operation is to consider it a "system" in the manner of the electrical engineer; that is, to consider as a "cause" the voltage signal which controls the hydraulic servo and as an "effect" the wave height that would be measured with a suitable transducer in the middle of the basin. To a first approximation, this system could be considered linear, based on earlier studies of regular waves which indicated a roughly straight-line relationship between wave amplitude and the rate of air flow to the domes.

A basic description of a linear system is its frequency response which, in this case, is a ratio of the wave height observed in the water to the sinusoidal voltage applied to the actuator controls. The first such measurement with the actuators (see Figure 2) was the starting point of the programming effort.

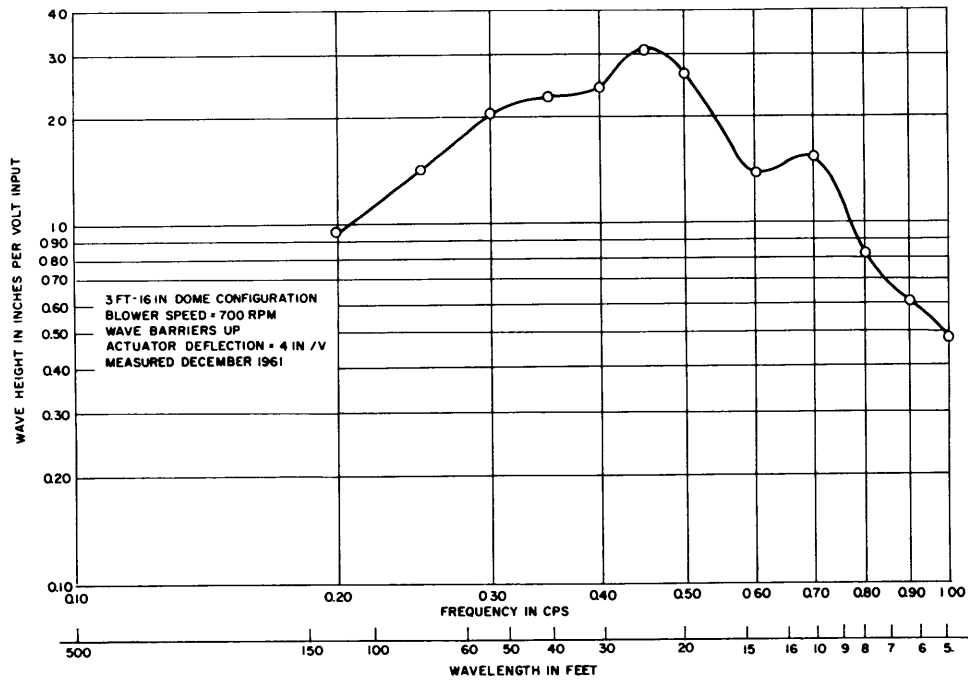

Figure 2 – Frequency Response of Actuator Wavemaking System as Determined from Sinusoidal Excitation

It is well known that the amplitude spectrum of a random process is multiplied by the square of the magnitude of the frequency response of a linear system through which the process passes. It was reasoned that if the voltage applied to the actuators had a power density spectrum with the desired Neumann shape, multiplied by a term inversely proportional to the square of the frequency response of the wavemaking system, the resulting wave height observed in the water would have the desired Neumann weighting. In other words, the characteristics of the wavemakers would be effectively cancelled out with the excitation signal.

The problem then becomes the generation and recording of a random voltage with the desired power density spectrum, i.e., the Neumann shape times the inverse wavemaker characteristics. Fortunately, this is a well-established technique in analog computer simulation developed for use in statistical studies of complex systems.

The standard source of randomness in the analog computation facility is the so-called “white noise” generator which produces a random signal with a relatively flat power spectral density over a large frequency range and which has the desired Gaussian characteristics. The steps in programming are:

1. A random noise source is used to excite a properly designed linear system on the analog computer, and the output of this system is recorded on magnetic tape.
2. This signal on magnetic tape is used to control all wavemaking systems in unison, creating a unidirectional random wave pattern.

If the relationship between waves measured in the water and voltage applied to the wavemaking servos is approximately linear, then the waves will represent a Gaussian random process since it is well known that a Gaussian signal passing through one or more linear systems remains Gaussian.

OUTLINE OF RESULTS

Initial programming for the wave spectra was completed in June 1962. After several programming corrections and retaping, successful spectra suitable for ship-model testing were created and measured in MASK in September 1962. Figure 3 shows a typical wave pattern in the basin. Figure 4 is a typical recording of the wave heights observed in the water. Figures 5 and 6 depict the result of a spectral analysis of two of the most successful wave programs plotted for comparison with the desired Neumann weighting of power.

It is obvious from these results that the basic goals of this exploratory wave-programming effort have been satisfied—the waves appear to the eye to be similar to those observed at sea, they are as close to a Gaussian random process as can be generated, and they have a controlled distribution of average energy in each band of wave lengths. As of January 1963, they had been successfully used in over 60 hours of model testing.

The remainder of this report discusses in some detail the programming techniques used and the difficulties encountered; it presents a plan for the development of a series of wave-generation programs which will meet the simulation needs for ship models in sea conditions up to State 7 severity as well as extending to the directional case.

ANALOG PROGRAMMING TECHNIQUES

As will be recalled, the development of the wave program required that a random voltage be recorded on magnetic tape which has a power density spectrum equal to the product of the Neumann spectral shape and the square of the inverse frequency-response characteristics of the wavemaker. From linear statistical theory, this spectrum will result from excitation of a linear system by a white noise generator if the linear system has a transfer function or frequency response equal to the square root of the Neumann spectrum multiplied by the reciprocal of the wavemaker frequency response. The programming or synthesis of the proper frequency characteristics of a linear system on an analog computer is logically divided into the following two parts which represent two linear systems in tandem.

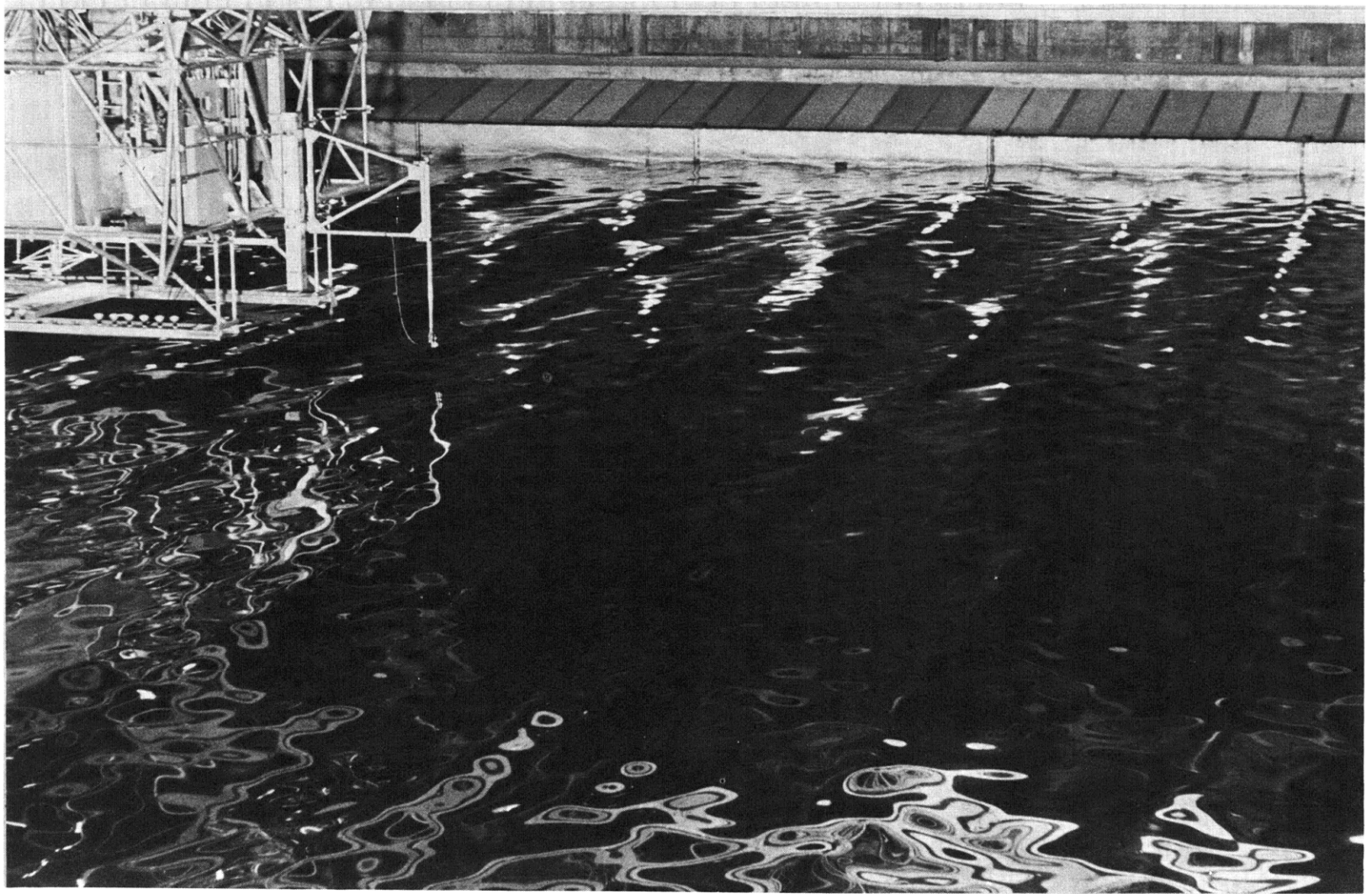

Figure 3 – Irregular Long-Crested Waves Produced by Hydraulically Controlled Wavemakers

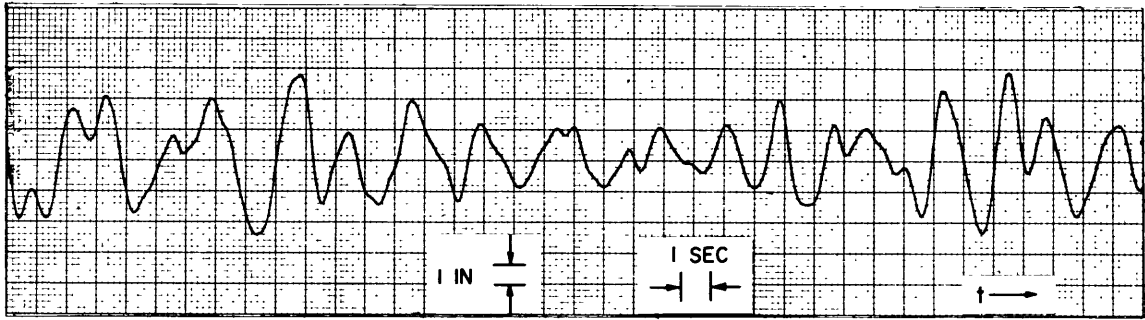

Figure 4 – Typical Wave-Height Recording of Neumann Spectral Simulation with Peak Frequency at 0.3 CPS

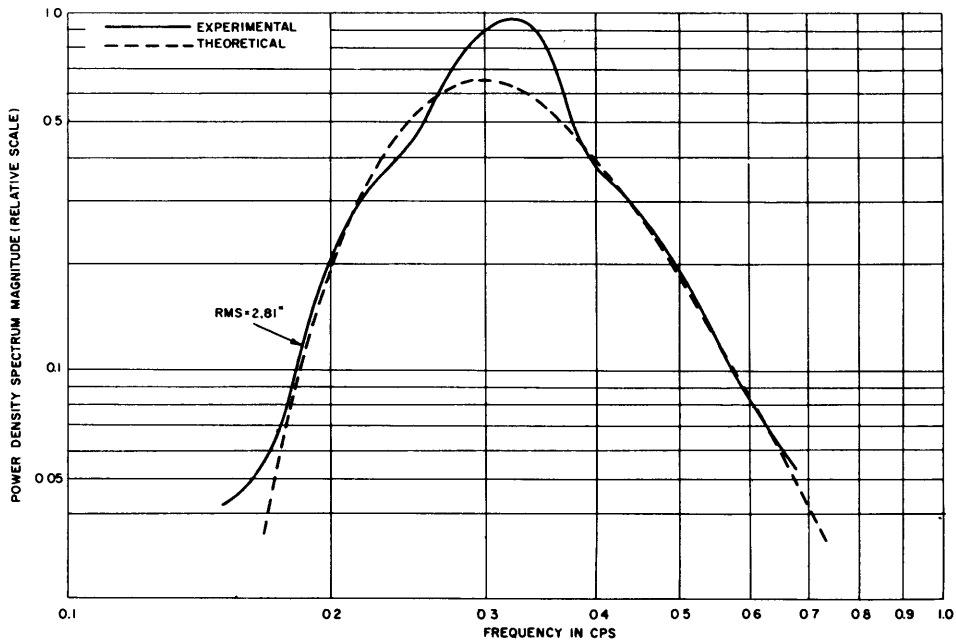

Figure 5 – Spectral Analysis of Waves Produced with Actuator Installation to Simulate Neumann Spectrum with Peak Frequency of 0.3 CPS

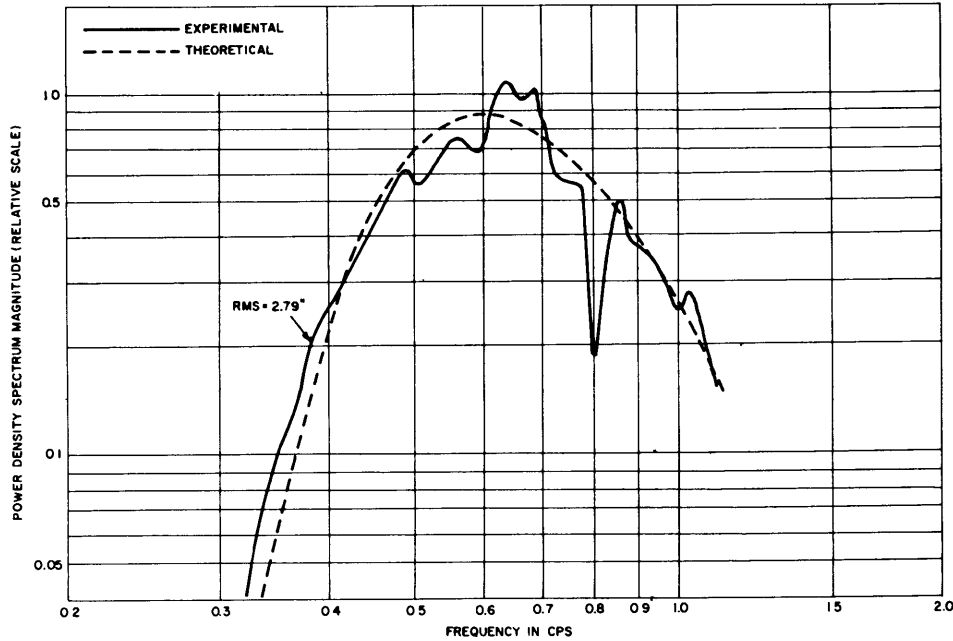

Figure 6 – Spectral Analysis of Waves Produced with Actuator Installation to Simulate Neumann Spectrum with Peak Frequency of 0.65 CPS

SYNTHESIS OF A NEUMANN SPECTRAL SHAPE

The basic building block of an analog computer is the integrator, with transfer function in the Laplace transform notation of $1/s$. Through proper interconnection of these elements, an overall transfer function can be synthesized which is the ratio of arbitrary polynomials in s , assuming that the degree of the denominator polynomial is not less than that of the numerator. The Neumann spectrum has the form $N(\omega) = (C_1/\omega^6) \exp(-C_2/\omega^2)$, which is certainly not suitable for direct simulation using the analog computer.

The Neumann spectrum has several interesting properties that are not readily apparent. Equating the derivative of the spectrum to zero, we find that the peak power density occurs at $\omega_p = \sqrt{C_2/3}$ with a value of $C_1 \exp(-3/\omega_p^6)$. Normalizing with respect to the peak value, we obtain $N(\omega)/N(\omega_p) = \{\omega_p/\omega\}^6 \{\exp[3]\} \{\exp[-3/(\omega/\omega_p)^2]\}$, which is only a function of the ratio of frequency to peak frequency. This indicates that if plotted on log-log graph paper, all Neumann spectra would have the same shape; and if normalized to the peak frequency and peak amplitude, they would plot on the same curve; see Figure 7. This suggests that a proper presentation of experimental sea spectra should be in logarithmic form for comparison with the Neumann hypothesis.

This normalization property of the Neumann spectrum also has significance for analog computer simulation. Because spectra should be provided over a range of peak frequencies in the basin to simulate various sea states, it is of considerable convenience that the shape

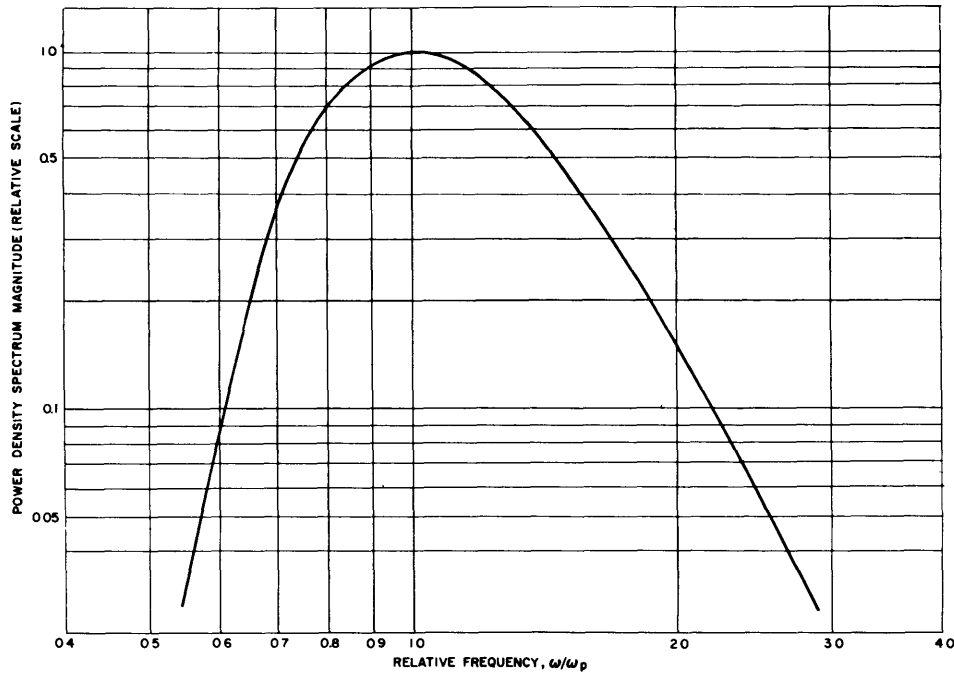

Figure 7 – Neumann Spectrum Normalized with Respect to Frequency and Amplitude of Peak

is a function only of ω / ω_p since knowledge of an approximate polynomial expression for a certain peak frequency spectrum automatically yields an approximation for all peak frequencies by making a suitable linear scale change in s .

By trial and error techniques common to the electrical engineer, a polynomial approximation was synthesized for approximating the square root of the normalized Neumann spectrum:

$$\frac{4.85 s^9 (s^2 + 0.0625 s + 0.199) (s + 1.385)}{(s + 0.533)^{12} (s^2 + 0.536s + 0.199) (s + 1.124)}$$

The frequency response (at $s = j\omega$) of this approximation is compared with the theoretical expression in Figure 8 and is seen to agree quite closely except at extremely low frequencies.

SYNTHESIS OF INVERSE WAVEMAKER CHARACTERISTICS

The inverse of the wavemaker frequency response (relating the wave height in the basin to a sinusoidal voltage applied to the wavemaking system) was approximated, again by trial and error methods, by a polynomial expression:

$$\frac{(s + 1.325)^2 (s^2 + 0.9s + 3.24) (s^2 + 0.295s + 8.71) (s^2 + 0.28s + 19.8)}{(s + 0.3)^2 (s^2 + 1.44s + 3.24) (s^2 + 0.502s + 8.71) (s^2 + 0.445s + 1.98)}$$

$$\frac{(s^2 + 2.87s + 33.1) (s^2 + 1.74s + 8.41)}{(s^2 + 4.14s + 33.1) (s + 20)^3 (s + 50)}$$

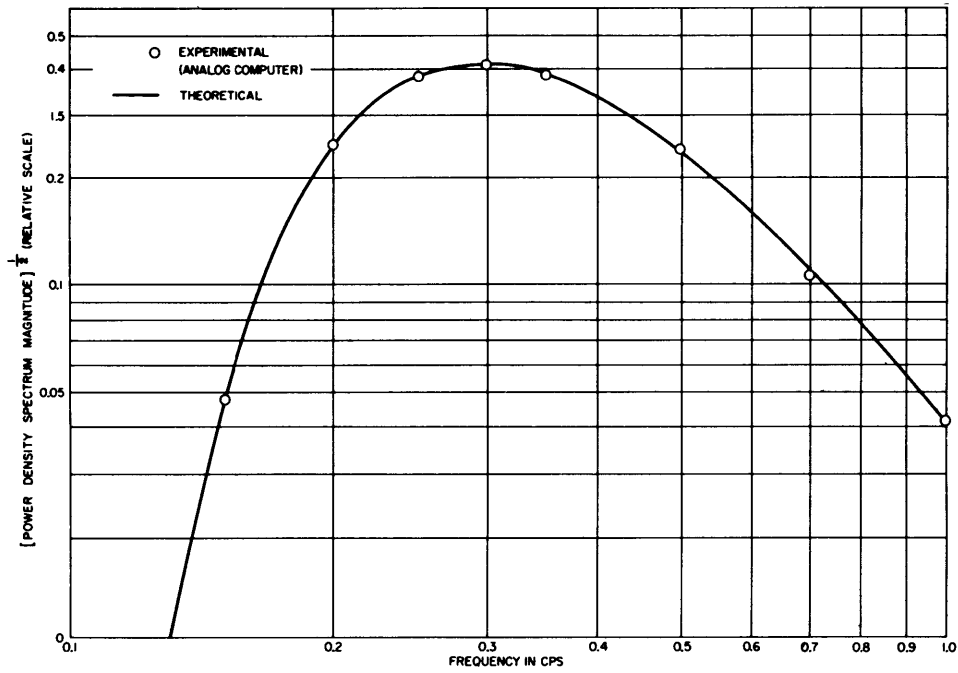

Figure 8 – Frequency Response of Linear System Synthesized on Analog Computer in Order to Insert Frequency Weighting of Neumann Spectrum with Peak Frequency of 0.3 CPS

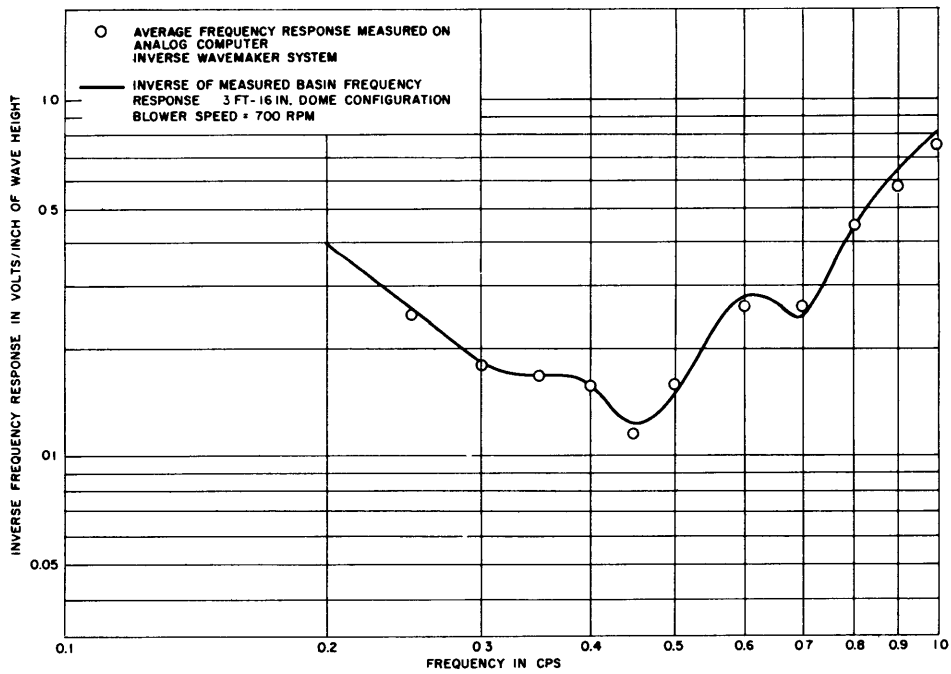

Figure 9 – Frequency Response of Linear System Synthesized on Analog Computer in Order to Remove Measured Frequency Response Characteristics of Wavemaking System

The complexity of this expression arose essentially from a desire to match every observed peak in the experimental frequency-response characteristics, as shown in Figure 9. In retrospect, it would have been better to use a much simpler approximation and to reserve a finer frequency correction for later application.

The overall analog computer configuration is pictured in Figure 10. It was excited by white noise generating a random voltage which was recorded on magnetic tape in order to control the wavemaker system.

DIFFICULTIES ENCOUNTERED IN WAVE GENERATION

Having fixed the desired relative distribution of wave height for each increment of frequency, there are two basic goals in optimizing the controlling program:

1. To raise the upper limit of average wave height which can be created in the basin. This is constrained by the allowable range of travel of the flapper valve in the wavemaker and by the maximum rpm (1500) at which the air-blower motors can be driven.
2. To obtain the specified distribution of wave height at each frequency.

Several deficiencies were obvious in the first set of programs developed in June 1962. The measured wave heights were much smaller than desired, the spectral distribution was greatly distorted, and the hydraulic servo systems were rate-saturated. It was immediately obvious from an examination of the spectrum of the taped excitation signal that a very considerable excess of power had been concentrated in the frequency range above 1 cps in order to compensate for the inefficient generation of waves at these frequencies. This excess energy was undoubtedly the reason for the observed rate saturation, and because of the nonlinear behavior, it contributed to the spectral deformation. Also, since the total power of a command signal determines the root-mean-square (rms) motion of the flapper valve, which cannot exceed a certain amount because of physical limitations on travel, this additional inefficient energy caused a large reduction in observed wave-height levels in the basin.

To lessen the effect of this undesirable high-frequency power, the programs were later operated on by a low-pass filter, which had a flat frequency response to 1 cps and a 160-db/decade attenuation thereafter, synthesized on the analog computer.

Still another correction was introduced to increase the maximum wave heights which could be generated in the basin. In the original programs, the average amplitude of the flapper valve motion, which was continuously variable, was adjusted so that the largest peaks in 20 min of recording were a little less than the mechanical stops on the valve. To increase this average valve motion, an electronic clipping of the subsequent taped program was made which sliced off occasional peaks at the same voltage. This permitted adjusting the running level so that the clipped peaks caused motion just within the mechanical stops and resulted in a considerable increase in wave height with a slight cost in nonlinearity.

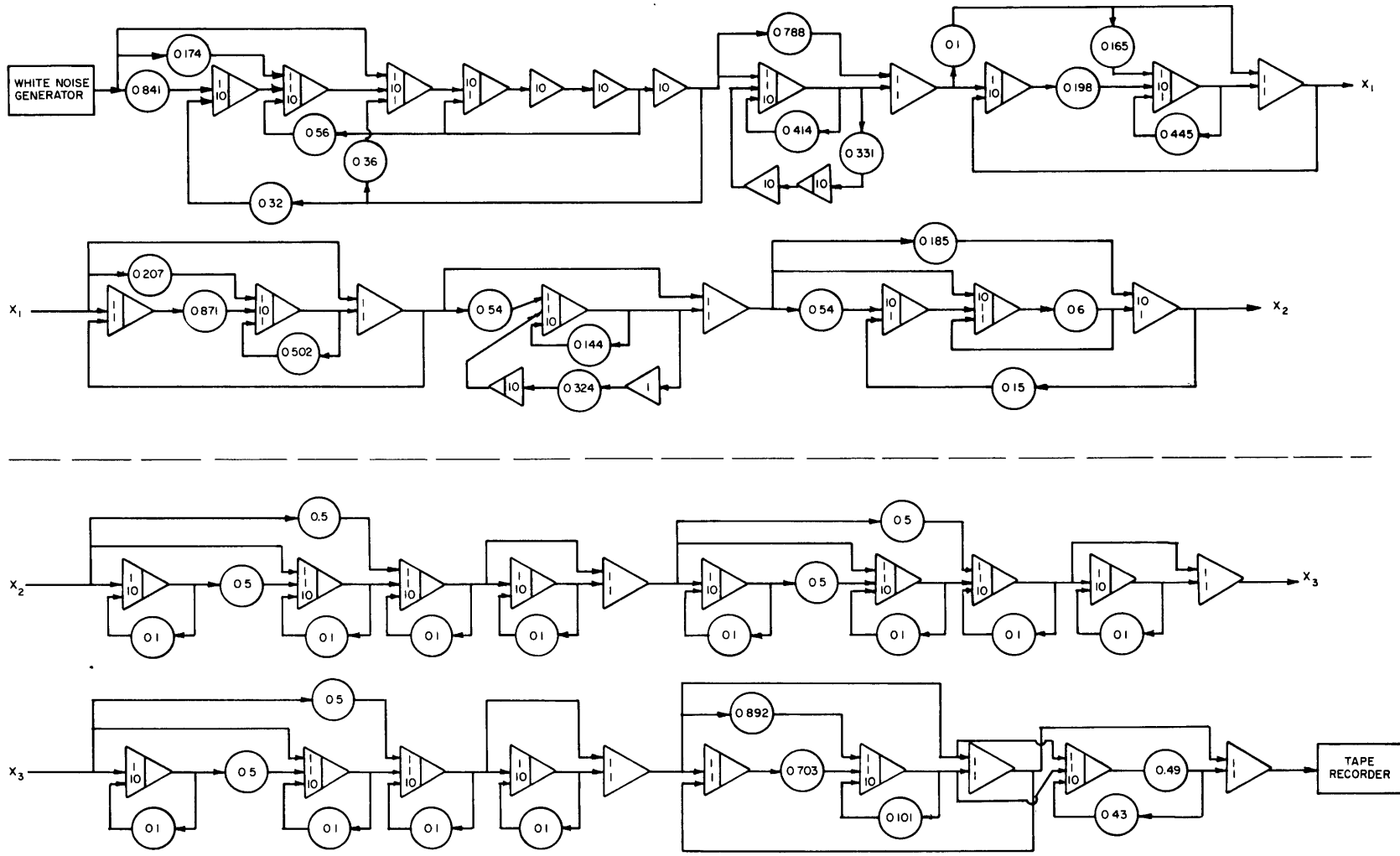

13

Figure 10 – Analog Computer Configuration Used to Insert Proper Spectral Characteristics into Wavemaker Excitation Signal

Upon spectral analysis, the white noise signal which had been used to excite the analog computer circuitry displayed a disconcerting but predictable lack of smoothness, as shown in Figure 11. This irregularity was present to some extent in every excitation and wave spectrum observed throughout this wave testing, and it greatly complicated program correction analysis.

Two sets of frequency corrections were made, using the analog computer to synthesize correction networks. The final spectra developed in this exploratory program are shown in Figures 5, 6, and 12. These corrections were not uniformly successful indicating that at least mild nonlinearities in wavemaking were present, that the analog spectral analysis equipment was deficient in performance, or that the spectra depended to some extent on where in the basin the wave heights were measured.

To investigate some of these possibilities, a series of wave measurements was made in January 1963 with variation in program running level (attenuation of the tape recorder signal), blower speed, and basin location. These resulting spectra are displayed in Figures 13, 14, and 15 where a severe variation in spectral shape occurs as a function of location, but only a mild variation develops for changes in the wave-height level. The controlling program, which was repeated during each wave measurement, was designed to have essentially constant energy content over the frequency range of interest and thus to have the shape of each spectrum proportional to the square of the frequency response of the wave-making system.

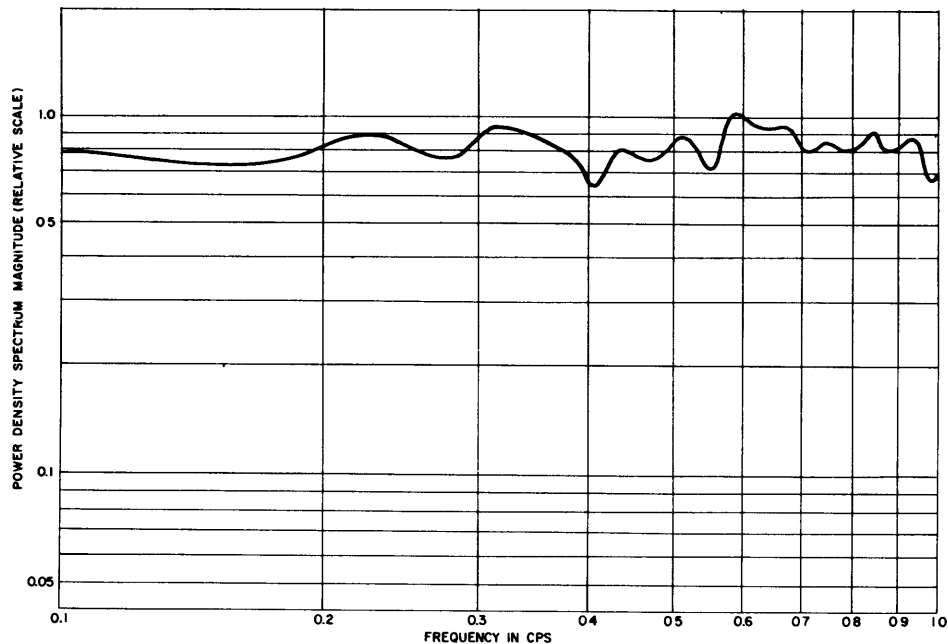

Figure 11 – Spectral Analysis of Signal from White Noise Generator with 30-Minute Recording Time

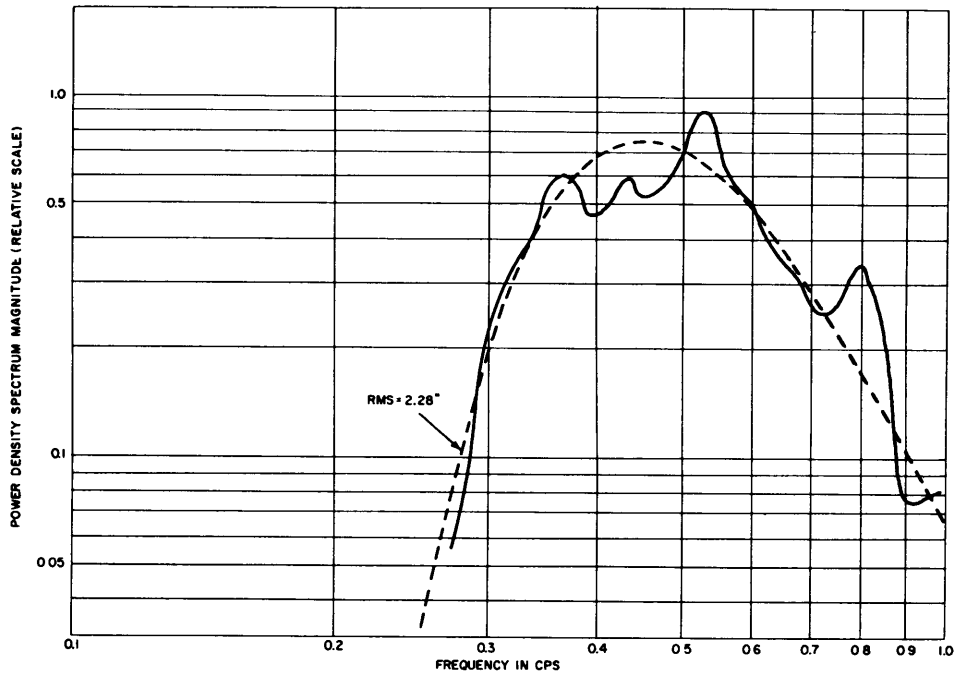

Figure 12 – Spectral Analysis of Waves Produced with Actuator Installation to Simulate Neumann Spectrum with Peak Frequency of 0.5 CPS

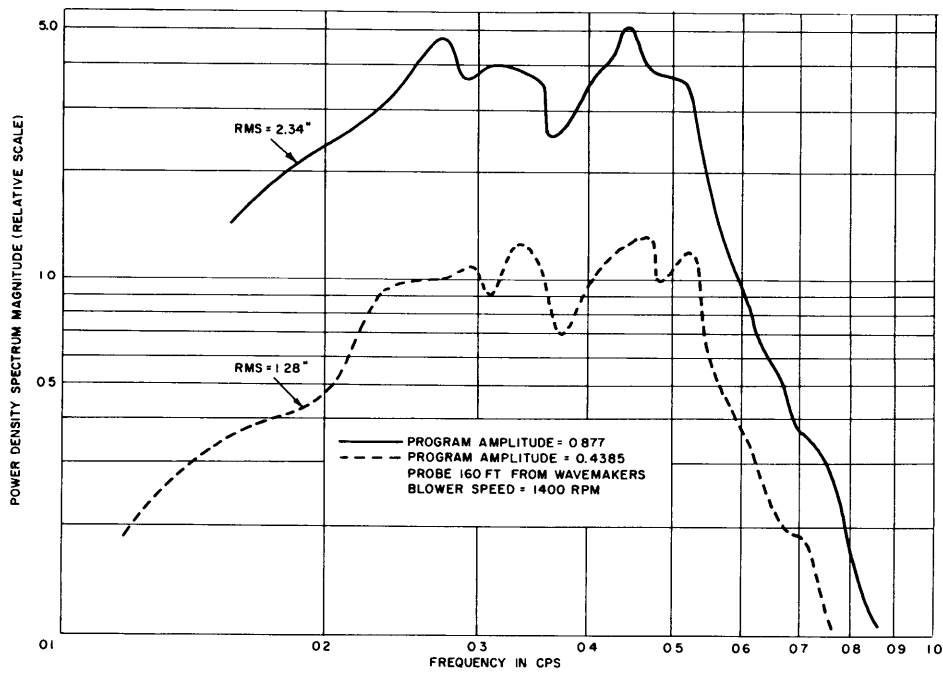

Figure 13 – Change in Wave Spectral Shape Because of 50-Percent Reduction of Excitation Level of Actuators Using Input Program with Flat Frequency Characteristics

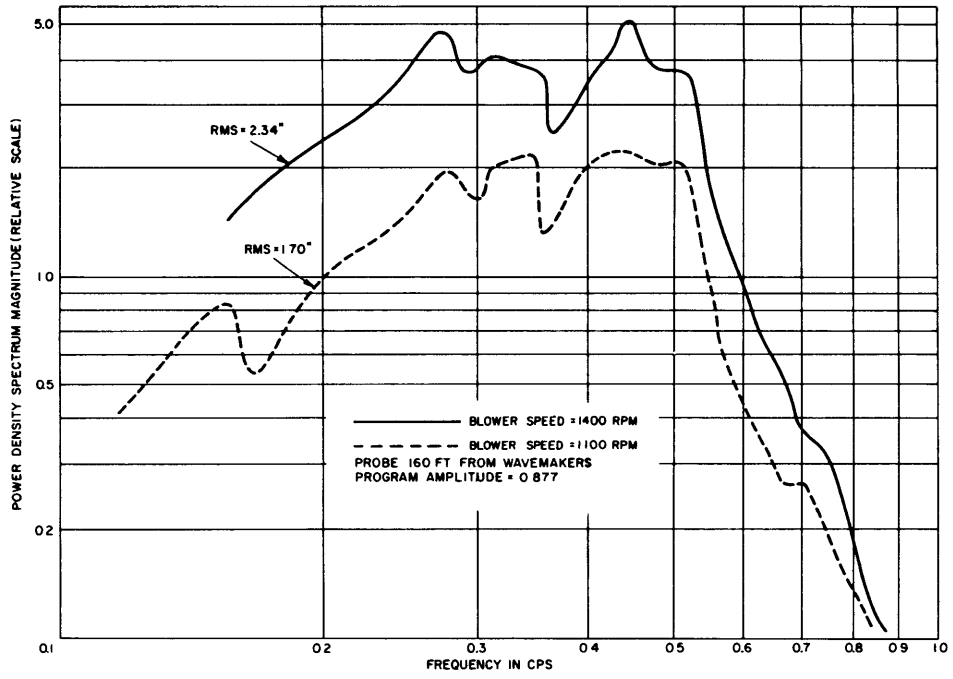

Figure 14 – Change in Wave Spectral Shape Because of 20-Percent Reduction in Air Blower Speed Using Input Program with Flat Frequency Characteristics

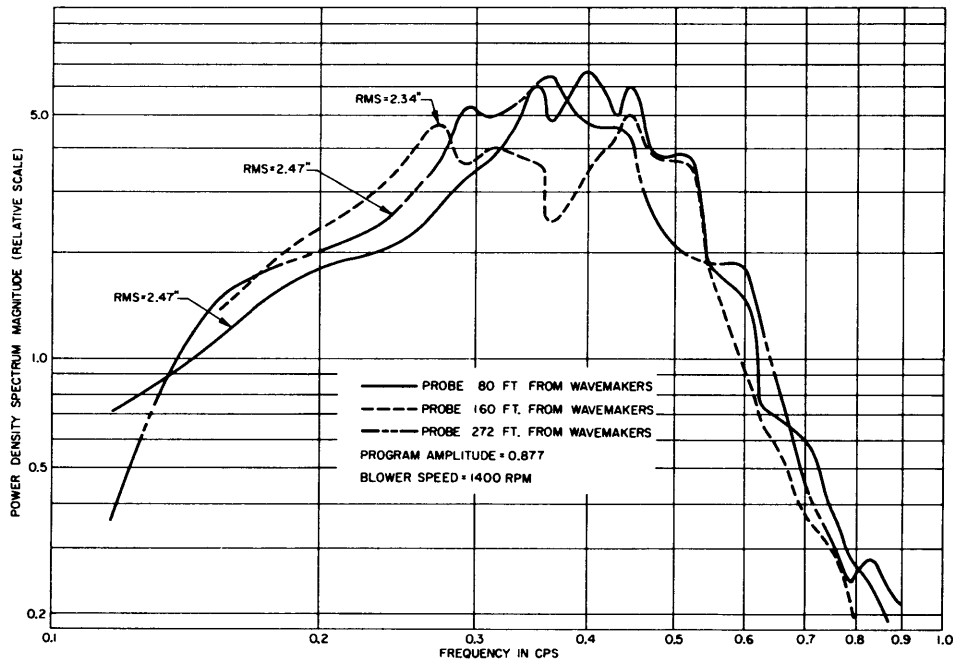

Figure 15 – Change in Wave Spectral Shape as a Function of Location in the Test Basin Using Input Program with Flat Frequency Characteristics

SUMMARY OF INFORMATION GAINED FROM SPECTRAL PROGRAMMING

The following summarizes the results obtained from this exploratory effort:

1. MASK can simulate unidirectional Gaussian sea conditions which have a specified relative distribution of wave heights and sufficient wave amplitudes to conduct model tests over a range of sea states.
2. The hydraulic actuator installation is a flexible, reliable method of producing either regular or irregular waves with carefully tailored characteristics.
3. An important initial requirement for programming using the analog computer technique is that the white noise source have a flat power density spectrum.
4. Careful attention should be paid to the reduction of unneeded high-frequency energy in programming as well as to electronic limiting.
5. Because of some nonlinear characteristics in wave generation, the initial attempt to cancel basin frequency-response characteristics should be smooth and approximate. When the initial program is adjusted to generate waves of the desired intensity, spectral analysis will yield a much better second correction, assuming linearity at least about the operating point.
6. Analog spectral analysis equipment should be used with great care since program corrections will be concerned with the difference between two relatively steep curves; this difference is very sensitive to small errors in frequency determination.
7. A significant limitation in the precision of simulation available is the spatial variation in wave-height spectra in the basin. For future programming, an average spectrum over the normal running path of the model must be defined by making very slow passes with a moving wave-height probe over this track while the random waves are being measured.

FUTURE DEVELOPMENT

With the success of the actuator installation in generating random waves with desirable properties, two research programs are underway to make use of this capability.

GENERATION OF A FAMILY OF UNIDIRECTIONAL SPECTRA

The Neumann spectrum for fully developed seas causes every average wave height to be related to some frequency of peak wave height in the power density spectrum such that when the seas become rougher, the distribution shifts lower in frequency. An engineer desiring to simulate certain sea conditions at some scale ratio λ will select a basin rms wave height which is equal to the full-scale rms wave height divided by λ and a basin peak frequency which is equal to the full-scale peak frequency multiplied by $\sqrt{\lambda}$. These relations are summarized in Figure 16, which also shows the rms wave heights achieved to date with programs described in this report. From these wave-height results, it is planned to span

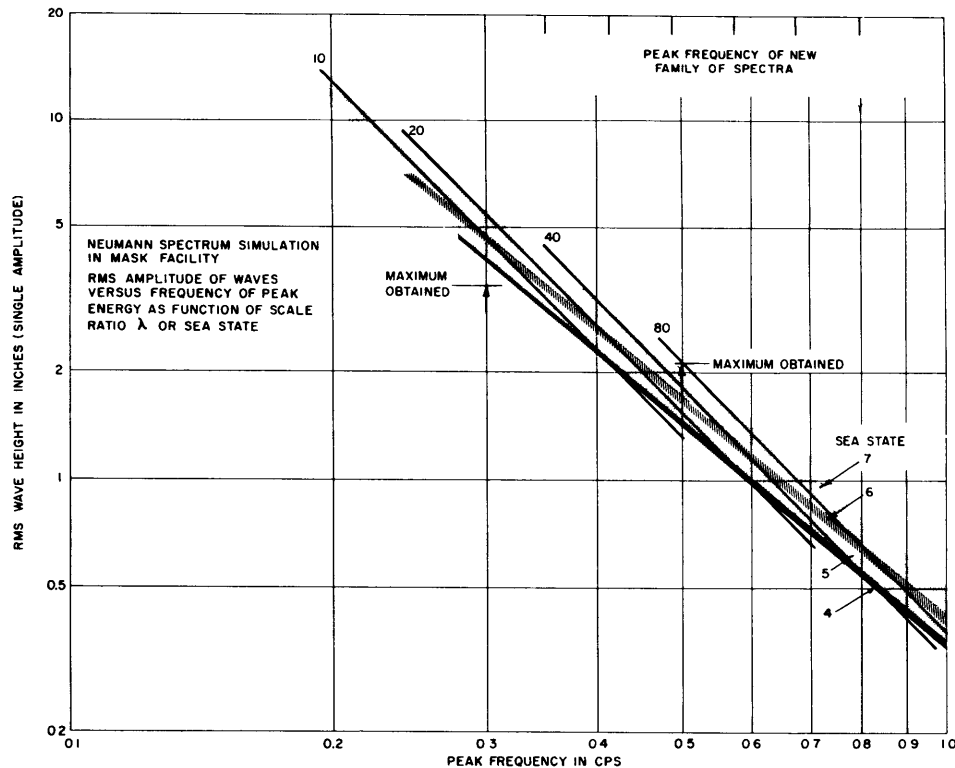

Figure 16 – Relation among Peak Frequency of Neumann Spectrum, RMS Wave Height, Model Scale Ratio λ , and Sea State for Simulated Long-Crested Seaways in the Test Basin

the useful frequency range of the basin with a set of six spectra, which will be measured so as to perform a spatial averaging. The peak frequencies of these spectra, as shown in Figure 16, are spaced so that a model of arbitrary scale ratio (within a large range) can be tested in successively higher sea states with each program. A typical model with $\lambda = 30$, for example, would be able to test in a valid Neumann spectrum in States 4 through 7 seas.

APPROACH TO THE GENERATION OF DIRECTIONAL SPECTRA

With the present installation, there are eight wavemakers which can be independently controlled from eight channels of a magnetic tape recorder. The proper programming of these units to create an adequate simulation of a directional seaway is a challenging problem. One approach is outlined here.

If a voltage sine wave of constant amplitude is used to excite each actuator but the phase lag between adjacent units is nonzero but constant, then in general a sinusoidal wave traveling at an oblique angle from the bank of wavemakers will result, apart from some second-order waves. The phase lag in degrees needed to produce a wave traveling at a fixed angle is a function of frequency. If, instead of a sinusoidal wave, it is desired to generate a program for an oblique but unidirectional random wave train, this could in theory be obtained

by passing some random voltage through a succession of seven identical linear networks, each having a constant amplitude but prescribed phase change over the frequency range (known as "all pass" networks), and then by taping each of the eight random signals.

Considering a directional spectrum to be made up of a large number of independent random wave trains, each traveling in a certain direction, an approximation to this spectrum could be made with perhaps five or seven such separate oblique wave programs produced as above and summed together on a composite tape. Assuming linearity of the wavemaking system, the desired directional properties could be well approximated both in frequency and direction through use of the techniques developed with the long-crested waves on each of the oblique components. Needless to say, such an ambitious program must rest on a foundation of experience with random unidirectional waves generated with the actuator installation.

ACKNOWLEDGMENTS

The author is grateful to Mr. Joseph E. Russ for his able assistance in all phases of the wavemaking tests and to the staff of the Motions Analysis Section for technical advice in the use of analog computing equipment.

REFERENCES

1. Brownell, W.F., "Two New Hydromechanics Research Facilities at the David Taylor Model Basin," Paper presented before Chesapeake Section, Society of Naval Architects and Marine Engineers (Dec 1962). Also David Taylor Model Basin Report 1690 (Dec 1962).
2. Vossers, G., "Fundamentals of the Behavior of Ships in Waves," International Shipbuilding Progress, Vol. 6, No. 63 (Nov 1959).

INITIAL DISTRIBUTION

Copies

9 CHBUSHIPS
 3 Tech Lib (Code 210L)
 1 Appl Res (Code 340)
 1 Lab Mgt (Code 320)
 1 Prelim Design Br (Code 420)
 3 ASW Support Br (Code 373A)
 Attn: Mr. B.K. Couper

2 CHBUWEPS
 2 Aero and Hydro Br (Code RAAD-3)

4 CHONR
 1 Naval Applications (Code 406)
 1 Math Br (Code 432)
 1 Fluid Dynamics (Code 438)
 1 Undersea Programs (Code 466)

1 ONR, New York

1 ONR Pasadena

1 ONR, Chicago

1 ONR, Boston

1 ONR, London

1 NAVSHIPYD NORVA

1 NAVSHIPYD BSN

1 NAVSHIPYD PTSMH

1 NAVSHIPYD PUG

1 COMSURASDEVDET

1 CDR, USNOL, White Oak

1 DIR, USNRL

1 CDR, USNOTS, China Lake

1 CDR, USNOTS, Pasadena

1 CO & DIR, USNMDL

1 CO, USNUOS

1 SUPSHIP, Quincy

2 SUPSHIP, Camden
 1 Mr. J.W. Thompson, Nav. Arch (Design)

1 DIR, Langley RESCENHYDRODIV

1 CDR, USN Missile Ctr, Point Mugu

Copies

1 CO, Frankford Arsenal Off Air Res

1 DIR, NATBUSTAND

1 BUWEPSREP, Eclipse Pioneer Div,
 Bendix Aviation Corp, Teterboro

1 DIR, DEF R & E

20 CDR, DDC , Attn: TIPDR

2 ADMIN, MARAD
 1 Mr. Vito L. Russo,

3 NNSB & DD Co, Newport News
 1 Asst Nav Arch
 2 Dir, Hydrau Lab

1 Dir, Hydrau Lab, Univ of Colorado, Boulder

1 Dir, Hydrau Res Lab, Univ of Connecticut,
 Storrs

1 Dir, Scripps Inst of Oceanography, Univ of
 California, La Jolla

1 Dir, Fluid Mech Lab, New York Univ, New York

1 Dir, Robinson Hydrau Lab, Ohio St Univ,
 Columbus

1 Dir, Hydrau Lab, Penn St Univ, University Park

1 Dir, ORL, Penn St Univ, University Park

2 Dir, Woods Hole Oceanographic Inst,
 1 Dr. Columbus O'D. Iselin

1 Dir, Hydrau Lab, Univ of Wisconsin, Madison

1 Dir, Hydrau Lab, Univ of Washington, Seattle

1 Admin, Webb Inst of Nav Arch, Glen Cove

2 Dir Iowa Inst of Hydrau Res, St Univer of Iowa,
 Iowa City
 1 Dr. L. Landweber

1 Dir St. Anthony Falls Hydrau Lab, Univ of
 Minnesota, Minneapolis

1 Dir of Res, Tech Inst, Northwestern Univ,
 Evanston

Copies

- 4 Head, Dept NAME, MIT Cambridge
 - 1 Prof. M.A. Abkowitz
 - 1 Prof. F.M. Lewis
 - 1 for fwdg to Dr. George Manning
- 1 James Forrestal Res Ctr, Lib, Princeton Univ,
Attn: Mr. M.H. Smith, Asst to Dir
- 1 Tech Dir, Ship Struc Com, NRC
- 1 Dr. M.L. Albertson, Head, Fluid Mech Res,
Dept of Civil Engin, Colorado St Univ,
Fort Collins
- 1 Mr. Osvald J. Sibul, Dept of Engin, Univ of
California, Berkeley
- 1 Dr. Willard J. Pierson, Jr., Prof of Meteorology
and Oceanography, Col of Engin, New York
Univ, New York
- 1 Dr. V.G. Szebehely, Genl Elec Co., Aero Sci
Lab, Philadelphia
- 1 Dir, Alden Hydrau Lab, Worcester Polytech
Inst, Worcester
- 1 Dir, APL, Johns Hopkins Univ, Silver Spring
- 1 Dir, Fluid Mech Lab, Columbia Univ, New York
- 1 Dir, Fluid Mech Lab, Univ of California,
Berkeley
- 1 Dir, Davidson Lab, SIT Hoboken
- 1 Dir, Exptl Nav Tank, Univ of Michigan,
Ann Arbor
- 1 Dir, Inst for Fluid Dyn and Appl Math, Univ
of Maryland, College Park

MIT LIBRARIES

DUPL



3 9080 02754 4615

