

5
0
4

1

V393
.R46

MIT LIBRARIES



3 9080 02754 0258

THE DAVID W. TAYLOR MODEL BASIN

UNITED STATES NAVY

THE EFFECT OF RIGID GUIDE VANES ON THE VIBRATION
AND DRAG OF A TOWED CIRCULAR CYLINDER

BY G. GRIMMINGER

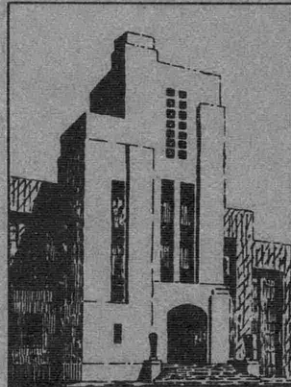
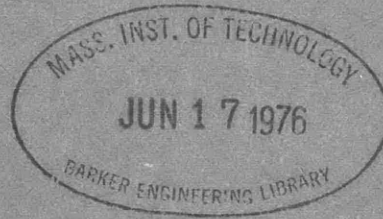

RESTRICTED

APRIL 1945

DECLASSIFIED
PER 1187

REPORT 504

NAVY DEPARTMENT
DAVID TAYLOR MODEL BASIN
WASHINGTON, D. C.

RESTRICTED

The contents of this report are not to be divulged or referred to in any publication. In the event information derived from this report is passed on to officer or civilian personnel, the source should not be revealed.

RESTRICTED

REPORT 504

THE EFFECT OF RIGID GUIDE VANES ON THE VIBRATION
AND DRAG OF A TOWED CIRCULAR CYLINDER

BY G. GRIMMINGER

APRIL 1945

DAVID TAYLOR MODEL BASIN

Rear Admiral H.S. Howard, USN
DIRECTOR

Captain H.E. Saunders, USN
TECHNICAL DIRECTOR

HYDROMECHANICS

Comdr. E.A. Wright, USN
K.E. Schoenherr, Dr.Eng.
HEAD NAVAL ARCHITECT

AEROMECHANICS

Lt. Comdr. C.J. Wenzinger, USNR

STRUCTURAL MECHANICS

Comdr. J. Ormondroyd, USNR
D.F. Windenburg, Ph.D.
HEAD PHYSICIST

REPORTS, RECORDS, AND TRANSLATIONS

Lt. M.L. Dager, USNR

M.C. Roemer
TECHNICAL EDITOR

PERSONNEL

The experiments were conducted and the report was written by G. Grimminger of the Hydrodynamics Section of the David Taylor Model Basin staff under the direction of Comdr. E.A. Wright, USN, and Mr. L. Landweber.

THE EFFECT OF RIGID GUIDE VANES ON THE VIBRATION AND DRAG
OF A TOWED CIRCULAR CYLINDER

ABSTRACT

When an elastically supported cylinder is towed normal to its axis through a fluid, a lateral vibration of the cylinder is excited by the periodic shedding of eddies in the stream. The experiments described in this report show that this vibration can be reduced or eliminated by attaching a pair of rigid guide vanes, one on each side and extending the length of the cylinder.

The shape of the vanes does not seem important in eliminating vibration; in fact a simple flat plate fin extending along each side of the cylinder is sufficient for this purpose.

However, the drag of the system of cylinder plus guide vanes varies greatly with the shape of the vanes, and is found to depend mainly upon 1) the distance between the trailing edges of the vanes and 2) the angular position of the leading edges of the vanes relative to the axis of the cylinder. With one pair of rigid guide vanes tested, it was possible to reduce the drag of the system to one-half that of the plain cylinder without guide vanes.

The experiments revealed that the drag of a vibrating cylinder is considerably greater than that of a non-vibrating cylinder in the speed range where the amplitude of vibration is a maximum. A simple analysis is given to explain this phenomenon.

INTRODUCTION

When a circular cylinder moves through a fluid in a direction approximately normal to its axis, eddies are shed periodically from the cylinder, forming a flow pattern known as the Kármán vortex street. Each time an eddy is released, an unbalanced lateral force acts on the cylinder and, if the cylinder is free to vibrate in a direction perpendicular to its motion, the unbalanced forces produce a periodic lateral vibration of the cylinder. If the cylinder is rigidly clamped at one end and if the frequency at which the eddies are shed is approximately equal to the natural frequency of the clamped cylinder, resonance occurs and the amplitude of vibration of the cylinder may become quite large.

In an attempt to eliminate this vibration by modifying the vortex pattern behind the cylinder, experiments have been carried out at the David Taylor Model Basin to investigate the effect of rigid guide vanes arranged parallel to the axis of the cylinder. Since guide vanes influence the flow pattern and affect the drag as well as the vibration, measurements were made

of the drag of a cylinder when towed alone and when fitted with guide vanes of various designs and arrangements.

TEST APPARATUS AND PROCEDURE

The experiments were carried out in the deep water basin of the Taylor Model Basin, with solid brass cylinders having an outside diameter of $15/16$ inch. The cylinders were supported from the dynamometer of the towing carriage by the bracket ordinarily used for towing small models. The

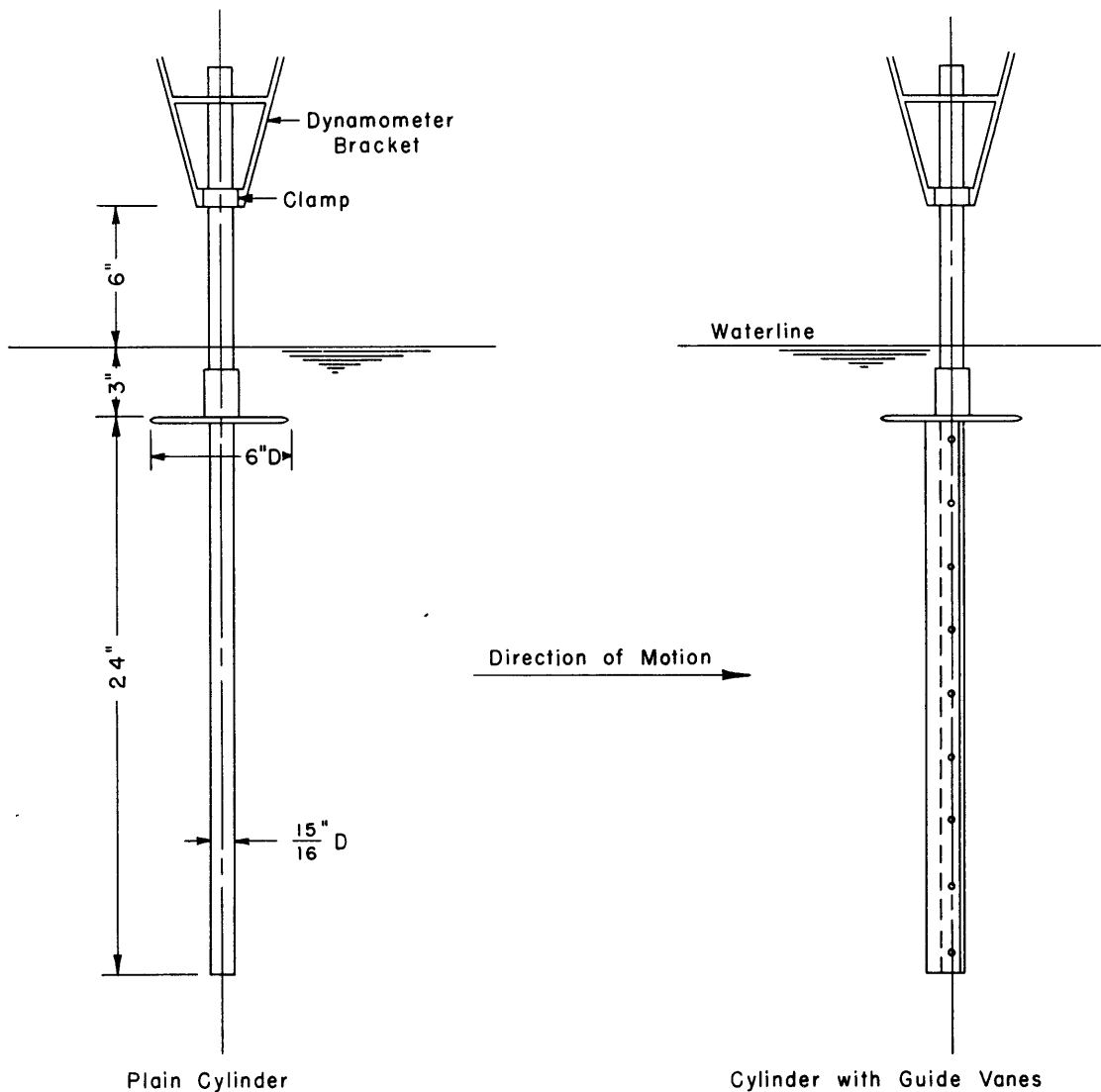

Figure 1 - Arrangement for Towing Cylinders by the Floating Beam of the Carriage over the Deep Water Basin to Measure the Resistance with Various Designs of Guide Vanes

cylinders were rigidly clamped in the towing bracket and extended 33 inches below the bottom of the clamp, with 27 inches under the still water level; see Figure 1. To reduce surface effects as far as possible a thin brass disk 6 inches in diameter was secured to each cylinder 3 inches below the water surface.

One of the cylinders used in these tests was plain and the other had a series of tapped holes along both sides for fastening various guide vanes. The guide vanes were 24 inches long, extending from the surface plate to the lower end of the cylinder. The drag was measured at different speeds up to 10 knots.

Supplementary drag measurements were made with the surface plate attached to the immersed end of a short cylinder extending only 3 inches under water, to determine the drag of the surface plate and that portion of the cylinder above it. This drag was subtracted from the measurements on the other cylinders so that, except for possible interference effects, the results refer to the 24-inch length of immersed cylinder below the surface plate.

Drag measurements were made with 4 different pairs of guide vanes made of sheet copper $1/64$ inch thick and fastened to each side of the cylinder by machine screws, as shown in Figure 2. In all cases each guide vane was separated from the side of the cylinder by a washer $1/10$ inch thick. The width of the opening at the rear could be varied by a machine screw and nut assembly.

Measurements of drag were made with Guide Vanes 1, 2, and 3 at different speeds and with various amounts of opening at the rear. No variation was made in the rear opening of Guide Vane 4.

Guide Vanes 2, which were shorter from the leading to the trailing edge than Guide Vanes 1 and therefore more compact, were tested to find whether short vanes were as effective in eliminating cylinder vibration as larger ones.

Guide Vanes 3 were the same as Guide Vanes 2 in all respects except that the leading edge of Guide Vanes 3 began opposite the 45-degree position on the cylinder instead of near the 90-degree point. This design was tested only with a 0.9-inch opening at the rear.

To carry to an extreme the enlargement of the opening of the guide vanes at the rear, Guide Vanes 4, consisting simply of flat plates extending down each side of the cylinder, were tested.

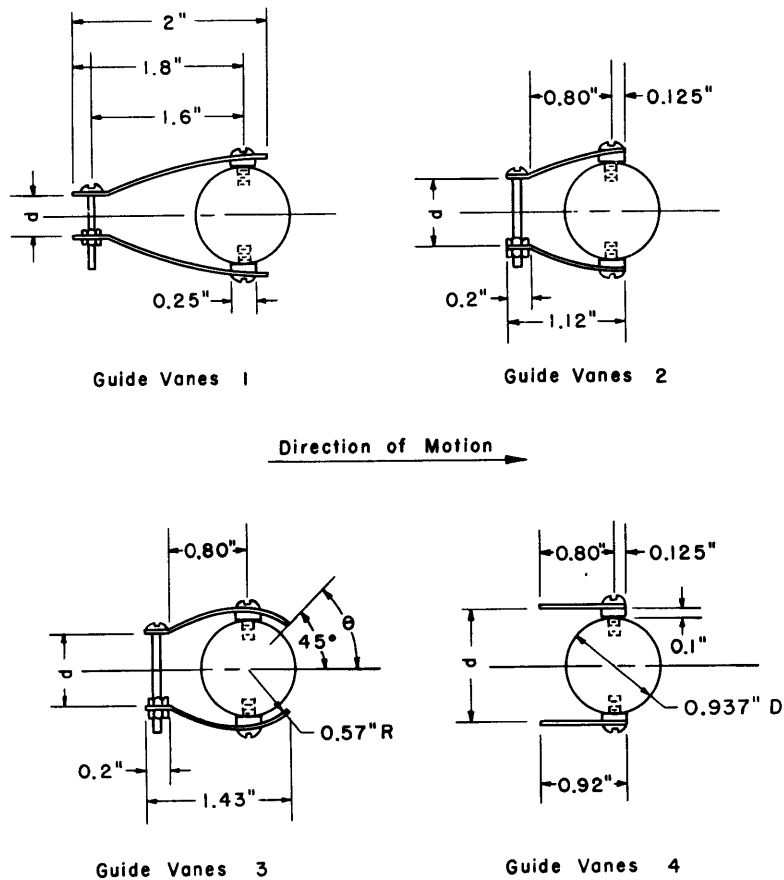

Figure 2 - Rigid Guide Vanes for the Circular Cylinder

TEST RESULTS

The data for the cylinder fitted with Guide Vanes 1 are plotted in Figure 3 to show the variation of drag with speed for different amounts of opening between the guide vanes at the trailing edge. The curve for the plain cylinder without guide vanes is included for comparison. The curve of resistance for the plain cylinder has a pronounced hump at 4.25 knots, which corresponds to resonance vibration, since the amplitude of vibration was observed to be a maximum at this speed. This result shows that, in the speed range corresponding to marked lateral vibration, a vibrating cylinder has greater drag than one which is not vibrating.

The curves of Figure 3 show that the drag becomes less as the width of the opening at the rear of the guide vanes is increased. The observations showed that this width can be almost as much as the diameter of the cylinder itself and the guide vanes will still prevent vibration of the cylinder. When

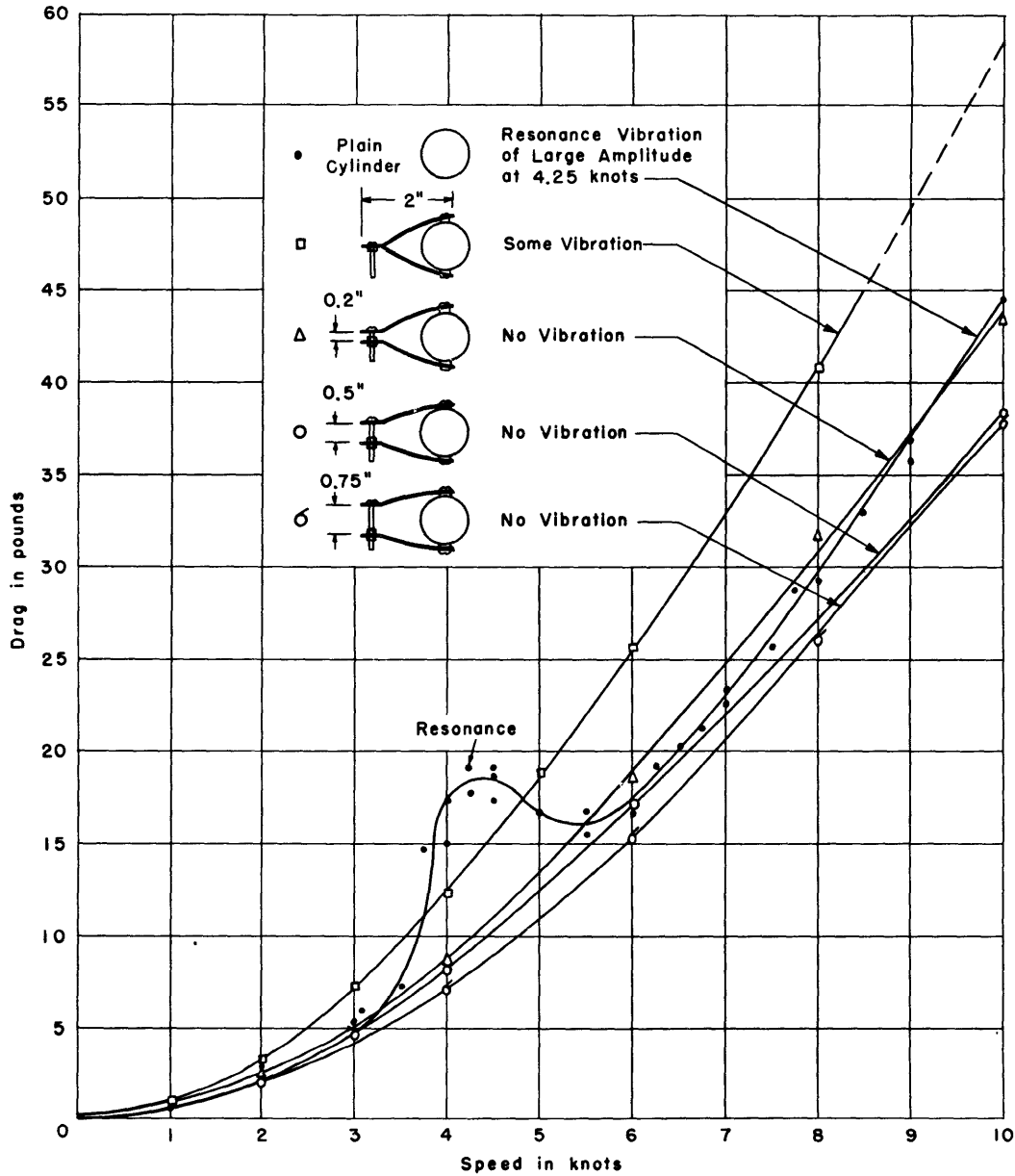

Figure 3 - Drag of Cylinder with Guide Vanes 1 with Various Openings at the Rear

the opening at the rear of Guide Vanes 1 was 0.75 inch, the largest opening tested on these vanes, the total drag of the combination was less than for the plain cylinder alone. With small openings at the rear, the drag was greater than for the plain cylinder. Except when the guide vanes were closed at the trailing edges, the vibration of the cylinder was largely eliminated.

The results of drag measurements with Guide Vanes 2, short guide vanes, are given by Curve C, Figure 4. As for the longer vanes, the least

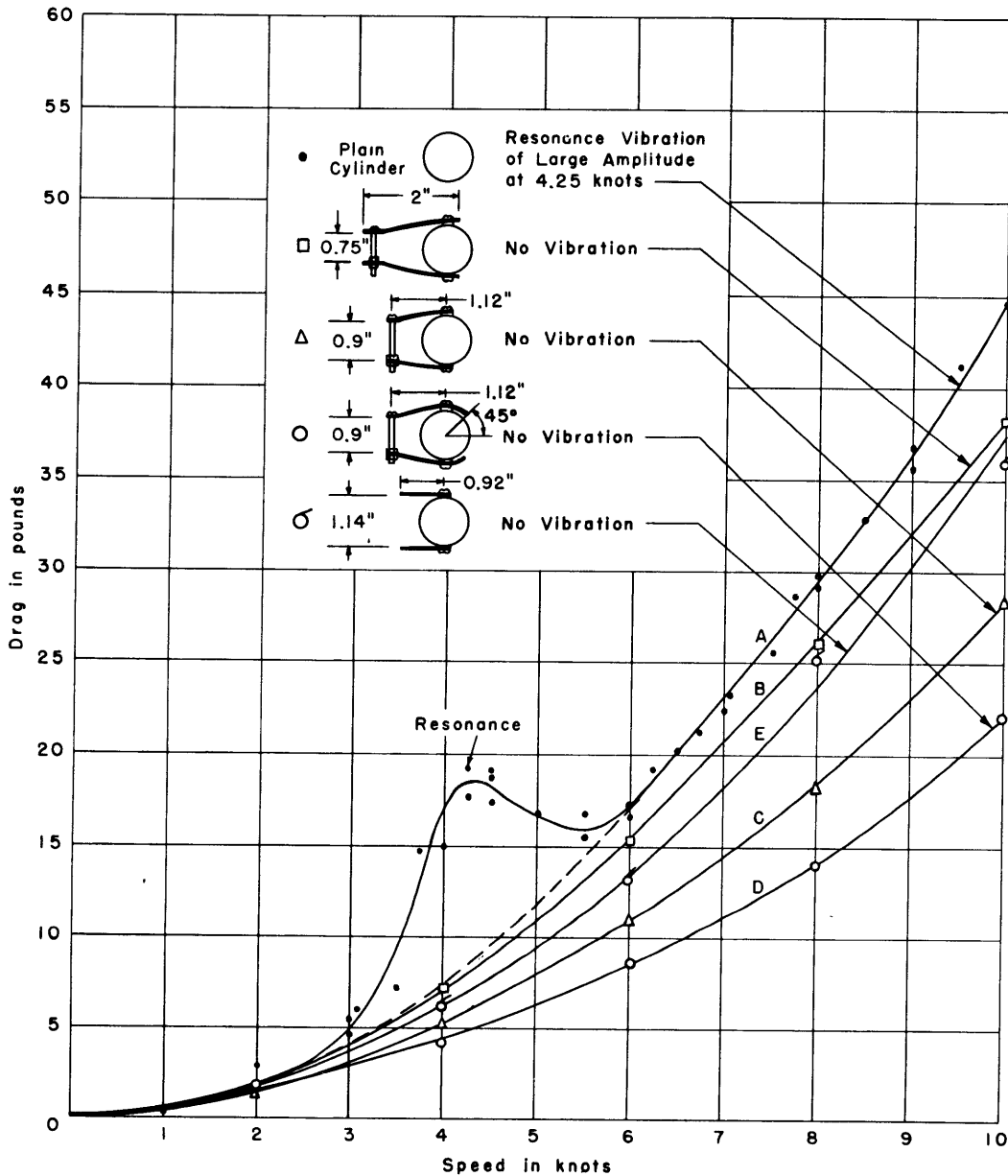

Figure 4 - Drag of Circular Cylinder with Various Guide Vanes

drag occurred when the opening at the rear was largest. With an opening at the rear of 0.9 inch, practically equal to the diameter of the cylinder which was 0.937 inch, no vibration was observed. The total drag of the combination was considerably less than for a plain cylinder.

The results of measurements with Guide Vanes 3, extending 45 degrees forward of the transverse plane through the axis, are given by Curve D, Figure 4. The total drag is less than for any of the other designs and about

one-half as large as the drag of the plain cylinder which is shown by Curve A. Again the vibration of the cylinder was eliminated.

The drag of the cylinder with Guide Vanes 4, the flat, short vanes, is given by Curve E in Figure 4. No vibration of the cylinder was observed in tests with this type of guide vane. It is seen that even as simple a set of guide vanes as two flat plates is sufficient not only to decrease the drag of a cylinder, despite the added resistance of the plates, screws, and washers, but also to eliminate the vibration.

In Curve A of Figure 4 for the plain cylinder, a broken line has been drawn through the speed range in which the resonance peak occurs, to show the variation of drag with speed for a plain cylinder without vibration. This broken portion of the curve fairs into the experimental values at the low- and the high-speed ends where the vibration amplitude is small and has little effect on drag. Thus, in the present case, the effect of the resonance vibration at 4.25 knots, where the lateral vibration of the lower end of the cylinder was of the order of 4 to 5 inches, is to increase the drag from 8.5 pounds to 18.5 pounds, which is more than twice the drag when there is no vibration. An explanation of this effect in terms of the Kármán street is given in the Appendix.

CONCLUSIONS

When a circular cylinder is towed through a fluid in a direction normal to its axis, the lateral vibration excited by the eddy formation can be eliminated by attaching a suitable pair of rigid guide vanes extending over the length of the cylinder.

The drag of the system consisting of the cylinder plus guide vanes depends mainly upon the opening between the trailing edges of the guide vanes and upon the position of the leading edges of the vanes relative to the axis of the cylinder.

It has been shown that the drag of the system, cylinder plus guide vanes, can be made considerably less than the drag of the cylinder alone, provided the distance between the trailing edges of the vanes is large and provided the leading edges start well forward of the 90-degree point around the cylinder.

These conclusions apply only to rigid guide vanes with a fixed position relative to the cylinder and to the direction of flow.

APPENDIX

A SIMPLE ANALYSIS OF THE DRAG OF A VIBRATING CYLINDER

An explanation is proposed here for the considerable increase which occurs in the drag of a cylinder when it vibrates. The analysis is similar to that in Appendix 1, Example 2, of Reference (1).*

When a body such as a cylinder moves through a fluid, alternate vortices are periodically shed from the cylinder, forming a vortex trail, as shown in Figure 5a, for a non-vibrating cylinder. Von Kármán has shown (2) that the drag of a cylinder, or of any body, can be calculated from the geometrical pattern of the eddies in its wake from the equation

$$D = \frac{\rho}{2} dU^2 \left[1.587 \frac{u}{U} - 0.628 \left(\frac{u}{U} \right)^2 \right] \frac{l}{d} \quad [1]$$

where D is the drag per unit length of the body,

u is the velocity of the vortex system,

U is the velocity of the cylinder,

l is the distance between successive vortices in the same row,

d is the diameter of the cylinder, and

ρ is the mass density of the fluid.

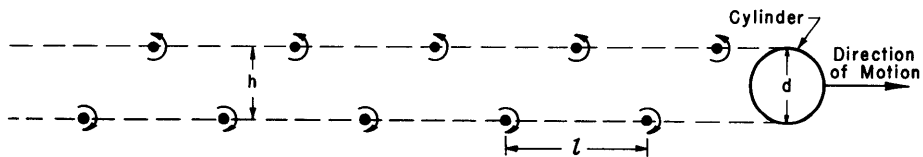

Figure 5a - Non-Vibrating Cylinder

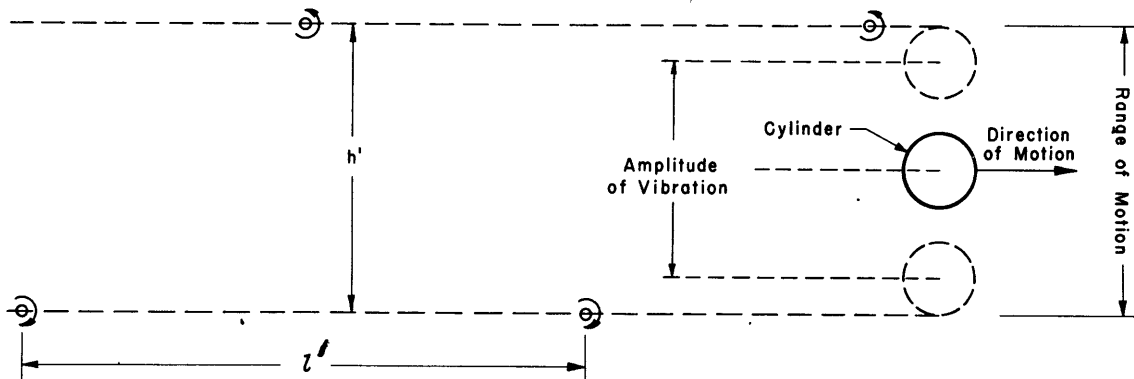

Figure 5b - Vibrating Cylinder

Figure 5 - Schematic Diagram of Vortex Trails behind a Circular Cylinder

* Numbers in parentheses indicate references on page 10 of this report.

It has been shown, furthermore, that the necessary condition for stability of the vortex trail is that $l = 3.56 h$, where h is the width of the vortex street, that is, the distance between the two rows of vortices. With this condition, Equation [1] becomes

$$D = \frac{\rho}{2} d U^2 \left[1.587 \frac{u}{U} - 0.628 \left(\frac{u}{U} \right)^2 \right] \frac{3.56 h}{d} \quad [2]$$

For a non-vibrating cylinder and for a Reynolds number Ud/ν less than 2×10^5 , the distance h between the vortex rows is approximately equal to the diameter of the cylinder.

Such asymmetrical vortex development behind the cylinder gives rise to a side thrust that continually reverses its direction. If the cylinder is not rigidly supported, it will oscillate from one side to the other, and this oscillation will be especially large and violent if the natural frequency of vibration of the cylinder is in resonance with the frequency of the vortex formation.

If the cylinder is allowed to vibrate, as it does when it is clamped at one end, the geometry of the vortex street must necessarily change. The most obvious change that one might expect is an increase in the distance h between the vortex rows, as shown in Figure 5b. The equation for the drag of the cylinder in this case will be

$$D' = \frac{\rho}{2} d U^2 \left[1.587 \frac{u}{U} - 0.628 \left(\frac{u}{U} \right)^2 \right] \frac{3.56 h'}{d} \quad [3]$$

where h' is the distance between the vortex rows, and D' is the drag when the cylinder is vibrating.

By dividing Equation [3] by Equation [2], one obtains $D'/D = h'/h$ and, since h is approximately equal to d , it follows that

$$D' = \frac{h' D}{d} \quad [4]$$

In the experiments described in this report, it was observed that the amplitude* of oscillation of the lower or immersed end of the cylinder at resonance was roughly about 3 or 4 inches. Hence h' was about 4 or 5 inches. Since the upper end of the cylinder was rigidly clamped, the average value of h' for the cylinder was about 2 inches. Thus, using the approximate value of 2 inches for h' and 1 inch for d , one obtains

$$D' \approx 2D \quad [5]$$

* The amplitude of oscillation is the total lateral motion of the center of the cylinder.

From Curve A, Figure 4, it will be seen that the drag of the vibrating cylinder at resonance is about twice as large as the drag when there is no vibration, which is in agreement with the result found in Equation [5].

It is concluded that, when a cylinder vibrates, its drag increases and the increase is equal to the drag of a larger non-vibrating cylinder having a diameter equal to the range of lateral motion of the vibrating cylinder, as shown in the diagram of Figure 5b.

REFERENCES

(1) "Flow about a Pair of Adjacent, Parallel Cylinders Normal to a Stream - Theoretical Analysis," by L. Landweber, TMB Report 485, July 1942.

(2) "Applied Hydro- and Aeromechanics," Prandtl-Tietjens, McGraw-Hill Book Company, New York, 1934, pp. 132-135.

Additional data on this project can be found on TMB File SS/S24-9 and under BuShips Research Symbol C168.

MIT LIBRARIES

DUPL



3 9080 02754 0258

