

6
3
9

V393
.R46

0676

#1

MIT LIBRARIES



3 9080 02754 0498

THE DAVID W. TAYLOR MODEL BASIN

UNITED STATES NAVY

CONSTRUCTION AND OPERATION OF THE LOSENHAUSEN 440-POUND VIBRATION GENERATOR

BY E. O. BERDAHL, C Sp(X)(AA) USNR

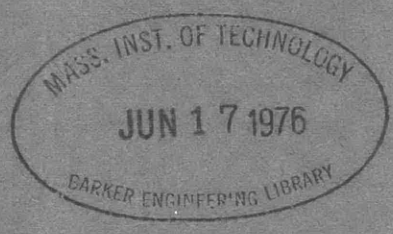
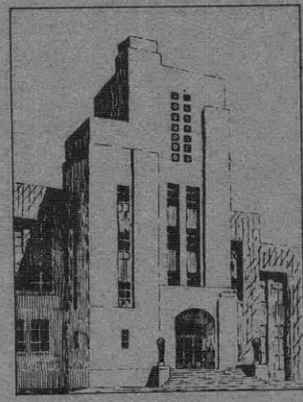

RESTRICTED

APRIL 1945

REPORT 539

NAVY DEPARTMENT
DAVID TAYLOR MODEL BASIN
WASHINGTON, D. C.

RESTRICTED

The contents of this report are not to be divulged or referred to in any publication. In the event information derived from this report is passed on to officer or civilian personnel, the source should not be revealed.

RESTRICTED

REPORT 539

CONSTRUCTION AND OPERATION OF THE LOSENHAUSEN
440-POUND VIBRATION GENERATOR

BY E. O. BERDAHL, C Sp(X)(AA) USNR

APRIL 1945

DAVID TAYLOR MODEL BASIN

Rear Admiral H.S. Howard, USN
DIRECTOR

Captain H.E. Saunders, USN
TECHNICAL DIRECTOR

HYDROMECHANICS

Comdr. E.A. Wright, USN

K.E. Schoenherr, Dr.Eng.
HEAD NAVAL ARCHITECT

AEROMECHANICS

Lt. Comdr. C.J. Wenzinger, USNR

STRUCTURAL MECHANICS

Comdr. J. Ormondroyd, USNR

D.F. Windenburg, Ph.D.
HEAD PHYSICIST

REPORTS, RECORDS, AND TRANSLATIONS

Lt. M.L. Dager, USNR

M.C. Roemer
TECHNICAL EDITOR

PERSONNEL

This report is the work of E.O. Berdahl, C Sp(X)(AA) USNR. All numerical data were checked by R.B. Allnutt, Sp(X)1/c USNR.

CONSTRUCTION AND OPERATION OF THE LOSENHAUSEN
440-POUND* VIBRATION GENERATOR

ABSTRACT

A small Losenhausen vibration generator is described which is capable of developing sinusoidal forces and moments in several directions. It is a self-contained d-c motor-driven device convenient for exciting the natural frequency of vibration in various objects such as ship structures, decks, girders, trusses, and foundations of relatively small size, for a study of their dynamic characteristics. The design and operation of the machine are discussed in detail.

The generator with its controls weighs about 315 pounds when boxed for shipment; the generator and the various accessories can easily be supported and handled without difficulty. The vibration generator alone weighs only 140 pounds and is capable of exerting alternating forces up to 440 pounds single amplitude at speeds from 850 RPM to 3910 RPM. It can develop moments, both tilting and torsional, up to 230 pound-feet at the same speeds. The practical speed range is from 300 RPM to 3000 RPM.

INTRODUCTION

In the late 1920's, German scientists and engineers began an investigation of the elastic properties of structures by determining their vibration characteristics. Their method consisted (1) (2)** in using a series of unbalanced rotating weights, driven by a motor, to set the structure in resonant vibration, and then comparing the stiffness thus found with a calculated value. If the structure was found to be more limber than was estimated, as evidenced by a lower natural frequency, it was assumed that the joints were not sufficiently rigid, or that there was a defect somewhere in the construction.

When this scheme was brought to the attention of the then Bureau of Construction and Repair of the Navy Department and of the U. S. Experimental Model Basin in 1929, the possibilities of investigating the elastic characteristics of ship structures and of models representing them looked attractive, so much so that arrangements were made to purchase from the Losenhausen Werke, in Düsseldorf, Germany, two vibration generators. The

* Vibration generators are generally rated in terms of the maximum peak force they are designed to produce under continuous operation.

** Numbers in parentheses indicate references on page 20 of this report.

larger machine, described elsewhere (3), can produce a maximum rated exciting force of 44,000 pounds, and the small machine a maximum force of 440 pounds.

The small generator has been used extensively (4) (5) (6) since it was delivered in 1931. Several years ago the cables, plugs, sockets, and fuses were replaced with products of American manufacture. Recently it was found necessary to renew the train of gears and the idler-gear bearings.

The large machine has been employed on several occasions (7). It will excite large structures in comparatively low natural frequencies, 54 RPM to 480 RPM.

Although the exciting force of the small machine is quite moderate, it has a large speed range from 300 RPM to 3910 RPM.

To supplement the two machines purchased in 1931, the David Taylor Model Basin designed and built a third vibration generator (8) which can develop sinusoidal exciting forces up to 5000 pounds continuously and 20,000 pounds for brief periods at speeds from 360 RPM to 1500 RPM. It can develop moments, both tilting and torsional, up to 9400 pound-feet continuously and 37,600 pound-feet for short periods at the same speeds.

The general scheme of construction of the small Losenhausen vibration generator is shown in Figure 1. It consists of two parallel shafts geared together by a train of four helical gears so as to rotate in opposite directions at the same speed. Each shaft carries the armature of a d-c shunt motor and has on each end a disk carrying a pair of weights capable of being clamped at various relative positions about the circumference of the disk. By shifting the weights properly, as shown subsequently, vertical sinusoidal forces as well as torsional or tilting sinusoidal moments may be obtained. The magnitude of the maximum forces or moments developed is proportional to the square of the speed and directly proportional to the amount of unbalance.

PRINCIPLES OF OPERATION

With a vibration generator of the type shown in Figure 1, it is possible by proper mounting and adjustment to produce linear vibration in either the vertical or the horizontal direction, and to produce periodic tilting or torsional moments. The frame of the machine is built in the form of a rectangular box, suitable for mounting on any one of three of its faces.

The relative positions of the movable weights when set to produce vertical forces normal to the plane through the shaft axes are shown in the top row of views in Figure 2. To obtain horizontal excitation the generator is mounted with the plane through the shaft axes in a vertical direction.

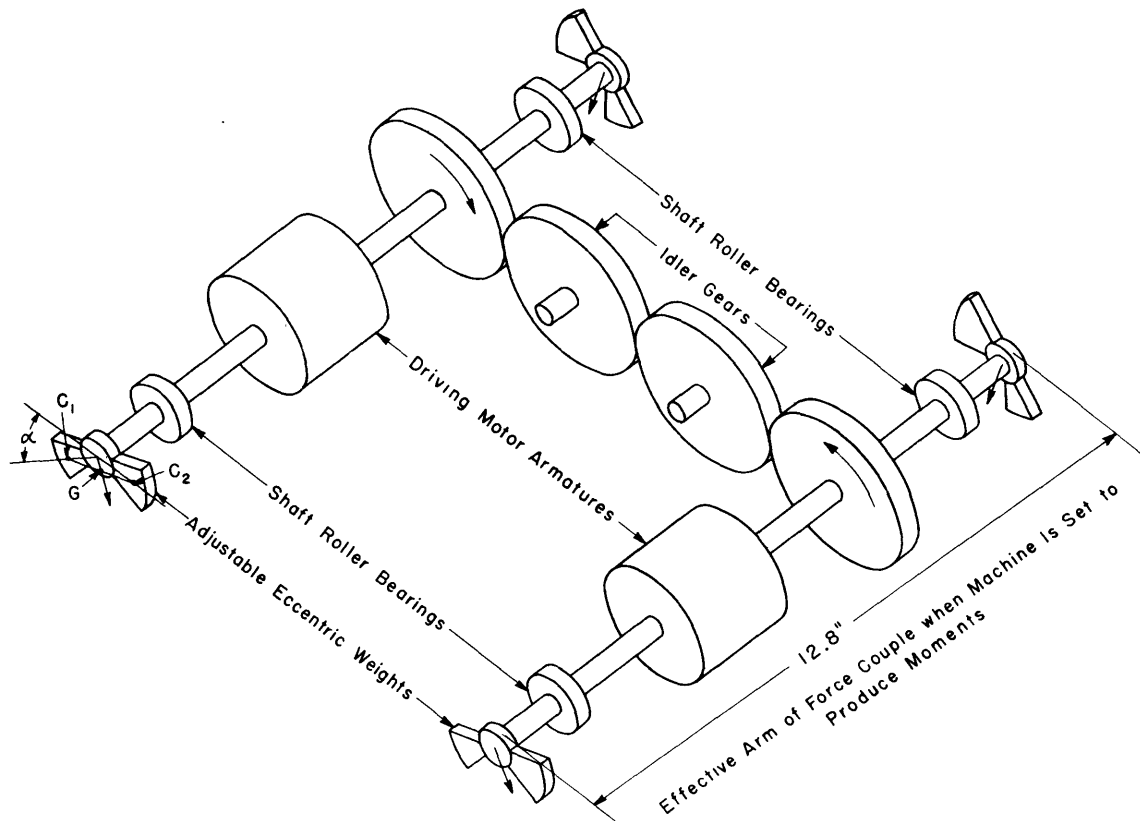

Figure 1 - Schematic Arrangement of Small Losenhausen Vibration Generator

Two shafts driven by two d-c shunt motors are geared together so as to rotate at the same speed in opposite directions. Unbalance is created by shifting one of each pair of movable weights from the balanced position by the angle of setting α . The force at each shaft end created by the unbalance acts radially through the midpoint of the line joining the centers of gravity C_1 and C_2 of the two weights as shown by the radial arrows in the figure.

Tilting moments about an axis perpendicular to both shafts and lying in the plane of both shafts is obtained by adjusting the unbalance as shown in the middle tier of views in Figure 2. To produce torsional excitation about an axis through the center of the machine and perpendicular to a plane through both shafts, the eccentric weights are disposed as shown in the lower row of views in Figure 2.

The procedure for determining the natural frequencies of the structures under investigation consists in mounting and adjusting the vibration generator to give the desired excitation, setting the weights at a relatively small angle of eccentricity, and increasing the speed gradually through the speed range. After the resonant frequencies have been determined by noting the speeds at which the maximum amplitudes of vibration occur, it is usually desirable to increase the eccentricity within the permissible range, given in Table 1 on page 18, and to run the generator at a resonant frequency while

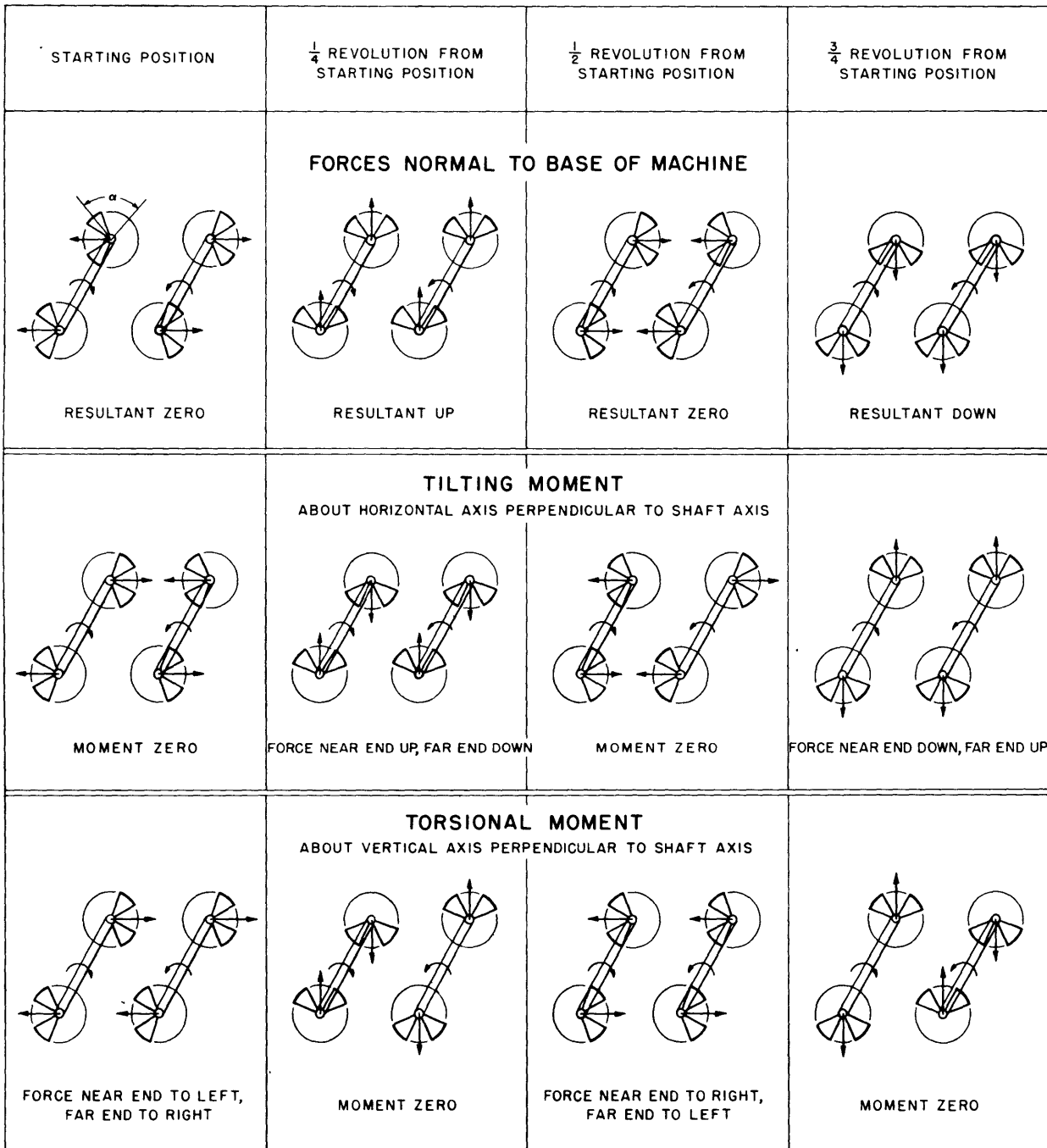

Figure 2 - Types of Periodic Forces and Moments Produced by Various Positions of Adjustable Weights

the structure is explored by suitable vibration instruments. This gives the investigator the opportunity to determine definitely the mode of vibration.

COMMON APPLICATIONS

The 440-pound vibration generator, although relatively small, can excite in their natural frequencies comparatively large structures, such as director towers of naval vessels, machinery foundations, trusses, struts, bossings, and even hulls of smaller craft.

It is possible in this way to simulate exciting forces of blade frequency* in ships, and to determine whether or not the structure under test will vibrate in resonance with these exciting forces. Forces due to unbalance can be simulated in the same manner and often machinery foundations can be classified as satisfactory or unsatisfactory even before the machine has been mounted. An opportunity is thus afforded of modifying the structure before the actual trials or tests are made in case a deficiency is discovered or a resonance is anticipated.

Setting up alternating forces in a structure generally results in flexure and in the production of corresponding strains. Because of their alternating nature these strains can be measured easily and accurately with suitable equipment (5). This enables an investigator to determine the dynamic distribution of stresses. For tests of this kind the strains that can be produced by this vibrator are limited by the damping in the structure, so there is no assurance in advance that sufficient strain will be produced for an adequate investigation.

This machine has been used successfully with sensitive amplitude meters for determining some of the natural hull frequencies and modes of vibration of craft about 170 feet long (9), but the strains produced were too small to be measured accurately with available equipment.

The machine can be attached to the end of the propeller shaft in place of the propeller and used to simulate unbalance or periodic forces caused by the propeller (4). The propeller shaft can then be turned at different angles so as to rotate the line of action of the exciting force, but unfortunately this operation can be performed only in drydock with existing equipment. Such machines have been used to apply exciting forces to a point on the ship under water while the vessel was afloat by attaching them to columns projecting below the waterline.

* Blade frequency is equal to the shaft RPM times the number of blades per propeller.

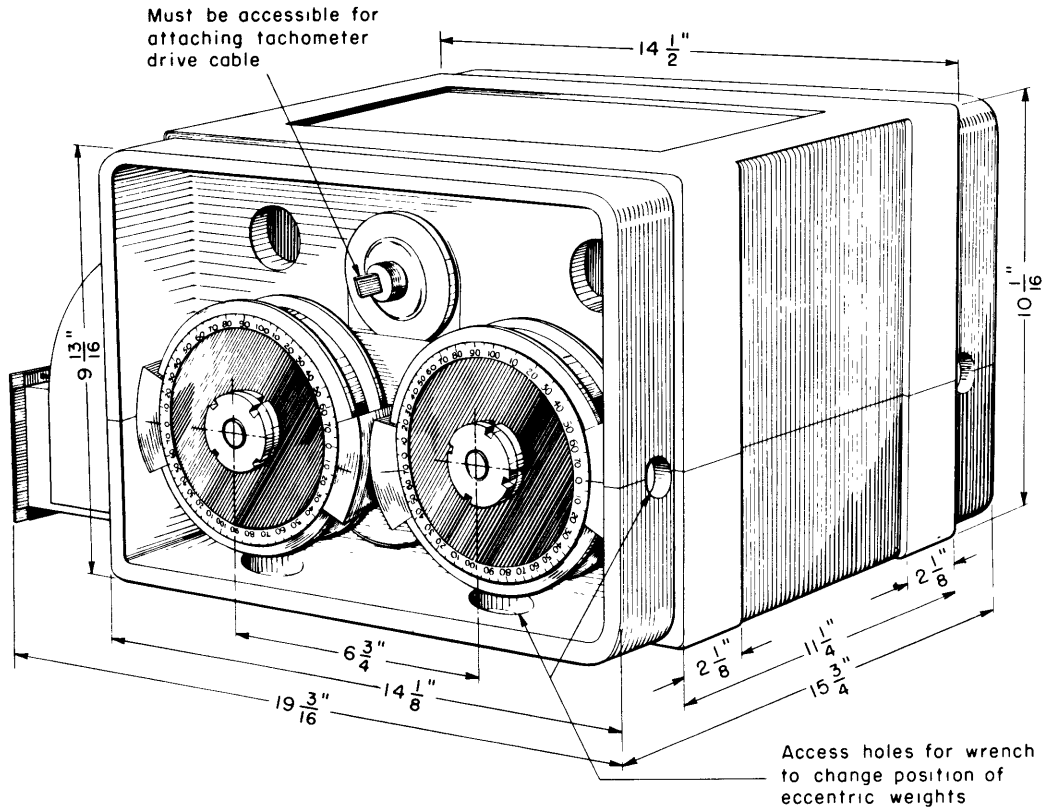

Figure 3a - General View

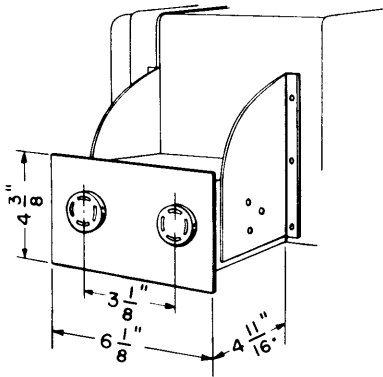

Figure 3b - Receptacle for Power Cables

Figure 3 - General View of Small Losenhausen Vibration Generator

Figure 3a is a general view of the machine and shows one of each pair of adjustable weights moved from balanced position by an angle of 10 degrees. When the disks are set in this manner on both ends of the machine the force produced will be normal to the base of the machine. Both ends of the machine and one access hole near each shaft-end disk must be accessible to change eccentricity.

The receptacle for the power cables is shown in detail in Figure 3b. It must be accessible for inserting the power line plugs.

The weight of the generator as shown here is 140 pounds.

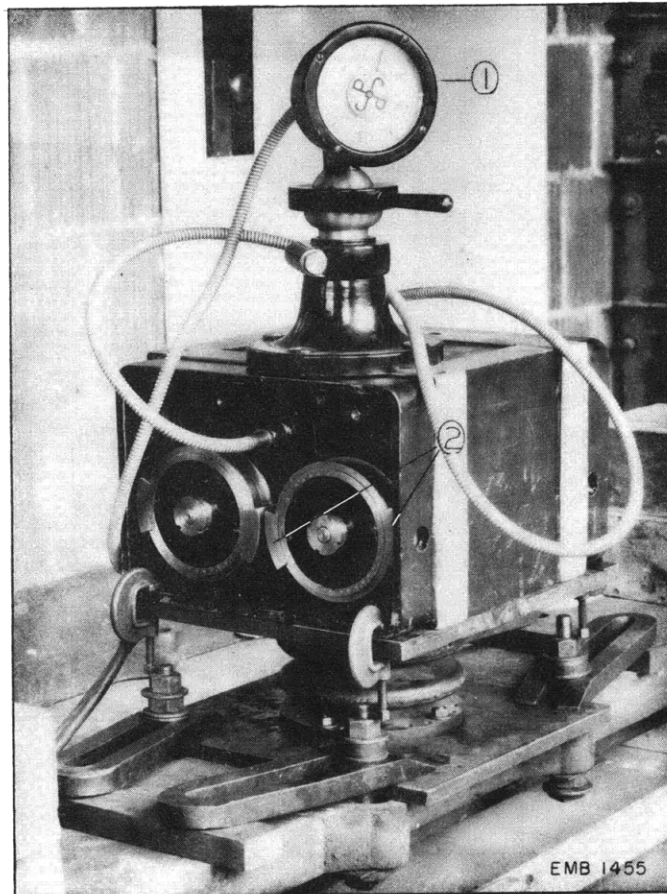

Figure 4 - Small Vibration Generator with Tachometer Shown as Received in 1931

This photograph shows the machine clamped to a rectangular plate by C-clamps. The tachometer is indicated by the numeral 1. The numeral 2 indicates one pair of adjustable weights on a shaft-end disk. Three grease fittings are visible above the shaft-end disks. The fittings have recently been replaced by a snap-on type. Two of the access holes necessary to change eccentricity are shown in the right face at the level of the main shafts.

GENERAL FEATURES

One of the important features of this machine is that it is light and portable, and of a size convenient to handle. The main frame or case is made of an aluminum alloy, and the motor field frames are of steel. Since the case has the shape of a rectangular box, the generator can easily be mounted to produce excitation in any desired direction by clamping or strapping it to the structure to be tested. A general view of the outside of the generator is shown in Figure 3. Figure 4 is a photograph of the machine and the tachometer as received in 1931; the machine and controls as used at present are shown in Figure 5.

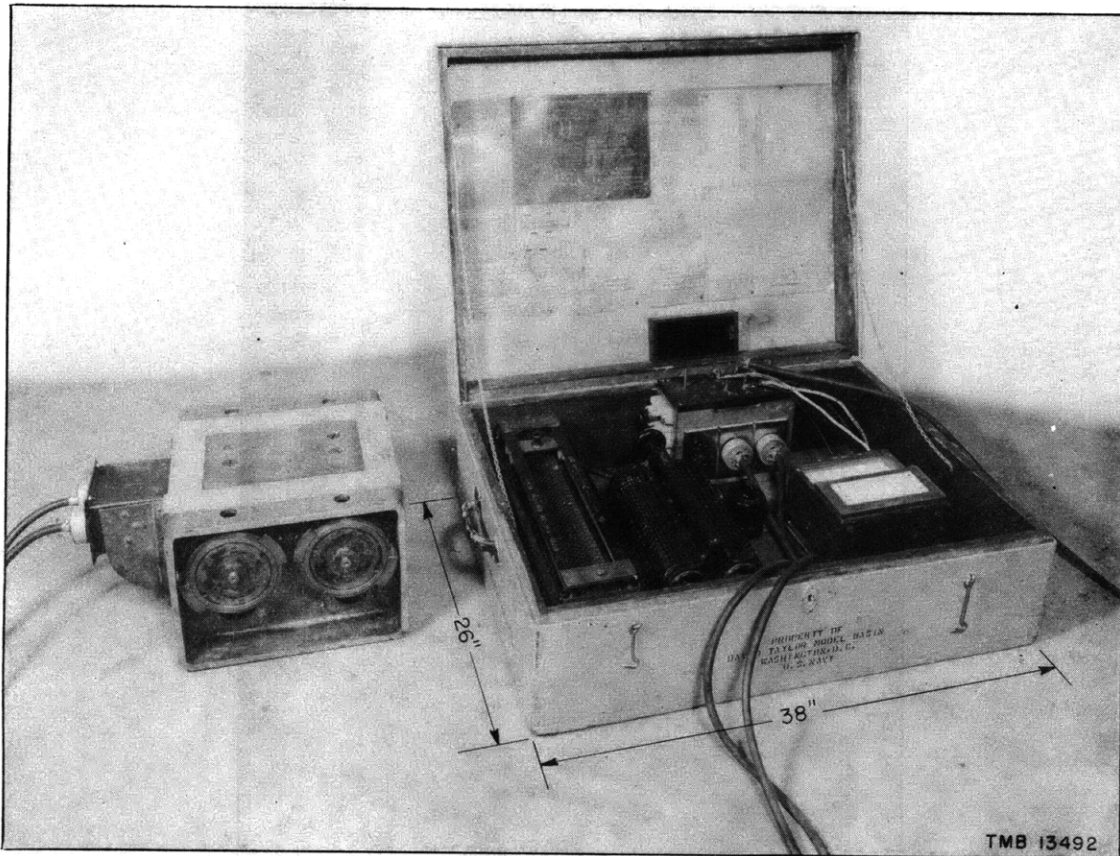

Figure 5 - Photograph of the Vibration Machine and Controls as of 1944

This photograph was taken after the train of idler gears and the idler-gear cartridge had been replaced. The original grease fittings were replaced with the snap-on type shown.

A plan view and a sectional elevation are shown in Figure 6. A view of this machine with the top part of the frame removed is shown in the photograph, Figure 7, where the two integral motors, the four helical idler gears, and all other parts are visible. If the backlash in the idler gears is allowed to increase as the gears wear, so much power may be absorbed at certain critical speeds that it is difficult to get through these speeds. The bearings on the main shafts are mounted in cartridges and are lubricated through grease fittings.

The angle through which each weight is shifted from the balanced or 180-degree position is called the angle of setting. Since each weight occupies a 45-degree sector on the disk, the maximum angle of setting is 135 degrees. The weights are held in position by friction clamping.

The rated exciting force of this machine is 440 pounds, and its rated exciting moment, either tilting or torsional, is 230 pound-feet. These values can be obtained at speeds ranging from 850 RPM to 3910 RPM, but it has not been found practical to run at speeds above 3000 RPM because of the

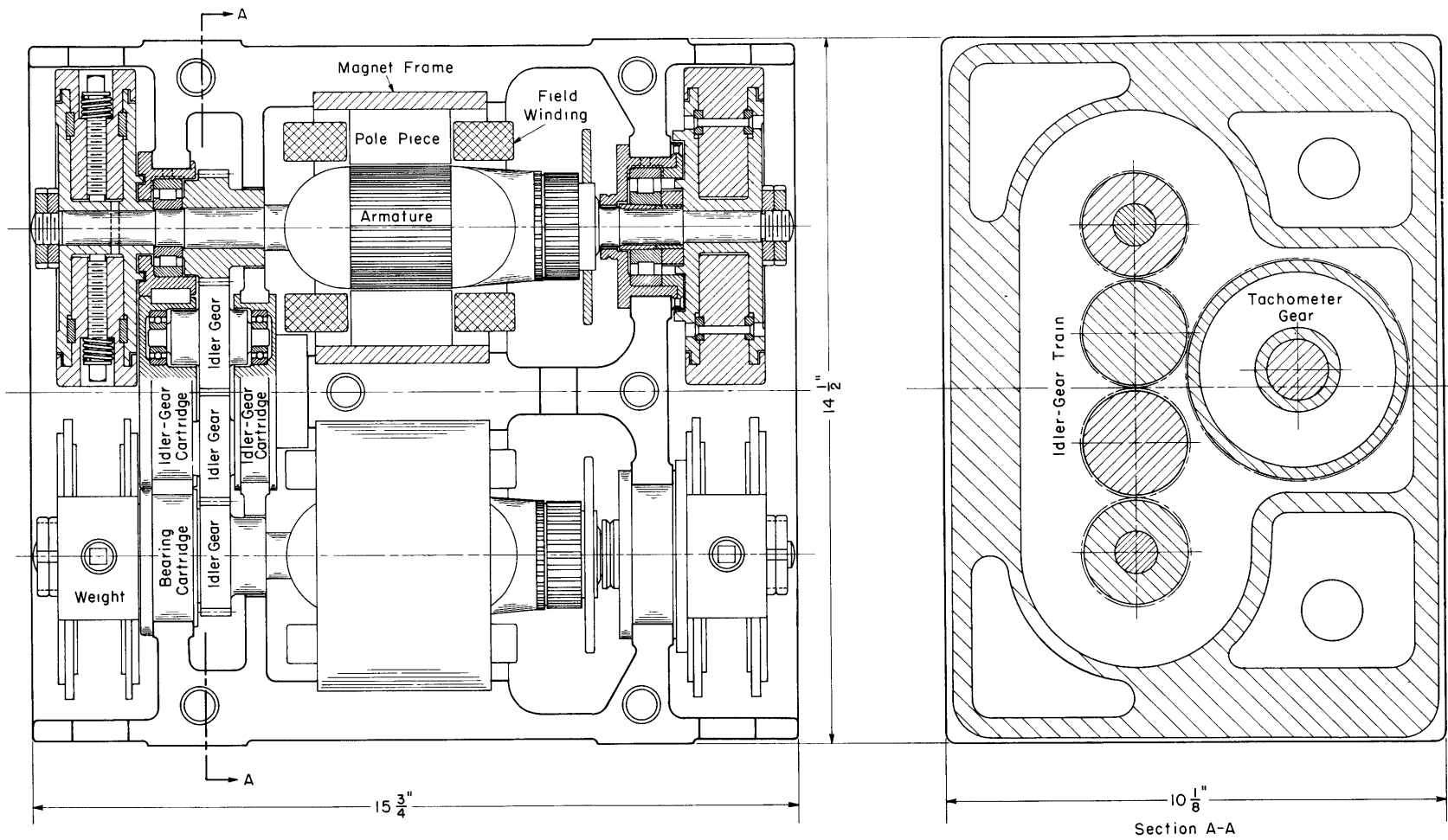

Figure 6 - A Plan View and a Sectional Elevation of the Losenhausen 440-Pound Vibration Generator

This drawing was traced from the original German plan.

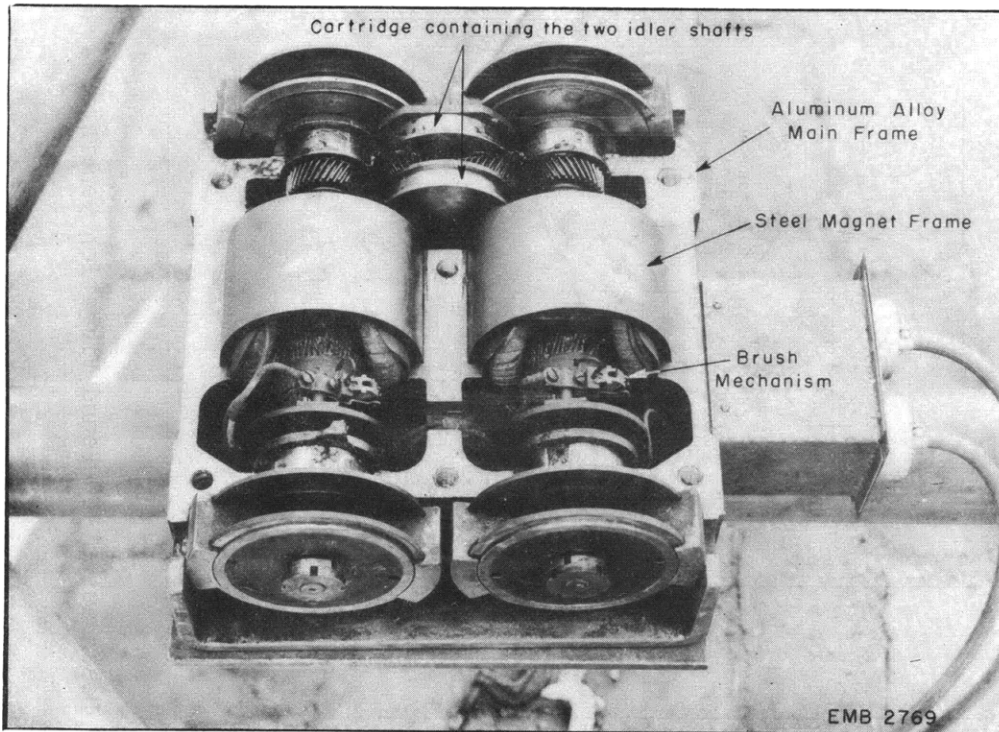

Figure 7 - Vibration Generator with Top Part of Main Frame Removed

The integral motors and brush mechanisms are visible. Note the cartridge which supports the two helical idler gears; this cartridge is capable of being rotated to take up any backlash introduced by wear in the gears. The steel-magnet or field frames are shown mounted in the aluminum-alloy main frame.

excessive electrical load on the motor controls. Below 300 RPM the motors of this machine will not produce uniform rotation if there is much unbalance.

The principal engineering data for this machine are as follows:

Overall dimensions of vibration generator	Length	19 $\frac{3}{16}$ inches
	Width	15 $\frac{3}{4}$ inches
	Height	10 $\frac{1}{16}$ inches
Overall dimensions of control box	Length	38 inches
	Width	26 inches
	Height	12 inches
Total weight of generator only		140 pounds
Weight of controls		145 pounds
Practical speed range		300 to 3000 RPM
Weight of the pair of weights on each disk		2.56 pounds
Total rated power of both motors		1 kilowatt (1 $\frac{1}{3}$ HP)
Maximum armature current of one motor		5 amperes
Eccentricity		$r = 2.28 \sin \alpha/2^*$ where α is angle of setting
Maximum eccentricity attainable		2.10 inches

* For a definition and derivation of this formula see the Appendix.

Distance of the center of gravity of each adjustable weight from the shaft center	2.28 inches
Range of angle of setting	0 to 135 degrees
Rated exciting force	440 pounds
Rated exciting moment	230 pound-feet
Weight of torsional mounting frame	185 pounds
Moment of inertia of vibrator and torsional mounting frame about axis of torsion	33 lb-in-sec ²
Approximate value of moment of inertia of vibrator about axis of torsion	3 lb-in-sec ²
Shipping weight of vibration generator	170 pounds
Shipping weight of controls	145 pounds
Shipping weight of transverse mount	155 pounds
Shipping weight of mounting bolts and clamps	90 pounds

SPEED-CONTROL APPARATUS

All vibration generators require a rather precise and stable method of speed control so that constant amplitudes may be maintained while measurements are being made. The control apparatus and a wattmeter, shown in Figure 8, are permanently mounted in a box which is suitable for shipping. The schematic wiring diagram of the circuit is shown in Figure 9.

The controls are so arranged that the incoming power may be either 110 or 220 volts d-c. Speed control is obtained by regulation of both the armature and the field voltage. From Figure 9 it is evident that the armature rheostats act as voltage dividers and the field rheostats are series resistances in the shunt fields. The armature voltage dividers are used for coarse speed control; fine variation is obtained by changing the shunt-field voltage. The armature voltage dividers are varied simultaneously by a common slider; the field rheostats are changed similarly. This affords similar control of both motors simultaneously.

The starting switch should not be turned on unless the armature rheostats are on a low speed setting such as shown in the photograph in Figure 8.

For operation on 220 volts the two armature rheostats are hooked in series so that there is a 110-volt drop available across each one. This corresponds to the hookup in Figure 9 when the incoming power is connected to terminals N and P. When 110 volts is to be used as a power source, it is supplied to the two armature rheostats in parallel so the total voltage drop across each one is again 110 volts. This corresponds to connecting the incoming power to terminals O and P and bridging N to P. Thus the same armature voltage variation is available with a source of either 110 or 220 volts. The field rheostats are connected similarly. Terminals lettered on the

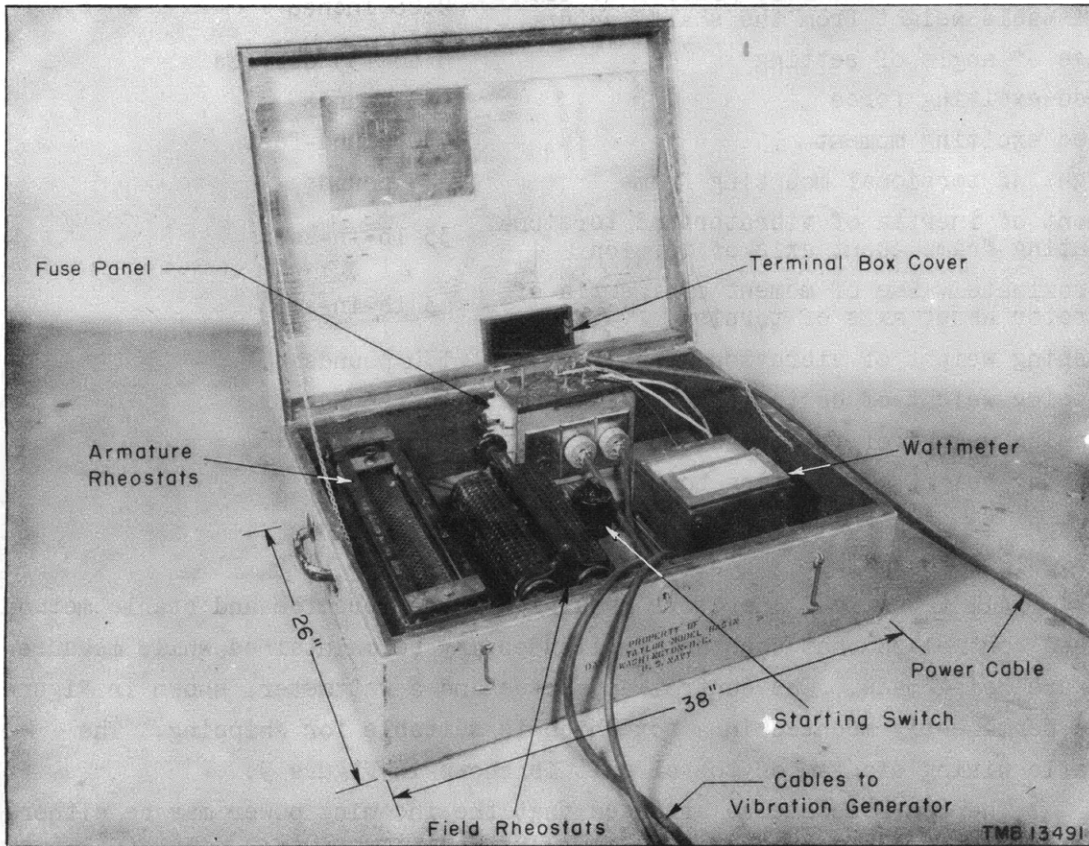

Figure 8 - Speed Control Box and Wattmeter for Small Vibration Generator

This photograph shows the control apparatus for this vibration generator, mounted in a box which is convenient for shipping. The incoming power line is shown connected to the proper terminals for operation on 220 volts d-c. When the incoming power is "on", the terminal block cover should be placed over the terminal block to eliminate accidental contact with the "hot" terminals. There is sufficient space in this box to carry the necessary cables during shipping.

diagram in Figure 9 are similarly lettered on the terminal box. The circuit carries 10-ampere fuses.

Two interchangeable 4-wire cables, each 50 feet long and equipped with polarity plugs, connect the vibration generator to the control box. As each cable carries the armature and field connections for one motor, and both motors are identical, the cables may be used interchangeably. The plugs are locked in place by turning them clockwise a few degrees; this prevents them from being loosened by vibration while the test is underway.

Terminals A and O should be bridged if the wattmeter is not used, as the hookup is designed for those terminals which are to be the current-coil connections. The wattmeter-voltage connections should be made between terminals A and C. When the wattmeter is connected as directed, it reads the power consumed by the armature of *one* of the motors.

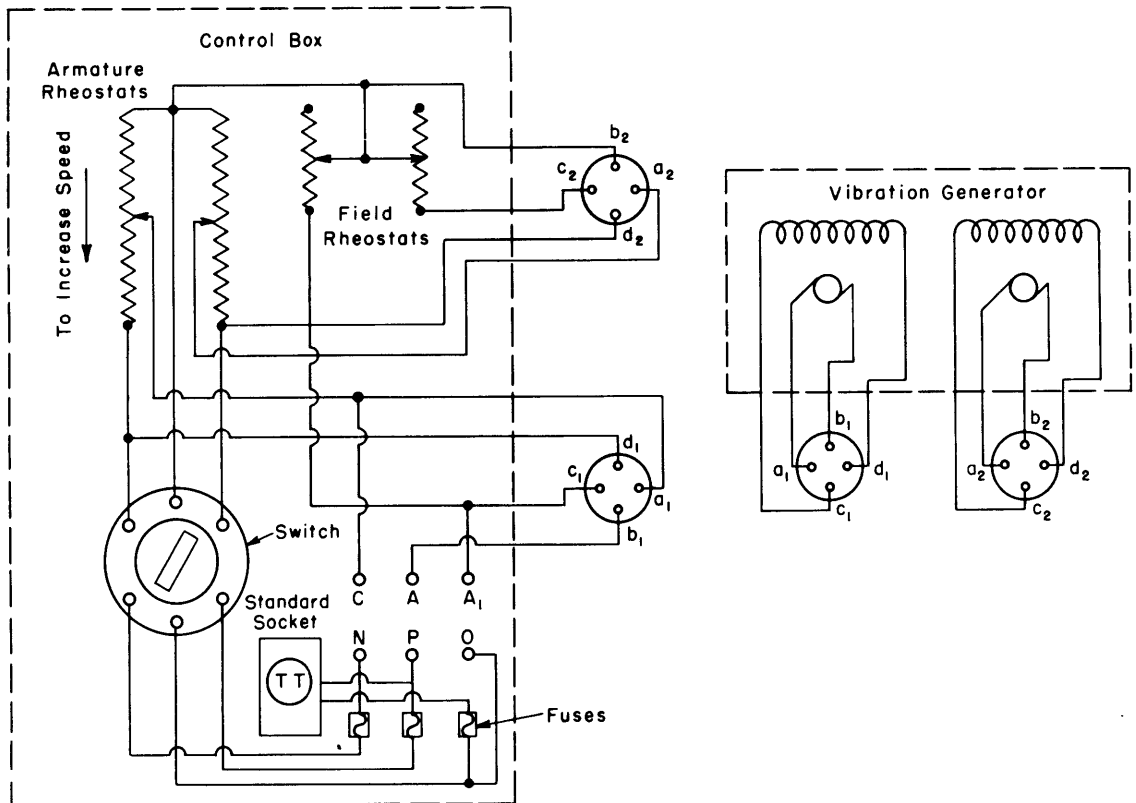

Figure 9 - Wiring Diagram for Vibration Generator and Controls

When the power source is 110 volts d.c., connect the incoming power leads to terminals O and P, or plug in standard socket, and bridge N to P with a low-resistance wire. For 220 volts d.c. connect the incoming power leads to terminals N and P without the bridge. The wattmeter current-coil should be connected between terminals A and O, and the wattmeter voltage connections should be attached to terminals A and C. When the wattmeter is not used terminals A and O must be bridged.

Two 4-wire cables, each 50 feet long, connect the control box to the machine. As each cable carries the armature and field connections for one motor, and since both motors are identical, the cables may be used interchangeably. Four-prong polarized plugs are attached to both ends of these cables. When the machine and the control box are connected by these cables, the black wire of each cable connects terminal marked a (a₁ or a₂) on the control box to the terminal designated by a (a₁ or a₂) at the vibration generator. Similarly, the white leads connect the b's, the brown leads connect the c's, and the red leads connect the d's. Plugs are locked in the receptacles by turning clockwise a few degrees after insertion.

If the armature power consumed, corrected for electrical, friction, and windage losses, is plotted on a basis of frequency, peaks should be found at resonant frequencies if the speed range has been spanned slowly. Actually, this method is not too satisfactory in practice as the additional power consumed at resonance in many tests is small compared to the relatively large running losses of this machine. Therefore, resonance is indicated by only a very small power difference which is not readily distinguishable on the ordinary wattmeter.

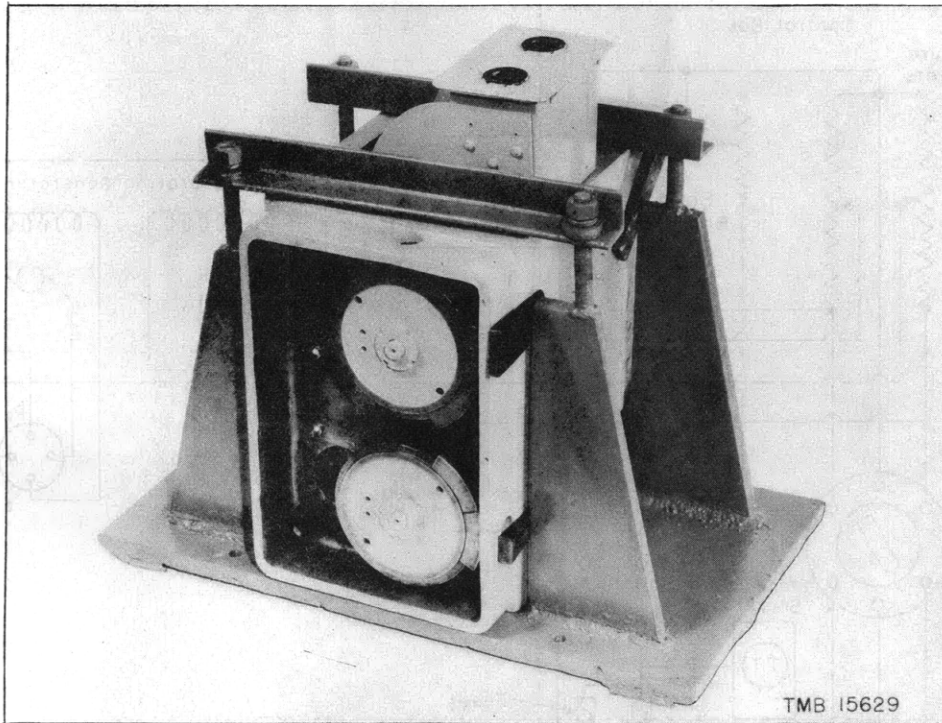

Figure 10 - View Showing the Small Vibration Generator Mounted in the Transverse Mount

This mount is used when it is desired to have the driving force applied in a direction parallel to the surface on which it is mounted. Ordinarily the mount is tack-welded in place on the structure, and is removed after the test by flame-cutting or chipping. The generator is tightly wedged into the mount to insure rigidity.

SPEED INDICATOR

As the frequencies at which resonance occurs form a principal part of the instrumental observations during a vibration test, the tachometer of a vibration generator has an important function. For this reason the machine has a precision tachometer, driven through a flexible shaft, which indicates the speed in cycles per second. Considerable trouble has been caused on this machine by the flexible shaft breaking in service. In most tests, since the amplitudes and corresponding frequency are recorded only under steady state, the frequency can be obtained more simply by a set of Frahm's reeds located on the vibrating structure, or by a hand tachometer. A Westinghouse tunable reed vibrometer also indicates frequencies satisfactorily.

INSTALLATION INSTRUCTIONS

The principal requirement for the installation of any vibration generator is that it be rigidly attached to the structure under investigation. This machine is made in the shape of a rectangular box, and it can be mounted to generate sinusoidal forces parallel to any one of its sides. This can and

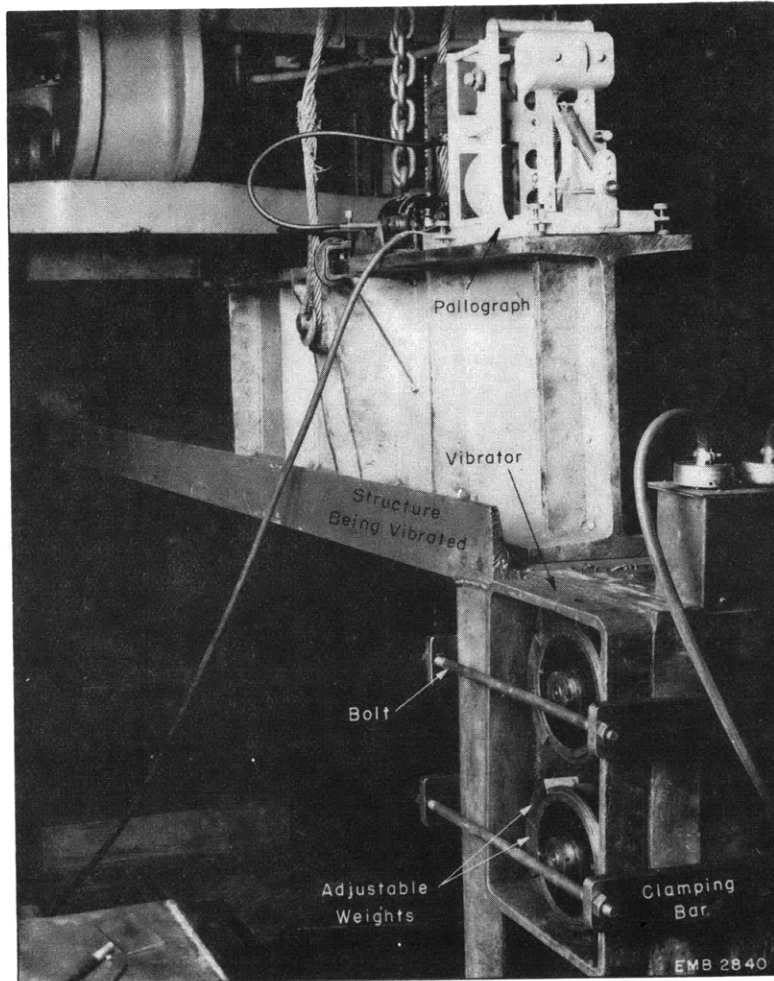

Figure 11 - Small Vibration Generator Mounted by Bolts and Clamping Bars

This photograph shows the machine attached to a structure whose horizontal motion is being recorded by a TMB pallograph. Note the relative setting of the adjustable weights on the shaft-end disks of the generator; in this case they are set for maximum eccentricity and one weight in each pair has been shifted from its balance position by an angle of 135 degrees.

should be done without blocking access to the terminal box, the wrench access holes, and the shaft ends.

If the linear force to be generated is parallel to the plane of the surface on which the generator is mounted, it can be clamped to a transverse mount which can in turn be welded or bolted in the desired position, as shown in Figure 10.

Bolts with clamping bars can be used to hold it in place by clamping, as in Figure 11, or it may be mounted with C-clamps as shown previously in Figure 4. Figure 12 illustrates a mounting fixture used (9) when torsional vibration is desired. This fixture may be mounted on the shaft end or inserted as a coupling.

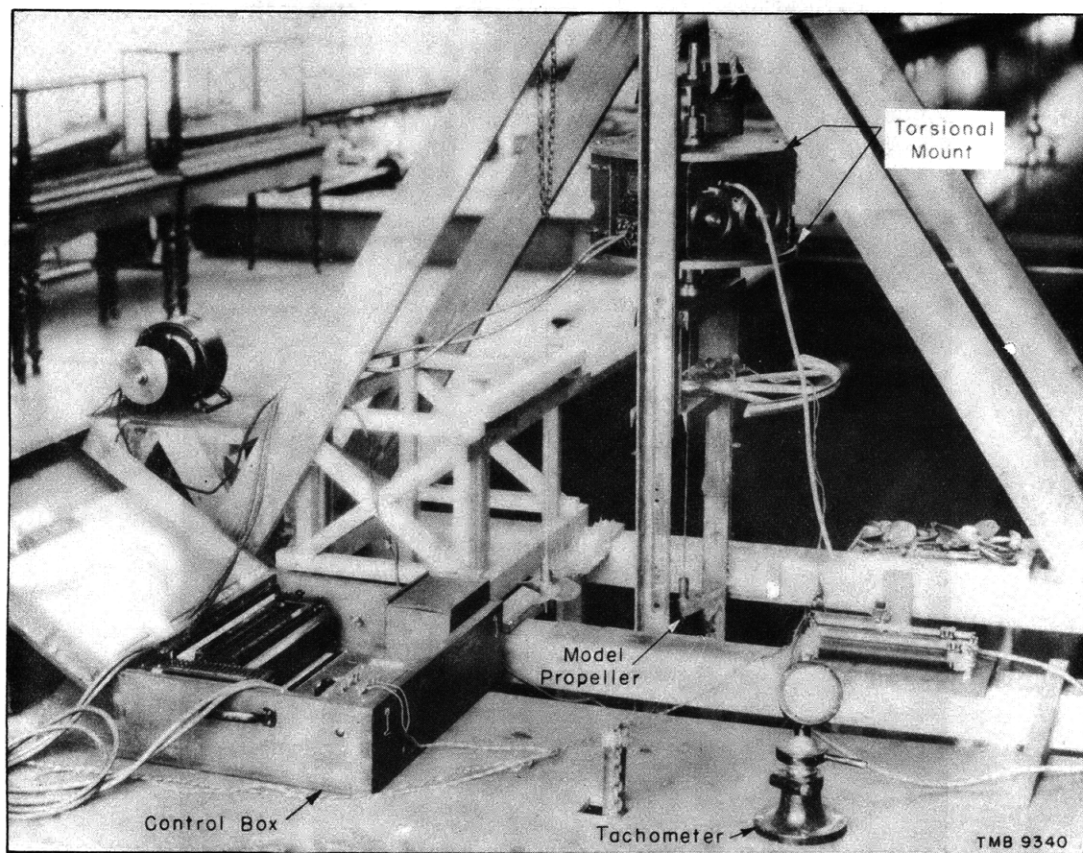

Figure 12 - Small Vibration Generator Mounted in Fixture Used for Torsional Excitation of Model Propeller

The control box and cable connections are shown as they were when received in 1931. The vertical model-propeller shaft is supported in the truss in the background. The model propeller can be seen at the lower end of the shaft, while the torsional mounting fixture with the generator mounted in place is shown in the upper part of the shaft between the two upper bearings. This mount weighs 185 pounds.

TEST PROCEDURE

To set the eccentricity, the weights should be shifted to obtain the desired direction of force or moment, as determined from Figure 2. The desired angle of setting for the required unbalance can be determined from Table 1 or estimated readily from the characteristic force curves in Figure 13.

It should be remembered that one weight of each pair must remain on zero index setting, and that the angle of setting is the angle by which the other weight of the pair is shifted from its balance position. Since each weight occupies a 45-degree sector of the disk, the maximum angle of setting of 135 degrees occurs when the two weights are adjacent.

Each weight is clamped in position in the disk by a bolt whose axis is radial to the disk and which passes through the center of the weight. A T-handle wrench can be inserted through an access hole in the edge of the

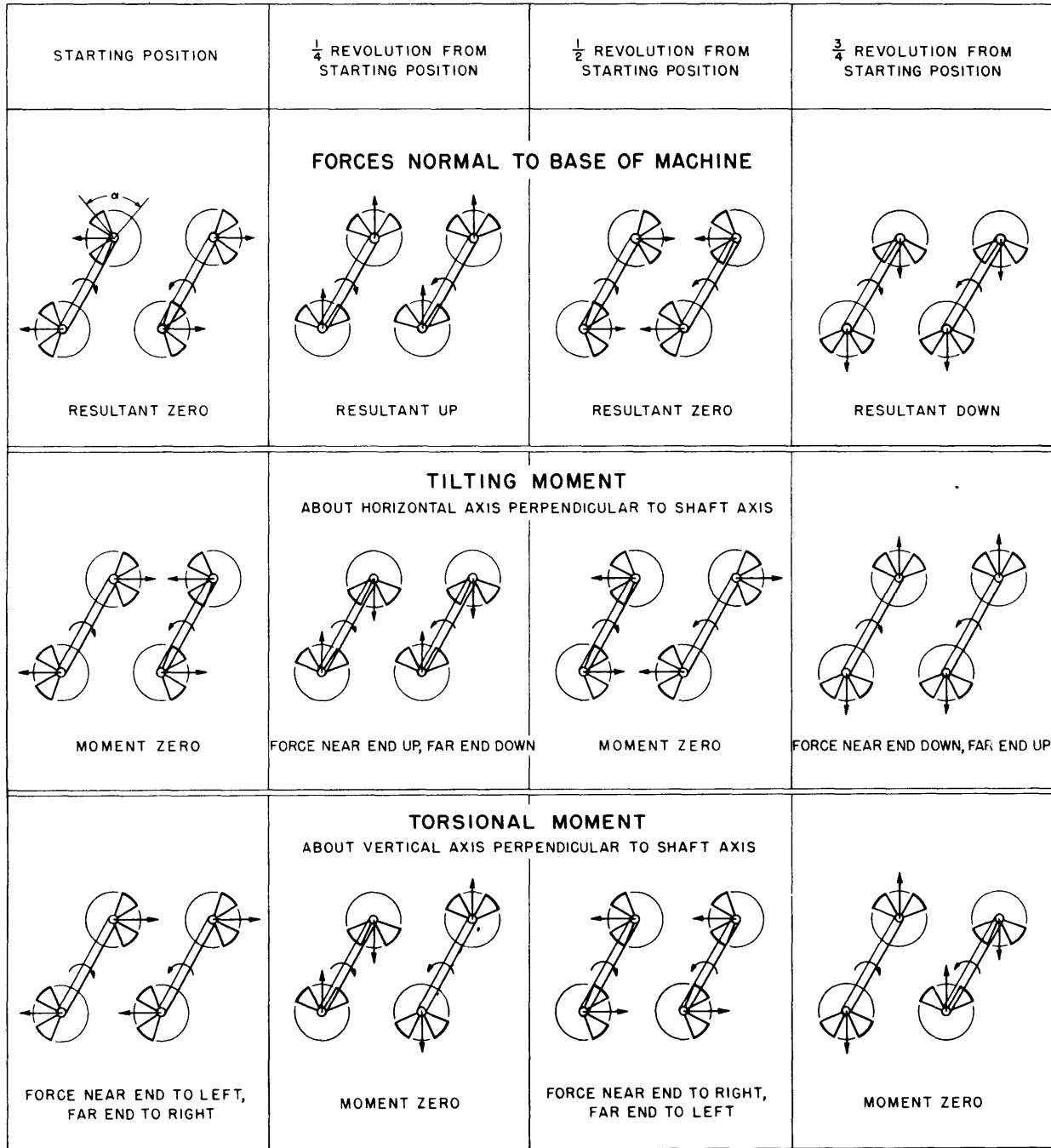

Figure 2 - Types of Periodic Forces and Moments Produced by Various Positions of Adjustable Weights

TABLE 1

Eccentricity and Speed at Which Rated Driving Force
Is Developed for Various Angles of Setting*

Angle of Setting degrees	$r = 2.28 \sin \frac{\alpha}{2}$ inches	kr	Speed at Which Rated Force Is Developed	
			RPS	RPM
0	0	0	65.2	3910
5	0.099	0.104	65.2	3910
10	0.199	0.208	45.9	2760
15	0.298	0.312	37.5	2250
20	0.396	0.415	32.6	1960
25	0.492	0.516	29.2	1750
30	0.589	0.616	26.7	1600
35	0.685	0.717	24.8	1490
40	0.778	0.814	23.2	1390
45	0.869	0.910	22.0	1320
50	0.962	1.01	20.9	1250
55	1.05	1.10	20.0	1200
60	1.14	1.20	19.2	1150
65	1.22	1.28	18.5	1110
70	1.31	1.37	17.9	1080
75	1.39	1.45	17.4	1040
80	1.46	1.54	16.9	1020
85	1.54	1.61	16.5	991
90	1.61	1.69	16.2	969
95	1.68	1.76	15.8	950
100	1.74	1.83	15.6	931
105	1.81	1.89	15.2	915
110	1.86	1.95	15.0	901
115	1.92	2.01	14.8	888
120	1.97	2.06	14.6	876
125	2.02	2.12	14.4	865
130	2.06	2.16	14.3	856
135	2.10	2.20	14.1	848

frame to unlock the weight to be moved; see Figure 3. The disk is then rotated until the index on the weight is opposite the desired angular graduation on the disk, following which the weight is clamped in position.

The speeds at which the maximum exciting force is developed are also given in Table 1. The value of kr in the table, multiplied by $(\frac{RPM}{60})^2$, gives the value of the exciting force in pounds. The moment developed is equal to half the exciting force generated at that speed, times the fixed moment arm of 1.07 foot (12.8 inches); see Figure 1.**

* The method of determining the values given in this table is explained in the Appendix.

** The moment produced is due to a couple of which half the total exciting force produced by the vibrator is the magnitude of each force of the couple, and the moment arm is the distance between the parallel planes which contain the lines of action of the forces generated. The moment arm of this machine is 12.8 inches.

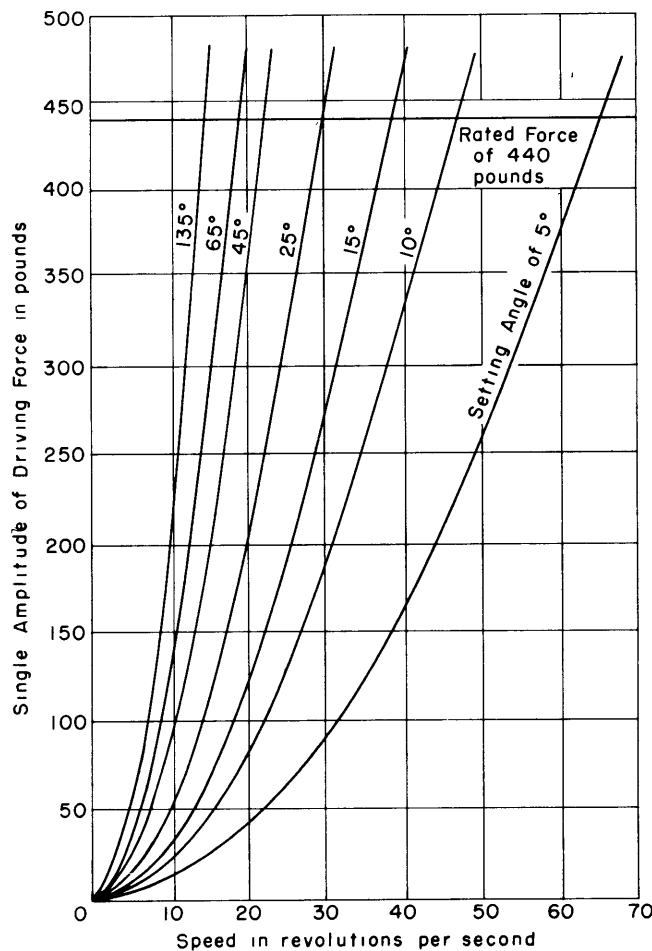

Figure 13 - Curves of Driving Force Plotted on Speed for Various Angles of Setting of the Eccentric Weights

OPERATING PERSONNEL

A test requires the service of at least two technicians, one to operate the machine and the other to take the instrumental observations on the structure being tested. It is necessary to have communication between these two persons during a test; sound-power telephones are found convenient for this purpose.

LUBRICATION

The machine has a total of five snap-on grease fittings for a push-type hydraulic gun. These supply grease to the main bearings and the idler-shaft bearings, and should be supplied with a light cup grease. A hand grease-gun is carried in the shipping box.

TOOLS

The only tools necessary for the machine itself are a T-handle wrench which is used to set eccentricity, and a heavy screw driver which is necessary to disassemble the machine. On a given test additional hand tools may be required, depending on the manner in which the vibration generator is to be mounted.

REFERENCES

- (1) "Rein dynamische Verfahren zur Untersuchung der Beanspruchungen von Bauwerken" (Purely Dynamical Methods of Investigating Structural Stresses), by R. Bernhard, Der Stahlbau, Heft 6, 1929.
- (2) "Theorie und Praxis der Schwingungsprüfmaschinen" (Theory and Practice of Vibration Testing Machines), by William Späth, Ph.D., Julius Springer, 1934; EMB Translation 51, March 1938.
- (3) "Construction and Operation of the Losenhausen 44,000-Pound Vibration Generator," by E.O. Berdahl, TMB Report in preparation.
- (4) "Vibration Test on Shaft Bossing of USS HAMILTON (DD141) at Norfolk Navy Yard, June 11, 1931," EMB Report 305, July 1931.
- (5) "Some Experiments in Stress-Relieving Castings and Welded Structures by Vibration," by Mr. R.T. McGoldrick and Captain Harold E. Saunders, USN, Journal of the American Society of Naval Engineers, Vol. 55, No. 4, November 1943.
- (6) "Strain and Vibration Measurements on an Intermediate Shaft Strut of DE49," by R.T. McGoldrick, TMB Report R-179, June 1943.
- (7) "Vibration Tests on USS HAMILTON (DD141) at Washington Navy Yard," by R.T. McGoldrick, EMB Report 372, December 1933.
- (8) "Construction and Operation of the Taylor Model Basin 5000-Pound Vibration Generator," by E.O. Berdahl, TMB Report 524, April 1944.
- (9) TMB letter S87-19/A11-(1) of 9 May 1944 to Chief of the Bureau of Ships, Research (330).

APPENDIX

DERIVATION OF ECCENTRICITIES, FORCES, AND MOMENTS

Consider one weight to be moved from its balance position by an angle α , as shown in Figure 14. Assuming C_1 and C_2 as the center of gravity of the respective weights, the resultant center of gravity G of the two weights will fall on a line joining C_1 and C_2 . Since the weights are identical, G will be at the midpoint of the line $\overline{C_1C_2}$. The distance of G from the center of rotation is the effective eccentricity r of the two masses about the center of rotation.

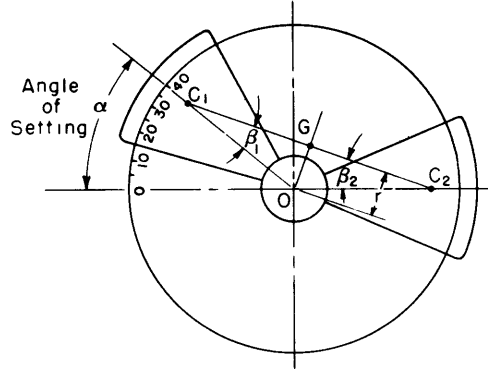

Figure 14 - Diagram Showing Position of Eccentric Weights and the Center of Gravity

Physically $\overline{C_1O} = \overline{C_2O} = 2.28$ inches; therefore

$$\beta_1 = \beta_2$$

and since

$$\alpha = \beta_1 + \beta_2$$

then

$$\beta_1 = \frac{\alpha}{2}$$

The eccentricity

$$\begin{aligned} r &= \overline{OG} = \overline{C_1O} \sin \beta_1 \\ &= \overline{C_1O} \sin \frac{\alpha}{2} \\ &= 2.28 \sin \frac{\alpha}{2} \end{aligned}$$

When α is a maximum of 135 degrees the maximum available eccentricity of 2.10 inches is obtained.

Any unbalanced mass while rotating sets up a force

$$F = m_e r \omega^2$$

where F is the force in pounds,

m_e is the unbalanced mass in pound-seconds² per inch,

r is the eccentricity of the unbalanced mass about the center of rotation in inches, and

ω is the angular velocity of rotation in radians per second.

In this machine the speed of rotation is read in revolutions per second, and the unbalanced rotating mass $m_e = \frac{4(2.56)}{386}$. Then we can write

$$F = k r (\text{RPS})^2$$

where $k = 4\pi^2 m_e = \frac{4\pi^2 \times 4 \times 2.56}{386} = 1.05$ pound-seconds² per inch.

$$F = 1.05 r (\text{RPS})^2$$

where RPS is the speed of rotation in revolutions per second. When speed is measured in terms of RPM then

$$F = 1.05 r \left(\frac{\text{RPM}}{60} \right)^2$$

$$= 2.91 r (\text{RPM})^2 \times 10^{-4}$$

When the machine is set to produce torsional moments or tilting moments, the moment of the force couple is equal to half the driving force multiplied by the fixed arm length of 1.07 foot. Therefore

$$M = 1.07 \frac{F}{2} = 0.534 F$$

where M is the single amplitude of the tilting or torsional moment in pound-feet.

MIT LIBRARIES

DUPL



3 9080 02754 0498

