

PROJECT WHIRLWIND

(Device 24-x-3)

SUMMARY REPORT NO. 23

SECOND QUARTER, 1950

Submitted to the  
OFFICE OF NAVAL RESEARCH  
Under Contract N5ori60  
Project NR-048-097

SERVOMECHANISMS LABORATORY  
MASSACHUSETTS INSTITUTE OF TECHNOLOGY

Cambridge 39, Massachusetts  
Project DIC 6345

## TABLE OF CONTENTS

	<u>Page</u>
FOREWORD	4
1. QUARTERLY REVIEW (AND ABSTRACT)	5
2. SYSTEM ENGINEERING	6
2.1 Development of WWI	6
2.2 Checking	7
3. CIRCUITS AND COMPONENTS	9
3.1 Five-Digit Multiplier	9
3.2 Vacuum-Tube Life	9
3.3 Component Replacement in WWI	12
4. ELECTROSTATIC STORAGE	15
4.1 Tube Program	15
4.2 Storage-Tube Development	15
5. INPUT-OUTPUT	19
5.1 Preparation of Punched Paper Tape	19
5.2 Computer Communication with Punched Tape and Typewriter Terminal Equipment	20
5.3 Eastman Reader-Recorders	22
6. MATHEMATICS, CODING, AND APPLICATIONS	24
6.1 Programming the Input Problem	24
6.2 Conversion Display	25
7. ACADEMIC PROGRAM IN AUTOMATIC COMPUTATION AND NUMERICAL ANALYSIS	27
8. APPENDIX	29
8.1 Reports and Publications	29
8.2 Professional Society Papers	30
8.3 Visitors	31

## FOREWORD

### Project Whirlwind

Project Whirlwind at the Massachusetts Institute of Technology Servomechanisms Laboratory is sponsored by the Office of Naval Research under contract N5ori60. The objectives of the Project are the design and development of an electronic digital computer of large capacity and very high speed, and its application to problems in mathematics, science, engineering, simulation, and control. At the present time project resources are about equally divided among (1) test, maintenance, and checking methods in the computer; (2) design, construction, and test of terminal equipment; and (3) electrostatic storage.

### The Whirlwind Computers

The Whirlwind computer will be of the high-speed electronic digital type, in which quantities are represented as discrete numbers, and complex problems are solved by the repeated use of fundamental arithmetic and logical (i.e., control or selection) operations. Computations are executed by fractional-microsecond pulses in electronic circuits, of which the principal ones are (1) the flip-flop, a circuit containing two vacuum tubes so connected that one tube or the other is conducting, but not both; (2) the gate or coincidence circuit; (3) the electrostatic storage tube, which uses an electron beam for storing digits as positive or negative charges on a storage surface.

Whirlwind I (WWI), now being built, may be regarded as a prototype from which other computers will be evolved. It will be useful both for a study of circuit techniques and for the study of digital computer applications and problems.

Whirlwind I uses numbers of 16 binary digits (equivalent to about 5 decimal digits). This length was selected to limit the machine to a practical size, but it will permit the computation of many simulation problems. Calculations requiring greater number length will be handled by the use of multiple-length numbers. Rapid-access electrostatic storage will have a capacity of 32,000 binary digits, sufficient for large classes of actual problems and for preliminary investigations in most fields of interest. The goal of 20,000 multiplications per second is higher than general scientific computation demands at the present state of the art, but is needed for control and simulation studies.

### Reports

Quarterly reports are issued to maintain a supply of up-to-date information on the status of the Project. Detailed information on technical aspects of the Whirlwind program may be found in the R-, E-, and M-series reports and memorandums that are issued to cover the work as it progresses. Of these, the R-series are the most informal, the M-series the least. A list of the publications issued during the period covered by this Summary, together with instructions for obtaining copies of them, appears in the Appendix.

## I. QUARTERLY REVIEW (AND ABSTRACT)

Electrostatic storage was connected to the rest of the Whirlwind computer in June, a few weeks in advance of the date anticipated in the first quarterly report for 1950. We are very pleased with the early results. After a very short testing period, error-free operation of a program for over an hour was obtained using electrostatic storage completely independent of test storage. The program has operated successively in all of the available 256 registers with varying degrees of reliability. Before any useful computation can be undertaken, we must improve reliability and trouble-location techniques. It seems reasonable, however, to look forward to the beginning of application studies with the computer during the next six months.

The Eastman film reader-recorder has been operated with the computer both for recording and reading. We have found the reading operation to be more difficult. Operation has not been error free. Recent modifications, which have not yet been tested with the computer, give promise of great improvement.

Routine marginal checking of the whole computer has been accomplished in about 15 minutes daily. If low margins indicate the desirability of correcting incipient trouble, additional time is taken for this work. Voltage variation is now being applied successively to each of 125 lines in these daily checks.

Analysis of tube life data from the five-digit multiplier has been extended from the previously reported 10,000 hours to 15,000 hours. At this point, 74 percent of 7AK7 tubes and 57 percent of 7AD7 tubes remain in service. These are the two tube types most commonly used in the Whirlwind computer.

We have maintained a low shrinkage rate in the production of storage tubes. During the quarter, the shrinkage for all tubes, including replacements for the computer and research tubes, was 9 percent. We are now using a demountable vacuum system for depositing the silver signal plate on the back of the mica dielectric. We have also made successful

beryllium mosaics on this system, which results in a great reduction in glass work.

Early this year it was expected that storage tubes of essentially the present model (100-series) but with shorter throw and finer mosaic would operate reliably with  $32 \times 32$  density. Thorough testing has shown that these new model tubes will not meet this specification. We therefore began, early in the quarter, to make a thorough study of some of the second-order effects in tube operation including square-to-square capacitance, distribution of holding, writing, and reading charging currents, and the effects of varying the many operating conditions. It is too early to report on the complete results of these investigations. It appears, however, that small changes in the storage tube together with changes in the operating conditions should result in reliable operation with  $32 \times 32$  density and possibly less than 10 microseconds access time. We hope to report more fully in the next quarterly report.

Equipment for preparing punched paper tapes for inserting information into Whirlwind storage has been completed and tested. We have revised the plan for reading tapes into the computer in order to make this possible sooner. By deferring the design and construction of relay registers and pulse control equipment which was to handle paper tapes in a manner similar to Eastman film control, and instead making the computer provide the control, we will have a workable interim system in operation in August.

Programming the input problem is discussed in a general way in Section 6. The conversion of orders and numbers into binary form and the selection and adaptation of automatic subroutines will be done by the computer by means of a so-called initial program.

Also described in Section 6 is a program for the conversion of binary numbers to any desired base, and a display of the resultant arabic numerals on a scope. This program produced some curious results which should be fascinating to those with an interest in the theory of numbers.

An expanded graduate-school academic program in Automatic Computation and Numerical Analysis is to be offered in 1950-51 by the MIT Electrical Engineering Department. A description of the various subjects is given in Section 7.

## 2. SYSTEM ENGINEERING

### 2.1 DEVELOPMENT OF WWI

For the past year the system engineering group has concentrated on separately perfecting each of three parts of the final WWI system; (1) arithmetic element, test storage, and central control; (2) Eastman reader-recorder input-output system; (3) electrostatic storage. During the second quarter of 1950, integration of these three into a complete system was begun, the reader-recorder being connected in first, and the electrostatic storage later.

#### 2.1.1 Development of Electrostatic Storage System

Electrostatic storage was connected to the rest of the computer at the very end of the period. After less than two weeks spent on preliminary tests, a repetitive computing program was run using electrostatic storage completely independent of test storage. Means were not available for using all of the 256 registers in the 16 storage tubes without manually altering the program, which used only 13 registers. Error-free operation of the program for over an hour was possible on some parts of the storage surfaces; use of other parts resulted in errors after five minutes.

The program used in this test computed the powers of  $x$  as described in Sections 2.2 and 6.25 of Summary Report 20. The program was initially set up in the toggle switches of test storage and read from these into electrostatic storage. The last order in test storage is a sub-program order which transfers control to the first order in electrostatic storage; after this, operation is completely under the control of electrostatic storage and independent of test storage.

It is very gratifying that this degree of trouble-free operation was possible after such a short time spent on integrating electrostatic storage with the rest of the system. Nevertheless, much work remains to be done before the computer can be expected to handle more elegant or useful problems. Changes which may result in more reliable operation are described in Section 4.2. Marginal checking of the storage system must be more thoroughly worked out. Check and trouble-location programs which have been devised for this part of the computer must be proved in practice.

Early in March, testing of the storage system was confined to one or two digit columns at a time, each containing one storage tube. These tubes, as

previously described, are 100-series tubes each capable of storing 256 points. During the period, digits were gradually added until the full complement of 16 were under simultaneous test. No new problems resulted from putting in the additional digit columns. Considerable time was spent on finding optimum operating conditions for all digit columns, and improved methods of lining up the tube circuits were devised. All this work was done with test control, which limited tests to the somewhat artificial conditions of cycling various patterns through the tubes. When an appropriate degree of reliability had been achieved, the storage system was connected to the rest of the computer. This resulted in much greater flexibility in testing, since any desired sequence of reading and writing at arbitrary points on the tubes could be set up by appropriate programs in test storage.

#### 2.1.2 Reader-Recorder Operated with System

Progress on the Eastman reader-recorder has made it possible to operate this unit first as a recorder taking numbers from the Whirlwind system at high speed, and then as a reader inserting numbers into the Whirlwind system from film made in the first operation. The experience of these first tests shows quite definitely that reading is more difficult than recording. This is mainly due to the relatively low signal-to-noise ratio involved in the operation of reading signals photoelectrically through the developed film. Several display programs that had been recorded were reread and plotted on the Whirlwind display scope. These displays were not free from error, however, and considerable work is necessary to improve the reliability of the reading and recording system so that error-free operation can be expected.

The checking system for the input-output circuits and the reader-recorder has worked successfully as designed. Trouble-location techniques developed to study the expected possible sources of error seem adequate. A method of block forming has been successfully installed which allows block spaces between groups of numbers to be any desired length under the control of the Whirlwind system. Marginal checking also has been made available to the Eastman unit, and several circuits were shown to demand further attention because of marginal operation.

In an effort to improve the signal-to-noise ratio of the reading operation, and to make line-by-line operation less marginal, a set of masks is being prepared which will reduce the density of the recorded information by a factor of two. If this should

result in much more reliable operation, the consequent reduction in speed does not seem to be out of the question, as there are few applications in which the speed of 2000 lines per second would be essential.

The next month will be spent in improving the low-margin operation of the reading and line-by-line operations, with the Eastman unit separated from the Whirlwind system. After these improvements have been made, a second testing period of recording and reading will be started.

#### 2.1.3 Program for the Next Six Months

During the next six months, intensive testing will be carried on with emphasis at first on the integration and reliable performance of electrostatic storage with the final system. Two shifts will continue to operate the system 15 hours a day. It appears that electrostatic storage should be working well enough during this next six-month period to permit preliminary tests on applications of the computer in which real-time computation speed is necessary.

The rest of the effort toward an operating computer will be devoted to terminal equipment. During August, facilities will become available for filling the computer storage from punched tape. Later in the period the first Eastman reader-recorder will have been sufficiently improved so that it will give reliable operation with the system and provide a means for rapidly filling the computer storage. Work will have commenced on the design of control circuits for the magnetic tape units.

## 2.2 CHECKING

### 2.2.1 Results of Routine Marginal Checking

During the past quarter the Whirlwind system, including test storage, has been subjected daily to routine marginal checking. These checks use the automatic voltage-variation facilities in conjunction with the solution of a special check program (Test Program II; see Summary Report 20). The time required for checking some 125 lines now in use is about 15 minutes if no low margins are encountered. The voltage excursion for each line has been set at the value which causes no errors with good components. Deteriorated components are quickly detected.

When the daily checks were initiated, relays in the marginal-checking switching apparatus did not operate reliably. The installation of plastic relay covers together with a relay maintenance schedule has resulted in great improvement. Otherwise the

marginal-checking equipment has proved satisfactory.

Marginal checking has maintained a high level of reliability for the WW system. All operation of the computer has provided continuous checks on reliability. Rarely have there been interruptions because of component failure. Those failures which have not been anticipated by marginal checking have mostly occurred during starting of the computer after it has been shut down; they have been simple to locate and repair.

Additional work is being carried on toward improving the efficiency of the marginal-checking system. This program will probably reduce the number of voltage-variation lines needed and should provide a more sensitive distinction between slight deterioration in many components and marked deterioration in single components.

### 2.2.2 Design of Check Problems

A check problem is any problem given to the computer for the sole purpose of detecting failures in the machine. By implication then, the solution to the problem must be known in advance and the computer must be instructed not only to obtain a solution but also to check its solution against the known solution (or against another solution obtained by the computer in some entirely different way). Actually, many of these problems are not problems at all in the ordinary engineering or mathematical sense but are merely sequences of operations which the machine is instructed to follow.

The ultimate goal in designing check problems is to obtain a single coded program which requires a minimum of computing time and storage space but which cannot be correctly performed unless every component of the computer is functioning properly. In this respect, a distinction must be made between a check problem, which checks as many circuits as possible at each step to reveal the presence of any malfunction, and a trouble-location problem, which checks as few circuits as possible at each step in order to locate the source of the error which the check problem has already detected. A check problem must be used frequently, hence it must be short. A trouble-location problem is needed less frequently and is part of a manual procedure, so that brevity, although desirable, is not essential.

Achieving the ultimate goal of a short, efficient, overall check problem is probably easier said than done. The voltage-variation equipment greatly simplifies trouble location (through localization) and increases the effectiveness of checking (by precipitating weak circuits into failure and

thereby greatly reducing the errors, intermittent or otherwise, occurring during actual computations). But voltage variation does not simplify the task of designing an overall check problem.

Basically, the design of such a problem requires the synthesis of many simple problems, each checking a small part of the computer, into a unified, efficient whole. The synthesis can be attacked in two quite different ways:

1. By direct synthesis, in which first the computer is subdivided into many groups of circuits (probably the same groupings already determined by the voltage-variation line assignments), and then separate check problems are written for each group and these problems are pieced together into one overall problem.
2. By a cut-and-try method, in which a problem that seems to check many circuits is first written and then analyzed to determine which circuits are actually checked and which are not. A new problem which attempts to include circuits previously omitted is then written and analyzed.

There are two important difficulties with the direct synthetic approach. First, the design of each separate component problem is tedious work, often open to serious omissions and other errors. It seems hardly possible to work out on paper all of the ways in which groups of circuits may fail. Even assuming that only one component will fail at any one time (the single-failure hypothesis), the prob-

lem is not an easy one. Second, even after all of the component problems are written, one can hardly expect to *string them all together and get a problem of feasible length*. Any component problem is bound to check some circuits besides those for which it was designed, and the strung-together problem is likely to be extremely redundant.

The primary difficulty with the cut-and-try approach is simply that the analysis of a given problem is extremely lengthy. Each of the myriad possible failures must be considered separately to see whether the problem under consideration would detect it. If the analysis had to be performed only once, there would be no serious objection. But a problem which seems to check a great deal is likely to have many omissions, so that many guesses and consequently many analyses may be needed.

Most hopeful is a compromise procedure, in which a problem is written by cut-and-try to check as much as possible, and this problem is then lengthened to include all omissions by direct synthesis. The difficulty here is to know when to switch from one approach to the other.

Detailed work along both the direct and the cut-and-try approaches has been and is being done. At the same time, actual data is being obtained by routine daily and weekly observations on the computer using incomplete problems of both types to gain experience and empirical evidence. It seems certain that the result of such labors will be a check problem of reasonable length which will provide a fairly complete check on all of Whirlwind I.

## 3. CIRCUITS AND COMPONENTS

### 3.1 FIVE-DIGIT MULTIPLIER

The five-digit multiplier (a prototype of the Whirlwind arithmetic element) has completed 15 months of operation on an extended life test in which studies of system reliability are being made. The system is set up to perform repeated solutions of the product  $31 \times 31$  and to check each solution. If errors occur, they are recorded on electromechanical counters to give a measure of the system reliability. The repetition rate for the problem is 15,000 times per second, or over one billion multiplications a day. The aim of the work is to determine what are typical sources of error in a computing system and to discover the most effective methods of finding and eliminating potential sources of error.

Multiplier performance during the past quarter has not been quite as good as during the preceding nine-month period. The chart on page 10 gives a summary of operation for the period April through June 1950. This shows a total of 41 error counts, or about six times as many as the average for the three previous quarters (not counting periods when errors occurred continuously). From April 1 to May 29, only six errors were recorded. Thirty-three of the counts occurred between May 30 and June 11. During this period considerable maintenance work was being carried out, and no thorough checks were made at the end of a working day to determine whether the system had satisfactory operating margins for the overnight runs. Many of these errors were the result of the maintenance activity in progress.

The need for this major maintenance has been indicated by marginal checking data for more than six months. The work (a total of about 60 hours) consisted principally of balancing flip-flops, and involved removal and resoldering of components as well as replacing tubes. Substantial improvements in operating margins were obtained as a result of this work. In addition, two potential sources of intermittent errors were located. One of these was a loose strand of wire lying across a tube socket in such a way that excessive vibration would cause a short circuit between two pin connections and produce an error signal. The other was an unsoldered connection in the test-equipment control circuits which occasionally caused faulty operation of these circuits. It is almost certain that these two potential error sources have existed since the start of the reliability run, but it is impossible to determine if they were the cause of any of the unexplained

errors which occurred in the past.

Routine marginal checking on the multiplier has been performed on each working day to detect deteriorating components. Totals of 27 tubes and 13 crystal rectifiers were replaced during the quarter. These represent about 7 percent and 1.5 percent respectively of the total numbers of these components which are in use.

The data which have been obtained during the multiplier reliability test indicate that marginal checking is an effective means for preventing the occurrence of errors which would result after gradual deterioration of components. The majority of the errors obtained are of a random and isolated nature, and no satisfactory method for locating their sources has been found. Many intermittent faults which could cause such errors have been discovered by painstakingly examining the equipment and by tapping the various elements on each panel. Although this procedure has resulted in a substantial improvement in system reliability, its success is largely a matter of chance, and no assurance can be obtained that the last remaining fault has been eliminated.

### 3.2 VACUUM-TUBE LIFE

Information on vacuum-tube life is being gathered principally from three sources: (1) operation of the five-digit multiplier, (2) operation of the Whirlwind computer, and (3) controlled life tests on tubes. Since a relatively large number of tubes (3000) have been in service in the Whirlwind computer for more than 3000 hours, it is felt that records on these tubes as well as those in the multiplier (18,000 hours operating time) will shortly become the best available source of tube-life data in the project.

#### 3.21 Five-Digit Multiplier

In the quarterly report for the period January through March 1950 (see Summary Report 22) were curves depicting the life characteristics of three types of vacuum tubes used in the five-digit multiplier. Of these types — 7AD7, 7AK7, and 6AS6 — the 7AD7 and 7AK7 are used extensively in the Whirlwind computer. Although the multiplier had been in operation over 15,000 hours at the time the report was written, the curves were extended only to the 10,000-hour point so that there could be no misinterpretation of the less significant points which would be obtained for life greater than 10,000 hours. At the present time the multiplier has accumulated about 18,000 hours of operating time, and it is felt that the data are significant for carrying the plots out to 15,000 hours.

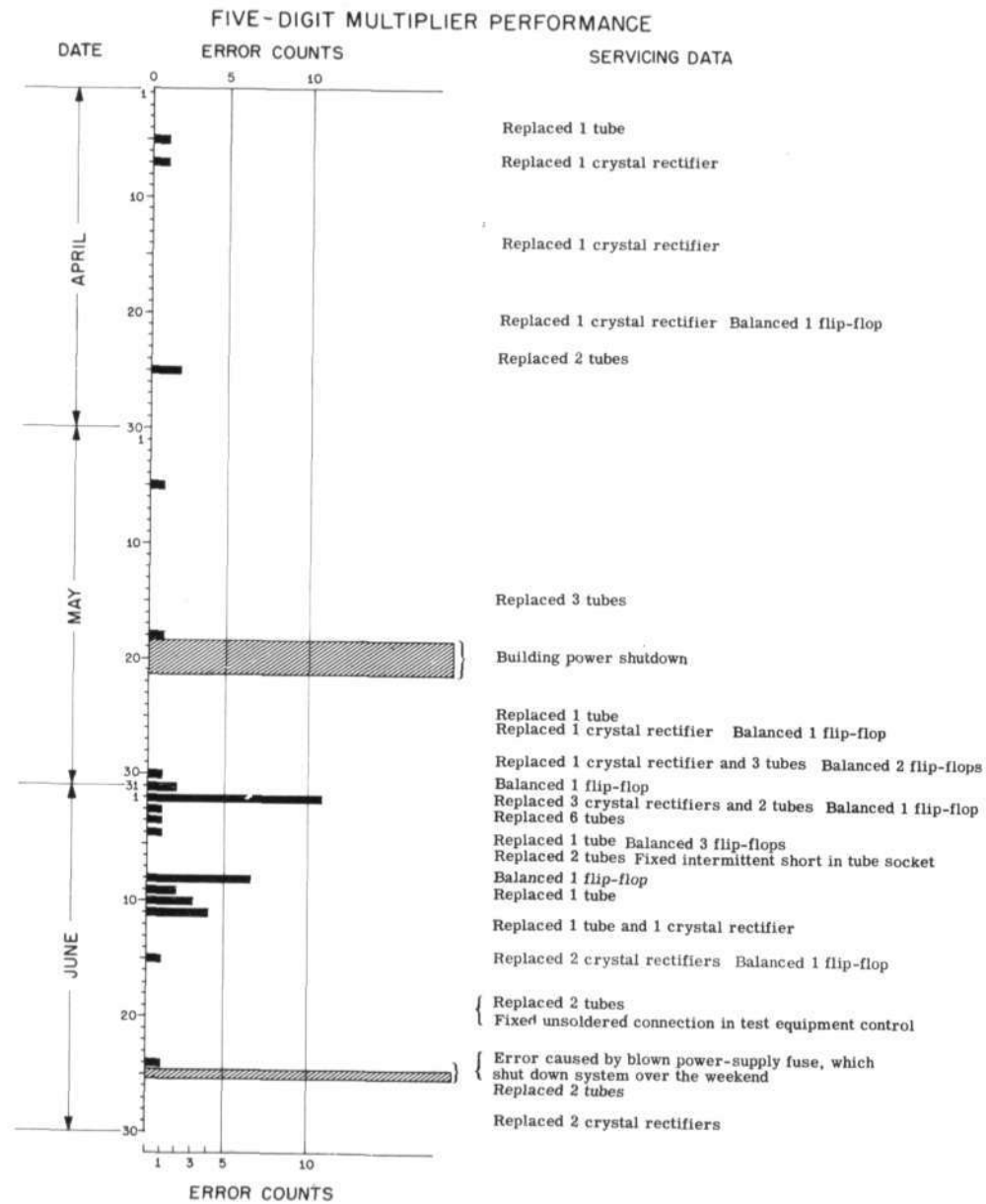

The method of obtaining plotted points is the same as was used for the graph of tube life in Summary Report 22. In order to include information from both the original and the replacement tubes in one graph, care must be taken in the choice of a method of data analysis. The test data are similar to those which would be available from many different lots started on test at different calendar dates. The method of analysis must properly combine the data at corresponding ages for the different lots. As for a single test lot, the results from such an analysis can be plotted as a curve of survival percentage vs. length of service. The early section of the curve is based on a larger sample of tubes than the later sections, which do not include data from so many replacement tubes.

The data are analyzed as follows to obtain the values for plotting the curve of survival vs. length of service. For each thousand-hour interval of tube life, the total number of tubes whose life reached beyond the end of the interval is noted. To this is added failures during the interval, to obtain a number of tubes at the beginning of the interval. (This procedure properly excludes from the calculation those tubes which are still alive and have reached the start of the interval but have not been in service long enough to reach the end of the interval). The number of tubes at the end of the interval is divided by the number at the beginning of the interval to

give the survival ratio,  $S_n$ , for the nth interval. A survival ratio is thereby established for each time interval of tube life. Beginning with 100 percent tubes in service at zero hours, successive points on the curve are obtained by multiplying the preceding point by the survival ratio of the next interval. Each point on the final curve may be expressed mathematically as the finite product:

$$A_n = 100 (S_1)(S_2) \dots (S_n),$$

where  $A_n$  is the percent of tubes remaining after the nth time interval and  $S_n$  is the survival ratio for the nth interval.

The accompanying curves show the life characteristics of the 7AK7, 7AD7, and 6AS6 tubes used in the multiplier. The figures in parenthesis give the total numbers of tubes on which experience has been obtained and also the numbers of socket positions in which tubes are placed. The numbers of socket positions given are larger than the figures shown in the previous quarterly report because the data include additional tubes used in test equipment.

The shape of the curves out to 7000 hours is essentially the same as for the previous plot. In the interval from 10,000 hours to 15,000 hours, the curves tend to level off in all cases, indicating that there are fewer failures among the tubes which have survived for the longer periods of time. Some

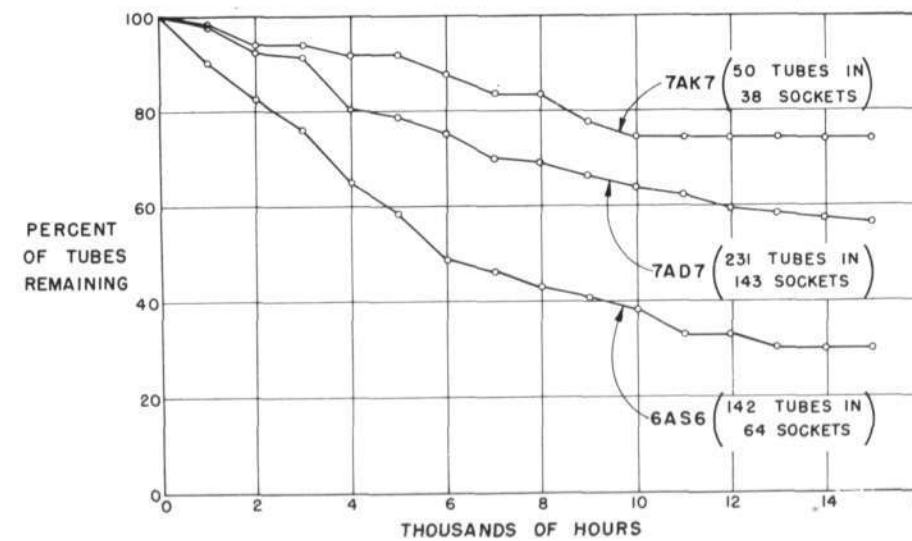

Tube life in five-digit multiplier.

reasons for the spread among the three curves are the following. The 7AK7 tubes are of special pilot-plant construction, while the 7AD7 tubes were purchased from commercial production. The 6AS6 tubes, also of commercial production, are used in circuits which do not have as wide operating margins as those for the other two types, so that less tube deterioration can be tolerated.

It can be seen that at 15,000 hours, 74 percent of 7AK7 tubes and 57 percent of 7AD7 tubes remain in service.

### 3.22 WWI Computer

At the present time the vacuum-tube complement in the Whirlwind computer totals nearly 4000 tubes, of which about 40 percent are type 7AD7 and 35 percent are type 7AK7. The majority of the 7AD7 and 7AK7 tubes have been in service for approximately 3500 hours. The performance of these two types is comparable to what has been obtained in the five-digit multiplier: the 7AK7's, which are of pilot-plant manufacture, have better life characteristics than the 7AD7's, which were obtained from commercial production. The tube failures which occurred during the past quarter are listed in the table on page 13. A total of 59 tubes were replaced, and, as for the previous quarter, the principal causes of failure were mechanical defects and changes in tube characteristics.

### 3.23 Life Tests

At the present time no research is being conducted on the deterioration of vacuum tubes through controlled life tests, although accelerated tests of this type are being used to assist in evaluating new lots of tubes that are purchased. In a report on the

research which has been conducted on vacuum-tube life over the last year and a half (R-179, Vacuum Tube Life Experience), considerable emphasis is placed on cathode-interface deterioration, and analyses of life-test results on several types of tubes are given. The following is an abstract of this report:

Experience with vacuum tubes in a prototype high-speed digital computer has brought to light an important type of deterioration, first identified in 1948, which results in an effective resistance, shunted by a capacitance, in series with the cathode of the affected tube. This deterioration is associated with the formation of an interface between the cathode core and coating. Methods of measuring this resistance, which may exceed 100 ohms, have been found, and many of its properties have been determined. Life tests have shown that vacuum tubes with cathode sleeves of "active" alloy are subject to this type of deterioration, whereas vacuum tubes with cathode sleeves of "passive" alloy are normally not. A tentative accelerated life test for determining susceptibility to this deterioration has been established. Experience with vacuum tubes in the prototype equipment has shown that reasonably long (greater than 10,000 hours) vacuum-tube life may be expected in conservatively operated tubes when the above deterioration is absent or minor in nature.

### 3.3 COMPONENT REPLACEMENT IN WWI

The number of components other than tubes and crystal rectifiers requiring replacement continues to be negligibly small. During the quarter, 79 crystal rectifiers were replaced as shown in the table on page 14. The data still gives no evidence of crystal deterioration with age.

### TUBE FAILURES IN WWI

April - June 30, 1950

Type	Total in Service	Hours at Failure	Reason for Failure; Number Failed			
			Change in Characteristics	Mechanical	Burn-Out	Gassy
7AK7	1412	0 - 100				
		100 - 500				
		500 - 1000				
		1000 - 2000				
		2000 - 3000		1		1
7AD7	1622	0 - 100				
		100 - 500		1		
		500 - 1000	4	2		1
		1000 - 2000	4	3		
		2000 - 3000	10	3		
3E29	134	0 - 100				
		100 - 500				
		500 - 1000				1
		1000 - 2000				
		2000 - 3000	7	1		
6Y6G	263	0 - 100				
		100 - 500				
		500 - 1000				
		1000 - 2000				
		2000 - 3000	3	1		
6SN7	366	0 - 100				
		100 - 500				
		500 - 1000				
		1000 - 2000				
		2000 - 3000		1		
6AG7	80	0 - 100				
		100 - 500				
		500 - 1000				
		1000 - 2000				
		2000 - 3000	1			
2D21	20	0 - 100				
		100 - 500				
		500 - 1000				
		1000 - 2000				
		2000 - 3000		1		
2C51	29	0 - 100				
		100 - 500				
		500 - 1000				1
		1000 - 2000				
		2000 - 3000				
715B	18	0 - 100				
		100 - 500				
		500 - 1000		1		
Gammatron Type 24	1	0 - 100				
		100 - 500				1

## FAILURES OF COMPONENTS IN WWI

April 1 - June 30, 1950

Component	Type	Total in Service	No. of Failures	Hours of Operation	Comments
Capacitor	0.001	2900	1	217	Open.
Crystal Rectifiers	D-357	7500	1	373	Isolating crystal; excessive drift.
			3	1000-1500	1 grid crystal; 1 clamping crystal; 1 reset crystal: excessive drift.
			8	2000-2500	7 mixer crystals; 1 reset crystal: excessive drift.
			2	2500-3000	1 grid crystal; 1 reset crystal: excessive drift.
	D-358	3040			Clamping crystals; all failed because of excessive drift unless otherwise specified.
			3	0-500	2 drift; 1 low back resistance.
			3	500-1000	
			34	1000-1500	
			5	1500-2000	1 drift; 4 low back resistance.
			14	2000-2500	
			5	2500-3000	
Delay Line	0.25 $\mu$ sec.	40	1	373	Open.
Pulse Transformer	3:1	2542	1	2739	Open primary.
Filament Transformer	Stancor #P-5012	1	1	263	Short.
Resistor Wire Wound	2000 ohms 8 watt	686	1	3200	Resistance unstable.

## 4. ELECTROSTATIC STORAGE

## 4.1 TUBE PROGRAM

Production of standard 100-series tubes for WWI continues at a scheduled rate of three per week. Shrinkage is still low, approximately 15 percent at initial test. Enough 100-series tubes are now available to provide a complete set of spares for the single bank now in WWI.

Development continues toward the design of better tubes, although a reliably operating tube with  $32 \times 32$  density has not yet been achieved.

## 4.1.1 Tube Production

The total production for this quarter was 33 storage tubes, of which 20 were standard 100-series tubes and 13 were research tubes of various

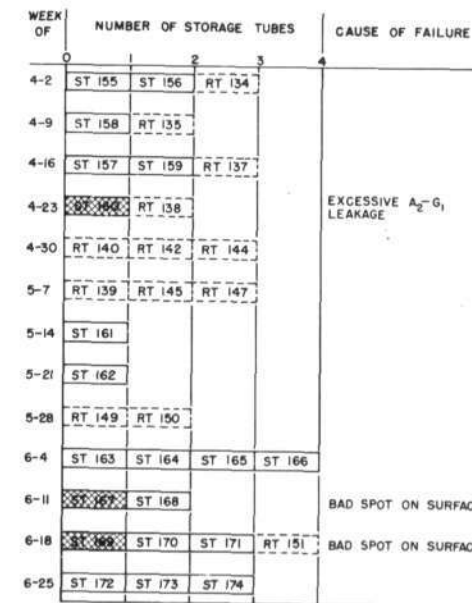

GOOD STORAGE TUBES  
 GOOD RESEARCH TUBES  
 BAD TUBES

Storage-tube production record.

types. Thirty of these tubes passed initial test, yielding a shrinkage of 9 percent, which is more than the last quarter but still very low.

All three failures were standard tubes. ST 160 exhibited excessive A<sub>2</sub>-G leakage and imploded during reprocessing. Two others, ST 167 and ST 169, showed bad surface areas with poor storage. The cause of this difficulty has not yet been discovered. The trouble is not chronic, however, since the succeeding six tubes have all been satisfactory.

The accompanying chart shows the tube production record for the second quarter of 1950. The table on page 15 describes briefly the specialized characteristics of the research tubes listed. A small number of tubes for gun studies were also built but are not listed. The research tubes are mostly designed to permit the study of the effect on tube performance of such parameters as mosaic size and spacing, mica thickness, and collector-to-surface spacing.

## 4.1.2 WW Acceptance Tests

Most of the standard storage tubes built during the quarter were actually built during June. During June the storage-tube test laboratory was moved from the third floor to the basement to provide space for the in-out equipment of WWI.

This move plus the 200-hour shelf-time requirement between initial tests and static WW acceptance test has delayed acceptance of many of the new tubes. The available tubes are divided among the following categories:

Category	Number of Tubes
In WWI	16
In mount boxes, having passed acceptance tests.	3
Passed static acceptance test but not mounted	10
Passed initial test but not yet given static acceptance test	6
Not yet tested	3
<b>Total</b>	<b>38</b>

## 4.2 STORAGE-TUBE DEVELOPMENT

## 4.2.1 Construction of Simplified Tubes

We are now using the demountable evaporation system for depositing the silver signal plate on the back of the mica dielectric. Several beryllium mosaics have also been made on the demountable system with apparent success. One of these was assembled in a 100-series tube (RT 151) and performed normally. Mosaics made in this fashion



will be carefully tested before their adoption for WW tubes. The use of the demountable system will greatly reduce the total glass work, the part construction and assembly, and the processing time that now go into storage-tube construction.

#### 4.22 Storage Density Research

There are many combinations of electrode voltages and gates with which tubes may be operated. We are now using a set of these variables which give satisfactory operation. Our present investigations are aimed at determining an improved set of conditions which will result in better operation of present tubes, as well as discovering ways in which to improve the tubes themselves.

Effort during the last quarter has been concentrated on examining the details of the writing, reading, and holding of charges on the storage surface. In the reliability tester this work has consisted of measuring the following parameters: (1) charging current distributions due to both high- and low-velocity beams; (2) spot interaction; (3) read-out signal dependence on spot size and deflection align-

ment; (4) spot stability as affected by the various electrode voltages; (5) the mechanical configurations of various research tubes; and (6) the gate lengths and amplitudes, operating speeds, and storage densities enforced on the tubes. Static testing has measured such deflection effects as defocusing, deflection-plate interception, and secondary emission as affected by angle of incidence of the striking beams. Equipment has been built to plot directly on an oscilloscope the holding-gun charging current as a function of surface potential. Calculations and measurements have been made of the capacitances between squares and between square and signal plate in order to compute capacitance charging effects.

#### 4.221 High-Velocity Gun Studies

The compensating circuits now used in the WW storage-tube mount are satisfactory for operation with 16 x 16 arrays, but it is doubtful whether they will be satisfactory for high-speed 32 x 32 operation. Improved methods have been set up for centering the high-velocity gun in the storage tube.

### CHARACTERISTICS OF RESEARCH TUBES

April 1 - June 30, 1950

Research Tube Number	Description
RT 134	Storage surface composed of 4 quadrants each evaporated through 40-mesh screen but with the following wire diameters: 0.002", 0.004", 0.0065", 0.010".
RT 135	As RT 134 but 60-mesh with 0.003", 0.0045", 0.006", 0.0075" wire.
RT 137	200-series with high-velocity and holding guns interchanged; 100-mesh mosaic.
RT 138	100-series with 0.0045" collector-surface spacing maintained by mechanical spacers.
RT 139	100-series with surface consisting of 4 quadrants each with a different mica thickness.
RT 140	100-series with 0.003" mica instead of the standard 0.006" - 0.009" mica.
RT 142	100-series with deflection plates aligned with the mosaic instead of with the collector.
RT 144	200-series; 100-mesh with 0.0045" collector-surface spacing.
RT 145	Short-throw, single-neck ST, 40-mesh, with 4 holding guns.
RT 147	100-series with storage assembly taken directly from an evaporation tube, giving zero collector-surface spacing.
RT 149	100-series with 100-mesh 0.001"-spacing mosaic.
RT 150	100-series with an additional screen in front of the collector.
RT 151	100-series with mosaic evaporated using demountable vacuum system.

These methods may remove the necessity for supplying adjustable centering voltages in each mount. Removal of the deflection sensitivity compensation will require the control of deflection-plate spacing and alignment. It may therefore become necessary to assemble our own guns instead of purchasing assembled guns as we have been doing thus far.

#### 4.222 Low-Velocity Guns

Studies made with the new equipment for measuring holding-beam charging current, as well as studies of the same effect made by other methods, indicate that only a fraction of the holding-beam current is effective in stabilizing the surface. This fraction is very dependent on the voltages on the

A<sub>3</sub> and A<sub>2</sub> anodes and the collector. By optimizing these voltages we may get a substantial increase in holding current without changing the design of the tube.

#### 4.223 Mosaic Studies

Capacitance measurements and calculations show that capacitance charging between mosaic squares has a first-order effect on square stability, particularly in finer-mesh tubes. It may become necessary to use a thinner dielectric in order to increase the square-to-signal-plate capacitance. The use of a thinner dielectric (perhaps 0.002 inch) with a closely spaced collector presents construction difficulties if spacers are to be avoided.

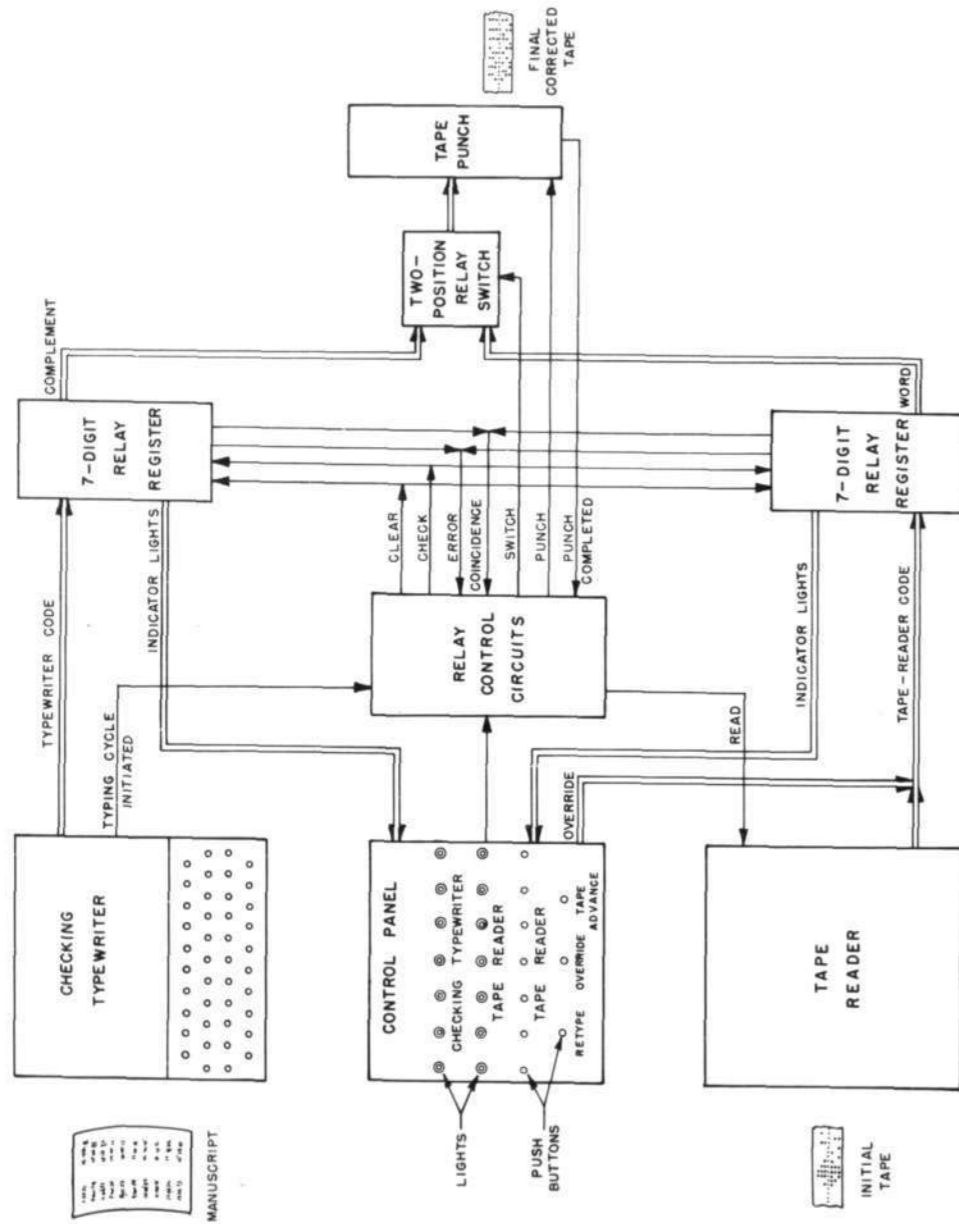

Fig. 1. Block diagram of tape-preparation system.

5. INPUT - OUTPUT

5.1 PREPARATION OF PUNCHED PAPER TAPE

The system for preparing punched paper tapes to be used for inserting information into Whirlwind storage has been assembled and has undergone initial tests. This system (outlined in Summary Report 22 and described completely in Engineering Note E-343) utilizes commercial Flexowriter typewriter and tape-punching equipment. It is designed to produce a punched tape in which (1) each character code has been checked by means of relay signals before being punched and (2) each character is represented twice, once as a standard code and once as its complement. The equipment uses a seven-hole tape (not counting the feed hole) in which six holes are required to form codes for the typewriter characters, leaving the seventh for control and synchronization purposes.

In order to accomplish the checking step in obtaining the final punched tape, it is necessary to prepare an initial tape from the manuscript by means of a typewriter-and-punch combination connected as for normal office use. When a key on the typewriter is depressed, one row of holes representing the code for that character is punched in the tape. The initial tape may contain unnoticed errors as well as errors which have been nullified by the punching out of all six holes at the place where the error was made.

The basic elements of the tape-preparation system are shown in Fig. 1. They include a typewriter, a tape reader, a tape punch, two seven-digit relay registers, and circuits for controlling the action of the reader and punch. Fundamental operation of the system is as follows. The initial tape is inserted into the tape reader. An operator working at the keyboard of the typewriter in this system (checking typewriter) copies the same manuscript from which the initial tape was made. When a key on this typewriter is depressed, signals from permutation contacts in the typewriter cause the associated seven-digit relay register to be set up with the code representing the typewriter character selected. The typing operation also initiates reading action in the tape reader. Since the initial tape may contain codes for "blank" (feed holes only) or "nullify" (all six holes punched), both of which are meaningless, the control circuits are designed to reject these words. When a code other than blank or nullify is found, control causes it to be set up in the seven-digit relay register associated with the reader and the contents of the two relay registers

are then checked for coincidence. If the check is satisfactory, the control orders punching of the word and its complement. Signals are obtained from the relay registers for setting up the punch with word and complement information in turn and are routed to the punch magnets through a two-position relay switch. When the punching is completed, the registers and control circuits are cleared and the next character may be typed. Examples of initial and final tapes are shown in Fig. 2.

Various interlocks are provided to interrupt operation when there is lack of coincidence between information set up in the two relay registers. In particular it is impossible to actuate the punch when such a situation exists. Lack of coincidence may occur because the wrong key has been struck on the checking typewriter, because of an error in the initial tape, or because of malfunction in the Flexowriter or relay equipment. The disagreement between the contents of the two registers is indicated by lights on the control panel. However, to determine

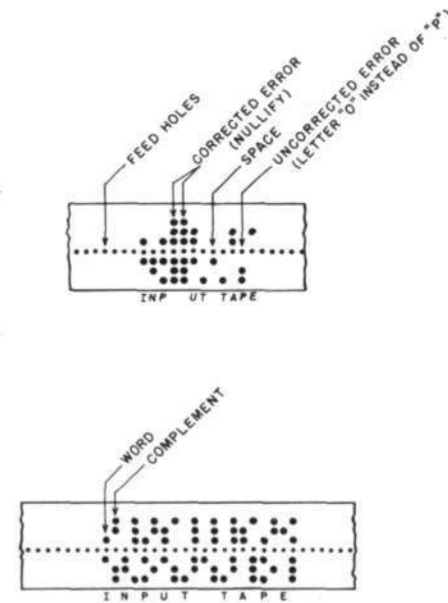

Fig. 2. Examples of punched input tapes. (Spelling the words "input tape".)

which register is in error the operator must consult a reference table and find what is the correct code for the character that is to be punched. If the typewriter register is incorrect, pressing the RETYPE pushbutton on the control panel will clear this register and allow another typewriter key to be struck. In this case the tape reader will not advance, since the last character read is the desired one, but a check will be performed, and if it is successful, punching will take place.

If it is found that the error is in the tape-reader register, the operator must press the OVERRIDE pushbutton on the control panel to clear both relay registers and then must set the proper code into the tape-reader register with the push button switches provided. The typewriter key can then be struck over and, if coincidence between the registers is obtained, the punching process is carried out. As in a RETYPE operation, the tape reader does not advance, so that synchronization between the initial tape and the final tape is not lost.

Loss of synchronization between initial and final tapes will occur if an extra character has been inadvertently punched in the initial tape. The TAPE ADVANCE push button on the control panel provides a means for regaining synchronization without manually moving the tape in the reader. Operating this push button clears both relay registers as in an OVERRIDE operation, but when a key on the typewriter is subsequently depressed the tape reader is allowed to advance and read the next character. In this manner the character on the initial tape which was superfluous is effectively disregarded.

The layout of the control circuits was planned so that the entire tape-preparation system could be assembled by plug-in cables into a self-contained unit which can be located wherever 110-volt a-c power is available. The assembly consists of a table on which the Flexowriter equipment and control panel are placed with the relay control circuits mounted beneath the table at the rear. The typewriter and tape punch may be used for preparation of the initial tape if desired by operating a manual selector switch which restores the connections between these two units to their normal conditions.

In initial tests the system has performed quite satisfactorily. However, a need is indicated for improvements which will facilitate carrying out error-correction procedures. The chief difficulty arises from the fact that there is no means for interlocking the mechanical action of the keys on the typewriter. As a result it is possible to put one or more characters onto the copy being produced by this typewriter after an error has been detected by the control, so that in some cases it might be diffi-

cult to determine at which character the error occurred. An operator will have less trouble of this sort as more operating experience is obtained, particularly if he does not attempt to work at high rates of speed. The maximum speed for preparation of corrected final tape when the initial tape contains no uncorrected errors and relatively few nullify codes is about 45 words per minute. Flexowriter equipment in normal office use has a tape punching speed of about 80 words per minute.

Most of the testing has been measurement of relay timing throughout the equipment by means of inking-oscillograph records. Variations in the timing of the relay operations which would result from changes in the a-c line voltage have been studied by varying the supply voltages from which the relays operate. Facilities are provided for separating the relays into three groups for such voltage variation so that each group may be checked independently of the other two. The data obtained show that satisfactory operating margins exist both with regard to timing and to the voltage required to energize the various relays.

#### 5.2 COMPUTER COMMUNICATION WITH PUNCHED TAPE AND TYPEWRITER TERMINAL EQUIPMENT

During the past quarter it became evident that the development work on the punched tape and typewriter terminal equipment could not be completed by the time the facilities would be needed. It was decided to interrupt this work and plan a simpler program with the aim of obtaining operating equipment by August, 1950. The initial system of punched tape and typewriter equipment (described briefly in Summary Report 22) included a tape reader for transferring data from a corrected punched tape into the computer via the in-out and comparison registers and a tape punch and a typewriter for receiving information from the computer via the same registers. As far as possible the information transfers between these registers and the terminal equipment were to be carried out in a manner similar to that employed with the Eastman-Kodak film reader-recorders. That is, the digits of a word would be shifted into and out of the registers serially and the transfers would be checked automatically in the comparison register without requiring special programming of computer orders. The control circuits for this equipment therefore were to have included pulse generators, gates, and amplifiers for accomplishing the shifting and checking as well as relay circuits for controlling the mechanical actions of the reader, punch, and typewriter units.

A major simplification of the terminal equipment just described is to be accomplished by placing all the burden of checking and control on the computer. A further simplification is to be obtained by utilizing one of the test-storage flip-flop registers instead of the in-out register for communication between the computer and the Flexowriter terminal equipment. These simplifications reduce the number of auxiliary relays needed to control the Flexowriter units and minimize the amount of pulse circuit design required.

The circuit designs for the input tape reader and output typewriter and punch have been completed. Block diagrams of this equipment are shown in Figures 3 and 4. The designs of both the input reader and the output punch are such that these units will perform a single operation upon receipt of a pulse signal from the computer and will return a completion signal to the computer at the end of the operation. The program set up in computer storage, then, determines when information is to be read in, causes a check between word and complement codes to be carried out, and forms comple-

ments for output punching if a self-checking output tape is desired. The output equipment is to be arranged so that both punched tape and typed copy may be produced simultaneously or either may be obtained alone. To obtain typed copy along with a punched tape containing both words and complements, relay circuits are used to count the punch commands so that typing takes place only on alternate punching operations.

Connections of the input tape reader to the flip-flop storage register will consist of relay contacts in series with the toggle switches now used for resetting the register. These contacts switch d-c voltages, so that there is no problem of gating video pulses.

For operating the output punch and printer, a seven-digit relay register will be set up corresponding to seven digits of the binary word in the flip-flop register. The relays will be energized by the firing of thyratrons which are controlled by the indicator-light voltages of the flip-flops. Neither the input nor the output system, therefore, disables the flip-flop register, so that it can be used in a

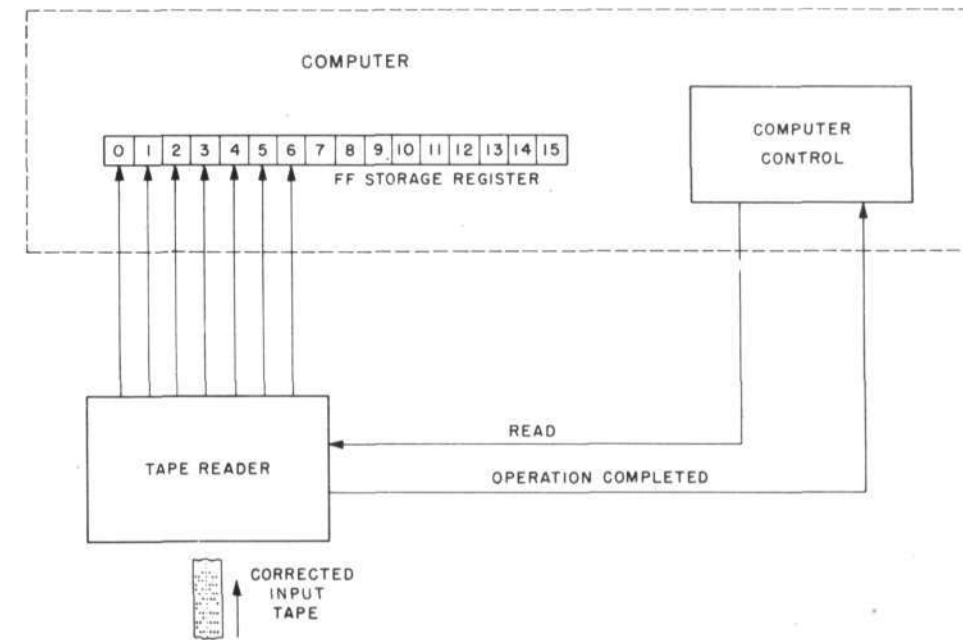

Fig. 3. Block diagram of input tape reader.

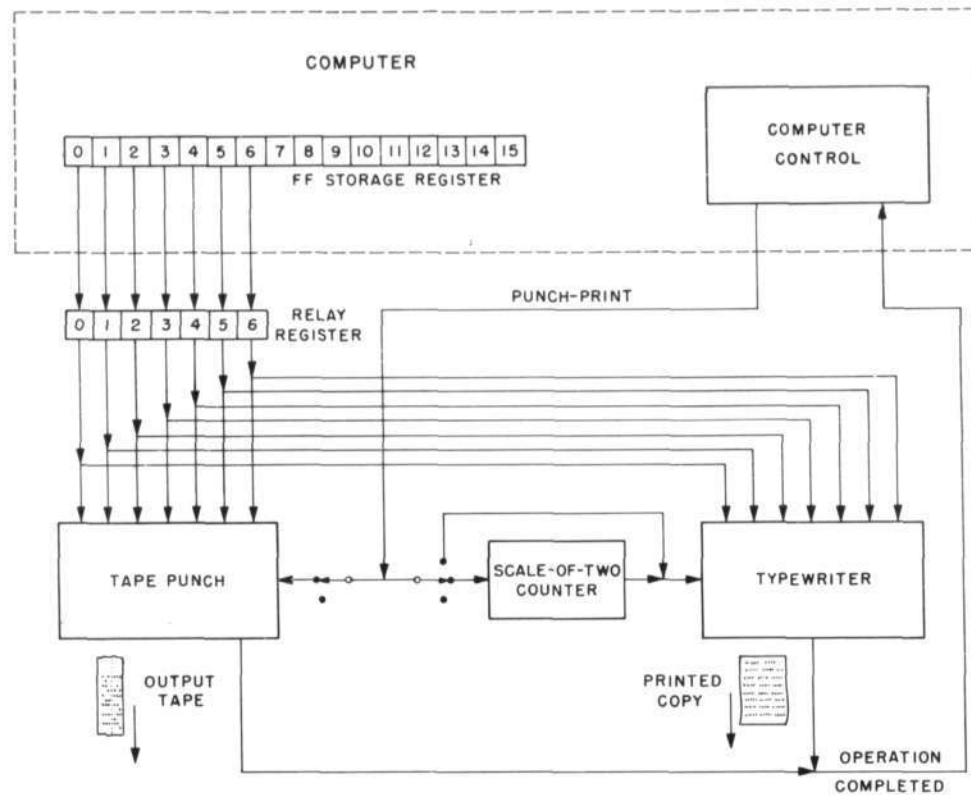

Fig. 4. Block diagram of output typewriter and tape punch.

normal manner for execution of computer orders when no input or output operations are taking place.

### 5.3 EASTMAN READER-RECORDERS

The test control does not have the facilities of the computer for starting and stopping the film in the reader-recorder or for generating changing word patterns. Therefore, in order to evaluate the operation of the film unit (particularly as a reader) under actual system conditions, plans called for a tie-in between the reader-recorder and the computer for about a month beginning at the end of May.

Before the tie-in, considerable testing was carried out using a revised test control designed to facilitate trouble location. This control permitted a cyclic operation which could be stopped at any de-

sired point in each cycle, so that effectively step-by-step operation was produced although dynamic conditions were preserved. The testing indicated that the greatest weakness in the unit was in the conversion of light signals into electrical pulses by means of the phototube circuits. Particular difficulty was experienced in obtaining an adequate signal-to-noise ratio in the reference-marker channel which controls the timing of the cathode-ray-tube sweep. Theoretically the troubles which have been encountered in converting the light signals into electrical ones could be minimized by reducing the density of information recorded on the film (using a larger spot size and increasing the distance between recorded words). Data so far available does not indicate whether the present recording density should be reduced in order to obtain reliable operation. The necessary tests will be made by means of redesigned masks.

Testing of the film unit under control of the computer progressed much more slowly than had been anticipated, since malfunctioning of the film-processing equipment made it impossible, for more than a week of the tie-in, to get satisfactory films for reading tests. The principal conclusions drawn from the test results were:

- 1) Further redesign of the reference-marker phototube circuits is necessary to eliminate variation in response with changes in pulse-repetition frequency, and to reduce effects of noise in the phototube output.
- 2) Output signals from the digit phototubes during reading were not of sufficient amplitude to prevent marginal operation with the present amplifier circuits.

During the last two weeks of the quarter, studies of these difficulties have been undertaken. Direct-coupled amplification is necessary in the reference-marker phototube circuits; therefore, if the film is stopped on a reference marker, any noise which is present is fully amplified and may cause spurious sweeps of the beam in the cathode-ray tube. It was

pointed out by a representative of the Eastman-Kodak Company that noise suppression is best accomplished by providing "backlash" in a trigger circuit driven by the phototube signals. Such a trigger circuit is one which will flip to one position when the input signal has reached a certain amplitude but which will not flip back to its original position until the input signal amplitude has fallen somewhat below its first triggering value. When the difference between these two triggering voltages is made greater than the noise amplitude, the noise is effectively filtered out. A circuit of this type has been installed, but tests of its behavior when film is started and stopped have not yet been made.

Data taken previously on the response of the digit-phototube channels was invalidated during the last week by the discovery that the connection to the last accelerating anode of the cathode-ray tube was broken. Restoration of this connection increased the light output from the cathode-ray tube and hence increased the signal amplitudes from the digit phototubes so that marginal conditions no longer exist.

## 6. MATHEMATICS, CODING, AND APPLICATIONS

### 6.1 PROGRAMMING THE INPUT PROBLEM

#### 6.1.1 The Input Problem

Whenever some new task is to be performed by the Whirlwind computer, a coded program must be prepared to give the necessary data and the sequence of orders to be followed by the computer. This list of orders and numbers must then be put into the proper storage registers in the high-speed memory of the computer. When the coded program is first prepared, these orders and numbers are normally written using the two-letter code symbols for the various operations and ordinary decimal digits for the storage addresses and numbers, whereas for use by the computer they must be in a pure binary form. Furthermore, many coded programs will make use of standard automatic subroutines (cf. Section 6.1 of Summary Report 22) which will presumably be stored in some kind of library.

Consequently, orders and numbers of the coded program must be converted to binary form and the desired standard automatic subroutines must be selected from the library and adapted to the storage locations assigned to them (the location assigned to a subroutine will vary from one application to the next, and the address sections of certain of the orders in a subroutine must be changed in each application to adapt the subroutine to the assigned location). This conversion, selection, and adaptation could be performed by (1) a trained clerk, (2) special equipment, or (3) the computer itself. Of these three possibilities, the use of the computer is probably the cheapest and unquestionably the fastest and most easily obtained method.

From the point of view of the computer, this input problem is not essentially different from any other. A satisfactory coded program, which for concreteness can be called the initial program, is all that is needed to direct the computer to convert its own programs to pure binary form and to select and adapt its own subroutines. Of course, the subroutine library must be available on film in a film reader accessible to the machine, and the orders, numbers, indications of proper storage addresses, and requests for subroutines must all be written out in some standard form comprehensible to the machine, with letters and numbers translated into binary digital form. Readily-obtainable standard equipment, e. g. the Flexowriter equipment

mentioned in Sections 5.1 and 5.2, is available to translate letters and numbers into arbitrary sequences of binary digits which can then be unscrambled by the computer.

#### 6.1.2 Flexowriter Equipment

A Flexowriter perforator consists of a tape punch actuated by an electric typewriter with a standard typewriter keyboard. Whenever any key on the typewriter is depressed, one line of tape is punched resulting in a combination of holes and no holes in six different columns (a seventh column used for controlling film need not be considered). Thus, if holes are read as "ones" and no-holes as "zeros", each of the 50 different characters and machine operations appears on the tape as a unique six-digit binary number. For example, suppose one of the orders in a coded program is

cp 1027

This would be translated as follows:

c	011100	
p	101100	
space	001000	
1	100100	
0	101101	
2	100111	
7	001111	
carriage return	010000	

In this manner the orders and numbers, storage addresses, and subroutine request can be typewritten in a normal fashion and appear on tape as Flexowriter-coded binary numbers. The computer's job is then to translate the Flexowriter-coded information into pure binary form. Since the Flexowriter code, being a six-hole version of the ordinary five-hole teletype code, is quite arbitrary, the computer must be given a table of values to show what number or letter corresponds to each six-digit number. Whenever a request for a subroutine is received, the computer must select from the library film the proper subroutine, adapt the address sections of the orders, and store it in the proper registers.

#### 6.1.3 The Initial Program

The detailed mechanism of the initial program is too long and specialized to be presented here. The program has been written, however, and will be described in a forth-coming memorandum (M-1059: Detailed Coding of the Initial Program;

and see also E-356: Equipment and Techniques for Inserting Information into WWI).

#### 6.1.4 The Interim System

In Section 5.2 of this report is described the interim tape-to-computer transfer system to be used until film input can be operated reliably. This system provides the computer with the Flexowriter-coded characters and their complements. The only effect which this has on the initial program is that instead of getting two checked Flexowriter-coded characters from film with each reading, the computer will get one unchecked character from tape and must then make a second reading and check the character against its complement before proceeding.

It will also be necessary to provide some means for inserting pure binary information into the machine from tape, so that the initial program itself can be put into storage at the start of a new problem. The interim system provides only for reading six unchecked digits into six predetermined digit columns. Hence, the computer must not only check the character against its complement but also shift and accumulate these characters so that several of them can be combined into one 16-digit binary word which can then be stored in electrostatic storage. This reading-in of pure binary information (not Flexowriter-coded) will be done under the control of the computer using the 27 toggle-switch and five flip-flop registers of test storage, which can be manually set up.

#### 6.1.5 Modes of Pure Binary Tape Input

Putting pure binary information onto tape will be done in three different ways. One way, called the binary mode, involves typing the 16-digit binary numbers on a Flexowriter typewriter using the 0 and 1 keys. This would result in 16 lines on tape (plus their complements), with each line containing only one usable binary digit, the other five digits being redundant and hence meant to be discarded.

A second way, the sexadecimal mode, is to type 16-digit words on the Flexowriter by striking four characters using a special code so selected that four binary digits could be used from each character. For example, if the binary word 1001000110110110 were desired, the four letters w a q f would be used. The Flexowriter code for these letters is

w = 100110  
a = 000110  
q = 101110  
f = 011010

Notice that if the last two digits in each character are discarded and the four groups of four remaining digits are written out one after the other, the result is the desired 1001000110110110.

A third and most efficient way in which tape can be prepared is by putting six digits in one line and five in the next two lines thus recording a 16-digit word in three Flexowriter characters. This so-called 6-5-5 mode can be used only when the tape is being prepared by the computer, since the Flexowriter equipment, having only 50 keys, cannot be used to punch all of the 64 possible six-digit combinations which might be needed.

Programs are being written for use in test storage to read in any one of these three pure binary modes. These programs can then be used to put the initial program, or any other program already in pure binary form, into the computer to get it started. Later, of course, this filling of the computer will be accomplished by reading in directly from film using the ri operation, with no need for any input program in test storage.

## 6.2 CONVERSION DISPLAY

A new program recently written consists of a combination of two programs described previously. One of these, described in Section 6.24 of Summary Report 20, converts a binary number to decimal form and displays the results in a binary-coded fashion on the flip-flop storage indicator lights. The other, mentioned in Section 6.24 of Summary Report 22, causes the computer to display digits, letters, or other symbols on an oscilloscope, using point-by-point plotting. The new program combines these two into one 32-register program.

Any positive binary number within the capacity of the computer (less than one, in steps of  $2^{-15}$ ) is converted to a decimal fraction and displayed on the scope as a series of Arabic numerals. The conversion of a binary number to a five-digit decimal number requires about 0.4 millisecond, while the display of the result is performed in 19 milliseconds, so that the whole calculation can be repeated and retraced about 50 times a second.

The conversion is carried out by repeated multiplication of the number by the base to which it is to be converted—for instance, ten in the decimal case. That is, the number to be converted is multiplied by ten, the integer part of the result becomes the first digit of the converted number, the fractional remainder is again multiplied by ten, the integer part of this result becomes the second digit, the remainder is multiplied by ten, etc. (cf. pages 2 and 3 of E-293).

There are two pleasing features to this procedure. First, simply by letting the computation continue uninterrupted, one can increase the number of digits in the result to any desired length. Second, by multiplying repeatedly by some other number, rather than ten, one can convert the number in question to any desired base -- for instance to the base three, or five, or nine. With invented symbols for integers ten and eleven, readable conversion can be done to the base eleven or twelve as well.

A curious biproduct of this program is a fact which is of no real significance, but which may be intriguing to those interested in the theory of numbers. It shows the power of a digital computer in obtaining empirical data which could in some cases lead to important theorems in the theory of numbers. The fact referred to was uncovered when the number  $2^{-15}$  was converted to the base three by the conversion program.

It is known that any rational number expressed "decimally" to any integral base will lead eventually to a repeating expression. That is, disregarding the first few digits, or the first few million digits, if necessary, some one digit or some group (of any finite length) of digits will repeat and will then continue to repeat ad infinitum. The digit which repeats may of course be zero, in which case the expression is said to terminate. At first glance, one might well think that such a simple number as  $2^{-15}$  expressed to the base 3 would repeat every few digits. Upon investigation, however, it was found that the number  $2^{-15}$  written out to the base 3 gives rise to a number which repeats only every 8192 digits.

Further investigation, prompted simply by curiosity, lead to a result obtained empirically by repeated trials by the computer: whenever the number  $2^{-15}$  is written to any odd base, the expression obtained always repeats after  $2^n$  digits, where  $n$  is equal to 13 in half the cases, but never exceeds 13. (Bases divisible by two are not of much interest since it is easy to show that any even base leads to an expression which terminates after at most 15 digits). More generally, suppose that one expresses the base  $b$  in the form

$$b = k 2^m + 1 \quad \text{when } b \equiv 1 \pmod{4},$$

or

$$b = k 2^m - 1 \quad \text{when } b \equiv 3 \pmod{4},$$

where the expression  $(\text{mod } n)$  means that one is to consider only the remainder after dividing by  $n$  (e.g.,  $13 \equiv 1 \pmod{4}$  while  $19 \equiv 3 \pmod{4}$ ), and

where  $m$  and  $k$  are chosen to fit the equation for any given  $b$ , with  $k$  an odd integer. Then the number of digits in the repeating group, when  $2^{-15}$  is written to the base  $b$ , will be  $2^{15-m}$ . Thus:

Base	Number of Digits
$3 = 1 \cdot 2^2 - 1$	$2^{15-2} = 2^{13} = 8192$
$5 = 1 \cdot 2^2 + 1$	$2^{15-2} = 2^{13} = 8192$
$7 = 1 \cdot 2^3 - 1$	$2^{15-3} = 2^{12} = 4096$
$9 = 1 \cdot 2^3 + 1$	$2^{15-3} = 2^{12} = 4096$
$11 = 3 \cdot 2^2 - 1$	$2^{15-2} = 2^{13} = 8192$
$13 = 3 \cdot 2^2 + 1$	$2^{15-2} = 2^{13} = 8192$
$15 = 1 \cdot 2^4 - 1$	$2^{15-4} = 2^{11} = 2048$
$17 = 1 \cdot 2^4 + 1$	$2^{15-4} = 2^{11} = 2048$
$19 = 5 \cdot 2^2 - 1$	$2^{15-2} = 2^{13} = 8192$
...	...
$31 = 1 \cdot 2^5 - 1$	$2^{15-5} = 2^{10} = 1024$
...	...
$127 = 1 \cdot 2^7 - 1$	$2^{15-7} = 2^8 = 256$
...	...
$7169 = 7 \cdot 2^{10} + 1$	$2^{15-10} = 2^5 = 32$
etc.	etc.

The rule as stated was obtained empirically by examining all cases for  $b$  less than 514 and all cases for  $b = 2^p \pm 1$  for  $p$  less than 15. The rule does not hold for  $b = 2^{15} - 1 = 32767$ , although it does hold for  $b = 2^{15} + 1 = 32769$ . Establishing such a rule on theoretical grounds seems to require finding the least values of  $j$  which, for given values of  $k$  and  $m$ , will satisfy the congruences

$$(k 2^m + 1)^j \equiv 1 \pmod{2^{15}}$$

and

$$(k 2^m - 1)^j \equiv 1 \pmod{2^{15}}.$$

The empirical rule implies that  $j = 2^{15-m}$  is the required solution for both congruences, with  $k$  odd and  $1 < m < 15$ . A limited investigation has apparently corroborated this result.

## 7. ACADEMIC PROGRAM IN AUTOMATIC COMPUTATION AND NUMERICAL ANALYSIS

As an outgrowth of Project Whirlwind and the research in the MIT Center of Analysis, an expanded graduate-school academic program in Automatic Computation and Numerical Analysis is to be offered in 1950-51 by the MIT Electrical Engineering Department. Some of the subjects have been given previously and some are extensions of training formerly included as sections of other subjects.

The subjects are open to students of all academic departments according to the usual procedures of the graduate school. Information on prerequisites and admission to the graduate school can be found in the MIT 1950-51 catalog. The subjects specifically relating to Automatic Computation and Numerical Analysis might make up a full master's degree program if a student were to take all of them. In addition, many closely related subjects are taught in the graduate school.

The following subjects are to be offered in the fall term of 1950-51:

**Numerical Analysis, Subject 6.531,** taught by Professor Kopal: Systematic study of topics in numerical analysis selected to prepare the student for the task of converting the infinitesimal operations encountered in physics and engineering into equivalent algebraic forms which can be understood by digital computing machinery. Approximations of continuous functions by power polynomials, and interpolation in terms of ordinates as well as finite differences. Development of methods for numerical differentiation and integration, and their application to the solution of various types of ordinary differential equations with various types of boundary conditions.

**Seminar in Numerical Analysis, Subject 6.533,** taught by Professor Kopal: Opportunity for the individual study of advanced methods of numerical analysis and their application to machine computation, with emphasis on the application of such methods to problems arising in different fields of science and engineering. Conferences, with opportunity for detailed criticism; discussion of current literature.

**Introduction to Digital Computer Coding and Logic, Subject 6.535,** taught by Mr. W. Gordon Welchman: Coding treats the interpretation of arithmetical and logical sequences into digital computer instructions. Basic principles of digital

computer use are studies with examples selected from common engineering mathematics. The course includes logical analysis of a problem, flow diagrams, scale factor control, use of sub-programs and iterative sequences, and an introduction to real-time applications of digital computers.

**Control Systems Employing Two-Valued Elements, Subject 6.567,** taught by Mr. A.E. Ritchie of the Bell Telephone Laboratories: Principles and basic design methods are studied for interconnecting two-valued devices, primarily electromagnetic relays, to form systems for automatic control. Relay contact network design including algebra of logic is applied to counting, memory, translating and selecting, and the integration of functional components into systems applicable to the design of digital computers and automatic telephone switching systems.

The following subjects are to be offered in the spring term of 1950-51:

**Numerical Analysis, Subject 6.532,** taught by Professor Kopal: Eigenvalue problems in one and two variables; the accumulation of errors in extended computations. Approximate integration in terms of non-equidistant ordinates, and its use for algebraization of integral and integro-differential equations. Numerical treatment of partial differential equations, subject to different types of boundary conditions, by fixed procedures and by successive approximations. The use of characteristic coordinates for hyperbolic equations; relaxation methods for elliptic equations; convergence of the process.

**Laboratory in Numerical Analysis, Subject 6.534,** taught by Professor Kopal: Practical work in advanced topics of numerical analysis, selected mainly from problems discussed in 6.532; the choice of individual problems encouraged. The laboratory is open primarily to the students who are taking, or have taken, 6.532. Admission of other qualified students subject to approval of the instructor in charge.

**Machine Computation, Subject 6.536,** taught by Professor Caldwell: A study of computing machinery of the analogue type, with emphasis on the management of variables and on the engineering of computing elements and computing systems. Various types of computing elements are treated including mechanical, electromechanical, electrical and electronic devices. These are used in the combinations needed for obtaining solutions of ordinary differential equations, integral equations, simultaneous algebraic equations, algebraic polynomials

and for performing Fourier analysis and Fourier synthesis.

Electronic Computation Laboratory, Subject 6.538, taught by Mr. Frank Verzuh: The basic principles of digital computers are studied by experiments on the following components: synchrosopes and pulse-viewing equipment, pulse generators, bistable circuits, binary counters, decade counters, coincidence circuits, variable delay circuits, frequency dividers, electronic distributors, matrix switches, and magnetic recording equipment. The principles of electronic analogue computers are treated by a study of electronic integrators, electronic differentiators, data conversion equipment, data recording equipment and associated circuits. The work on the analogue equipment is handled in project assignments.

Following is a partial listing of related subjects available in the MIT Graduate School. Catalog numbers are given:

Electrical Engineering Department:

Statistical Communication Theory, 6.5C3  
 Transients in Linear Systems, 6.581, 6.582  
 Applications of Integral Equations in Electrical Engineering, 6.585  
 Servomechanisms, 6.605, 6.606  
 Principles of Pulse Circuits, 6.623  
 Modulation, Noise, and the Transmission of Information, 6.625  
 Electronic Circuit Theory, 6.633  
 Special Problems in Fire Control, 6.681

Mathematics Department:

Mathematical Theory of Statistics, M331, M332  
 Operations Research, M371, M372  
 Topics in the Theory of Numbers, M52  
 Mathematical Laboratory, M54  
 Partial Differential Equations, M591, M592  
 Mathematical Logic, M61  
 Integral Equations, M631  
 Foundations of Probability, M66  
 Characteristic Value Problems, M691, M692

Mechanical Engineering Department:

Relaxation Methods, 2.215  
 Flow of Compressible Fluids, 2.491, 2.492  
 Advanced Heat Transfer, 2.521  
 Control Problems in Mechanical Engineering, 2.783

Chemical Engineering Department:

Heat Transmission, 10.50

Naval Architecture and Marine Engineering Department:

Warship Form Design, 13.21  
 Ship Design, 13.47  
 Mechanical Vibration, 13.74

Aeronautical Engineering Department:

Guided Missiles, 16.18  
 Advanced Aeronautical Problems, 16.60

## 8. APPENDIX

### 8.1 REPORTS AND PUBLICATIONS

Project Whirlwind technical reports and memorandums are routinely distributed to only a restricted group who are known to have a particular interest in the Project. Other people who need information on specific phases of the work may obtain copies of individual reports by making requests to John C. Proctor, Servomechanisms Laboratory, 211 Massachusetts Avenue, Cambridge 39, Massachusetts.

The following reports and memorandums were among those issued during the second quarter of 1950.

No.	Title	No. of Pages	Date	Author
SR-21	Summary Report No. 21, Fourth Quarter, 1949	38		
SR-22	Summary Report No. 22, First Quarter, 1950	31		
R-175	Measurements on Electron Beams in Storage Tubes (SM Thesis; Summary in E-346)	59	3-15-50	J. McCusker
R-177	A Method of Test Checking an Electronic Digital Computer (SM Thesis; Abstract in E-344)	112	1-14-50	G. Cooper
R-178	Marginal Checking as an Aid to Computer Reliability	12	3-28-50	N.H. Taylor
R-181	Digital Computers in Control Systems	6	4-27-50	C.R. Wieser
R-182	New Developments in Pulsed Circuit Test Equipment	6	4-27-50	F.R. Rathbone
R-183	M.I.T. Electrostatic Storage Tube	10	4-27-50	S.H. Dodd H. Klemperer P. Youtz
R-184	Computer Experience in Extending Tube Life	6	4-27-50	E.S. Rich
R-185	Marginal Checking: Preventive Maintenance for Electronic Equipment	5	4-27-50	G.C. Sumner
R-186	An Investigation of the Possibilities for Improving Pentode-Gate-Tube Circuits (SM Thesis; Abstract in E-342)	71	4-26-50	C.A. Rowland
R-187	Digital Information Storage in Three Dimensions Using Magnetic Cores	12	5-16-50	J.W. Forrester
E-332	Forming End-of-Block Spaces on Film in Normal Operation	4	3-21-50	R.P. Mayer C.W. Adams
E-336	Secondary Emission from Beryllium Surfaces at Low Incident Electron Energies (Abstract of SM Thesis)	1	4- 3-50	H.E. Rowe
E-337	Accelerated Life Test for Cathode Interface in Receiving Type Tubes	3	4- 3-50	E.S. Rich
E-338	Test Results of L9B and F8B Productions of 7AD7 Tubes	1	4-11-50	H.B. Frost
E-340	Current Density Distribution and Spot Diameter in Cathode Ray Beam	10	4-17-50	H.E. Rowe A. Tanguay
E-343	Computer Input-Tape Preparation	87	5-25-50	F.A. Foss

No.		No. of Pages	Date	Author
E-348	Winding Tungsten Springs - SA-33325	3	6- 9-50	I. Paulsen
E-350	Construction of a Silver Evaporation Target Assembly	5	6- 6-50	J. Palermo
E-351	Winding Tungsten Heaters - SB-40170	2	6-12-50	I. Paulsen
E-352	Compensation of Deflection Defocusing in Storage Tubes	5	6-15-50	H. Klemperer
M-1022	Systems Planning	3	4-11-50	N.H. Taylor
M-1036	The Differential Analyzer Approach in Digital Computers	12	5- 3-50	C.W. Adams
M-1038	Checking the Holding Ability of Flip-Flops	5	5- 9-50	J.M. Salzer
M-1044	History of Development of Storage Assembly for 6" Storage Tube	4	5-19-50	R. Shaw
M-1045	Data on Electron Gun Currents in M.I.T. Storage Tubes	4	5-18-50	M. Florencourt
M-1056	Development of Type SR-1407 Vacuum Tubes: Tests on Lots D-2 and C-9674	4	6-20-50	E.S. Rich

## 8.2 PROFESSIONAL SOCIETY PAPERS

Members of the Project staff presented a symposium entitled "Contributions to Electrical Engineering from Digital Computer Research" at the North Eastern District meeting of the AIEE on April 27. The session was under the chairmanship of Jay W. Forrester. The following papers were delivered:

C.R. Wieser	Digital Computers in Control Systems
S.H. Dodd, H. Klemperer, and P. Youtz (delivered by S.H. Dodd)	The MIT Electrostatic Storage Tube
E.S. Rich	Computer Experience in Extending Tube Life
G.C. Sumner	Marginal Checking as an Aid to Computer Reliability
R.R. Rathbone	New Developments in Pulsed-Circuit Test Equipment

All of these papers have been issued as R-series reports (see 8.1 above).

## 8.3 VISITORS

During the past quarter the Laboratory has had among its visitors the following:

Rear Adm. T. A. Solberg, Chief of Naval Research; Cmdr. W. H. Groverman of the Undersea Warfare Branch of ONR; Dr. E. R. Piore of the Physical Sciences Division of ONR; and Capt. A. L. Pleasants and Dr. C. F. Muckenhoupt of the Boston Branch of ONR.

Dr. R. D. O'Neal and Mr. Harry H. Goode of the Aeronautical Research Center of the University of Michigan.

Mr. S. C. Hight and Mr. J. O. McNally of Bell Telephone Laboratories, who were especially interested in our experience with vacuum-tube life.

Cdr. J. F. Quinn and Mr. Arnold Shostak of the Armament Branch of ONR.

Dr. Jan Rajchman and Mr. Charles Young of RCA.

Mr. B. W. Pollard, in charge of electronic computer work at Ferranti Electronics, Ltd.

Dr. T. T. Goldsmith of Du Mont Laboratories, particularly interested in storage tubes.

Dr. Walter E. Mutter, Dr. Richard K. Steinberg, Dr. Werner Buchholz, and Dr. Donald R. Young, all of International Business Machines Corporation, and Dr. Robert C. Fletcher of Bell Telephone Laboratories, who discussed cathode life in vacuum tubes.

Mr. A. V. Dasbury and Mr. J. C. O'Brien of General Railway Signal Company, who may attempt some filter calculations on Whirlwind.

Mr. David Arenberg of the U. S. Naval Air Development Center, interested in quartz delay lines.

Mr. Bjorn Lundvall of the L. M. Ericsson Company (Swedish telephones), who told us of interesting reliability achieved in certain vacuum tubes by special processing.

Mr. D. T. Ferrier of Hazeltine Electronics, to discuss pulse circuits.

Prof. A. G. Emslie of Williams College, who is studying high-speed switch methods for electronic computers.

Mr. D. H. Gridley and Mr. B. L. Sarahan of the Naval Research Laboratory.

Members of the M.I.T. class in machine computation.

Dr. Gertrude Blanch of the National Bureau of Standards.

Mr. J. J. Connelly of the Teleregister Corporation, to discuss marginal checking.

Mr. G. W. Gilman of Bell Telephone Laboratories.

Dr. F. J. Weyl of the Mathematics Branch of ONR, to discuss mathematical applications of Whirlwind.

Mr. R. C. Coile of the Operations Evaluation Group.

Mr. O. D. Seeley, Mr. V. M. Horn, and Mr. John Trevor of the Metropolitan Life Insurance Company, who are surveying work in high-speed computation.

Sir Charles Wright of the British Joint Services Mission, Mr. W. R. Cook of the Admiralty Research, and Mr. S. W. Coppock of the British Joint Services Mission.

Mr. A. V. Cohee of the U. S. Naval Ordnance Plant at Indianapolis.

Mr. A. C. Ratz and Mr. Joseph Katz of the University of Toronto's computer project.

Dr. Glen D. Camp and Mr. John A. Kessler of the Operations Evaluation Group.

A group from General Radio Company for a tour of the laboratory.

Dr. V. K. Zworykin of RCA.

Mr. Albert V. Baez of Cornell Aeronautical Laboratory.

Dr. J. Rothstein of Evans Signal Laboratory, interested in accelerated life testing of vacuum tubes.

Mr. C. H. Warsaw of ONR.

Mr. Harry Davis, Chief of Navigation Division, and Mr. Irving Gabelman of Watson Laboratories.

Col. Gilbert Hayden, Maj. G. H. Duncan, and Capt. R. L. Tatum of Headquarters, Air Materiel Command.

Mr. D. A. Quarles of Bell Telephone Laboratories.

Mr. James H. Muncy of the Naval Air Development Center to discuss storage problems generally.

Mr. L. H. Cherry of the Naval Air Missile Test Center, with Mr. W. N. Short and Mr. C. F. West of Raytheon.

Mr. H. W. Bacheller and Mr. A. W. Andrews of the Bureau of Ships.