

Error Correction in Orbital Flight
Alexander G. ... June 17, 1950

TROL

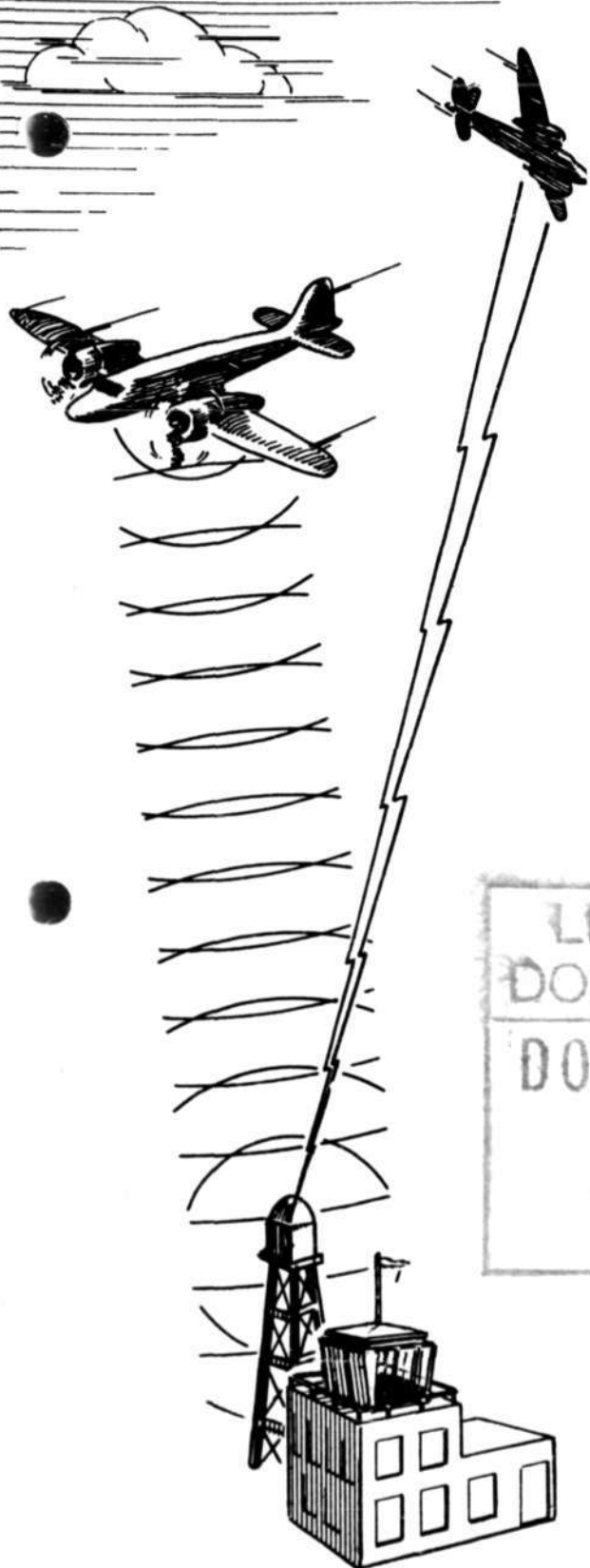

REPORT R-189

ERROR CORRECTION IN ORBITAL FLIGHT

JUNE 13, 1950

LIN. LAB. DIV. 6
DOCUMENT ROOM
DO NOT REMOVE
FROM
THIS ROOM

Copy 14

Submitted to the
WATSON LABORATORIES
AIR MATERIEL COMMAND
Under Contract AF 28(099)-45

**SERVOMECHANISMS LABORATORY
MASSACHUSETTS INSTITUTE OF TECHNOLOGY**

APPROVED FOR PUBLIC RELEASE. CASE 06-1104.

AIR TRAFFIC CONTROL PROJECT

Report R-189

ERROR CORRECTION IN ORBITAL FLIGHT

Submitted to
WATSON LABORATORIES,
Air Materiel Command
AF28(099)-45

Report by
Alexander Orden
SERVOMECHANISMS LABORATORY
MASSACHUSETTS INSTITUTE OF TECHNOLOGY
Cambridge 39, Massachusetts
Project DIC 6673

June 13, 1950
(Thesis Date: May 11, 1950)

Report R-189

FOREWORD

Because it presents information of possibly lasting value, this doctor's thesis report, which has had only very limited distribution, is being issued as an Air Traffic Control Project R-series report.

The work on this thesis arose as part of a long-range investigation of the application of electronic digital computers in air traffic control. As background to the investigation it was necessary to survey possible methods of obtaining high-precision aircraft flight guidance in the neighborhood of an airport. The analysis of a proposed method of guidance, which appeared promising in several ways to be discussed later, was selected as the subject for the thesis.

My thanks to Professor Philip Franklin for sound advice in the planning and execution of this thesis. I am grateful also to W. G. Welchman and C. R. Wieser of the Project Whirlwind Air Traffic Control group for advice in formulating the thesis problem and in reviewing the work as it progressed.

TABLE OF CONTENTS

	<u>Page</u>
Foreword.....	ii
Abstract.....	v
I. Summary.....	1
A. <u>Statement of the Problem</u>	1
B. <u>Outline of Procedure</u>	3
C. <u>Summary of Results</u>	4
II. Introduction.....	8
A. <u>Air Navigation and Traffic Control</u>	8
B. <u>Automatic Digital Computers</u>	11
C. <u>Airport Approach Control</u>	12
D. <u>Precision Guidance of Aircraft</u>	13
E. <u>Formulation of the Thesis Problem</u>	15
III. Geometric and Elementary Dynamic Considerations.....	16
Section 1. <u>Coordinate System and Notations</u>	16
Section 2. <u>Basic Equations and Limiting Factors</u>	19
Section 3. <u>Functions of Azimuth Progress Control</u>	23
Section 4. <u>Reference Curves</u>	34
Section 5. <u>Geometrical Aspects of Integration of Azimuth Control into Complete Approach Plans</u>	39
Section 6. <u>Discussion of Limiting Factors</u>	51
Section 7. <u>Notes on Reference Functions (Supplement to Section 4)</u>	54
Section 8. <u>Equations for Section 5g</u>	60
IV. <u>Stabilization</u>	62
Section 9. <u>Linear Approximation Procedures</u>	62
Section 10. <u>Dynamic System Assumptions</u>	67
Section 11. <u>Basic Control System</u>	70
Section 12. <u>Alternative Stabilization Systems</u>	77
Section 13. <u>Further Consideration of a Control System Using Azimuth and Heading Feedback</u>	87
V. <u>Stabilized Flight Paths</u>	94
Section 14. <u>Correction of Initial Error at Constant Speed</u>	94
Section 15. <u>Stabilization during Speed Reduction</u>	98
Section 16. <u>Simplification of the Analytic Procedure</u>	99
Section 17. <u>Effect of Non-Linearity</u>	104
Section 18. <u>Supplements to Sections 14, 15, and 16</u>	109

VI. Effect of Wind.....	114
Section 19. <u>Circular Paths, without Azimuth Control</u>	114
Section 20. <u>Azimuth Stabilization</u>	118
Section 21. <u>Heading Reference Adjustment</u>	122
Section 22. <u>Appendix</u>	127
 Bibliography.....	 130
Biographical Note.....	132

Report R-189

ABSTRACT

As part of an investigation of possible future forms of air traffic control, an analysis is made of orbital motion around an Omni-Range DME station. It is assumed that each aircraft would be assigned an azimuth-vs-time schedule, and that maintenance of the schedule would be by path variation: reduction of radius when behind schedule and increase of radius when ahead of schedule. In order to estimate the precision of the proposed type of orbital guidance an autopilot control system is formulated. Aircraft motion is assumed to be governed by the equations of a "coordinated turn". Feedback of azimuth and heading and their first derivatives are shown to be needed for stabilization. Linear approximation procedures are shown to be fairly satisfactory for estimating the control system behavior.

For appraisal of azimuth deviation characteristics, computations are made using reasonable assumptions for various parameters. Results are: (1) ~~Assuming no wind and constant aircraft speed,~~ an initial error in azimuth of up to 20° could be reduced about 30% in 1 minute and 80% in 2 minutes. (2) Assuming 1 mile per minute per minute deceleration, an aircraft on schedule at the beginning of deceleration would be 10° behind schedule after 2 minutes. (3) Maximum azimuth errors caused by wind are of the order of $0.1 \frac{w}{V}$ where w = wind speed and V = aircraft speed. Deviations due to wind might be reduced by means of heading compensation.

I. Summary

A. Statement of the Problem

The type of aircraft guidance to be analyzed will be called "azimuth progress control". In this proposed form of control aircraft may be visualized as flying circumferentially on successive spokes of a rotating wheel whose hub is at or near an airport. The normal orbital radius of each aircraft is proportional to its speed. An aircraft corrects deviations from its proper azimuth by moving outward if it is ahead of schedule and inward if it is behind schedule, thus changing its azimuth progress rate until the error is corrected.

Systems of scheduling are frequently described by the terms "fixed block" or "moving block" control. An analogous term for azimuth progress control is "moving line" control. The meaning is clear from considering the motion in terms of the spokes of a wheel.

Azimuth progress control in the form studied in the thesis will be defined as orbital guidance of aircraft relative to given azimuth schedules, with error correction by variation of flight path rather than by variation of speed. The idea of

Report R-189

- 2 -

correction by path variation implies that the stabilization system in the aircraft must take over the directional control of aircraft motion but not the speed control. Since scheduling is ordinarily thought of in terms of speed control, one purpose of the thesis is to describe and analyze a supplementary or alternative method, namely one in which error correction is achieved by path variation.

The main problem of the thesis is to evaluate the error correction characteristics to be expected under azimuth progress control. An analysis of error correction is made under the conditions: (1) No wind, aircraft initially off schedule, (2) No wind, aircraft changes speed, (3) Effect of steady wind. Subsidiary studies, which serve as a foundation for work on the main problem and are also independently important in overall evaluation of the idea of guidance by azimuth progress control, are:

- (1) Geometric considerations in guidance by azimuth schedules.
- (2) Study of control systems for azimuth progress stabilization.

B. Outline of Procedure

The main line of procedure is as follows:

The dynamics of motion of an aircraft under azimuth progress control is given the simplifying description that it consists of three elements:

- (1) A controller (pilot or auto-pilot)
- (2) The aircraft
- (3) The instruments which provide feedback and schedule information.

Equations for description of the first two elements are introduced on the basis of two assumptions generally considered suitable for analysis of flight control:

- (1) Lag in the action of the control mechanisms inside the aircraft is negligible in comparison with that of the aircraft mass.
- (2) The aircraft moves in a coordinated turn (no sideslip).

The dynamic equations set up on the basis of the above assumptions are linearized in order to determine stability requirements. It is shown that the system can be stabilized by feedback of azimuth and heading and their derivatives, in the form of deviations from references which are based on the desired azimuth schedule.

The analysis of error correction characteristics then follows, using the linear approximation already introduced for

study of stabilization. The stabilization equations are for constant speed, and no wind. Change of speed and introduction of a steady wind are handled as linear perturbations. The errors introduced by linear approximation are examined and shown to be reasonably small over the range of variables over which the behavior of the system is of interest.

C. Summary of Results

In order to express results in the most tangible form, namely, as numerical estimates, values have been assumed for various parameters such as scheduled azimuth rate, aircraft speed, wind magnitude, and others. The equations and description of procedure in the text can be used to obtain results under other parameter assumptions or for study of the effect of varying certain parameters.

A preliminary consideration is that azimuth progress control calls for a lower scheduled rate of turn in orbital flight than might otherwise be used. (This is perhaps a disadvantage of azimuth progress control in comparison with other forms of guidance, but need not be considered in that light until a complete comparison of alternative systems is available.) The reason for the limitation is simply that if the maximum allowable rate of turn were used as the scheduled rate, there would be no leeway for error correction when an aircraft is behind schedule. A rate of 1 radian/min., or approximately 1 degree/second is assumed in the analysis.

The results on error correction are:

- (1) No wind, constant speed -- Initial errors on entering an azimuth control sector of up to about 20 degrees would be reduced about 30% in 1 minute and 80% in 2 minutes.
- (2) Deceleration from 4 miles/min. to 2 miles/min. at a rate of 1 mile/min.², no wind (this condition is intended to represent deceleration from cruising speed to final approach speed while flying in an azimuth control sector). -- An aircraft exactly on schedule at the start of deceleration would be 10° behind schedule at the end of deceleration.
- (3) Let the ratio of wind speed to aircraft airspeed be $\frac{w}{v}$ -- The maximum azimuth error due to wind is $60 \frac{w}{v}$ degrees, e.g. 6° at $\frac{w}{v} = \frac{1}{10}$.
- (4) Compensation for wind -- Assuming that wind measurements can be obtained, the azimuth errors due to wind can be reduced, at the expense of complicating the control system. A heading adjustment instruction which is a sinusoidal function of wind magnitude and direction is given in the text. Under the wind compensating heading instruction, azimuth errors due to the measured component of wind would become negligible. The results of (3) above would then apply for a wind vector, w_1 , which is the difference between actual wind and the measured value for which compensation has been introduced.

The geometric aspects of analysis of azimuth progress control given in the thesis may be summarized as follows:

(1) Azimuth progress control is described as guidance relative to azimuth and heading "reference functions". The azimuth "reference function" is the aircraft schedule, but it is shown that a heading "reference function" plays an equally important role in the guidance of the aircraft. Azimuth and heading reference functions are given for several types of curved path other than simple orbital circles, e.g. equiangular spirals.

(2) The geometric limits on error correction are examined and the results serve as a check on the dynamic analysis.

(3) The organization of systems of paths and schedules for approach to airports is a complex problem for which various solutions are being considered. In order to contribute to basic analysis of the problem, the thesis subdivides the nature of guidance under azimuth progress control into several distinct attributes, such that any one or a combination might be the prime factor which would make use of azimuth progress control advantageous. The elementary attributes are:

- (a) As a relatively simple systematic form of aircraft separation.
- (b) As a means of maintaining precision schedules on curved paths.
- (c) As a means of introducing controlled path variation to make flight progress corrections.
- (d) As a scheduling system in which speed control can be left to the discretion of the pilot.

The procedural problem of formulating control system equations for study of aircraft motion under azimuth progress control led to two auxiliary results:

(1) Azimuth progress control should not be considered as a system of control which calls for a complete set of additional equipment in an aircraft. It would instead call for addition of relatively simple auxiliary devices to standard auto-pilot equipment.

(2) The instrument measurements available in an aircraft might be used in several different combinations as feedback for azimuth progress control. Significant differences between the alternative methods are noted, but are not studied in detail.

II. Introduction

A. Air Navigation and Traffic Control

During the past few years the air transportation industry has reached the stage where traffic control is recognized as one of its major problems. It is not a new problem, but rather one which must now be given greatly increased attention. Over a period of 20 years the Civil Aeronautics Administration has built up a complex network of facilities for air navigation and traffic control. Like every phase of aeronautics these facilities have constantly been undergoing expansion and introduction of new developments.

Investigations of present and proposed future systems of traffic control must deal with a variety of factors such as flight speeds, landing speeds, flight altitudes, weather, air navigation facilities, airport design, instrument flight procedures, economic factors, etc. There are too many such considerations to discuss here. It will merely be noted that this thesis is part of a project on the potentialities of electronic digital computers in air traffic control and that the above factors are being studied. Assumptions used in the thesis are in general drawn from these studies.

To provide perspective on the air traffic control problem, three broad stages in the development of air navigation facilities should be noted:

(1) The initial basic system of air navigation in the U. S., which is still in existence but will soon be replaced, consists of a system of "Radio Ranges". These are radio beams* which provide fixed air routes. When the pilot cannot see the ground, position along a route is obtained when the aircraft passes certain "fixes", such as intersection of routes or other radio markers. Between "fixes" position can only be estimated by extrapolation from a previous "fix". Traffic control specifies minimum separations in bad weather. During the early stages of growth of air transportation, when the amount of traffic was small, traffic control could be fitted to this navigation system, but the system is now obsolescent.

(2) An important advance in air transportation came with the introduction of the "Instrument Landing System" (ILS). This facility permitted a great increase of air traffic in poor weather. As a result the traffic control problem became more difficult both along the air routes and in airport approach zones. In particular, the "stacking" of aircraft waiting to land became a serious problem, -- at major terminals aircraft have sometimes had to circle for an hour before reaching their turn to land.

* The "beams" referred to in describing Radio Range and Omni-Range are not actually focussed beams. They are direction indications which involve phase and intensity relations of radiation patterns.

(3) Present and future traffic requirements dictate expansion of navigation facilities. Radio Ranges, which provide only a limited number of routes, are being replaced by the "Omni-directional Range" system. The latter will consist of rotating radio beams, located at airports and en route points, which will provide aircraft with their azimuth relative to ground stations. "Omni-Range" is an extension of the Radio Range system in the sense that it will provide guidance for approach to an airport or en route point along any azimuth line rather than only along fixed routes.

Radio "Distance Measuring Equipment" (DME) is under development. Each aircraft equipped with DME will be able to measure its radial distance from Omni-Range stations. The combination of Omni-Range and DME will provide aircraft with complete position information in polar coordinates. (Omni-Range alone can in principle also provide full position information by use of azimuth measurements relative to two stations; however, this procedure would be inferior to use of DME).

Devices for automatic conversion from polar to Cartesian coordinates ("Course Computers") are being developed for use in conjunction with Omni-Range and DME. The conversion will provide parallel en-route courses.

B. Automatic Digital Computers

In the present air traffic control system all data are handled by human operators. The controllers work with en route position fixes which are obtained about once every 15 minutes from each aircraft. It appears that they would not be able to handle more frequent position reports, nor cope with much more complex traffic. Introduction of Omni-Range and DME navigation in place of Radio Ranges means that:

- (1) There will be greater flexibility in routing.
- (2) Position data will be constantly available.

It is doubtful whether human controllers will be able to take full advantage of these developments.

The potentiality of application of automatic digital computers lies in the need for rapid handling of a large amount of information. When computers become available they should be able to take over at least the routine parts of the work now done by human operators.

A concept which underlies much of the work of the M. I. T. Air Traffic Control Project is that in investigating the use of automatic digital computers in air traffic control a computer should be considered primarily as a control device rather than simply as a high speed bookkeeping unit. The main reasons it is important to take this point of view are:

- (1) Computers are intended to operate in "real time", i.e. compute rapidly enough to play a dynamic role in the operation of the control system,

(2) Computers can incorporate "conditional programming" (automatic selection of alternative control instructions on the basis of data and computations).

The general concept of digital computers as elements of control systems has been fully described in the fourth quarterly progress report of the Project.

Assuming that automatic computers will be incorporated in future traffic control systems, basic investigation is needed on procedures for determination of flight routes and schedules. Present procedures based on Radio Range routes and infrequent position reports offer little guidance for future developments. A general investigation of the problem was started by the Project. The thesis is part of that investigation.

Actually, the functions of a digital computer will not enter directly in the thesis. The reason for this is that any proposed form of scheduling, in which aircraft receive frequent or continuous control instructions, must first be studied as a problem in the dynamics of aircraft guidance. The thesis is concerned primarily with this phase of the problem.

C. Airport Approach Control

The work of the Project has been focussed mainly on forms of traffic control for airport approach. This aspect of traffic control, even more than that of en route control, calls for high speed data handling and computation.

Report R-189

The study of airport approach traffic control has thus far dealt with two main problems:

- (1) Formulation of flight patterns
- (2) Determination of maximum safe traffic

The second problem has taken the form of studies on whether control systems can ultimately be developed which would permit successive landings in all weather at a rate of one aircraft every half-minute (on a single runway). This goal requires the development of precision guidance systems which can bring aircraft to within about ± 5 seconds of a specified schedule in the final stage of approach.

The ultimate criterion for air traffic control is safety. Regardless of traffic levels, maximum safety in the approach zone would be attained by precision guidance in time and position.

D. Precision Guidance of Aircraft

The term "guidance" here will denote control of an aircraft according to assigned flight instructions. The instructions may be of various types such as: a given flight path relative to the ground without regard to altitude or rate of progress; a time schedule along a fixed path; a fixed rate of turn; an azimuth schedule, etc. It appears to be feasible to introduce relatively high precision guidance of aircraft in the airport approach zone. ILS landing approach is one type of precision guidance which is in practical use, and may be considered to be

a first step in the evolution of future approach systems. (ILS itself may, however, be superseded by other developments.)

The problem of this thesis and related studies on the Project is to evaluate procedures for path and schedule guidance. For simplicity altitude may be assumed to be constant in these studies. The types of guidance may then be classed as:

- (1) Complete guidance - Use of fixed paths with schedules maintained by control of aircraft speed.
- (2) Schedule control by path variation (with or without speed control) - Azimuth progress control falls in this classification -- a given azimuth schedule is to be maintained by variation of radius. Other forms of scheduling using path variation have been examined by the Project, but have not been studied as carefully as Azimuth Progress Control.

The precision of path or schedule following depends of course on the precision of navigational measurements. The maximum error of Omni-Range in its present stage of development is about 3 degrees. LME has apparently not yet had thorough service tests, but it appears that present equipment will have a maximum error of about one-half mile. Equipment of greater accuracy is under development. Eventually azimuth accuracy to 0.1 degree and distance to within 200 feet may be available in the approach zone. (These accuracies would be unnecessary en route.)

E. Formulation of the Thesis Problem

The idea of azimuth progress control was proposed by W. G. Welchman. It was the basis for an airport approach plan which we called the "Spiral Staircase". Under this plan each aircraft approaching for a landing would enter a circulating flight sector at an assigned azimuth, then proceed at a constant rate of azimuth progress while it reduced speed and altitude. Separation between aircraft would be provided by the azimuth "spoke" pattern. The idea is described more fully in the third quarterly progress report of the Project.

The "Spiral Staircase" plan has been studied as a traffic control system by W. G. Welchman and D. R. Israel. This thesis relates to their work by going into the question of the dynamic characteristics of motion of an aircraft under azimuth progress control. Rather than restrict the analysis to specific assumptions of the "Spiral Staircase" traffic system study, the thesis investigates the general geometric and dynamic characteristics of azimuth progress control as a method of aircraft guidance. The results are intended to provide a basis for evaluation of the advantages and disadvantages of azimuth progress control as a means of schedule stabilization on any part of an approach system which calls for curved flight paths, for example on a "procedure turn" preceding the final glide path.

III. Geometric and Elementary Dynamic Considerations

This chapter describes geometric characteristics of azimuth progress control under the condition of no wind. The purpose is twofold:

- (1) To present geometric and dynamic relations which will enter into subsequent analysis of control system stabilization.
- (2) To show how azimuth progress control might operate in airport approach systems. The aim will be to isolate and discuss basic elements of azimuth control as a guidance technique, rather than to formulate an approach plan as a whole.

Section 1. Coordinate Systems and Notations

Position of an aircraft will be measured in polar coordinates r, θ relative to a fixed ground station, O , as in figure 1. The point, O , will be considered to be the location of an Omni-Range, D. N. E. station which provides radio facilities for measurement of r, θ by the aircraft. However, it is also possible to consider, O , as any fixed ground point to which r, θ are referred by coordinate transformation calculations. The calculations might be carried out in air-borne equipment, or in a ground station computer, depending on the navigation system.

Aircraft motion will be treated entirely as though it were level flight. In practice, aircraft in the approach zone

Throughout this chapter it will be assumed that there is no wind, and that the aircraft motion is without sideslip. \bar{V} then corresponds with the direction of the aircraft axis, and we may refer to ψ as the aircraft heading.

The pilot of an aircraft thinks in terms of polar coordinates with center P, and reference line along the axis of the aircraft. In his system $(\rho + 90^\circ)$ is the azimuth of the ground station, O. For analytical purposes it is more convenient to use ρ than $\rho + 90^\circ$ and to refer entirely to the ground coordinate system as in Figure 1 rather than introduce aircraft coordinates as well. ρ will be termed the "relative heading".

Figure 1 shows that:

$$\rho = \theta + \psi \quad \dots(1.1)$$

Other symbols used in this chapter are:

ϕ = bank angle, measured positive in the right hand screw sense about the aircraft longitudinal axis. $\phi = 0$ in level flight.

t = time

g = gravity constant

W = aircraft weight

v, V for true air speed. The difference between flight at constant speed and flight during change of speed is important in the analysis. To emphasize the distinction, the capital letter, V, will always be used for constant speed and the small letter, v, for varying speed.

The following remark on units applies for the entire report: In analysis and computation it has been convenient to use radian measure for angles, and the description of analytic procedures in later sections will refer to radians. However, for better visualization, final results will generally be converted to degrees. Time will generally be in minutes and distance in miles. It should be noted that an azimuth rate of one radian per minute is nearly the same as one degree per second.

Section 2. Basic Equations and Limiting Factors

It will be assumed that the rudder and ailerons of the aircraft are always controlled in the correct relation to provide "coordinated turns". The lateral equation of motion of the center of gravity of the aircraft for flight at constant altitude is then:

$$\frac{W\dot{\phi}}{g} = W \tan \phi \quad \dots(2.1)$$

The linear approximation to (2.1) with $\tan \phi$ replaced by ϕ is fairly satisfactory up to $\phi = 30^\circ$ and will generally be used:

$$\frac{W\dot{\phi}}{g} = \phi \quad \dots(2.2)$$

We will not be concerned with thrust and drag forces and will therefore write the other equation of motion of the center of gravity of the aircraft as:

$$\dot{r}^2 + r^2 \dot{\theta}^2 = v^2 \quad \dots(2.3)$$

In this chapter in dealing with geometrical aspects of azimuth progress control, (2.3) and equations which follow from it will be the primary considerations. The lateral force equation, (2.1) will not have a major role until the analysis of stabilization in subsequent chapters.

Azimuth progress control is characterized by an azimuth schedule $\theta(t)$, the radius r being left free to vary with the speed of the aircraft. With $\theta(t)$ specified, equation (2.3) may be solved for r for any aircraft speed. However the nature of the system emerges more clearly by supplanting (2.3) as follows: (assume constant speed)

$$\begin{aligned} \dot{r} &= v \sin \beta \\ r\dot{\theta} &= v \cos \beta \end{aligned} \quad \dots(2.4)$$

(2.4) is equivalent to (2.3). Now eliminate r and v by writing:

$$r = \frac{v \cos \beta}{\dot{\theta}}$$

differentiate,

$$\dot{r} = - \frac{v \sin \beta}{\dot{\theta}} \ddot{\theta} - \frac{v \cos \beta}{\dot{\theta}^2} \ddot{\theta}$$

substitute $\dot{r} = v \sin \beta$,

$$\sin \beta = - \frac{\sin \beta}{\dot{\theta}} \ddot{\theta} - \frac{\cos \beta}{\dot{\theta}^2} \ddot{\theta}$$

$$\ddot{\theta} + (\dot{\theta}^2 + \dot{\theta} \dot{\beta}) \tan \beta = 0 \quad \dots(2.5)$$

Equation (2.5) is equivalent to equation (2.3). Although more complex, it is more significant for azimuth control since

linear dimensions have been eliminated. Consider an azimuth schedule $\theta(t)$, and solve (2.5) for the associated "relative heading" schedule, $\beta(t)$. The pair of functions, $\theta(t)$ and $\beta(t)$ then represent a family of paths with parameter V . For any specific V , we have by (2.4), $r = V \frac{\cos \beta}{\dot{\theta}}$. Thus r is proportional to V , and the azimuth schedule represents a family of radially proportional curves. An aircraft following a $\{\theta(t), \beta(t)\}$ schedule at speed V moves along one of these curves, and when its speed is changed it must shuttle across the family until the speed is stabilized at a new value of V . In the simplest case the family consists of concentric circles, and when speed is reduced the paths spiral inward. Angular schedules $\theta(t)$ and $\beta(t)$ which determine several types of curves of interest will be given in Section 4.

A family of radially similar paths corresponding to an azimuth schedule $\theta(t)$ and the associated heading schedule, will be termed reference paths. The problem of stabilization by azimuth progress control will involve finding control systems which will cause an aircraft travelling at speed V to stabilize onto the corresponding reference path.

Equation (2.5) is not as complex as it appears at first glance. If $\theta(t)$ is a given desired azimuth schedule, it is a first order differential equation in β . It will also be useful to assume a β schedule, e.g., for an equiangular spiral, and use (2.5) to determine the azimuth schedule required. If β is given as a function of t , (2.5) is a first order differential equation in $\dot{\theta}$.

Before proceeding to possible functions of azimuth control in airport approach systems and to formulation of reference paths of interest, factors are listed here which will limit the control system behavior in various ways. A discussion of these points will be given in an appendix -- Section 6.

- (a) Larger schedule corrections can be made by an azimuth control system when the aircraft is ahead of schedule than when it is behind schedule.
 - (b) A heading, reference schedule and heading error measurement will be needed for stabilization, along with azimuth schedule and azimuth error measurement.
 - (c) Permissible bank angle and rate of roll will be limited to about 30° , and about $5^\circ/\text{second}$ respectively (for commercial aviation).
 - (d) Azimuth progress rate should be based on a bank angle of about 15° in order to provide leeway for stabilization.
 - (e) The accuracy of time schedule control is related to the angular progress rate in the system: the higher the angular rate, the better the time accuracy.
 - (f) The angle β of the reference paths will be limited to $\pm 30^\circ$, since at larger values of β the characteristic features of azimuth progress control disappear.
-

Section 3. Functions of Azimuth Progress Control

The study of aircraft guidance and scheduling, of which this report is a part, has as one of its principal aims the determination of practical systems for guiding aircraft through an approach zone to a landing. It appears that the approach zone should be considered as a circle of at least 30 miles radius about the airport, and possibly a good deal larger. Guidance systems are being analyzed from two complementary points of view: (1) Formulation of integrated plans of guidance for the entire approach, and (2) Evaluation of guidance techniques which can be used to effectuate part or all of the integrated plan. This report is a study of one proposed guidance technique and is presented primarily as an aid to others in the group who are studying approach plans as a whole.

It is clear that azimuth progress control cannot be the only form of guidance in an approach zone since the final approach to a runway must be a fixed path. The point of view taken here will be to present particular guidance functions for which azimuth progress control may provide one possible solution, leaving the comparison with other guidance techniques, and formulation of complete approach plans for other studies. This section will present basic guidance functions, while considerations with regard to integrating these functions into complete systems will be discussed in Section 5.

Incidentally, although the concept of azimuth progress control is being examined here in isolation from other types of

guidance, it should not be considered to be a technique whose procedure and equipment will be distinct from the other parts of a guidance system. A complete guidance system will undoubtedly be considered as a unit designed for several interrelated types of operation with overlapping uses of instruments and equipment. This is already the case in present day aircraft, in which an auto-pilot can be used for pilot relief en route and for glide path stabilization on I. L. S. approaches. In this regard, Section /3 will present a formulation of azimuth progress control in which the stabilization system will be considered as an auxiliary to an auto-pilot.

It will be assumed here that an over-all approach system will consist of a procedure in which each aircraft will be assigned a landing time when it enters the approach zone or shortly thereafter, and that the system will guide the aircraft in such a way that it can maintain safe separation and gradually stabilize its time schedule so as to land at the assigned time with very small error. With this concept in mind azimuth progress control appears to involve four basic aspects of the necessary guidance:

- (1) Maintain safe separation
- (2) Provide a means of scheduling on curved paths
- (3) Stabilize azimuth schedule to correct time schedule errors
- (4) Provide a speed reduction procedure which is flexible yet permits accurate scheduling.

A discussion of these functions, showing how they may be considered separately or in combination follows. Figures 2 and 3 will be used for illustration. For the purpose of isolating the elements of guidance under azimuth control, we can continue to assume level flight. However, one of the first steps in formulating complete approach systems would be to set up a relation between altitude and azimuth schedules.

(1) Maintain Safe Separation

A distinction will be made between a sector in which the stream of aircraft have merged into a common course, and sectors which may be considered as distinct extensions of the routes which approach the airport. The former will be called a "confluence sector", and the latter "individual sectors". In Figure 2 the central circle represents a "confluence sector" and the spirals which enter the circle are "individual sectors", both under azimuth progress control. The circle and the spirals should each be considered as representative of a family of curves with radius proportional to speed of aircraft.

Use of azimuth control to maintain safe separation would probably be associated with one or both of the functions (3) and (4) above: time schedule stabilization, and guidance during deceleration. However, it might also be a distinct phase of an integrated approach plan. For example, the "confluence sector" in Figure 2 might serve as a way of merging the stream of aircraft coming from all directions into a single sequence for runway

approach. Entry to such a "confluence sector" might be along fixed paths, e.g., straight lines tangent to the circle, or might be along "individual sectors" of azimuth control, as represented by the spirals in Figure 2.

Figure 2

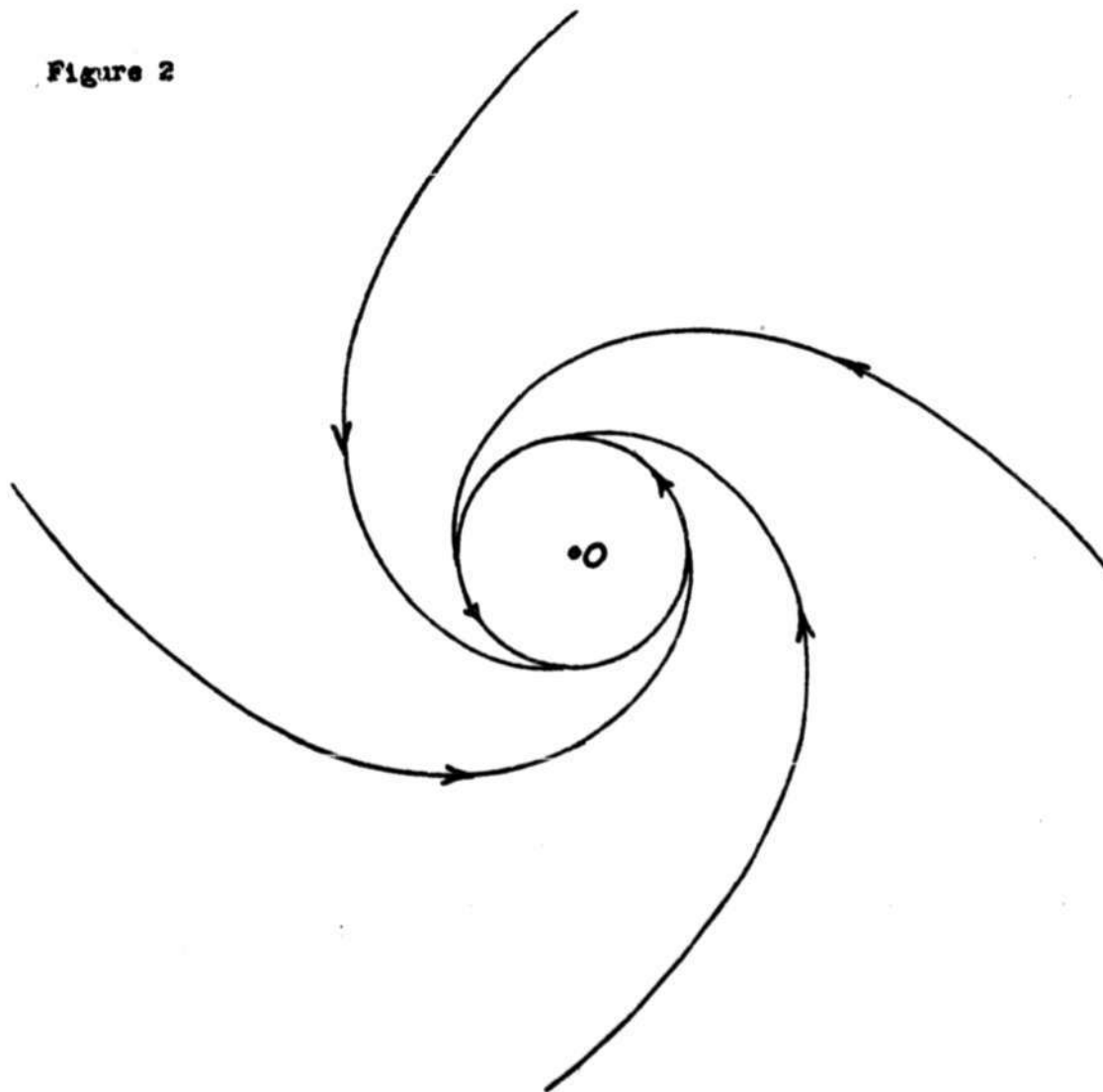
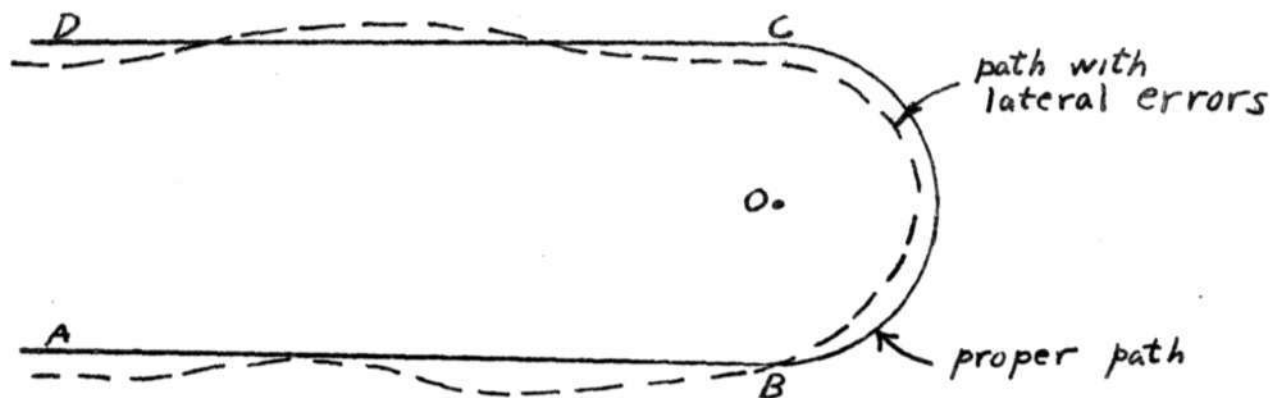

Figure 3



It should be noted that each aircraft must enter a "confluence sector" under azimuth schedule tolerances determined by the azimuth spacing on the sector; in other words a high degree of schedule accuracy must be attained prior to entry. For example, if successive aircraft are to be 60° apart, then the error at entry cannot exceed about 15° .

(2) Scheduling on Curved Paths

The following example will indicate the possible advantage of azimuth control for scheduling flight progress on curved paths.

Consider a U-shaped path, as in Figure 3 and assume that it is necessary to maintain a precise schedule along the path. We do not yet know what precision will be possible, but some assumptions will be made here in order to illustrate the differ-

ences between fixed paths and azimuth progress control.

Let us assume that air speed can be held within 3% of an assigned value, that lateral deviations from an assigned path will not exceed 0.2 mile, and that azimuth can be held within 5° of an assigned schedule. The straight segments AB and CD in Figure 3 are under fixed path guidance. On the semicircle BC about the point O we will compare fixed path guidance with azimuth progress control. Let the nominal radius of the semicircle be 2 miles.

A geometric difference between fixed path guidance on straight paths and curved paths should first be noted. Along straight segments, lateral deviations do not introduce appreciable errors in longitudinal progress, but on a curved section the error can become quite significant. For example consider a straight line 6 miles long, and assume that heading is held within $\pm 10^\circ$ of the direction of the path. The schedule error caused by lateral deviations over the 6 miles could not exceed 0.1 mile:

$$6 \times (1 - \cos 10^\circ) = .09.$$

The semicircle of 2 mile radius is also about 6 miles long. A continuous lateral deviation of 0.2 mile on the semicircle could introduce a progress error of about 0.6 mile: $2\pi - 1.8\pi \approx 0.6$. It would perhaps be better to assume that under maximum lateral deviation of 0.2 mile, the absolute value of the average deviation cannot exceed about 0.1 mile. The progress error on the semicircle could then be up to 0.3 mile; still a factor of 3 larger than on the straight path.

For comparison between the fixed path semicircle and azimuth progress control we will compare errors in terms of time rather than distance. On the fixed path, we have $t = \frac{S}{V}$

$$\Delta t \approx \pm \frac{\Delta S}{V} \pm S \frac{\Delta V}{V^2} = \frac{1}{V} \left(\pm \Delta S \pm S \frac{\Delta V}{V} \right) \dots\dots(3.1)$$

where t = time to traverse the semicircle

S = length of the semicircle = 2π miles

V = air speed. Assume 120 m.p.h. = 2 miles/minute

ΔS = linear progress error due to lateral deviations;
assume 0.3 mile on the basis of the preceding paragraph

$\frac{\Delta V}{V}$ = air speed percentage error, assumed 3%

Then in our example, the maximum time error on the fixed semicircle is $\Delta t \approx .25$ minute.

For azimuth progress control

$$\Delta t = \Omega \Delta \theta \dots\dots(3.2)$$

where $\Omega = \frac{V}{R}$ = azimuth rate

$\Delta \theta$ = maximum deviation from azimuth schedule

In the example, $\Delta \theta = 5^\circ = 0.09$ radian

$$\Delta t = \frac{2}{2} \cdot 0.09 = 0.1 \text{ minute}$$

Thus in this example azimuth control has the advantage.

Speed error does not harm the azimuth system, the result being simply a small change in radius. On completing the semicircle the lateral deviation due to change in radius can be stabilized on the subsequent straight path without appreciable effect on the schedule.

The above example is not intended to prove that azimuth progress control is superior on curved paths, but rather to indicate that it does have possible advantages, depending on the maneuvers required and on the guidance system errors actually attainable.

(7) Time Schedule Error Reduction

Use of azimuth control to stabilize time schedules can be considered from several points of view depending on the azimuth error attainable.

The ultimate objective would be to attain azimuth stabilization to an accuracy corresponding to the highest time accuracy needed for precise scheduling in the final stages of approach. Other studies have suggested that time accuracy of the order of ± 5 seconds is desirable at the beginning of the glide path, this precision to be attained gradually as the aircraft proceeds through the approach zone. To meet this demand an azimuth progress control system would have to stabilize azimuth to within $\pm 5^\circ$, assuming $1^\circ/\text{second}$ azimuth progress rate. If this is attainable, aircraft might enter a "confluence" sector with time error tolerances larger than 5 seconds, say up to 15 or 20 seconds and be stabilized to within the 5 second tolerance by the time they leave the confluence sector. In this case it would be desirable to have the confluence sector be the stage of guidance immediately preceding the glide path. (However this would pose

the problem of providing azimuth control about reference points which change with change of landing runway. See Section 5a for further comments.)

If azimuth stabilization cannot meet the suggested ultimate objective, it may, however, meet the need for intermediate steps in schedule stabilization. For example, assume in Figure 2 that aircraft on the confluence sector are to be scheduled 60° apart. The tolerance for each aircraft would be about $\pm 15^{\circ}$. As noted in (1) above it would be necessary to achieve this accuracy before the aircraft reached the confluence sector. Azimuth control on the spiral individual sectors might serve to reduce time errors from something initially of the order of ± 2 minutes down to ± 15 seconds by the time of joining the confluence sector. In this case the individual sectors would serve for stabilization sufficient to permit merging of paths.

Finally, if azimuth control accuracy is still poorer, the merits of the idea would be much decreased, but some possibilities might still remain. For example controlled flight time delays might be introduced by use of azimuth control about Omni-Range stations adjacent to the approach zone. Instructions for such a maneuver might come from the central approach control.

The three examples above illustrate the concept that an integrated approach plan will probably consist of several stages of time schedule stabilization. Azimuth control has been suggested for each stage provided the necessary azimuth accuracy can be attained.

(4) Speed Reduction

The fourth aspect of approach guidance for which azimuth control appears to have merit is that it permits maintaining schedules during deceleration from cruising speed to approach speed without rigid specification of the time and rate of deceleration. Reduction of speed corresponds to moving inward on a family of radially similar paths. In the course of large speed changes some displacement from proper azimuth is to be expected, and the magnitude of this displacement will be examined later.

It is possible to consider a variety of ways in which azimuth control could serve as part of an integrated approach plan on the basis of the above four functions. However, no attempt will be made here to catalogue all possibilities as this will depend on comparison and interrelation of azimuth control with other aspects of guidance: altitude control, speed control, fixed path guidance, etc. Figure 2 has already served for partial illustration. Preliminary studies of integrated approach plans based largely on azimuth control have been presented by W. G. Welchman in reports E-2001 and E-2007.

In E-2001 azimuth control was proposed in a form which we have termed the "spiral staircase". It was proposed that aircraft enter a "confluence sector" on straight paths, and proceed under azimuth progress control while reducing altitude and speed in preparation for landing. The spiral staircase idea encompassed three of the above described functions of azimuth control: safe

separation, speed reduction, and improvement of time schedule stabilization to a precision of ± 5 seconds by the time aircraft left the azimuth control sector. Subsequent study of this concept (E-2011 by D. R. Israel) indicated that the idea of entering the spiral staircase on straight line paths posed considerable difficulty.

A possible variation of the "spiral staircase" idea might be to use the "individual sectors" of Figure 2 in place of straight line entry. It might then be advantageous to have the main speed reductions take place on the "individual sectors" rather than in the confluence sector.

Further ramifications arise when one considers altitude separation in conjunction with azimuth control. For example, there might be azimuth control courses at two or more levels, and these might even involve different azimuth progress rates. Of course, in formulating integrated approach systems it will be desirable to avoid such complications if simpler schemes can be shown to be feasible.

As a final illustration, suppose that azimuth progress control is capable of the precision of ± 5 seconds which was suggested above as an ultimate goal. Then one might seek to formulate satisfactory approach patterns in which azimuth control serves as guidance for a final U turn onto a glide path. In such a plan azimuth control might be used for speed reduction scheduling in an earlier stage of the approach zone, but the speed reduction

could not occur on the final U turn as it would disturb the last stage of time schedule stabilization.

Section 4. Reference Curves

Before proceeding to some geometrical considerations concerning integration of azimuth control into complete approach plans, several "reference paths" will be formulated analytically. Following the lines of Section 2, $\theta(t)$ and $\beta(t)$ (azimuth and heading schedules) will serve as the principal specification of the curves. "Reference functions" will be signified by the subscript, i , -- $\theta_i(t)$, $\beta_i(t)$ -- to indicate input to the control system. The subscript will distinguish the reference functions from actual paths $\theta(t)$, $\beta(t)$, $r(t)$ which deviate from the reference paths under various disturbances.

It is necessary first to make assumptions about the types of reference path which will be feasible. One possibility is that engineering requirements or further analysis of guidance will require that the system provide a single constant azimuth progress rate for all aircraft. This concept was in fact sufficient for the "spiral staircase" proposal which was summarized above. Under this assumption the only "reference paths" available are circles. ("Reference paths" were defined in Section 2 on the basis of constant altitude. In the "spiral staircase" there is constant rate of descent so that the reference paths become helices.)

The more general viewpoint will be taken here that variable reference functions, $\theta_i(t)$ and $\beta_i(t)$, can be transmitted

to each aircraft in the system. However, it will be assumed that these functions should be of simple form, preferably of a type which lends itself to use of "analogue" devices in the aircraft control system. Simple trigonometric functions should be considered acceptable; they will in fact soon be used in "course line" computers. Simple logarithmic and exponential relations can also be mechanized.

It does not appear unrealistic to permit fairly complex functions, on the assumption that the main burden of computation or data storage could be carried out in ground station equipment, but the simpler assumption is broad enough for present purposes.

Simple implicit function descriptions of the reference functions will be considered to be admissible just as well as explicit formulas, e.g. $\sin \theta_1 = Kt$ is as good as $\theta_1 = \arcsin Kt$; and $\beta_1 = \frac{1}{4} \theta_1$ with β_1 given in terms of θ_1 rather than in terms of t is satisfactory.

The radial functions $r_1(t)$ with parameter V will also be given. The remarks about complexity of functions do not apply here since this function does not enter into the control system.

Geometric analyses, used to arrive at the more complicated of the following reference functions, will be given in Section 7, only the final results being given here. Each set $\theta_1(t)$, $\beta_1(t)$ satisfies equation (2.5). The $\theta_1(t)$ functions are for the initial condition $\theta = 0$ at $t = 0$. Time and angle displacement constants to represent different aircraft in the system can readily be introduced.

Circles centered at the origin represent the heart of the azimuth control idea, and will be the main subject of control system analysis. Let Ω be a constant rate of angular progress about point O. The "reference functions" are:

$$\begin{aligned}\theta_1 &= \Omega t \\ \beta_1 &= 0 \\ r_1 &= v/\Omega\end{aligned}\quad \dots(4.1)$$

Eccentric circles might serve as entry paths, e.g. eccentric semicircles in Figure 2 in place of the spirals, or perhaps for other aspects of guidance. Flight on eccentric circles does not correspond to constant azimuth progress rate, but has the advantage of being a simple flight operation as far as the aircraft itself is concerned. It may turn out that the servo system in the aircraft can be designed satisfactorily for circular reference paths, regardless of whether the circle is centered or not with respect to the ground station, while spirals or other curved reference paths would pose more difficult engineering problems. The reference functions for eccentric circles, with the ground station, O, inside the circle, are:

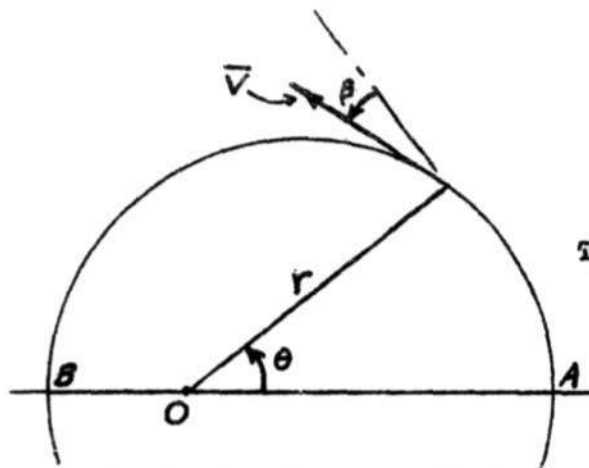

Figure 4. Eccentric Circle

Let $K =$ a desired ratio OA/OB

$$C = \frac{K-1}{K+1}$$

$p =$ desired rate of turn of the aircraft on the eccentric circle

$$\left. \begin{aligned} \text{Then: } \tan \theta_1 &= \frac{\sin pt}{\cos pt + C} \\ \beta_1 &= \theta_1 - pt \\ r_1 &= \frac{y}{p} \sqrt{1 + C^2 + 2C \cos pt} \end{aligned} \right\} \dots(4.2)$$

Circles which pass through the origin are a special case which permit constant azimuth rate. This may be worth considering as a form of guidance in which there is azimuth progress control over part of the reference path followed by a guidance effect which leads the aircraft toward a fixed point. (In Figure 5, as the aircraft approaches point O, β approaches 90° . As noted at the end of Section 2, and discussed in Section 6, at large β the control system would no longer behave along the lines which are being analyzed in this report, and would require separate analysis.)

h-189

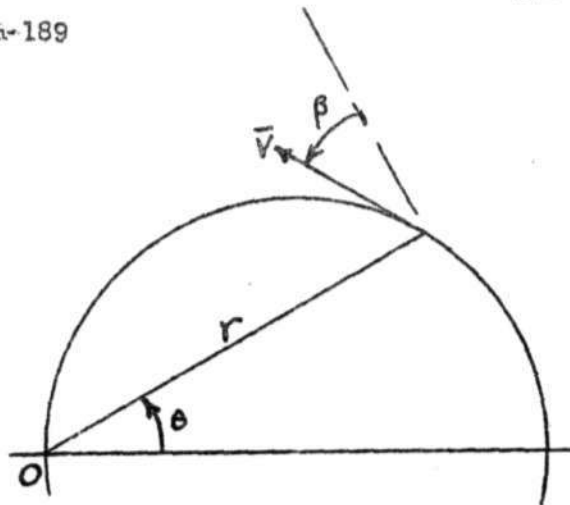

$\Omega =$ constant azimuth
progress rate

$$\begin{aligned} \theta_1 &= \Omega t \\ \beta_1 &= -\Omega t \quad \dots(4.3) \\ r_1 &= \frac{V \cos \Omega t}{\Omega} \end{aligned}$$

Figure 5. Circle Through O

Equiangular spirals are defined as curves for which β is constant. The reference functions are:

$$\theta_1 = \frac{1}{C_1} \log(C_1 C_2 t + 1)$$

$$\beta_1 = \text{constant}$$

where $C_1 = \tan \beta_1$ and $C_2 = \dot{\theta}(0)$... (4.4)

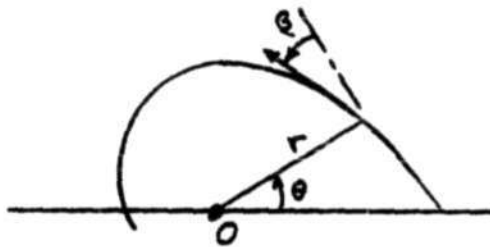

$$r_1 = \frac{V(C_1 C_2 t + 1) \cos \beta_1}{C_2}$$

Figure 6. Equiangular Spiral

A more general class of curve is obtained by setting: $\beta = a + b\theta$, with a and b constant. An analysis of these curves will be given in section 7. The case with $b = -\frac{1}{2}$ turns out to be the cardioid. The reference functions for this case are:

$$\left. \begin{aligned} \sin \frac{\theta_1}{2} &= \frac{t}{2c} \quad [c = 1/\dot{\theta}(0)] \\ \beta_1 &= -\frac{1}{2} \theta_1 \\ r_1 &= \frac{cV}{2} (1 + \cos \theta_1) \end{aligned} \right\} \dots(4.5)$$

Actually, the relation $\beta = a + b\theta$ includes all of the curves discussed above except the eccentric circles. The case $a = 0, b = 0$ represents circles centered at the origin; $a \neq 0, b = 0$ gives the equiangular spiral; and $b \neq 0$ gives more general curves of which circles through the origin and the cardioid are special cases. (When $b \neq 0$ the value of b determines the type of curve, and a is simply a parameter which rotates the curves about the origin.)

Since $\beta = \psi + \theta$, all of the curves discussed may also be expressed by $\psi = a' + b'\theta$. In other words, whether we use β (relative heading) or ψ (compass heading) there is a linear relation between heading and azimuth for most of the azimuth control schedules considered thus far.

Section 5. Geometrical Aspects of Integration of Azimuth Control into Complete Approach Plans

Since the report is an analysis of azimuth progress control as a guidance technique, this section is intended to bring out additional points about the technique rather than analyze complete approach plans. The following points will be discussed:

- (a) Location of azimuth reference center points
- (b) Adjustment of azimuth schedules for particular conditions
- (c) Geometrical examination of paths which correct time schedule errors
- (d) Optimum value of β when leaving an azimuth control sector.

Section 5a. Location of Center Point

Thus far the discussion has implied that if azimuth control is feasible, an Omni-Range station would serve as the center point O. On this basis the idea of azimuth control is especially simple and therefore attractive, and led Welchman to formulate the "spiral staircase" approach plan. More detailed examination of his proposal uncovered complicating features which offset some of the initial simplicity.

The present section will take the point of view that, if there is enough advantage, it will be feasible to have several center points for azimuth reference. On the basis of the present stage of development of air guidance equipment, coordinate transformations in the aircraft appears to be the most likely way in which the center for azimuth control might be transferred from point to point. Offset course computers now under development are simply equipment for transforming from polar coordinates, provided by Omni-Range and LME, to Cartesian coordinates. Transformation to polar coordinates about a new center would require the additional step of going from Cartesian coordinates back to polar coordinates about a new center, or could combine the operations into a direct polar to polar transformation. This may not be unduly complicated, and in fact, guidance plans which call for flight on fixed curves may necessitate essentially the same operations. Alternatively, assuming that computing machines will be needed as part of the ground station equipment, it may

become desirable to make coordinate transformations on the ground and transmit the results to each aircraft. Finally, the use of two or more Omni-Range stations in the approach zone might be the best solution. The system might need only one Omni-Range at a time, depending on the direction of the wind.

It is not possible to consider all of the configurations which may arise in approach guidance, but in order to show an aspect of the geometrical layout in which location of azimuth reference centers would be a problem, the relation between azimuth control and the final glide path will be examined.

A single runway will be discussed. Similar considerations would apply to parallel runways or runways in several directions. The final leg of an approach guidance system will be assumed to be a straight glide path about 5 miles long. The glide path may be on either end of the runway depending on wind direction.

Consider first the geometrical layout required to guide an aircraft by azimuth control directly onto a glide path. In Figure 7 AB and DC are the glide paths for the airport runway. BC. AE is a line perpendicular to AB, and O is an azimuth center on AE for azimuth controlled turn onto the glide path AB. O' is a corresponding point for use of the glide path DC. It will be shown that a single azimuth reference point such as O'' midway between the two glide path entry points, A and D, could not cover both glide paths.

Assume that the rate of rotation about O is 1 radian/minute

(slightly less than 1 degree/second), and that approach speeds range from 80 to 140 m.p.h., or $1\frac{1}{3}$ to $2\frac{1}{3}$ miles/minute. The

Figure 7

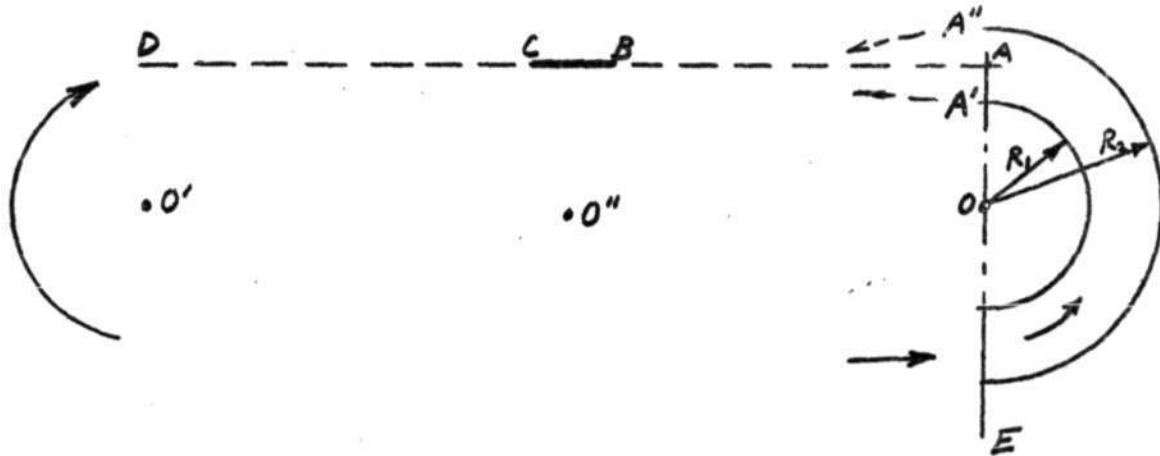

point O should be located $1\frac{5}{6}$ miles from A, thus an aircraft at the slowest speed of $1\frac{1}{3}$ miles/minute has as reference path the circle of radius $R_1 = 1\frac{1}{3}$ miles, and the fastest aircraft has as reference path the circle of radius $R_2 = 2\frac{1}{3}$ miles. AA' and AA'' are each $\frac{1}{2}$ mile. On a glide path 5 miles long, an initial deviation of $\frac{1}{2}$ mile is permissible, and path length differences from any point between A' and A'' to B are quite small. If the point O is moved along AE further from A, (corresponding to a decrease in azimuth rate about O), the ratio $\frac{R_2}{R_1}$ will not change since it corresponds to the ratio of permissible approach speeds. Thus as O moves outward $A'A''$ becomes larger and soon the points

A' and A'' are too far from the center of the glide path (unless the glide path is lengthened.) Moreover as O is moved further from A , the schedule errors at the head of the glide path increase, since the azimuth rate decreases. (See Eq. (6.2).) Thus it does not appear possible to use a single Omni-Range at a point such as O'' to provide azimuth progress control directly onto both glide paths, AB and DC .

If azimuth control directly onto a glide path does not turn out to be desirable, but merging of aircraft paths by means of azimuth control is desirable, then the situation may be as in Figure 8. After merging of paths under azimuth control about O ,

Figure 8.

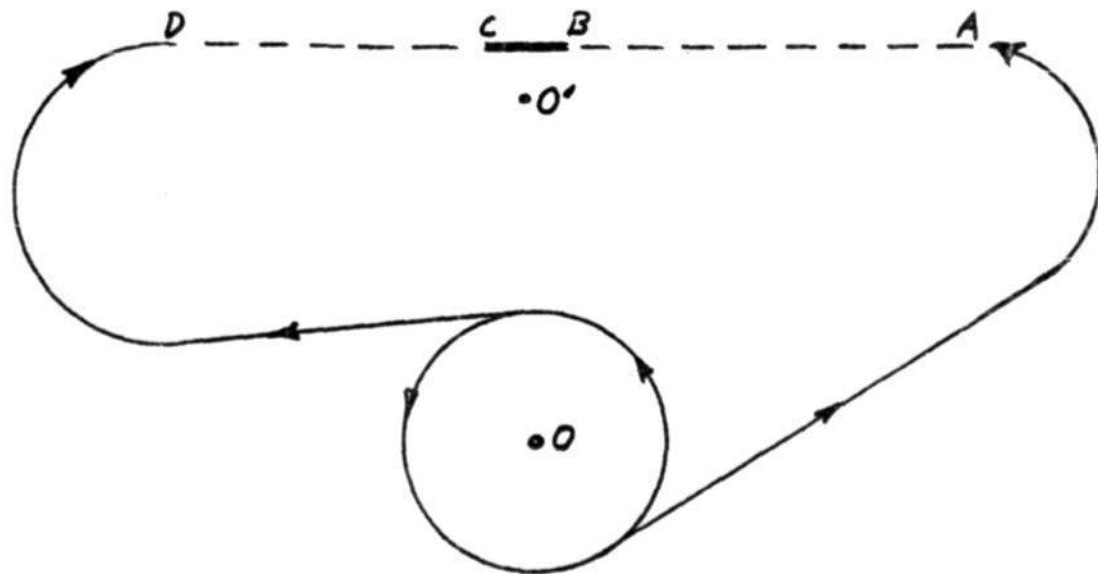

each aircraft is given fixed path guidance to the head of the glide path. The location of point O is not critical. Possibly it can be at O' very near the runway.

Figure 8 represents the preferable concept of azimuth control about a single Omni-Range station. Figure 7, on the other hand, would require an Omni-Range adjacent to each glide path or facilities for polar-to-polar coordinate transformation.

Section 5b. Adjustment of Azimuth Schedules for Particular Conditions

Up to this point it has been assumed that in a given sector the $\theta_1(t)$, $\beta_1(t)$ functions would be the same for all aircraft, except for shifts in time. On that assumption the "reference paths" were shown in section 2 to be a family of radially similar curves, with radius proportional to speed, V. Instead, it would be possible to set up different θ , β schedules for different aircraft according to speed, altitude, wind or other particular conditions.

Suppose, for example, that it is desired to provide azimuth control which causes a family of paths to converge to a common point, as in Figure 9. Azimuth control is about point O, and all paths are to converge at A, and be headed toward B. θ , β schedules could be determined corresponding to any nominal curve such as C_1 , C_2 , or C_3 , and would provide azimuth progress control. Aircraft would not be guided by the curves themselves, but rather by corresponding azimuth and heading schedules. Deviations from expected speed at A would produce lateral errors at A, but that would presumably be less important than maintaining the desired forward schedule.

Figure 9.

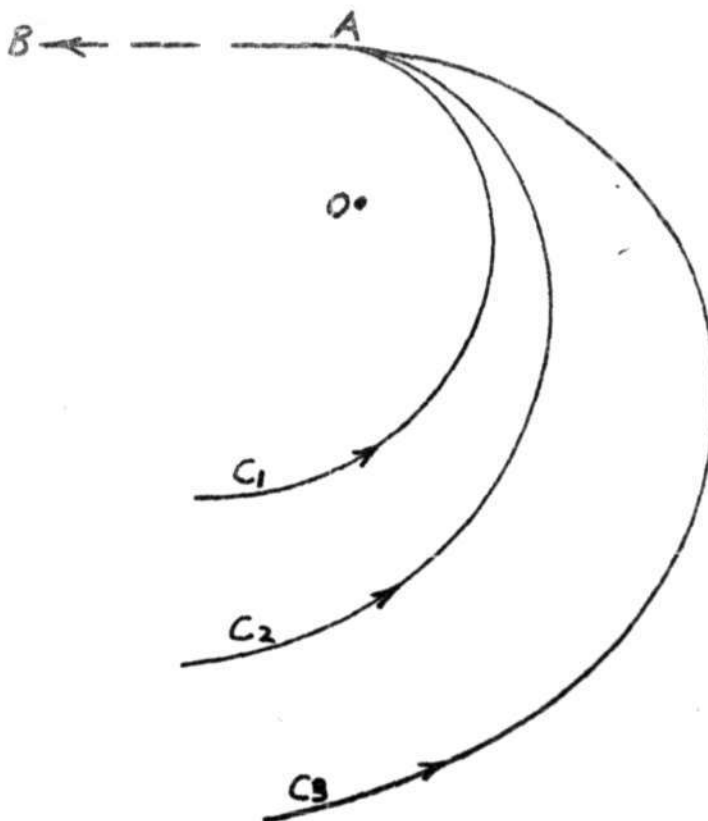

This formulation of azimuth control is more general than that used in earlier sections, and may turn out to be desirable if azimuth control proves to have advantages for scheduling on curved paths, as discussed in Section 3, item (2). However, there are important disadvantages compared to use of fixed θ , β functions:

- (1) Azimuth control would no longer immediately provide safe separation schedules. Instead it would be necessary to examine the schedules set up for adjacent

aircraft to see whether they provide for safe separation at all times. Once this had been established the system would, of course, be just as safe as that based on fixed θ , β functions.

- (2) The guidance system would require more complex facilities. In particular more computation would be required and more instructions would have to be transmitted from ground to air.

Thus far in examining configurations for guidance, patterns such as Figure 9 have not appeared to be necessary. However, schedule adjustments will have to be considered in studying the effects of wind on azimuth control (Section 2/).

Section 5c. Schedule Corrections

Servo system analysis later in the report will provide a general basis for studying the stabilizing characteristics of azimuth progress control systems. A purely geometric examination here will serve as a preliminary to the servo analysis.

Consider a semicircular reference path, p_0 , in Figure 10. Point A is assumed to be the starting point for azimuth progress control. p_1 is assumed to approximate the path an aircraft would take if it were behind schedule at A by the maximum amount which could be corrected in 180° of azimuth progress control. Similarly p_2 is for the maximum amount ahead of schedule.

p_1 and p_2 are spirals which have a linear relation between β and θ . For p_1 the relation (in radians) is $\beta = -\frac{11}{4} + \frac{1}{4}\theta$, and for p_2 it is $\beta = \frac{11}{4} - \frac{1}{4}\theta$. (Spirals of this type were discussed

Figure 10.

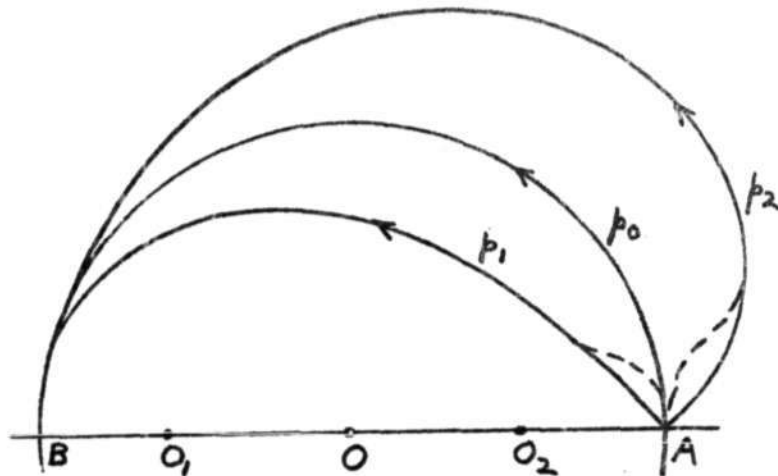

in Section 4 as possible "reference paths" but here are used as assumed correction paths relative to the reference path, p_0 . The center points for constructing p_1 and p_2 are actually at O_1 and O_2 respectively, which does not matter here, since all that is wanted is that the curves represent probable behavior under azimuth control, regardless of how the curves are constructed.) p_1 leaves A at $\beta = -\frac{\pi}{4} = -45^\circ$, that is with a large heading correction relative to the reference path, p_0 . It reaches B where the aircraft is assumed to be back on schedule with $\beta = -\frac{\pi}{4} + \frac{\pi}{4} = 0$, i.e. tangentially to p_0 . Similarly p_2 leaves A at $\beta = +45^\circ$, and also arrives at B tangentially. The broken lines near A indicate that an aircraft would actually have to curve gradually onto p_1 and p_2 .

The details of the analysis will be given in Section 8.

The results are as follows: Let Ω be the scheduled azimuth rate about O in radians per minute. The time on p_0 for an aircraft at speed V is $T_0 = \pi/\Omega = 3.14/\Omega$. At the same speed time on p_1 would be $T_1 = 3.04/\Omega$ and on p_2 would be $T_2 = 3.76/\Omega$ (Ω is a single number associated with the center O ; azimuth rates about O_1 and O_2 do not enter the calculation.)

$$\text{Thus we have, } T_0 - T_1 = + .10/\Omega \text{ minute}$$

$$T_2 - T_0 = + .62/\Omega \text{ minute}$$

At $1^\circ/\text{sec.}$ azimuth rate, Ω is very near 1 radian/minute.

$T_0 - T_1$, the assumed maximum corrections for an aircraft behind schedule is only 6 seconds, while $T_2 - T_0$, the assumed maximum correction when ahead of schedule is 37 seconds. p_1 and p_2 are in a sense equivalent inward and outward correcting paths since both leave A with $\beta = 45^\circ$, and rejoin the semicircle at B with $\beta = 0^\circ$. There is thus a large asymmetry in the capacity to correct schedule errors, as noted in Section 2.

The inward correction on path p_1 is surprisingly low. Before interpreting the implications for azimuth control two factors should be taken into account. (1) The control system is not expected to achieve perfect scheduling at B , but rather scheduling within some tolerance, say $\pm 5^\circ$, corresponding to time error range of ± 5 seconds at $\Omega = 1$. (2) An inward correction path could cross the line OB at a point nearer to O . On the basis of point (2) an estimate of the best time saving on an inward path in the above example appears to be about 12 to 15 seconds. This would permit

reduction of an error of 15 to 20 seconds at A to within the system tolerance of ± 5 seconds at B, giving a possible "stabilization ratio" of about 3 to 1 for behind schedule flights over a 180° sector.

Section 5d. Final Value of β

Section 2 stated that β schedules would be limited to β between -30° and $+30^\circ$, and reasons are given for the limitation in Section 6. This section will point out the best schedule accuracy will be obtained if $\beta_i = 0^\circ$ at the end of azimuth control.

"Error blocks" for an aircraft moving under azimuth control are sketched in Figure 11. ϵ_θ is the maximum deviation from scheduled azimuth at any instant, and ϵ_r the maximum lateral

Figure 11.

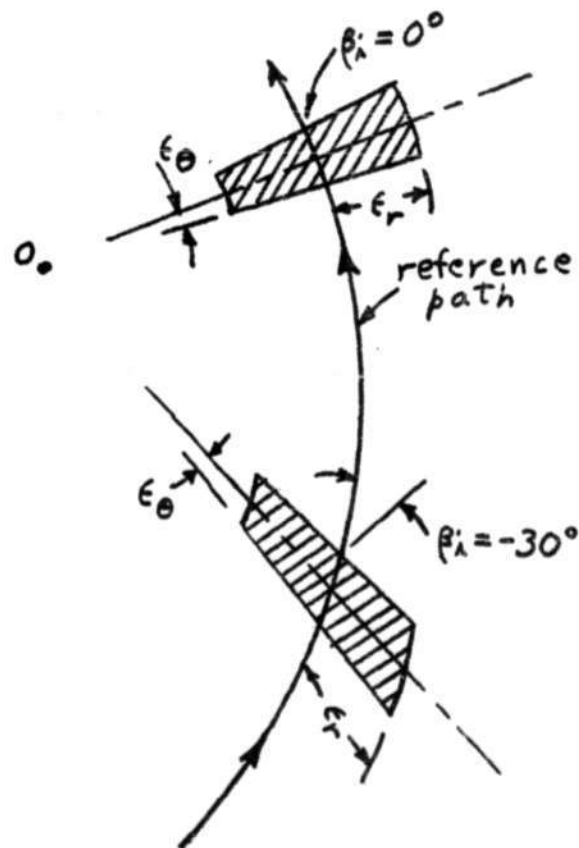

deviation from the reference path. The upper wedge is at a point where the heading reference called for is $\beta_1 = 0^\circ$, and the lower wedge where $\beta_1 = -30^\circ$. The radial range ϵ_r is shown relatively large, since azimuth stabilization requires fairly large lateral deviations, as has been seen in Section 5c. Speed errors also account for part of ϵ_r , but stabilization would generally be the major part.

During flight on an azimuth control sector schedule accuracy is measured by ϵ_θ alone. However, at the end of azimuth control ϵ_r must also be considered. Figure 12 shows the end of azimuth control at two values of β_1 . On the left side of the figure

Figure 12

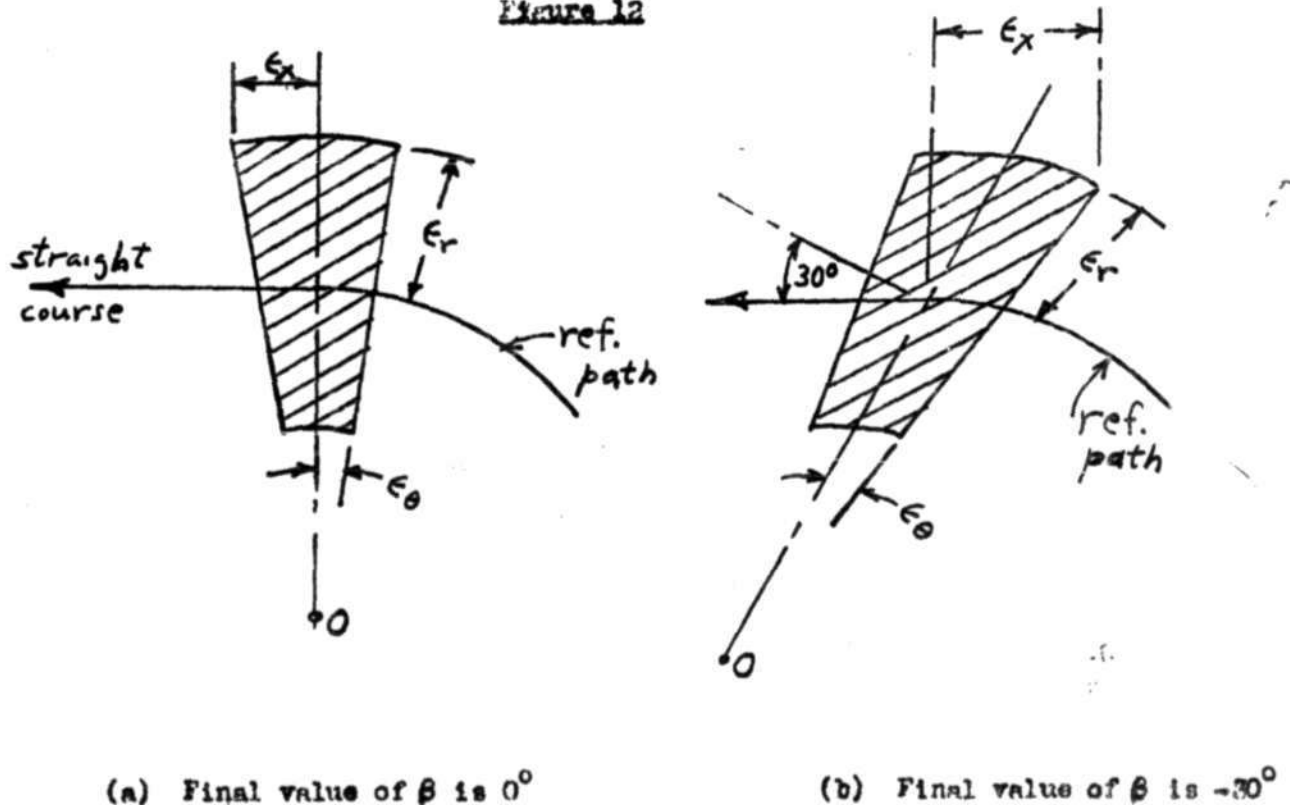

the final value of β_1 is 0° , and on the right side it is -30° . The distance ϵ_x at the top of each wedge is the maximum schedule error at which azimuth control may deliver the aircraft onto a subsequent straight path. In Figure 12(a), ϵ_x is given approximately by :

$$\epsilon_x = \frac{V}{\Omega_1} \epsilon_0 \quad \dots(5.1)$$

Ω_1 = final value of azimuth rate

In Figure 12(b) we have approximately:

$$\epsilon_x = \frac{V}{\Omega_1} \epsilon_0 + \epsilon_r \beta_1 \quad \dots(5.2)$$

β_1 = final value of β_1 in radians

With $\beta_1 = 30^\circ = \frac{1}{2}$ radian, and assuming $\epsilon_r = \frac{1}{2}$ mile, the radial deviation can contribute $\frac{1}{4}$ mile to the schedule error, ϵ_x . Thus for maximum precision the end of azimuth control should be as in Figure 12(a) with $\beta = 0^\circ$.

Appendices

Section 6. Discussion of Limiting Factors

The following is a point by point discussion of the limiting factors which were listed at the end of Section 2.

(a) Asymmetry. It is obvious that the path of an aircraft in the system can be lengthened more than it can be shortened. However, consider a circular reference path and consider nearby curves outside and inside the circle which represent schedule

correcting paths for aircraft ahead of or behind schedule. If the correcting paths are sufficiently near the reference path the correction is symmetric. However, to make appreciable corrections during not too large an azimuth advance, the correction paths must diverge appreciably from the reference path and the asymmetry becomes quite important. An example was given in Section 5c.

(b) Use of Heading as well as Azimuth. The heading, in the form β , or alternatively the compass heading, ψ , has already been introduced in Section 2 as intrinsic to the idea of azimuth progress control. Since the heading reference function is a direct consequence of the azimuth schedule, via equation (2.5), it may be possible to reformulate the idea in a way which does not present the heading explicitly. One might then examine the possibility of stabilizing the system using azimuth error data, without heading error data. However, the analysis of stabilization methods later in the report will show that heading error information is essential. It appears to be the only source of second derivative ($\ddot{\theta}$) information, without which the system cannot be stabilized. The only other possible source of $\ddot{\theta}$ is actual differentiation of θ measurements to the second order. Considering the probable nature of the θ measuring system, this alternative appears to be entirely out of the question. In other words use of heading on a parallel footing with azimuth enters naturally in Section 2, and is also essential to stabilization.

(c) Bank and Roll Limits. The bank angle limitation and the rate of roll limit will determine limits on feedback parameters in the stabilization system. Geometrically they appear as limits on the curvature and rate of change of curvature. In coordinated turns with relatively small bank angles (up to 30° may be considered as relatively small) the radius of curvature is given approximately by $\rho = \frac{V^2}{g\phi}$, and with ϕ limited to 30° , the smallest available radius of curvature is given approximately by $\rho_{\min.} = \frac{2V^2}{g}$.

(d) Azimuth Progress Rate. Consider a constant azimuth progress rate, Ω . The heading reference function for concentric circles may be written $\phi = -\Omega t$, and we have $\dot{\phi} = -\Omega$. Substituting this in Equation (2.2) gives $\Omega = -\frac{g\phi}{V}$ (6.1)

Bank angle is limited to 30° , but the stabilized value on a reference path must be smaller, in order to provide leeway for correcting action. Assume that the maximum stabilized ϕ is 15° . Then by (6.1), the larger the value of V which may enter, the smaller Ω must be. If the system admits aircraft up to about 300 m.p.h., Ω cannot exceed $1^\circ/\text{second}$. But if aircraft enter the azimuth control zone only at reduced speeds in preparation for landing, say up to 150° miles/hr., then Ω can be raised to $2^\circ/\text{second}$.

(e) Time Accuracy. Let ϵ_θ be the maximum error of the θ measurement system. Then for concentric circle reference paths, the maximum error in time schedule, ϵ_t , may be written $\epsilon_t = \frac{K\epsilon_\theta}{\Omega}$... (6.2) where K would be 1 if the stabilization system were perfect, but actually will be considerably larger than 1. (6.2) indicates that

a high azimuth rate, Ω , is desirable to reduce the time error. This is simply a way, suitable for this problem, of expressing the fact that linear accuracy in the θ direction improves as the radius decreases. Simply to fix ideas, assume $\epsilon_{\theta} = \pm \frac{1}{2}^{\circ}$, $\Omega = 1^{\circ}/\text{second}$, $K = 10$, then $\epsilon_t = \pm 5$ seconds.

(f) Limitation of β to $\pm 30^{\circ}$. This limitation is an optional one, since there is of course nothing about the aircraft itself which limits β . The limitation to $\pm 30^{\circ}$ will be applied to reference paths, and correcting action will be permissible up to say $\beta = \pm 45^{\circ}$. The reasons for the limitation are as follows:

- (1) Paths involving larger values of β call for quite different lines of attack on setting up a stabilization system.
- (2) One of the main ideas of azimuth control is to provide safe separation between aircraft by separation in azimuth. The azimuth separations associated with given time separations become smaller as β becomes larger, as indicated in Figure 13.
- (3) Along the lines of item (e) on time accuracy, for a given angle error, ϵ_{θ} , the corresponding time schedule error ϵ_t increases as β increases. The effect is small for β not exceeding $\pm 45^{\circ}$, but then gradually becomes large.

Figure 13.

Small β

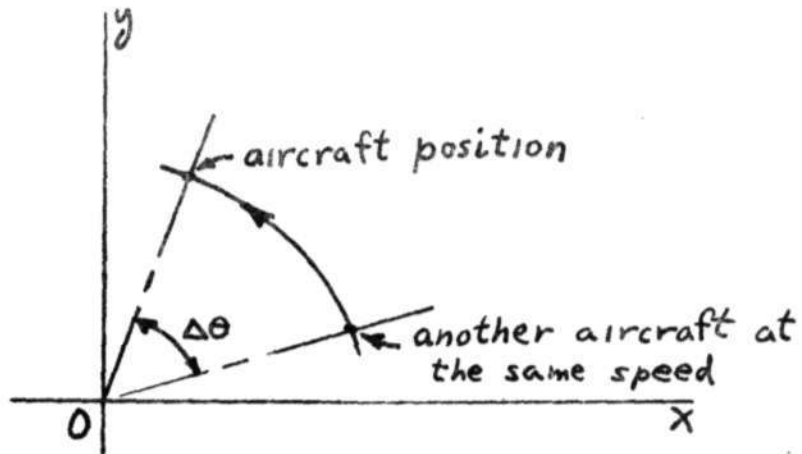

Large β

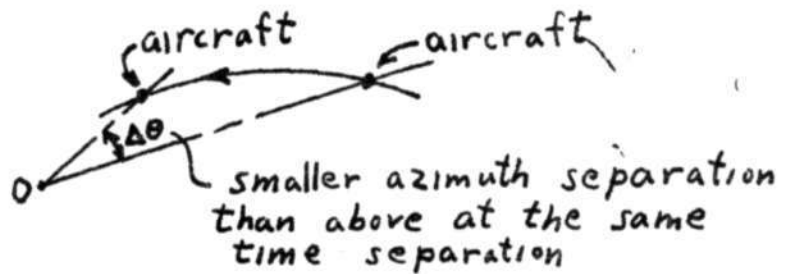

Section 7. Notes on Reference Functions (Supplement to Section 4).

(1) At constant speed, V , and at constant azimuth progress schedule, $\dot{\theta} = \Omega$, the only possible reference paths are circles centered at the origin or circles which pass through the origin:

Equation (2.5) was, $\ddot{\theta} + (\dot{\theta}^2 + \dot{\theta}\dot{\beta}) \tan \beta = 0$

With $\dot{\theta} = \Omega$, $\ddot{\theta} = 0$ it becomes:

$$(\Omega + \dot{\beta}) \tan \beta = 0 \quad \dots(7.1)$$

Solutions of (7.1) are: (a), $\beta = 0$

(b), $\dot{\beta} = -\Omega$

$$\beta = -\Omega t + c = -\theta + c'$$

Corresponding to (a) we have $r = \frac{V \cos \beta}{\dot{\theta}} = \frac{V}{\Omega}$ which is a circle with center at the origin

Corresponding to (b) we have $r = \frac{V \cos(c't - \theta)}{\Omega}$, which is a circle which passes through the origin.

(2) Equiangular spiral

Equation (2.5) is convenient for setting up the equiangular spiral in the form desired here.

Let $\beta_1 = \text{constant}$

Let $C_1 = \tan \beta_1$

Then (2.5) becomes:

$$\ddot{\theta} + C_1 \dot{\theta}^2 = 0$$

Integration gives: $\frac{1}{\dot{\theta}} = C_1 t + \frac{1}{C_2}$

where $C_2 = \dot{\theta}(0)$

$$\dot{\theta} = \frac{C_2}{C_1 C_2 t + 1}$$

$$\theta_1 = \frac{1}{C_1} \log(C_1 C_2 t + 1)$$

$$r_1 = \frac{V \cos \beta}{\dot{\theta}} = \frac{V(C_1 C_2 t + 1)}{C_2} \cos \beta_1$$

(3) Spirals for which $\beta = a + b\theta$

Start with the general relation:

$$\frac{dr}{r d\theta} = \tan \beta \quad \dots(7.2)$$

With $\beta = a + b\theta$, (7.2) becomes:

$$\frac{dr}{r} = \tan(a + b\theta) d\theta \quad \dots(7.3)$$

Integrate (7.3):

$$r = c [\cos(a + b\theta)]^{-\frac{1}{b}} \quad \dots(7.4)$$

where c is an integration constant

For azimuth progress control a family of radially similar curves is desired, with radius proportional to speed, V.

(7.4) can be rewritten with $c = CV$,

$$r = CV [\cos(a + b\theta)]^{-\frac{1}{b}} \quad \dots(7.5)$$

then, $\dot{\theta} = \frac{V \cos \beta}{r} = \frac{V \cos(a + b\theta)}{VC [\cos(a + b\theta)]^{-\frac{1}{b}}}$

$$\dot{\theta} = \frac{1}{C} [\cos(a + b\theta)]^{1+\frac{1}{b}} \quad \dots(7.6)$$

(7.6) can be integrated in terms of elementary functions

whenever $(1 + \frac{1}{b})$ is an integer (positive or negative)

For example, let $b = -\frac{1}{2}$; then $1 + \frac{1}{b} = -1$, and the integral of (7.6) is:

$$\frac{1}{C}(t - t_0) = 2 \sin(a - \frac{1}{2} \theta) \quad \dots(7.7)$$

Let $a = 0$ (this amounts to rotating the base line of the polar coordinate system), and let $t_0 = 0$. Then (7.7) is,

$t = 2 C \sin \theta/2$ and with $\beta = -\frac{1}{2} \theta$ and (7.5), we have the reference functions which were given for the cardioid in

Section 4:

$$\sin \frac{\theta_1}{2} = \frac{t}{2C}$$

$$\beta_1 = -\frac{1}{2} \theta_1$$

$$r_1 = CV \cos(-\frac{1}{2} \theta_1)^2 = \frac{CV}{2} (1 + \cos \theta_1)$$

The form of the relation between r and θ shows that the curves are cardioids

(4) Construction of reference functions for eccentric circles.

Figure 14.

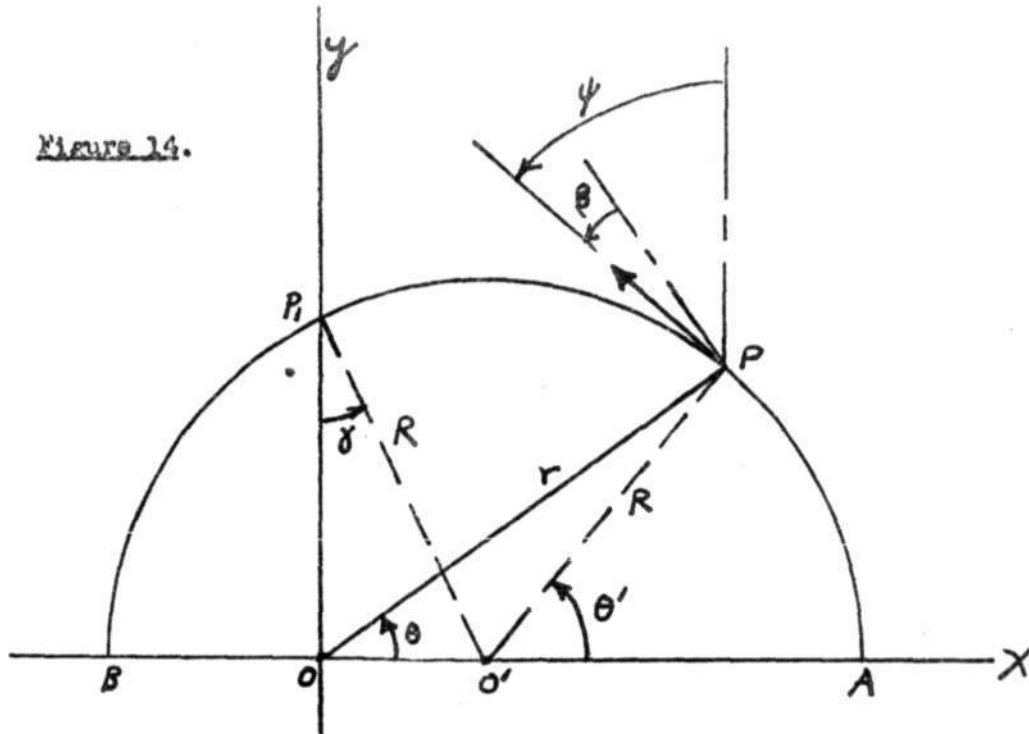

In Figure 14, O is the center of a polar coordinate system. An aircraft moves on the eccentric circle of radius R and center O' at rate of turn p. Let P be the location of the aircraft at time, t, and P₁ be the point where the circle crosses the y axis. Relations (7.8) to (7.13) can be seen from the figure.

$$\psi = -pt \quad (\text{taking } t = 0 \text{ at } A) \quad \dots(7.8)$$

$$\angle OPO' = -\beta \quad \dots(7.9)$$

(β and ψ are measured positive clockwise)

$$\frac{OO'}{R} = \sin \delta \quad \dots(7.10)$$

$$\frac{OO^1}{R} = \frac{\sin \angle OPO^1}{\sin \theta} = - \frac{\sin \beta}{\sin \theta} \quad \dots(7.11)$$

$$\theta^1 = pt \quad \dots(7.12)$$

$$\frac{r}{R} = \frac{\sin pt}{\sin \theta} \quad \dots(7.13)$$

Combining (7.10) and (7.11) gives:

$$\sin \beta = - \sin \gamma \sin \theta \quad \dots(7.14)$$

But $\beta = \theta + \phi$ (Eq. (1.1))

$$= \theta - pt, \quad \dots(7.15)$$

and (7.13) becomes:

$$\sin(\theta - pt) = - \sin \gamma \sin \theta$$

$$\sin \theta \cos pt - \cos \theta \sin pt = - \sin \gamma \sin \theta$$

$$\sin \theta (\cos pt + \sin \gamma) = \cos \theta \sin pt$$

$$\tan \theta = \frac{\sin pt}{\cos pt + \sin \gamma} \quad \dots(7.16)$$

Since $R = V/p$, (7.13) gives:

$$r = \frac{V \sin pt}{p \sin \theta} \quad \dots(7.17)$$

Using (7.16), $\frac{1}{\sin \theta} = \sqrt{1 + \frac{1}{\tan^2 \theta}} = \frac{\sqrt{1 + \sin^2 \gamma + 2 \cos pt \sin \gamma}}{\sin pt}$

Therefore, $r = \frac{V}{p} \sqrt{1 + \sin^2 \gamma + 2 \cos pt \sin \gamma} \dots(7.18)$

Let $C = \sin \gamma$, then the reference functions are given by (7.16), (7.15), and (7.18) in the form:

$$\tan \theta_1 = \frac{\sin pt}{\cos pt + C}$$

$$\beta_1 = \theta_1 - pt \quad \dots(7.19)$$

$$r_1 = \frac{V}{p} \sqrt{1 + 2C \cos pt + C^2}$$

Let $K = \overline{OA}/\overline{OB}$

C can be expressed in terms of K:

$$\overline{OA} = R + \overline{OO'} = R + R \sin \gamma$$

$$\overline{OB} = R - \overline{OO'} = R - R \sin \gamma$$

$$K = \overline{OA}/\overline{OB} = \frac{1 + \sin \gamma}{1 - \sin \gamma}$$

$$C = \sin \gamma = \frac{K - 1}{K + 1}$$

Section 8. Equations for Section 5c.

Equations (7.5) and (7.6) will be used to find the time of flight of paths p_1 and p_2 in Figure 10.

V = aircraft speed (same on p_0 , p_1 and p_2)

Ω = azimuth progress rate on p_0

$$\overline{AB} = \text{diameter of } p_0 = 2V/\Omega \quad \dots\dots(8.1)$$

On p_1 , $\beta = -\frac{\pi}{4} + \frac{1}{4}\theta$ which is of the form $\beta = a + b\theta$

with $a = -\frac{\pi}{4}$, $b = \frac{1}{4}$

By (7.5) the polar coordinate equation of p_1 (about the center O_1 in Figure 10) is:

$$r = CV \left[\cos\left(-\frac{\pi}{4} + \frac{1}{4}\theta\right) \right]^{-4} \quad \dots\dots(8.2)$$

$$\text{at } \theta = 0, r(0) = CV \left[\cos\left(-\frac{\pi}{4}\right) \right]^{-4} = 4 CV$$

$$\text{at } \theta = \pi, r(\pi) = CV \left[\cos 0 \right]^{-4} = CV$$

$$r(0) + r(\pi) = \overline{AB} = 5CV$$

$$\text{Therefore by (8.1), } C = \frac{2}{5\Omega}$$

$$\text{By (7.6), } \dot{\theta} = \frac{5\Omega}{2} \cos^5\left(-\frac{\pi}{4} + \frac{1}{4}\theta\right)$$

Therefore the time of flight on p_1 is:

$$\begin{aligned}
 T_1 &= \int_0^{\pi} \frac{2}{5\Omega} \sec^5 \left(-\frac{\pi}{4} + \frac{1}{4} \theta \right) d\theta \\
 &= \frac{8}{5\Omega} \left[\frac{1}{4} \frac{\sin \frac{\theta - \pi}{4}}{\cos^4 \frac{\theta - \pi}{4}} + \frac{3}{8} \frac{\sin \frac{\theta - \pi}{4}}{\cos^2 \frac{\theta - \pi}{4}} + \frac{3}{4} \log \tan \frac{\theta + \pi}{8} \right]_0^{\pi} \\
 &= \frac{3.04}{\Omega}
 \end{aligned}$$

Similarly on p_2 :

$$\beta = \frac{\pi}{4} - \frac{1}{4} \theta = a + b\theta$$

$$a = \frac{\pi}{4}, \quad b = -\frac{1}{4}$$

$$r(\theta) = CV \cos^4 \left(\frac{\pi}{4} - \frac{1}{4} \theta \right)$$

$$r(0) = \frac{1}{4} CV$$

$$r(\pi) = CV$$

$$r(0) + r(\pi) = \frac{5}{4} CV = \frac{2V}{\Omega}$$

$$c = 8/5\Omega$$

$$\dot{\theta} = \frac{5\Omega}{8} \cos^{-3} \left(\frac{\pi}{4} - \frac{1}{4} \theta \right)$$

$$T_2 = \int_0^{\pi} \frac{8}{5\Omega} \cos^3 \frac{\pi - \theta}{4} d\theta$$

$$= 3.76/\Omega$$

IV. Stabilization

This chapter will formulate requirements for stabilizing aircraft motion when the aircraft is guided by azimuth and heading "reference functions". The analysis will deal with the case in which the schedule calls for azimuth progress at a constant rate, the reference paths being circles centered at the origin. It will be assumed that a control system stabilized for this basic case would also serve for other reference paths such as eccentric circles and spirals, provided the difference from concentric circles is not great; i.e. for eccentric circles that the center is fairly near the origin, and for equiangular spirals that the constant angle β is relatively small.

Section 9. Linear Approximation Procedures

The stability of non linear dynamic systems of the type to be dealt with here can be determined by analysis based on the first order terms of power series expansions of the differential equations in terms of their dependent variables. The process will be termed "linearizing" the system. Simple rules for linearization will be given in Section 9b.

An "increment function" will be defined as the deviation of a quantity from its "reference function", and will be denoted by the symbol δ before the variable, e.g., $\delta\theta(t) = \theta(t) - \theta_1(t)$, where $\theta(t)$ is the actual function, and $\theta_1(t)$ is the reference function. Derivatives of $\delta\theta$ will be written $\delta\dot{\theta}$, $\delta\ddot{\theta}$, etc.

"Linearized" variables may appear in the system equations in two forms: (1) as the whole of the functions or, (2) as increment functions. The equations can always be converted from either form to the other.

Section 9a. Basic linear approximations

The reference functions for circles centered at the origin will be needed:

$$\left. \begin{aligned} \theta_1 &= \Omega t \\ \beta_1 &= 0 \\ r_1 &= v/\Omega \end{aligned} \right\} \dots(9.1)$$

Reference functions for other variables can be derived from (9.1), in particular

$$\begin{aligned} \phi = \beta - \theta \text{ (1.1) gives: } & \psi_1 = -\Omega t \\ \text{and } \frac{V\dot{\phi}}{R} \approx \phi \text{ (2.2) gives: } & \phi_1 = -\frac{V\Omega}{g} \dots(9.2) \\ & \dot{\phi}_1 = 0 \end{aligned}$$

The lateral equation of motion $\frac{V\dot{\phi}}{R} \approx \tan \phi$ (2.2) is approximated by ^{the} linear equation $\frac{V\dot{\phi}}{R} = \phi$ (9.3)

At $\phi = 15^\circ$ the difference between $\tan \phi$ and ϕ is only 3%, while at 30° , the difference is 9%. Since bank angle is to be limited to 30° , the approximation is quite good throughout the range.

(The power series for $\tan \phi$ is $\tan \phi = \phi + \frac{\phi^3}{3} + \frac{2\phi^5}{15} + \dots$, thus the deviation from linearity is third order.)

The linear approximation for $\dot{r} = V \sin \beta$ is:

$$\dot{r} = v\beta \dots(9.4)$$

At $\beta = 30^\circ$ the error in replacing $\sin \beta$ by β is 5%, and at $\beta = 45^\circ$ it is 11%. Again the error is a third order effect.

For $r\dot{\theta} = V \cos \beta$, (2.4), we can write:

$$r = \frac{V \cos \beta}{\dot{\theta}} = \frac{V \cos \beta}{\Omega + \delta\dot{\theta}} = \frac{V \cos \beta}{\Omega (1 + \delta\dot{\theta}/\Omega)} \dots\dots(9.5)$$

With β small, $\cos \beta \approx 1$; and with $\delta\dot{\theta}/\Omega$ small, $\frac{1}{1 + \delta\dot{\theta}/\Omega} \approx 1 - \delta\dot{\theta}/\Omega$,

thus the linear approximation for (9.5) is:

$$r \approx \frac{V}{\Omega} \left(1 - \frac{\delta\dot{\theta}}{\Omega} \right) \dots\dots(9.6)$$

$$\text{or } r \approx \frac{V}{\Omega} \left(2 - \frac{\dot{\theta}}{\Omega} \right) \quad (\text{replacing } \delta\dot{\theta} \text{ by } \dot{\theta} - \Omega)$$

The approximations in this case require dropping second and higher degree terms of the two power series $\cos \beta = 1 - \frac{\beta^2}{2} + \dots$ and

$$\frac{1}{1 + \delta\dot{\theta}/\Omega} = 1 - \delta\dot{\theta}/\Omega + (\delta\dot{\theta}/\Omega)^2 + \dots, \text{ thus there are two second}$$

order errors in the linearized equation. However, the second order

terms tend to cancel each other out, the product of the two power series being $\frac{\cos \beta}{1 + \delta\dot{\theta}/\Omega} = 1 - \frac{\delta\dot{\theta}}{\Omega} + \left[\left(\frac{\delta\dot{\theta}}{\Omega} \right)^2 - \frac{\beta^2}{2} \right] + \text{higher order}$

terms. As a result, when both β and $\frac{\dot{\theta}}{\Omega}$ deviate from their reference values (0 and 1 respectively), the linear approximation may be

very good, e.g. at $\beta = 30^\circ$ and $\dot{\theta} = \frac{2}{3}\Omega$ the difference between

(9.5) and its linear approximation, (9.6), is 2%. The situation is

poorer when either β or $\dot{\theta}$ alone deviates from the reference value,

for example, when $\dot{\theta} = \Omega$ (no deviation) but $\beta = 30^\circ$, then (9.5) and

(9.6) differ by 15%.

Differentiating (9.6) and equating to (9.4) eliminates r , giving the "linearized" relation between θ and β :

$$\beta = -\frac{\ddot{\theta}}{\Omega^2} \dots\dots(9.7)$$

** It should be noted that the symbol δ does not imply that an approximation has been made. In equation (9.5) $\delta\dot{\theta}$ represents the function $(\dot{\theta} - \Omega)$ without approximation.

This is the linearized equivalent of (2.5) and will be important in formulating stabilization systems. The linearization errors in this case can be considerably larger than those estimated above, and may have an appreciable effect on solutions of the control system equations in cases in which schedule deviations are fairly large. However, the formulation of stabilization systems will be based on small deviations. Subsequent examination of the effect of non-linearity at the larger deviations may show some modification of the feedback constants to be desirable. Section 17 will examine the effect of non-linearity somewhat further.

Section 9b. Formal linearization rules.

The following procedure will facilitate the analysis by providing a simple routine for "linearization". The procedure forms the first order terms which would appear if all terms in the equation were replaced by power series in the dependent variables.

Given an equation which is satisfied by the reference functions,

- (1) Write down the total differential of the equation, each term being considered as a function of the dependent variables. Use the symbol " δ " in front of the differentials instead of " d ". In setting down the total differential the derivatives of a dependent variable are to be treated as separate variables. If time appears explicitly it is to be treated as a constant.

- (2) Insert the reference functions for each dependent variable.

The result is the linearized equation in terms of increment functions.

Example: $\dot{r}^2 + r^2 \dot{\theta}^2 + v^2$ (V = constant)

reference functions, $r_1 = v/\Omega$
 $\dot{r}_1 = 0$
 $\dot{\theta}_1 = \Omega$

Total differential: $2\dot{r} \delta\dot{r} + 2\dot{\theta}^2 r \delta r + 2r^2 \dot{\theta} \delta\dot{\theta} = 0$

insert reference functions: $\Omega^2 \frac{v}{\Omega} \delta r + \left(\frac{v}{\Omega}\right)^2 \Omega \delta\dot{\theta} = 0$
 $\delta r = -\frac{v}{\Omega^2} \delta\dot{\theta}$ (9.8)

Since $\delta r = r - v/\Omega$, the result (9.8) is the same as (9.6)

An additional convenient rule is that after finding the linearized equation, it can be differentiated in normal fashion with respect to time, e.g. $\delta\dot{r} = -\frac{v}{\Omega^2} \delta\ddot{\theta}$. (In this rule if time appears explicitly it is no longer to be treated as a constant.) The reason the differentiation rule holds is that when the terms in the original equation are expanded in power series, differentiation of the series term by term is valid, and the first order terms remain first order after differentiation, while higher order terms remain higher order.

Section 9c. Linearized incremental relations

The linearized equations between increment functions which will be needed most frequently are tabulated below for later reference. The equations can be obtained either by algebraic

manipulation of the linear approximations given in Section 9a, viz. replace θ by $\Omega t + \delta\theta$, r by $\frac{v}{\Omega} + \delta r$, etc., or by the technique of Section 9b using the "reference functions" given by Eq. (9.1) and (9.2).

An exception to the use of the symbol δ will be made for the variable β . Since $\beta_1 = 0$, the increment function is the same as the whole function, and the δ will be omitted.

$$\delta r = -\frac{v}{\Omega^2} \delta \dot{\theta} \quad \dots(9.9)$$

$$\delta \dot{r} = v \beta \quad \dots(9.10)$$

$$\beta = -\frac{d\dot{\theta}}{\Omega^2} \quad \dots(9.11)$$

$$\beta = \delta\theta + \delta\psi \quad \dots(9.12)$$

$$\frac{v}{\Omega} \delta\dot{\psi} = \delta\phi \quad \dots(9.13)$$

$$\delta\psi = -\frac{d\dot{\theta}}{\Omega^2} - \delta\theta \quad \dots(9.14)$$

 Section 10. Dynamic System Assumptions

In the previous chapter the dynamic equations of aircraft motion in a "coordinated turn" served only to characterize the geometric features of azimuth progress control, in particular to determine "reference paths" which the aircraft would follow if it were always exactly on schedule. Equations of motion which specify the control forces on the aircraft must now be set up in order to study actual paths under various initial conditions and disturbances.

The analysis deals with a "closed loop" mechanical system in which control forces on the aircraft are determined by positions

of aircraft control surfaces which in turn are determined by feedback data. Figure 1 shows the system schematically.

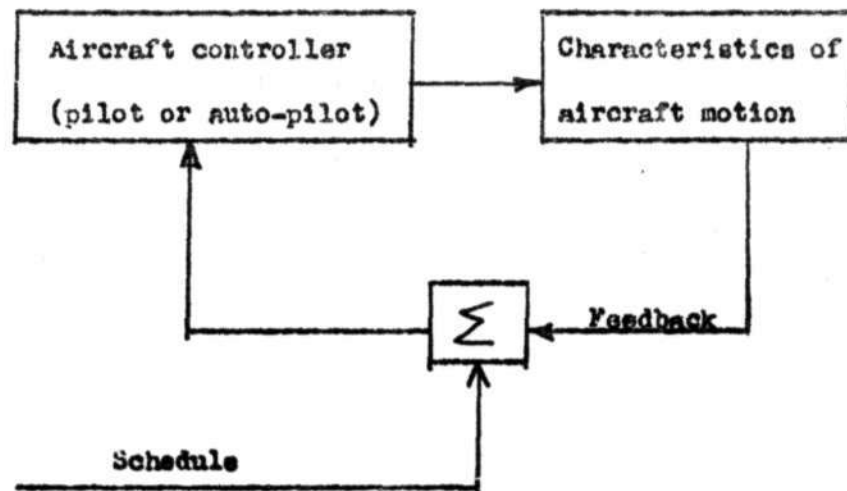

Figure 1. Schematic Control System.

The general approach to dynamic description of the three schematic parts of the system will be as follows:

- (a) Aircraft controller. This schematic section represents a human pilot or an automatic control device and mechanical or servo system linkage from the cockpit to the control surfaces of the aircraft. With a human pilot the "zero-reader" method might be used to indicate stabilization instructions. A description of the dynamic characteristics of a human or automatic pilot and of the control linkage would be very complex. Fortunately it is not

necessary to use detailed characteristics. It can be assumed that the response of the internal components is fast compared with that of the aircraft as a whole. For lateral control of aircraft motion the position of aircraft control surfaces establishes a rate of roll with negligible lag; therefore the internal dynamics will be taken care of simply by assuming that any desired rate of roll can be established without lag.

- (b) Aircraft motion. The linearized dynamic relations given in Section 3 will serve as the dynamic description of this part of the system.
- (c) Feedback. This section of the system represents measurement of aircraft position, subtraction of reference function values from measured values to obtain deviation data, and formation of a linear combination of deviations of several variables to serve as input to the aircraft controller. The output of the feedback section will be defined as the "stabilization function". It is a linear combination of "increment functions".

The dynamic characteristics of the parts of the system which are represented schematically by "aircraft controller" and "characteristics of aircraft motion" are fixed by paragraphs (a) and (b) above. There remains the problem of formulating feedback

systems. A basic system will be set up in the next section, and other possible methods will be discussed in Sections 12 and 13.

Section 11. Basic Control System.

In the stabilization system to be formulated in this section feedback will be represented by a "stabilization function", $\epsilon = c_1 \int \theta + c_2 \dot{\theta} + c_3 \beta + c_4 \dot{\beta}$, that is, by a weighted sum of deviations of azimuth and heading, and their derivatives from schedule. This may be considered to be a basic form of the desired control system since only the quantities to be controlled and their derivatives are fed back. More indirect feedback systems, using radius and/or bank angle data, will be considered in Section 12. The system given in this section will be used for study of aircraft paths in Chapters V and VI.

The reason the stabilization function, ϵ , takes the above form will appear in Section 11a, and selection of numerical values for the quantities c_1 to c_4 in Section 11b.

Section 11a. Differential equation and transfer functions of the system.

Using the above "stabilization function" and the assumptions of Section 10, the control system may be represented schematically as in Figure 2. The relation $\dot{\phi} = k\epsilon$ represents continuous control of rate of roll on the basis of the weighted sum of deviations from schedule.

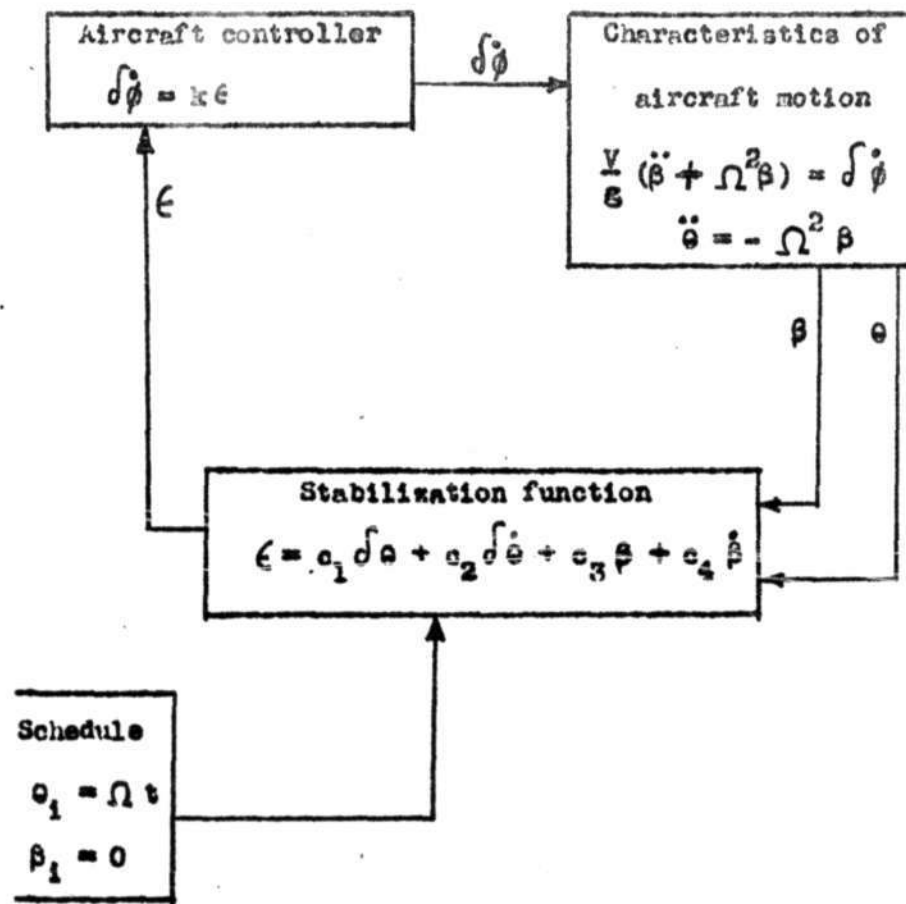

Figure 2.

The system of equations in Figure 2 can be reduced by elimination to the following differential equation in the single dependent variable, $\delta\theta$: (Note that $\ddot{\theta} = \delta\ddot{\theta}$ since $\ddot{\theta}_1 = 0$)

$$\frac{v}{g} \left(-\frac{\delta\ddot{\theta}'''}{\Omega^2} - \delta\ddot{\theta} \right) = k \left[c_1 \delta\theta + c_2 \delta\dot{\theta} - c_3 \frac{\delta\dot{\theta}'}{\Omega^2} - c_4 \frac{\delta\ddot{\theta}'}{\Omega^2} \right] \dots (11.1)$$

The constant k may be absorbed in the feedback parameters c_1 to c_4 , that is, for analytical purposes we take $k = 1$. (The method of

choice of the parameters will automatically take this into account.)

Eq. (11.1) may then be rewritten as:

$$\frac{V}{g\Omega^2} \delta^{\dots\theta} - \frac{c_4}{\Omega^2} \delta^{\dots\theta} + \left(\frac{V}{g} - \frac{c_3}{\Omega^2}\right) \delta^{\dots\theta} + c_2 \delta^{\dots\theta} + c_1 \delta^{\dots\theta} = 0 \quad \dots(11.2)$$

Since this linearized differential equation for azimuth deviation, $\delta\theta$, has constant coefficients, the analysis can proceed in straightforward fashion. The need for including azimuth and heading derivatives in the stabilization function can now be seen: A necessary condition that a linear differential equation with constant coefficients represent a stable system is that the coefficients of the derivatives of all orders up to the highest be non-zero and be of the same sign. The terms in $\delta\dot{\theta}$ and $\delta\ddot{\theta}$ would not be present in (11.2) if the stabilization function had not included the terms $c_2 \delta\dot{\theta}$ and $c_4 \delta\ddot{\theta}$, thus $\dot{\theta}$ and $\ddot{\theta}$ must be fed back to produce stability.

The need for the term $c_3 \beta$ in the stabilization function is not immediately evident from Eq. (11.2) since the coefficient of $\delta\ddot{\theta}$ includes $\frac{V}{g}$ as well as c_3 . However, when numerical values are inserted for V, Ω , and c_1 to c_4 , it can be shown that if c_3 is taken to be zero, the stabilization characteristics of the system are very poor, in fact useless.

Since the differential equation has constant coefficients, the procedures for servomechanism synthesis can be used for study and selection of feedback constants.* However, refined procedures

* "Principles of Servomechanisms," by G. S. Brown and D. P. Campbell. John Wiley and Son, 1948.

"Servomechanisms," vol. 25 of the Radiation Laboratory Series, McGraw Hill.

of servo-system design are not necessary for the present analysis. Figure 3 is a transfer diagram of the system in terms of the complex variable s . It might be noted that the presence of a transfer function of the form $\frac{1}{s^2 + \Omega^2}$ is somewhat surprising since it implies that there is an element in the system which can generate undamped oscillations. The oscillations involved are a characteristic of the coordinate system not of the motion of the aircraft -- if the aircraft flies at uniform speed on an eccentric circle, the azimuth with respect to the origin contains a sinusoidal term.

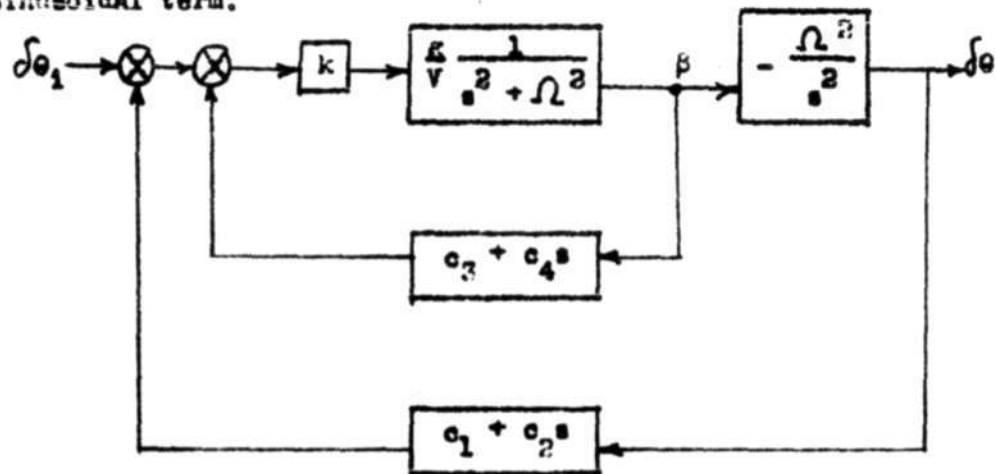

Figure 3. Transfer Function Diagram.

Section 11b. Determination of feedback parameters

For calculation purposes the following system of units has been convenient: angles in radians, distance in miles, and time in minutes. In these units the gravity constant is $g = 21.6 \text{ miles/min.}^2$

Two limiting factors in lateral control were noted in Section 2: Bank angle is to be limited to $30^\circ = .52$ rad., and rate of roll to about $5^\circ/\text{second} = 5.2$ rad./min. The range of rate of roll will be used in determination of the feedback parameters. Subsequent analysis will show that the bank angle remains within its proper range.

The stabilization function $\epsilon = c_1 \delta\theta + c_2 \delta\dot{\theta} + c_3 \beta + c_4 \dot{\beta}$ and the controller action $\delta\ddot{\phi} = k\epsilon$, may be combined as:

$$\delta\ddot{\phi} = c_1 \delta\theta + c_2 \delta\dot{\theta} + c_3 \beta + c_4 \dot{\beta} \quad (k = 1)$$

Since $\ddot{\phi}_1 = 0$ (Eq. (9.2)), and $\ddot{\phi} = \ddot{\phi}_1 + \delta\ddot{\phi}$ we have

$$\ddot{\phi} = c_1 \delta\theta + c_2 \delta\dot{\theta} + c_3 \beta + c_4 \dot{\beta} \quad \dots(11.3)$$

The system will be set up for an aircraft entering an azimuth control sector at $V = 4$ miles/min. (V is taken high enough to represent azimuth control at cruising speed, and to permit subsequent examination of the behavior during deceleration to approach speed.) Assume that the scheduled azimuth progress rate is $\Omega = 1$ radian/minute, and that successive aircraft are to be 1 radian apart.

Assume that the aircraft is scheduled to enter the azimuth control zone at $\theta_1 = 0$ and $t = 0$. Let $\delta\theta_0, \delta\dot{\theta}_0, \beta_0, \dot{\beta}_0$ denote the deviations of azimuth, azimuth rate, heading, and heading rate at $t = 0$. With scheduled separation between aircraft of 1 radian, the initial azimuth deviation, $\delta\theta_0$, must not exceed about ± 0.3 radian. For simplicity assume a case in which $\delta\theta_0 = 0.3$ radians, while $\delta\dot{\theta}_0, \beta_0$, and $\dot{\beta}_0$ are zero. Under

this initial condition the initial rate of roll, $\dot{\phi}_0$, applied for correction of the azimuth error will be assumed to be 3 rad./min. (This leaves leeway for higher rates when $\delta\dot{\theta}_0$, β_0 , and $\dot{\beta}_0$ are not zero.) Inserting the assumed initial conditions in Eq. (11.3) we have: $3 = 0.3 c_1$, $c_1 = 10$.

$c_1 = 10$ is now inserted in equation (11.2) along with $V = 4$, $r = 21.8$, and $\Omega = 1$ giving:

$$\delta\ddot{\theta} - 5.45 c_4 \delta\ddot{\theta} + (1 - 5.45c_3) \delta\ddot{\theta} + 5.45 \delta\dot{\theta} + 54.5 \delta\theta = 0 \quad \dots(11.4)$$

The parameters c_2 , c_3 , and c_4 will now be selected by assuming critical damping, i.e., that (11.4) has 4 equal negative real roots. The equal roots will be denoted by the symbol, λ .

The characteristic polynomial corresponding to (11.4) is

$$s^4 - 5.45 c_4 s^3 + (1 - 5.45c_3) s^2 + 5.45c_2 s + 54.5$$

For critical damping we have:

$$(s - \lambda)^4 = s^4 - 5.45c_4 s^3 + (1 - 5.45c_3) s^2 + 5.45c_2 s + 54.5$$

Equating powers of s gives:

$$\lambda = - 2.72$$

$$c_2 = + 14.8$$

$$c_3 = - 8.0 \quad (\text{The negative signs of } c_3 \text{ and } c_4 \text{ offset the}$$

$$c_4 = - 2.0 \quad \text{negatives in } \beta = - \ddot{\theta}/\Omega^2 \text{ and } \dot{\beta} = - \dot{\ddot{\theta}}/\Omega^2$$

which entered because of the sign conventions of the coordinate system)

A "stabilization function" for the system has thus been determined:

$$\epsilon = 10 \delta\theta + 14.8 \delta\dot{\theta} - 8.0 \beta - 2.0 \dot{\beta} \quad \dots(11.5)$$

and the differential equation in θ for the control system is:

$$\delta\ddot{\theta}'' + 10.9\delta\ddot{\theta}' + 44.5\delta\dot{\theta}' + 80.6\delta\dot{\theta} + 54.5\delta\theta = 0 \quad \dots(11.6)$$

(applicable only when $V = 4, \Omega = 1$)

Eq. (11.6) will provide the starting point in Section 14 for examining the path of an aircraft under azimuth progress control when it enters with a given initial deviation from schedule. It will be shown that the feedback constants chosen here provide error correction characteristics which approximate the geometric possibilities shown in Section 5c. For this reason it does not appear necessary to carry out any more refined servo analysis in a search for optimum constants.

Feedback parameters were determined above by assuming a particular initial condition: $\delta\theta_0 = 0.7, \delta\dot{\theta}_0 = 0, \beta_0 = 0, \dot{\beta}_0 = 0$. As a check that the parameters obtained do not call for too high a rate of roll under other initial conditions, consider the following cases:

(a) Suppose the aircraft does not enter the azimuth control sector at the correct radius. Let the initial error in radius be ± 0.5 mile,

$$\text{By (9.9) } \delta\dot{\theta} = -\frac{\Omega^2}{V} \delta r$$

$$\delta\dot{\theta}_0 = \pm \frac{0.5}{4} = \pm \frac{1}{8} \text{ rad./min. } (\Omega = 1, V = 4)$$

Assume that $\delta\theta_0 = 0, \beta_0 = 0, \dot{\beta}_0 = 0$.

Then $\dot{\beta}_0 = c_2 \delta\dot{\theta}_0 = 14.8 \times \pm \frac{1}{8} = \pm 1.8 \text{ rad./min.}$, which is well within the permissible range for rate of roll.

(b) Suppose there is an initial heading error $\beta_0 = \pm 0.3$ rad., and $\delta\theta_0 = 0, \dot{\delta\theta}_0 = 0, \dot{\beta}_0 = 0$. Then $\dot{\phi}_0 = c_3 \beta_0 = -8.0 \times (\pm 0.3) = \pm 2.4$ rad./min. again within the allowable control range.

(c) Suppose at $t = 0$ that the aircraft has not established a bank angle for the azimuth control sector, but instead is still in straight level flight. Assume $\delta\theta_0 = 0, \dot{\delta\theta}_0 = 0, \beta_0 = 0$. The initial bank angle is $\phi_0 = 0$, and the initial bank angle error (using Eq. (9.2)) is

$$\delta\phi_0 = \phi_0 - \phi_1 = \frac{v\Omega}{g}$$

By (9.13), $\dot{\delta\psi}_0 = \frac{g}{v} \delta\phi_0 = \Omega$

By (9.12), $\dot{\beta}_0 = \dot{\delta\theta}_0 + \dot{\delta\psi}_0 = \Omega = 1$

In this case the initial rate of roll called for by the control system is $\dot{\phi}_0 = c_4 \dot{\beta}_0 = -2$ rad./min., which is again in the allowable range.

Appendix

Section 12. Alternative Stabilization Systems.

In the preceding section a control system was set up in the form which will be used for analysis of aircraft paths in Chapters I and VI. It will be shown below that there are other possible methods of stabilization. The problems involved in evaluation and comparison of the various possibilities will be

indicated, but it would take a large amount of detailed analysis for a thorough study.

Consider Figure 2 with a stabilization function denoted by ϵ , but otherwise unspecified. The relations in the figure can be combined in the form:

$$-\frac{V}{\epsilon} \left(\frac{d^3 \delta \theta}{\Omega^2} + \delta \ddot{\theta} \right) = \epsilon \quad \text{(as in Section 11, } k \text{ can be absorbed in } \epsilon \text{)} \quad \dots(12.1)$$

This section will examine various stabilization functions, .

Section 12a. Stabilizing elements

The quantities which might be used in the stabilization function will be called "stabilizing elements". A list of such quantities, including those which were used in Section 11, follows in Table I.

The column headed "Formation" shows how the desired "stabilizing element" would be formed by means of instrument measurements in the aircraft. r , θ , ψ , ϕ , and V are measurements, while Ω and t are known references. Differentiation of a measured quantity is indicated by $\frac{d}{dt}$ rather than by a dot over the variable in order to distinguish the fact that differentiation by use of electrical or mechanical devices is involved.

The column headed "Stabilizing effect" gives the linearized relation of the "stabilizing element" to $\delta \theta$ (obtained by use of Equations (9.9) to (9.14)). It should be noted that V has different significance in this column from that in the "Formation" column. In the "Formation" column it represents

introduction of speed measurement as part of the feedback process, while in the "Stabilizing Effect" column, speed appears, not as a measured quantity, but as a parameter of the aircraft motion.

Table I - Stabilizing Elements

<u>Symbol</u>	<u>Formation</u>	<u>Stabilizing Effect</u>
$\delta\theta$	$\theta - \Omega t$	$\delta\theta$
$\delta\dot{\theta}$	$\frac{d\theta}{dt} - \Omega$	$\delta\dot{\theta}$
$\delta\psi$	$\psi + \Omega t$ <u>See Note (1)</u>	$(- \frac{d\dot{\theta}}{\Omega^2} - \delta\theta)$
$\delta\dot{\psi}$	$\frac{d\psi}{dt} + \Omega$	$(- \frac{d\dot{\theta}}{\Omega^2} - \delta\dot{\theta})$
β	$\theta + \psi$	$- \frac{d\dot{\theta}}{\Omega^2}$
$\dot{\beta}$	$\frac{d\theta}{dt} + \frac{d\psi}{dt}$	$- \frac{d\dot{\theta}}{\Omega^2}$
δr <u>See Note(2)</u>	$r - \frac{V}{\Omega}$	$- \frac{V}{\Omega^2} \delta\dot{\theta}$
\dot{r}	$\frac{dr}{dt}$	$- \frac{V}{\Omega^2} \delta\dot{\theta}$
$\delta\phi$	$\phi + \frac{V\Omega}{g}$	$- \frac{V}{g} (\delta\dot{\theta} + \frac{d\dot{\theta}}{\Omega^2})$
η <u>See Note(3)</u>	$\phi + \frac{\Omega^2}{g} r$	$- \frac{V}{g} (2\delta\dot{\theta} + \frac{d\dot{\theta}}{\Omega^2})$

Note (1). The reference function for ψ is $\psi_1 = -\Omega t$ (Eq. (9.2)). Therefore $\delta\psi = \psi - \psi_1 = \psi + \Omega t$

Note (2). Use of δr as part of a stabilization function for azimuth control would not imply that radial stabilization is being introduced, since the reference radius, V/Ω , changes freely with the speed of the aircraft and is not specified by the control system. (A similar remark applies to $\delta\phi$)

Note (3). η is a new symbol to represent the given combination of bank angle and radius. This combination provides a way of using radius and bank angle for stabilization without use of speed.

Section 12b. Significant alternatives

The following four considerations provide a basis for combining several "stabilizing elements" into a "stabilization function".

(1) The stabilization function must account for $\delta\theta$ and its first three derivatives. The reasons for this were given in Section 11 in the two paragraphs which follow Equation (11.2).

(2) The "stabilizing elements" in Table I can be divided into two groups corresponding to even and odd $\delta\theta$ derivatives:

$$\underline{\delta\theta, \delta\ddot{\theta} \text{ group}} - \delta\theta, \delta\dot{\psi}, \beta, \dot{r}$$

$$\underline{\delta\dot{\theta}, \delta\ddot{\theta}' \text{ group}} - \delta\dot{\theta}, \delta\dot{\psi}, \dot{\beta}, \delta r, \delta\theta, \eta$$

The stabilization function might be written $\epsilon = \epsilon_1 + \epsilon_2$, where ϵ_1 consists of elements from the $\delta\theta, \delta\ddot{\theta}$ group, and ϵ_2 of elements from the $\delta\dot{\theta}, \delta\ddot{\theta}'$ group.

(3) The stabilization function should be a linear combination of four elements, two from the $\delta\theta, \delta\ddot{\theta}$ group and two from the $\delta\dot{\theta}, \delta\ddot{\theta}'$ group. There are several combinations of fewer than four elements which meet the initial requirement stated above, that $\delta\theta$ and its first three derivatives be represented, e.g., ^a two element system

$$\epsilon = c_1 \delta\psi + c_2 \eta = c_1 \left(\frac{\delta\ddot{\theta}}{\Omega^2} + \delta\theta \right) + c_2 \left(\frac{2Y}{g} \delta\dot{\theta} + \frac{Y}{g} \frac{\delta\ddot{\theta}'}{\Omega^2} \right) \dots (12.2)$$

Brief study of such systems shows that with only two elements either the system cannot be stabilized or else that the stabilization characteristics would be very poor (long time constants). With three elements the stabilization characteristics are still unsatisfactory.* The best three element system appears to be:

$$\epsilon = c_1 \delta \theta + c_2 \beta + c_3 \eta$$

A preliminary study of the control system characteristics using this function indicated that the system could be stabilized but would be quite inferior to the system of Section 11 in which four stabilizing elements were used.

The difficulty with two and three element systems is that they introduce fixed relations between the coefficients of the $\delta \theta$ derivatives. For example, in Equation (12.2), no matter what values of c_1 and c_2 are chosen, there is a fixed ratio between the coefficients of the $\delta \theta$ and $\delta \dot{\theta}$ terms, and also a fixed ratio between the $\delta \dot{\theta}$ and $\delta \ddot{\theta}$ coefficients. With four stabilizing elements, two from the $\delta \theta$, $\delta \dot{\theta}$ group and two

* Use of Routh's test for stability, and examination of characteristic roots associated with reasonable values for the constants, c_i , was adequate for these preliminary appraisals. For a fourth¹ order differential equation with constant coefficients, $\ddot{\ddot{x}} + a\ddot{x} + b\dot{x} + cx + dx = 0$, Routh's criterion for stability consists of the requirements:

$$\begin{array}{l} a, b, c, d > 0 \\ c^2 - abc + a^2d > 0 \end{array}$$

(See Karman and Biot, "Mathematical Methods in Engineering.")

from the $\delta\dot{\theta}$, $\delta\ddot{\theta}$ group, the system is free of such constraints. Use of more than four stabilizing elements would be redundant.

(4) The "relative heading" β appears only as a matter of convenience in analysis. The only way to obtain β in an aircraft is by measurement of θ and ψ , and use of the relation, $\beta = \theta + \psi$. When β and $\dot{\beta}$ appear in the stabilization function, the terms can be regrouped and expressed in terms of $\delta\psi$ and $\delta\dot{\psi}$:

$$\begin{aligned} \epsilon &= c_1 \delta\theta + c_2 \delta\dot{\theta} + c_3 \beta + c_4 \dot{\beta} \\ &= c_1 (\theta - \Omega t) + c_2 (\dot{\theta} - \Omega) + c_3 (\theta + \psi) + c_4 (\dot{\theta} + \dot{\psi}) \\ &= (c_1 + c_3) (\theta - \Omega t) + (c_2 + c_4) (\dot{\theta} - \Omega) + c_3 (\psi + \Omega t) + c_4 (\dot{\psi} + \Omega) \\ &= c_1' \delta\theta + c_2' \delta\dot{\theta} + c_3 \delta\psi + c_4 \delta\dot{\psi} \end{aligned}$$

The alternatives can now be considered in the following way:

Let $\epsilon = \epsilon_1 + \epsilon_2$ as suggested in item (2) above.

There are really only two alternatives for ϵ_1 :

$\epsilon_1 = c_1 \delta\theta + c_2 \beta$, or $\epsilon_1 = c_1 \delta\theta + c_2 \dot{\theta}$. Any other combination of two terms from the $\delta\theta$, $\delta\ddot{\theta}$ group involves exactly the same measurements as one of these two expressions. For ϵ_2 there are more alternatives - any combination of two elements from the $\delta\dot{\theta}$, $\delta\ddot{\theta}$ group which represents both $\delta\dot{\theta}$ and $\delta\ddot{\theta}$ can be used.

The following three examples will be used as a basis for discussion in Section 12c. In each case the stabilization function, ϵ , and the differential equation in $\delta\theta$ obtained by use of (12.1) is given. For simplicity Ω is assumed equal to 1.

$$\begin{aligned} \text{System (a)} \quad \left\{ \begin{aligned} \epsilon &= a_1 \delta\theta + a_2 \delta\dot{\theta} + a_3 \beta + a_4 \dot{\beta} \\ &= a_1(\theta - t) + a_2\left(\frac{d\theta}{dt} - 1\right) + a_3(\theta + \psi) + a_4\left(\frac{d\theta}{dt} + \frac{d\psi}{dt}\right) \end{aligned} \right. \\ \text{Same as in Sec. 11) } \quad \left\{ \begin{aligned} \frac{V}{g} \delta\theta'''' - a_4 \delta\theta''' + \left(\frac{V}{g} - a_3\right) \delta\theta'' + a_2 \delta\theta' + a_1 \delta\theta &= 0 \quad \dots(12.3) \end{aligned} \right. \end{aligned}$$

$$\begin{aligned} \text{System (b)} \quad \left\{ \begin{aligned} \epsilon &= b_1 \delta\theta + b_2 \delta r + b_3 \beta + b_4 \delta\dot{\psi} \\ &= b_1(\theta - t) + b_2(r - v) + b_3(\theta + \psi) + b_4\left(\frac{d\psi}{dt} + 1\right) \end{aligned} \right. \\ \left\{ \begin{aligned} \frac{V}{g} \delta\theta'''' - b_4 \delta\theta''' + \left(\frac{V}{g} - b_3\right) \delta\theta'' - (b_2 v + b_4) \delta\theta' + b_1 \delta\theta &= 0 \dots(12.4) \end{aligned} \right. \end{aligned}$$

$$\begin{aligned} \text{System (c)} \quad \left\{ \begin{aligned} \epsilon &= c_1 \delta\theta + c_2 \eta + c_3 \beta + c_4 \delta\dot{\psi} \\ &= c_1(\theta - t) + c_2\left(\phi + \frac{x}{g}\right) + c_3(\theta + \psi) + c_4\left(\frac{d\psi}{dt} + 1\right) \end{aligned} \right. \\ \left\{ \begin{aligned} \frac{V}{g} \delta\theta'''' - (c_2 \frac{V}{g} + c_4) \delta\theta''' + \left(\frac{V}{g} - c_3\right) \delta\theta'' - (2c_2 \frac{V}{g} + c_4) \delta\theta' + c_1 \delta\theta &= 0 \\ &\dots(12.5) \end{aligned} \right. \end{aligned}$$

Section 12c. Steps required for further analysis.

Thorough evaluation and comparison of the alternative stabilization systems would require careful analysis of the following factors.

(1) Dependence of stability on speed

It can be seen that V enters as a parameter in different ways in Equations (12.3), (12.4), and (12.5). (Also see Figure 3 which represents example (a) above. In that figure $\frac{1}{V}$ enters as a gain factor in the feed-forward section of the servo system. In transfer function diagrams for examples (b) and (c) V would also enter in the feedback sections, thus giving different stability characteristics.) A detailed analysis of the alternative systems would require determination of the range of speeds over which each system would provide satisfactory characteristics. A preliminary analysis was made of examples (a) and (c). The results indicated that the stability of (c) is more sensitive to speed changes, and that there might be difficulty in finding constants for that system which would be satisfactory over an adequate range of speeds.

The stability characteristics of the various systems can be made independent of speed by using speed measurement as a multiplier in the stabilization function. In example (a) above the stabilization function would become:

$$\epsilon = V(a_1' \delta \theta + a_2' \delta \dot{\theta} + a_3' \beta + a_4' \dot{\beta})$$

(a') substituting this in (12.1) gives:

$$\frac{1}{g} \delta \ddot{\theta} - a_4' \delta \ddot{\theta} + \left(\frac{1}{g} - a_3'\right) \delta \ddot{\theta} + a_2' \delta \dot{\theta} + a_1' \delta \theta = 0$$

Thus the differential equation no longer contains V , and the stability characteristics are nominally the same at all speeds.

The same procedure applies to the other systems except that only part of the stabilization function should be multiplied by V , e.g. in example (c):

$$\epsilon = V(c_1' \delta\theta + c_3' \beta + c_4' \delta\dot{\psi}) + c_2' \eta$$

(c') gives the differential equation:

$$\frac{1}{g} \delta\ddot{\theta} - \left(\frac{c_2'}{g} + c_4'\right) \delta\ddot{\theta} + \left(\frac{1}{g} - c_3'\right) \delta\ddot{\theta} - \left(\frac{2c_1'}{g} + c_4'\right) \delta\dot{\theta} + c_1' \delta\theta = 0$$

This procedure appears to be desirable except for the added complication in the stabilization function. The effect of errors in speed measurement also has to be examined, particularly in cases like (c') where V multiplies only part of the stabilization function.

(2) Measurement errors

Since the stabilization function can make use of different measurements and would weight them differently, the probable errors of each type of measurement should be estimated and their effects on the system studied. The measurements which are most likely to introduce difficulties are V , $\frac{dr}{dt}$, $\frac{d\theta}{dt}$, and $\frac{d\beta}{dt}$ ($\frac{d\beta}{dt}$ because it includes $\frac{d\theta}{dt}$). Each of these quantities must be smoothed out to eliminate irregularities. In the case of r and θ , radio propagation noise must be filtered out before taking their derivatives. Air speed, V , must be smoothed to eliminate the effects of turbulence. The smoothing (or filtering) process is equivalent to introducing delays in transmission of the data to

the system. The effect is to make it more difficult to obtain a stable system.

The three examples, (a), (b), and (c), above provide alternatives with regard to the use of smoothed data. System (a) uses $\frac{d\theta}{dt}$, system (b) uses V , and system (c) contains none of the doubtful quantities.

(3) Effect of wind

The effect of a steady wind on system (a) will be analyzed in Chapter VI. In general wind adds a sinusoidal perturbation term to the expressions for the "stabilizing elements" in terms of $\delta\theta$. For example, δr , which appears in Table I as $-\frac{V}{\Omega^2} \delta\dot{\theta}$ becomes $-\frac{V}{\Omega^2} \delta\dot{\theta} + \frac{w}{\Omega} \cos(\Omega t + \mu)$, where w = wind magnitude and μ = wind direction. The perturbations introduce a small "forced oscillation" into the aircraft motion. The procedure of Chapter VI could be applied to alternative stabilization systems in order to determine which minimizes the effect of wind. (The oscillatory effect of wind on orbital flight is analogous to a parallel displacement effect on straight path stabilization.)

(4) Effect of non-linearity.

It will be shown in Section 17 that the linearized analysis used throughout the thesis is a reasonable approximation but should not be taken as a final evaluation. The effect of non-linearity becomes large enough to make it desirable to follow up the results of analysis by linear approximation with more

exact calculations in which the principal non-linearities of the system are taken into account. The difference between linearized and non-linear calculations found in Section 17 is sufficient to indicate that in comparing alternative stabilization systems study of the non-linear effects might have an appreciable bearing on the evaluation.

Section 17. Further Consideration of a Control System Using Azimuth and Heading Feedback

In this appendix the stabilization system will be fundamentally the same as in Section 11, but the form of presentation will be revised in order to accomplish the following purposes:

- (a) To illustrate the concept discussed at the beginning of Section 3, -- that equipment for azimuth progress control can be considered as one feature of an integrated aircraft guidance equipment system. In the stabilization system described below, azimuth error feedback will be part of the input to an auto-pilot heading control, and the auto-pilot can be considered to be the equipment in use on present day aircraft.
- (b) To show the stabilization system in a form which has the specific features required for azimuth progress control, but which permits introduction

of experimental data or assumptions concerning the aircraft controller and aircraft motion dynamics other than the assumptions given in Section 10.

- (c) To show the relation between representation of the system by differential equations, and Laplace transform (transfer function) diagrams.

In the schematic diagram below (Figure 4) the aircraft heading is assumed to be controlled by an auto-pilot, and azimuth feedback may be considered to be an added facility which changes the heading schedule in the direction which stabilizes azimuth progress.

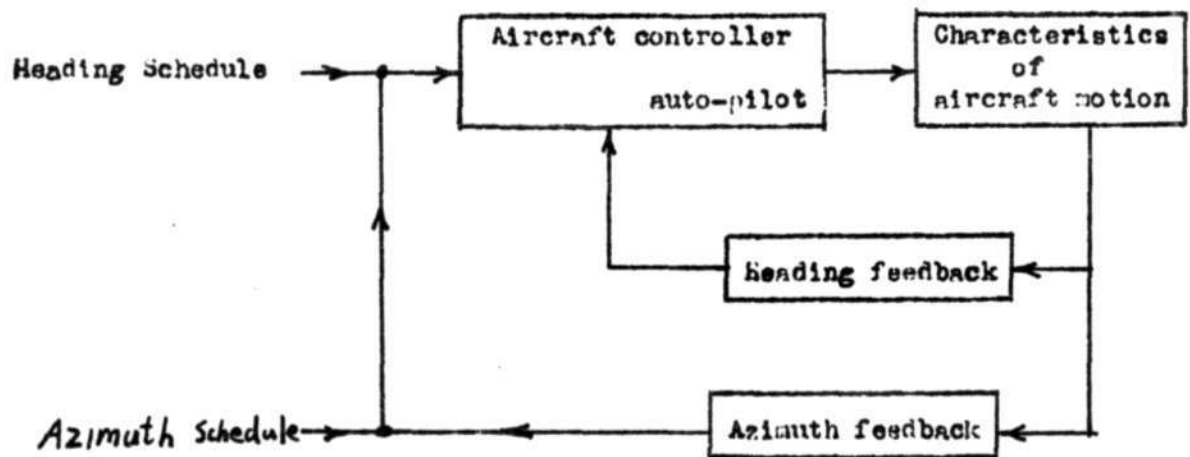

Figure 4. Schematic Control System.

In order to formulate the analysis in a more general way than in Section 11, the system diagram can next be set up as in Figure 5. Heading appears as the variable, ψ (compass heading),

rather than β (relative heading) since an auto-pilot has a compass reference. ψ_1 is the heading reference function, and $\psi_a = \psi_1 - \epsilon_a$ is the input to the auto-pilot, ϵ_a being a weighted sum of deviations in azimuth and azimuth rate. The actual heading, ψ , is subtracted from ψ_a to give the incremental input, ϵ_a , to the auto-pilot. The rectangle containing the notation, $\epsilon_a \rightarrow \epsilon_c$, represents the as yet unspecified dynamic response of the aircraft control surfaces to the mechanical system inside the aircraft. The next rectangle, containing $\epsilon_c \rightarrow \psi$, represents the heading response of the aircraft to its control surfaces. The final block, a relation between heading and azimuth, is Eq. (2.5), with $\psi + \theta$ substituted for β .

Figure 5 has added all of the necessary azimuth relations for azimuth progress control to a heading control system whose dynamic characteristics have not been specified. The presentation provides a framework for making dynamic assumptions other than those of Section 10. In particular, experimental data on heading stabilization could serve as a basis for analysis of azimuth control. The non-linear relation between θ and ψ could be handled by machine computation or could be replaced by the linear approximation:

$$\delta \ddot{\alpha} + \Omega^2 (\delta \theta + \delta \psi) = 0 \quad \dots(13.1)$$

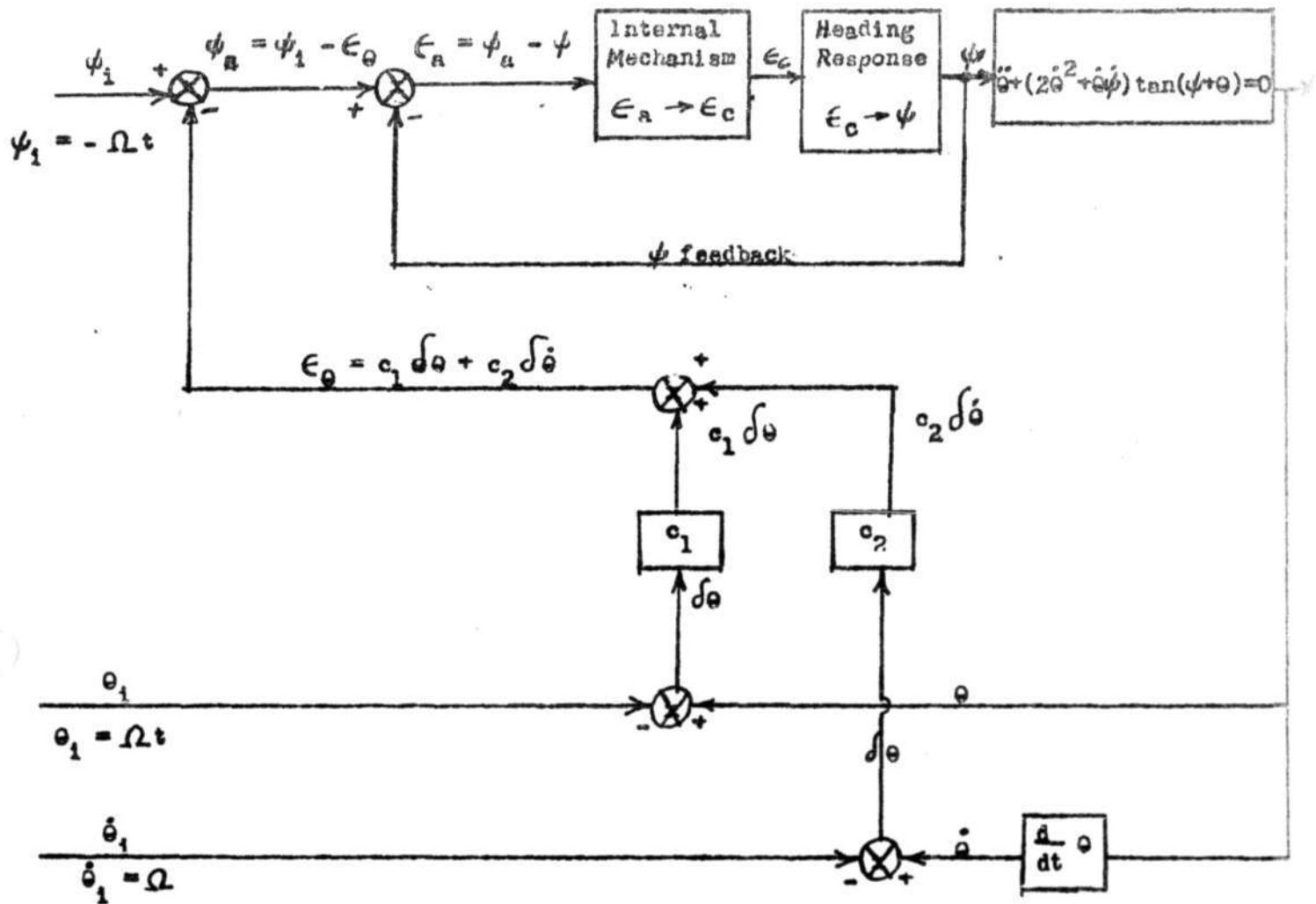

Figure 5.

Figure 6 is a transfer function diagram, equivalent to Figure 5 at small deviations. In this case the unspecified relations, $(\epsilon_a \rightarrow \epsilon_c)$ and $(\epsilon_c \rightarrow \psi)$ appear as unspecified transfer functions G_1 and G_2 .

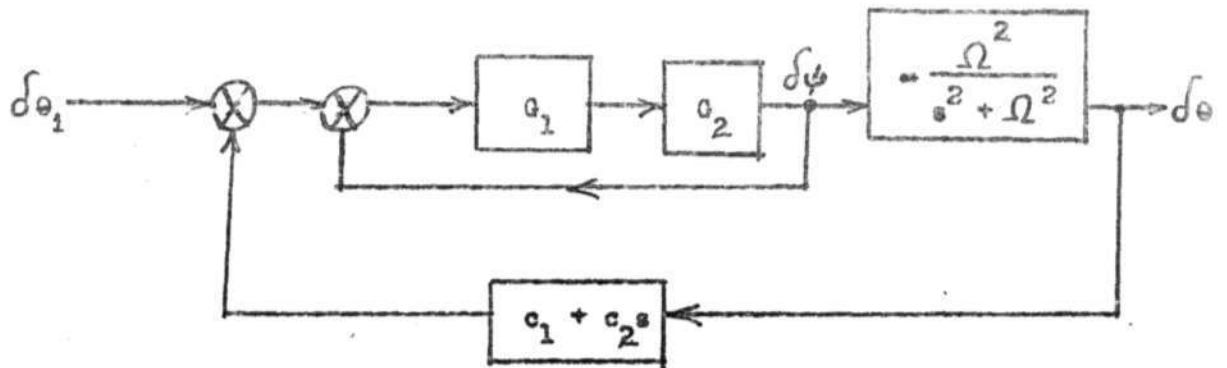

Figure 6. Transfer Function Diagram Equivalent to Figure 5.

The remainder of this section will deal with the relation between the differential equation representation of the system, as in Figure 5, and the transfer function representation, Figure 6. This case will serve as an example of methods used in other parts of the report.

In order to deal with a completely formulated example, the assumptions of Section 10 will be introduced. Lag in the mechanisms inside the aircraft is assumed negligible, and heading rate information is assumed to be obtained by differentiation of the auto-pilot input, ϵ_a . The relation $\epsilon_a \rightarrow \epsilon_c$ in Figure 5 takes the form: $\epsilon_c(t) = c_3 \epsilon_a(t) + c_4 \dot{\epsilon}_a(t)$(13.2)

Assuming coordinated turns and no lag in rate of roll, the pair of equations:

$$\begin{aligned} \dot{\phi} &= k \epsilon_c \\ \frac{V}{g} \dot{\psi} &= \tan \phi \end{aligned} \quad \dots(13.3)$$

describe the heading response, $\epsilon_c \rightarrow \psi$. For analytical purposes let $k = 1$.

The differential equation representation of the system has now been specified. In order to set up the transfer function diagram the differential equations will be expressed in linearized incremental form and then replaced by Laplace transform relations. Each transfer function is the ratio of output to input in the frequency domain.

(17.2) becomes $\epsilon_c(s) = c_3 \epsilon_n(s) + c_4 s \epsilon_n(s)$ in the frequency domain, and we have:

$$c_1 = \frac{\epsilon_c(s)}{\epsilon_n(s)} = c_3 + c_4 s \quad \dots(17.4)$$

(17.3) in linearized incremental form becomes

$$\delta \dot{\theta} = \epsilon_c(t)$$

$$\frac{1}{B} \delta \ddot{\psi} = \delta \dot{\theta}$$

Eliminating $\delta \dot{\theta}$ gives: $\frac{1}{B} \delta \ddot{\psi} = \epsilon_c$

and in transform notation: $\frac{1}{B} s^2 \delta \psi(s) = \epsilon_c(s)$

$$\text{Thus } c_2 = \frac{\delta \psi(s)}{\epsilon_c(s)} = \frac{B}{s^2} \quad \dots(17.5)$$

(17.1) in transform notation is

$$s^2 \delta \theta(s) + \Omega^2 [\delta \theta(s) + \delta \psi(s)] = 0, \text{ which gives}$$

the $\delta \psi \rightarrow \delta \theta$ transfer function already shown in

Figure 6: $\frac{\delta \theta(s)}{\delta \psi(s)} = \frac{-\Omega^2}{s^2 + \Omega^2}$

Finally $\epsilon_\theta = c_1 \delta \theta + c_2 \delta \dot{\theta}$ in Figure 5 becomes

$$\frac{\epsilon_\theta(s)}{\delta \theta(s)} = c_1 + c_2 s$$

After finding the transfer functions, the transfer diagram can be set up as in Figure 6. One must be careful, however, in drawing the interconnections, since in the transfer diagram all functions are in incremental form, while the differential equation diagram contains subtraction points where incremental quantities are formed. The writer has found it desirable to check the equivalence whenever both types of diagram are drawn up. An overall check is provided by using the transfer diagram to find the overall transfer function as a quotient of polynomials in s , and seeing whether the polynomial in the denominator agrees with the characteristic polynomial of the system found by reducing the differential equations to a single linearized equation in $\delta\theta$.

V. Stabilized Flight Paths

The procedure of Section 11 led to the formulation of a control system with specific feedback parameters. This chapter shows the resulting azimuth deviation characteristics and flight paths assuming no wind. The main results are obtained by use of linear approximation. An appendix examines the approximation procedure and shows that it is fairly satisfactory.

Section 14. Correction of Initial Error at Constant Speed

The flight behavior determined by the stabilization system will be shown for the situation when an aircraft enters an azimuth control sector somewhat off schedule. Assume a constant speed of 4 miles/min. and an azimuth rate schedule of $\Omega = 1$ rad./min. (These particular values are used for convenience in computation since they were used in Section 11 in selecting feedback parameters. For more detailed analysis a range of values of V and perhaps also of Ω should be considered. The equations required for more general study will be given in an appendix -- Section 18.) The differential equation in $\delta\theta$ is:

$$\delta\theta'''' + 10.9\delta\theta'''' + 44.5\delta\theta'' + 80.6\delta\theta' + 54.5\delta\theta = 0 \dots (14.1)$$

which has four equal characteristic roots, $\lambda = -2.72$, so that the solution can be written:

$$\delta\theta = e^{\lambda t} p(t) \dots (14.2)$$

where $p(t)$ is a third degree polynomial.

Let there be an initial azimuth error, $\delta\theta_0$, and assume that the other initial deviations are given in the form

$$\delta\dot{\theta}(0) = \beta(0) = \dot{\beta}(0) = 0.$$

Since, by (9.11), $\beta = -\frac{\delta\ddot{\theta}}{\Omega^2}$ and $\dot{\beta} = -\frac{\delta\dddot{\theta}}{\Omega^2}$, the initial conditions for (14.1) are $\delta\theta(0) = \delta\theta_0$, $\delta\dot{\theta}(0) = 0$, $\delta\ddot{\theta}(0) = 0$, and $\delta\dddot{\theta}(0) = 0$.

The solution of (14.1) under these initial conditions is:

$$\delta\theta = \delta\theta_0 e^{\lambda t} \left(1 - \lambda t + \frac{\lambda^2 t^2}{2} - \frac{\lambda^3 t^3}{6} \right) \text{ (radians) } \dots(14.3)$$

$$(\lambda = -2.72, \delta\theta_0 \text{ unspecified})$$

The linear approximations to the other variables are then given by:

$$\begin{array}{l} \text{Radius, } r = 4 - 4\delta\dot{\theta} \text{ (miles)} \\ \text{Heading, } \beta = -\delta\ddot{\theta} \text{ (radians)} \\ \text{Bank angle, } \phi = -.18(1 + \delta\dot{\theta} + \delta\ddot{\theta}) \text{ (radians)} \\ \text{Rate of roll, } \dot{\phi} = -.18(\delta\ddot{\theta} + \delta\dddot{\theta}) \text{ rad./min.} \end{array} \dots(14.4)$$

Let the initial azimuth error be $\delta\theta_0 = -0.3$ radian = -17° .

Figure 1 shows the azimuth deviation as a function of time, and Figure 2 shows the aircraft path. In Figure 2 the points indicated by \bullet are actual positions, and those indicated by \odot are the corresponding scheduled positions. The behavior in heading, bank, and rate of roll can be seen from the following table:

APPROVED FOR PUBLIC RELEASE. CASE 06-1104.

Report R-189

-96-

TABLE I

Time (minutes)	Azimuth error, $\delta\theta$ (Degrees)	Radius, r (miles)	Relative Heading, β (Degrees)	Bank angle, ϕ (Degrees)	Rate of roll, $\dot{\phi}$ Degrees/sec.
0	- 17°	4	0°	- 10°	- 2.9°/sec.
0.25	- 17	3.9	- 11	- 19	+ 0.5
0.5	- 16	3.6	- 16	- 10	+ 0.5
0.75	- 14	3.4	- 11	- 6	+ 0.1
1.0	- 12	3.3	- 3	- 7	- 0.1
1.5	- 7	3.4	+ 6	- 11	- 0.1
2.0	- 3	3.6	+ 6	- 12	0
3.0	- 1	3.9	+ 2	- 11	0

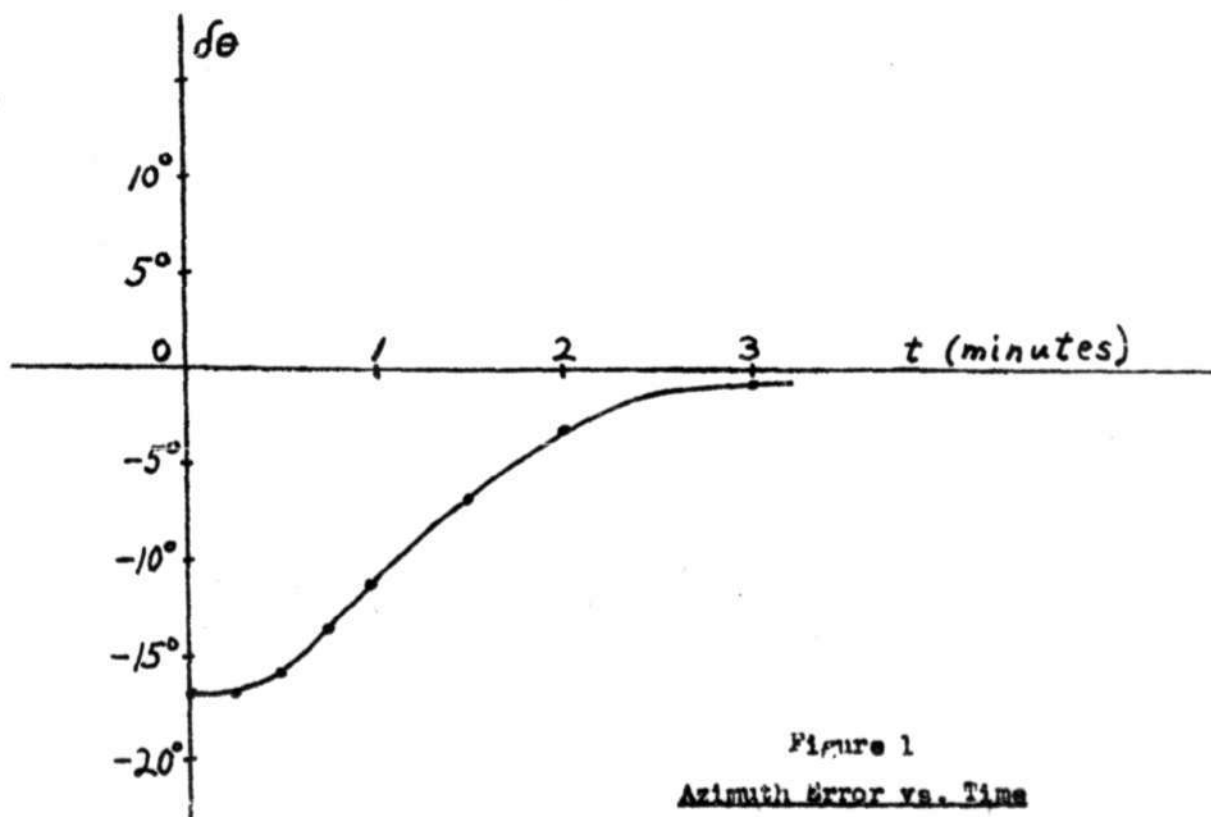

Figure 1
Azimuth Error vs. Time

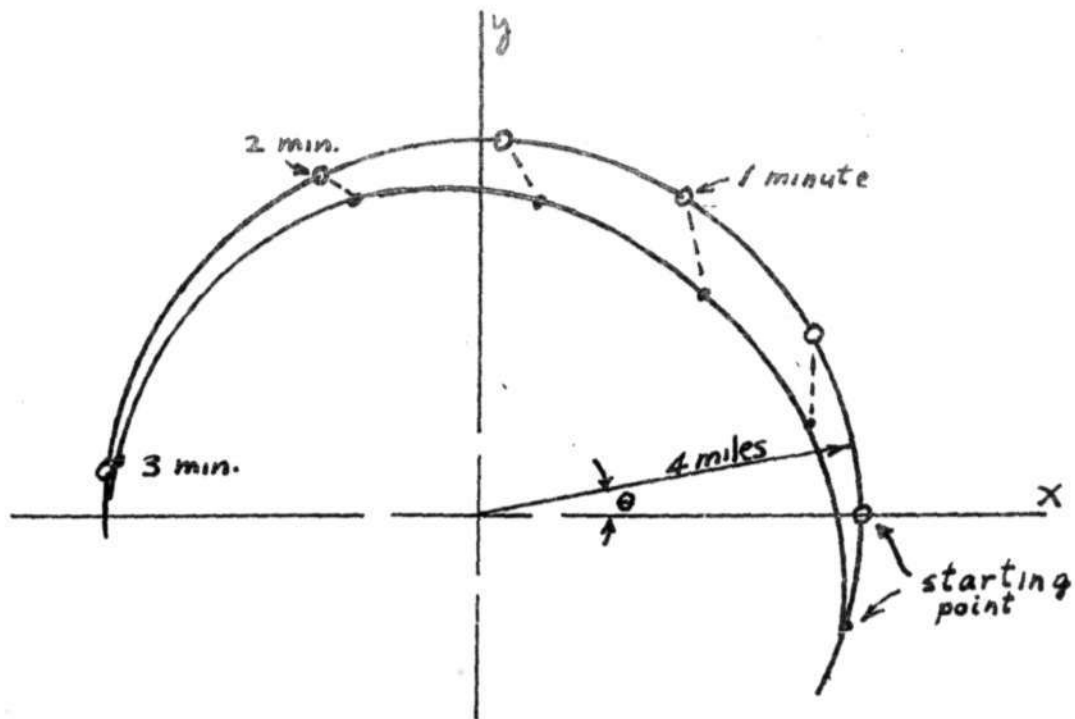

Figure 2. Aircraft Path after Initial -17° Error.

- scheduled position
- actual path

Figure 1 indicates that azimuth progress control would stabilize an initial error rather slowly. In the first $\frac{1}{2}$ minute there is practically no reduction of the error, after 1 minute the error is reduced about 30%, and after two minutes it is down about 80%.

The stabilization characteristics are about as expected when one considers the time-distance-azimuth relations obtainable by path variation on purely geometric grounds (see Section 5c.)

The results of this section should therefore be summarized primarily by saying that the control system set up in Section 11 behaves basically as required for azimuth progress control:

- (a) The system provides closed loop guidance which chooses approximately correct geometric paths for azimuth stabilization.
- (b) Table I shows that the bank angle and rate of roll remain within practical limits

Section 15. Stabilization during Speed Reduction

It was noted in Section 7 that azimuth progress control offers the possibility of flying on an azimuth schedule during deceleration from cruising speed to approach speed, making precise speed control unnecessary. We can now examine the dynamic behavior during deceleration.

It will be assumed that the deceleration is constant. Speed during the deceleration period is described by $v = V + at$, where V = original cruising speed and a = acceleration. The acceleration is assumed to be -1 mile/min.^2 . (This value has been quoted as normal for DC-4 airplanes.) The initial speed, V , is taken as 4 miles/min., and the deceleration is assumed to run for 2 minutes, giving an approach speed of 2 miles/min.

The analysis of the dynamic system when the speed is varying differs somewhat from that for constant speed. The procedure will be described in Section 17b.

Let the initial azimuth deviation be $\delta\theta_0$, and assume $\dot{\delta\theta}(0) = 0$, $\ddot{\delta\theta}(0) = 0$, and $\delta\ddot{\theta}(0) = 0$. Then the azimuth deviation (for $V = 4$, $a = -1$, $\Omega = 1$) is given by:

$$\delta\theta = -0.2 + (\delta\theta_0 + 0.2)e^{\lambda t} \left(1 - \lambda t + \frac{\lambda^2 t^2}{2} - \frac{\lambda^3 t^3}{6} \right) \text{ (radians)}$$

$$(\lambda = -2.72) \quad \dots(15.1)$$

and the radius by:

$$r = 4 - t + \frac{2}{3}(\delta\theta_0 + 0.2)\lambda^4 t^3 \text{ (miles)} \quad \dots(15.2)$$

Figures 3 and 4 show azimuth deviation vs. time and the aircraft path for 3 values of $\delta\theta_0$. These examples indicate the following behavior of the system during deceleration:

- (1) The azimuth control system provides approximately the desired guidance during deceleration, that is the aircraft takes a course which permits it to stay near its azimuth schedule.
- (2) During deceleration the aircraft tends to fall somewhat behind schedule. However, if the aircraft is behind schedule at the start of deceleration, it does not fall further behind.

 Section 16. Simplification of the Analytic Procedure.

It is useful for some purposes to use a simpler but cruder analysis than that in the preceding sections. The procedure to be given here permits preliminary study of the geometric

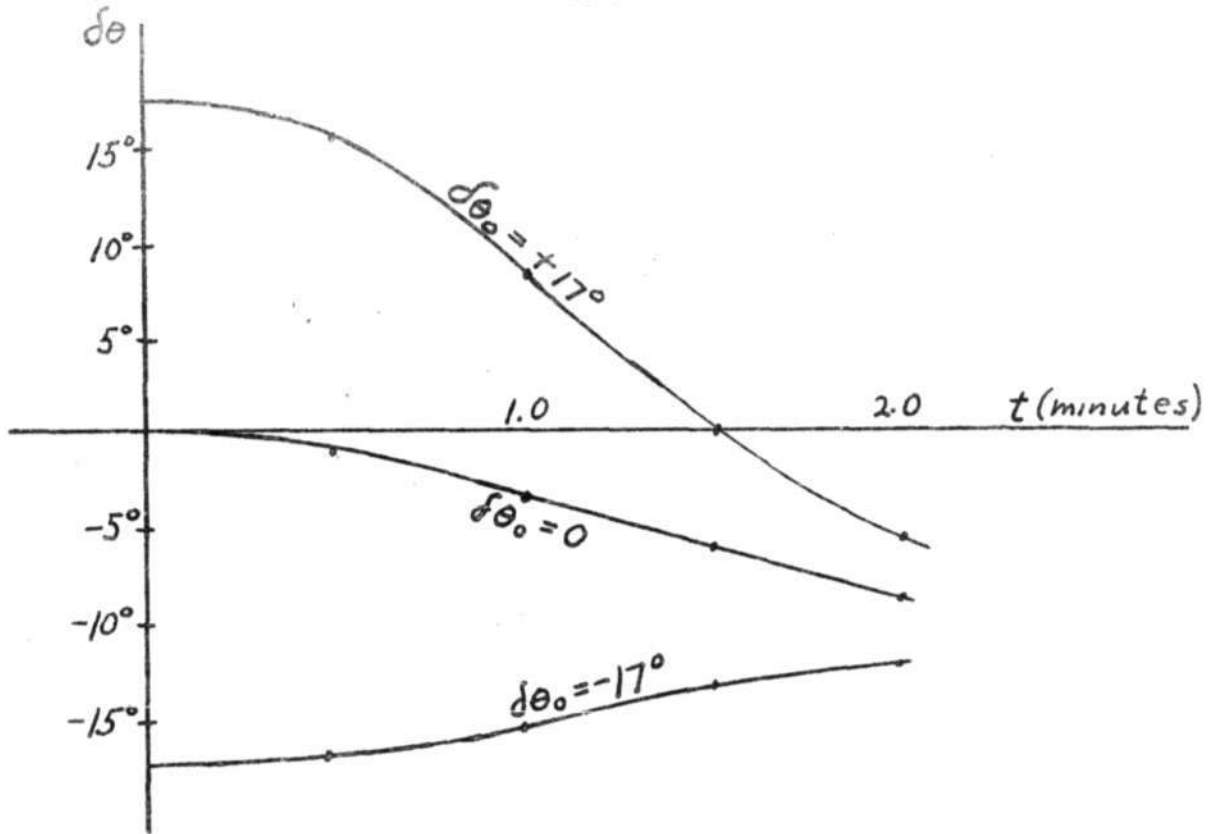

Figure 3. Azimuth Deviation vs. Time under Deceleration

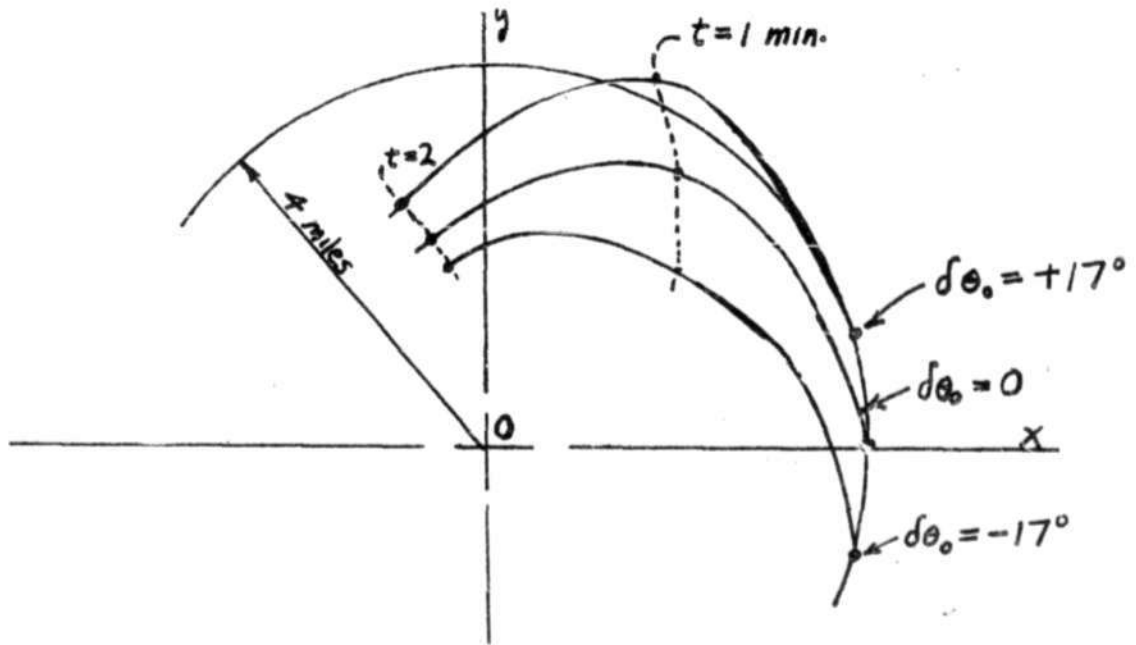

Figure 4. Aircraft Paths under Deceleration.

features of guidance paths on the basis of second order differential equations in place of the fourth order equations which appeared previously. The earlier analysis will be referred to as the "fourth order procedure" and the method described in this section as the "second order procedure".

Section 14 indicated that a fairly long time is required to stabilize after an initial azimuth error. On the other hand, changes in relative heading, β , sufficient to determine the path variations required for azimuth progress control, can be made by the aircraft in a relatively short time. As a result, a simple form of analysis which approximates the earlier procedure can be obtained by neglecting the time lag required to establish a desired heading; in other words, by assuming that relative heading is under instantaneous control. The "stabilization function" required under this assumption is:

$$\beta = c_1 \delta\theta + c_2 \delta\dot{\theta} \quad \dots(16.1)$$

where c_1 and c_2 are constants to be chosen such that paths found under the simplifying assumption are a good approximation for paths determined by the earlier analysis.

The procedure used to select c_1 and c_2 appears in the appendix -- Section 17c. The values obtained are $c_1 = 1$, $c_2 = 2$. Setting $\beta = -\delta\ddot{\theta}/\Omega^2$, and $\Omega = 1$, Equation (16.1) becomes:

$$\delta\ddot{\theta} + 2\delta\dot{\theta} + \delta\theta = 0 \quad \dots(16.2)$$

Thus we deal with a second order equation for $\delta\theta$ instead of the fourth order equation (14.1).

To compare the paths determined by the simplified analysis with those obtained earlier, consider the example used in Section 14. The initial conditions are $\delta\theta(0) = -0.3$ radian, $\delta\dot{\theta}(0) = 0$, and the corresponding solution of (16.2) is:

$$\delta\theta = -0.3 e^{-t}(1+t) \quad (\text{radians}) \quad \dots(16.3)$$

The aircraft path is then given by:

$$\left. \begin{aligned} \theta &= \Omega t + \delta\theta = t - 0.3 e^{-t}(1+t) \\ r &= \frac{v}{\Omega} + \delta r = \frac{v}{\Omega} - \frac{v}{\Omega^2} \delta\dot{\theta} = 4 - 1.2 t e^{-t} \end{aligned} \right\} \dots(16.4)$$

Figure 5 compares the path obtained by use of (16.4) with that obtained in Section 14. It can be seen that the "second order procedure" of this section provides a reasonable approximation to that obtained by the earlier analysis.

It would not have been desirable to proceed directly to the second order procedure without first setting up the fourth order procedure. In the fourth order procedure limits on rate of roll and bank angle were the dynamic considerations which determined the permissible sensitivity of the stabilization system, i.e. determined the feedback constants. On the other hand the second order formulation assumes instantaneous heading control, disregarding the dynamic limitations. Had the second order procedure been set up earlier there would have been no real basis for choice of feedback parameters. The second order procedure is to be thought of only as a way of approximating geometrical features of the fourth order system. It will be used for this purpose in the sections on the effect of wind.

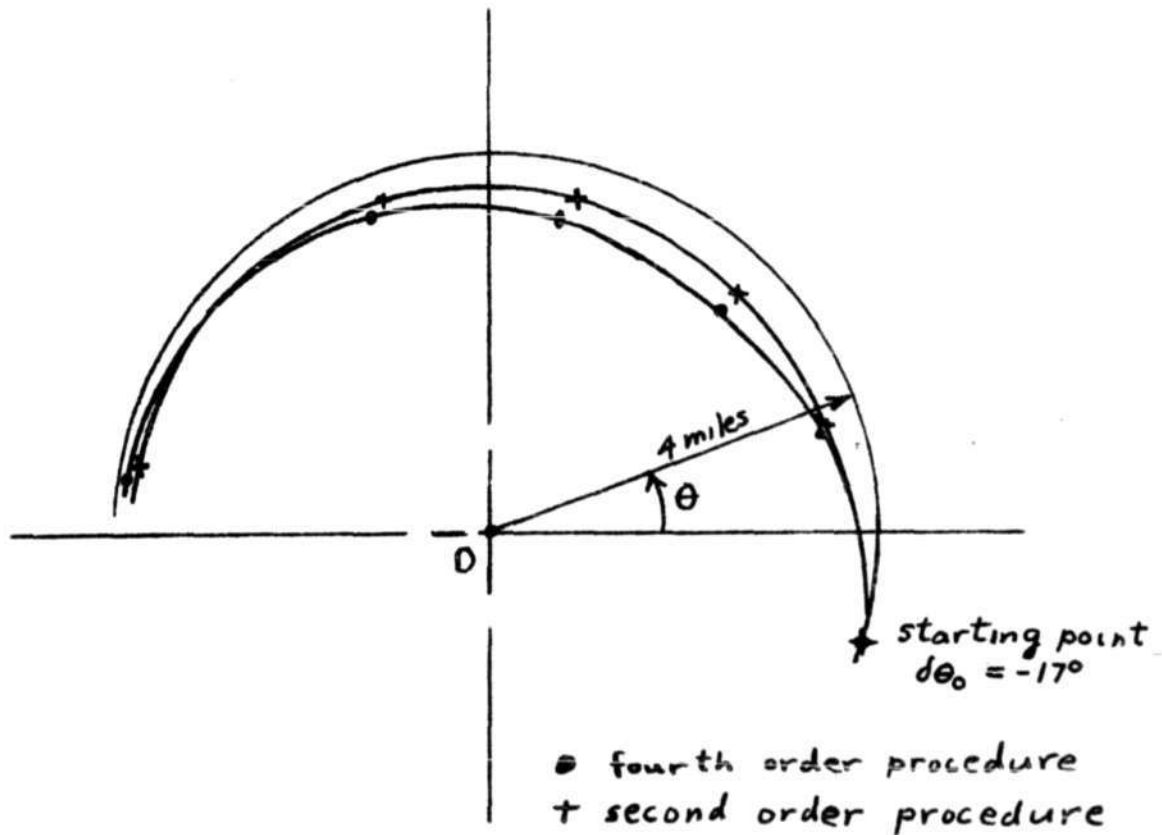

Figure 5. Comparison of Flight Path Obtained by Fourth Order and Second Order Procedures.

AppendixSection 17. Effect of Non-Linearity

It was shown in Section 9a that the elementary relations which serve as a starting point for study of azimuth progress control can be linearized without serious error over the range of the variables which should be covered. This provided preliminary grounds for assuming that linearization would serve not only as the way to formulate a stable system, but also as an adequate approximation procedure for computation of paths. This section will show first that the latter assumption needs further investigation, and will then show by a step-by-step integration of the non-linear equations that the linear approximation is usable.

Section 5c examined path length along two comparable spirals, one outside, and the other inside a semicircular reference path. It was noted that in comparison with the length of the semicircle, the path length increase on the outside spiral was several times greater than the path length reduction on the inside spiral. On the other hand, according to the linearized solution of the stabilization system equations, $\delta\theta = \delta\theta_0 e^{\lambda t} (1 - \lambda t + \frac{\lambda^2 t^2}{2} - \frac{\lambda^3 t^3}{6})$ (Eq. (14.1)), the same length of time is required to stabilize after an initial positive azimuth error as after the corresponding negative error. Thus the question arises whether the linear approximation hides an important geometric feature of the paths.

A second difficulty is that the range over which linear approximation is satisfactory changes under the mathematical

manipulations which lead from the basic relations to the final equations. Consider the equation

$$\ddot{\theta} = -\Omega^2 \beta, \quad \dots(17.1)$$

which was derived in Section 9a from two equations whose linear approximations were good over the desired range. The non-linear form of (17.1) is

$$\text{Eq. (2.5): } \ddot{\theta} = -(\dot{\theta}^2 + \dot{\theta} \dot{\beta}) \tan \beta \quad \dots(17.2)$$

It will be shown that the difference between (17.1) and (17.2) can become large in the range of variables to be covered. The range of the variable β in (17.2) will be examined. Assume that $\dot{\theta} = \Omega$, i.e. that there is no error in azimuth rate, and replace $\tan \beta$ by β , which is a satisfactory approximation over the β range between -45° and $+45^\circ$. Then (17.2) can be written:

$$\ddot{\theta} = -\Omega^2 \left(1 + \frac{\dot{\beta}}{\Omega}\right) \beta \quad \dots(17.3)$$

(17.1) is a reasonable approximation for (17.3) when $\frac{\dot{\beta}}{\Omega}$ is a fraction less than $\frac{1}{2}$. The actual range of values of $\frac{\dot{\beta}}{\Omega}$ can be seen from the lateral force equations:

$$\frac{V}{g} (\dot{\beta} - \dot{\theta}) = \tan \phi \quad \dots(17.4)$$

$$\text{By (17.4), using } \dot{\theta} = \Omega: \frac{\dot{\beta}}{\Omega} = 1 + \frac{g}{V\Omega} \tan \phi \quad \dots(17.5)$$

Let $\Omega = 1$ rad./min. and $V = 4$ miles/min. Then by (17.5), in covering the allowable range of bank angles, ϕ , from -30° to $+30^\circ$, $\frac{\dot{\beta}}{\Omega}$ varies from -2.1 to $+4.1$, whereas only when it remains between say -0.5 and $+0.5$ is (17.1) a good approximation for (17.2) or (17.3). It would stay within the narrower limits only under small deviations from schedule. Thus it appears that

replacing (17.2) by (17.1) is likely to be a weak approximation for computing paths when the deviations from schedule are fairly large.

In view of the above considerations it appeared desirable to check on the validity of the paths found by linear approximation. In order to do so the differential equations for behavior of the system were set up in the same way as for the linearized procedure, except that (17.2) was used in place of (17.1). The equations are given at the end of this section. The resulting non-linear system was integrated step by step from $t = 0$ to $t = 2.0$ minutes, using 0.1 min. intervals. Paths were computed for two initial conditions:

$$(a) \quad \theta(0) = -17^\circ, \quad \dot{\theta}(0) = \beta(0) = \dot{\beta}(0) = 0$$

$$(b) \quad \theta(0) = +17^\circ, \quad \dot{\theta}(0) = \beta(0) = \dot{\beta}(0) = 0$$

Figure 6 compares the paths obtained by step-by-step computation with the corresponding linear approximations (one of which is the example which appeared in Section 14). It can be seen that the linear results provide a fairly satisfactory approximation.

Figure 7 shows the azimuth error vs. time obtained by step-by-step computation for the two initial conditions. The upper curve corresponds to the path outside the reference circle in Figure 6 and the lower curve to the path inside the circle. On the basis of the geometrical discussion of the difference between an outside and an inside path it might have been expected that the upper curve would tend to stabilize more quickly than the lower. Instead the two curves stabilize at about the same rate

with the advantage in favor of the lower curve instead of the upper. Figure 6 shows that the stabilization system tends to produce greater inward than outward deviations from the reference circle, and thus to balance the stabilization characteristics.

In setting up the non-linear equations for the above discussion there were two non-linearities to be considered:

(a) Equation (17.2) above which brings in the characteristics of the coordinate system, (b) the term $\tan \phi$ in the lateral force equation (17.4). The second of these was disregarded, that is, $\tan \phi$ was replaced by ϕ , since it appeared to be only a small effect and would have complicated the computation. The equations of the system can easily be reduced (using the same feedback constants as before) to (17.2) above and (17.6):

$$\frac{Y}{E} (\ddot{\beta} - \ddot{\theta}) = 10(\theta - \Omega t) + 14.8(\dot{\theta} - \Omega) - 8.0 \beta - 2.0 \dot{\beta} \quad \dots(17.6)$$

Assume $V = 4$ and $\Omega = 1$. Let $\dot{\theta} = \omega$, $\ddot{\theta} = \eta$, and $\dot{\beta} = \mu$. Then the equations can be set up in the following form which is convenient for step-by-step computation:

$$\begin{aligned} \text{By (17.2):} \quad \eta &= -(\omega^2 + \omega \mu) \tan \beta \\ \text{By (17.6):} \quad \frac{d\dot{\theta}}{dt} &= \eta + 54.5(\theta - t) + 80.6(\omega - 1) - 43.5 \beta - 10.9 \mu \\ \frac{d\theta}{dt} &= \omega \\ \frac{d\mu}{dt} &= \eta \\ \frac{d\beta}{dt} &= \mu \\ r &= \frac{4 \cos \beta}{\omega} \end{aligned} \quad \dots(17.7)$$

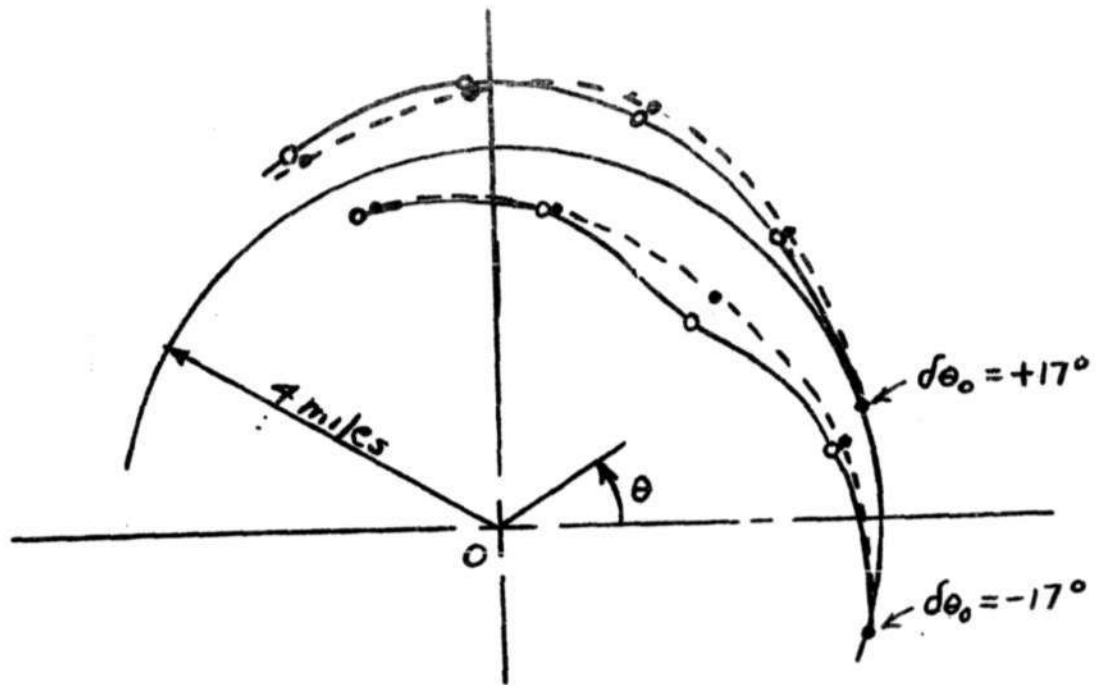

Figure 6. Aircraft Paths.

—○—○—○— Step-by-step computation
 - - ● - - ● - - Linear approximation

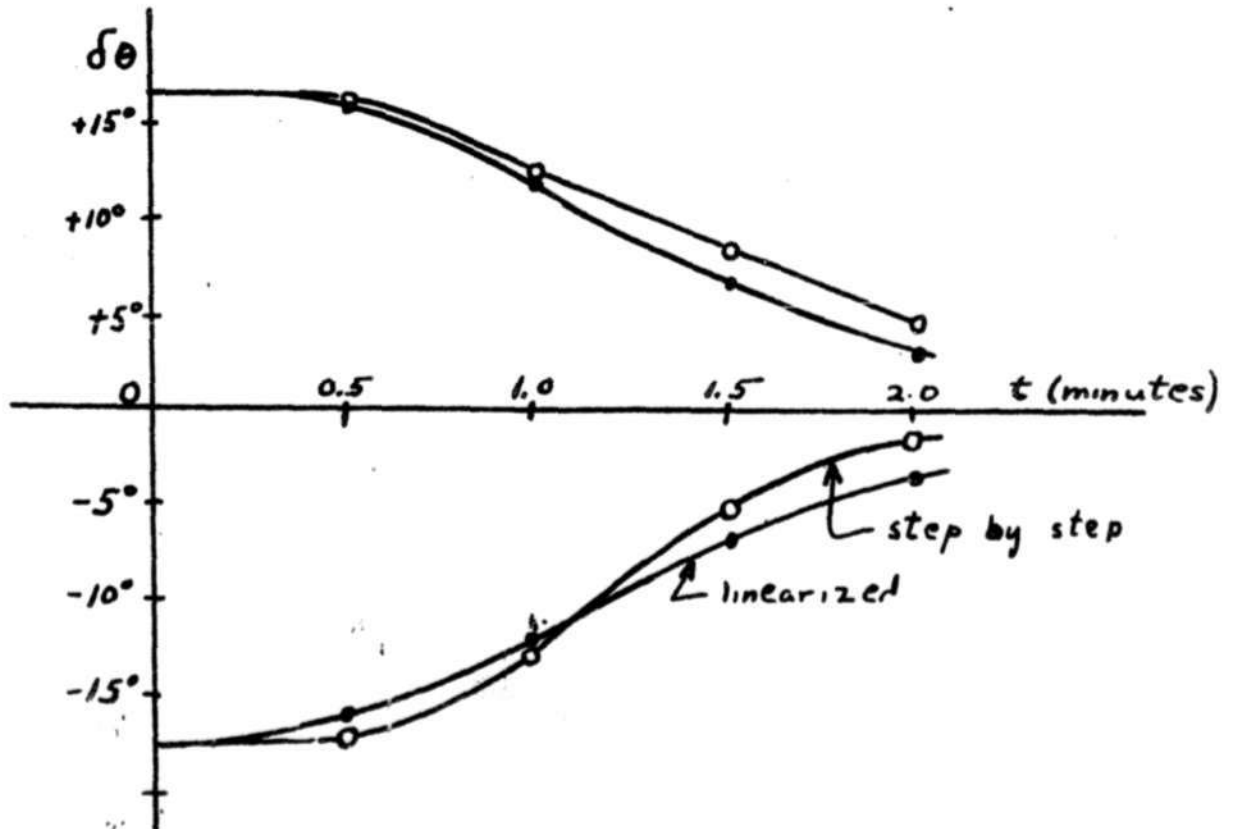

Figure 7. Azimuth Error vs. Time.

Section 18. Supplements to Sections 14, 15, and 16

Section 18a. Constant speed equations (Supplement to Section 14).

Equations for determination of the flight behavior under any initial conditions are given below. For convenience all of the necessary reference functions and linearized incremental relations are collected here. The specific feedback constants chosen in Section 11 are used. V and Ω appear as parameters.

The reference functions are:

$$\begin{aligned} \theta_1 &= \Omega t &) \\ r_1 &= V/\Omega &) \\ \beta_1 &= 0 &) \\ \phi_1 &= -V\Omega/g &) \end{aligned} \quad \dots(18.1)$$

The necessary linearized incremental relations are:

$$\begin{aligned} \delta r &= r - r_1 = -\frac{V}{\Omega^2} \delta \ddot{\theta} &) \\ \beta &= -\delta \dot{\theta} / \Omega^2 &) \\ \delta \phi &= \phi - \phi_1 = -\frac{V}{g} \left(\frac{\delta \ddot{\theta}}{\Omega^2} + \delta \dot{\theta} \right) &) \end{aligned} \quad \dots(18.2)$$

Let the initial conditions be given as position, heading, and bank angle at $t = 0$: r_0 , θ_0 , β_0 , and ϕ_0 . Using (18.1) and (18.2) the initial values of $\delta \theta$, $\delta \dot{\theta}$, $\delta \ddot{\theta}$, and $\delta \dddot{\theta}$ are seen to be:

$$\begin{aligned} \delta \theta_0 &= \theta(0) - \theta_1(0) = \theta_0 &) \\ \delta \dot{\theta}_0 &= -\frac{\Omega^2}{V} [r(0) - r_1(0)] = \underline{\Omega \left(1 - \frac{\Omega r_0}{V} \right)} &) \\ \delta \ddot{\theta}_0 &= -\frac{\Omega^2}{g} \beta_0 &) \\ \delta \dddot{\theta}_0 &= -\Omega^2 \left[\frac{g}{V} \phi(0) - \frac{g}{V} \phi_1(0) + \delta \dot{\theta}(0) \right] = \underline{\Omega^3 \left(\frac{\Omega r_0}{V} - \frac{\phi_0}{V\Omega} - 2 \right)} &) \end{aligned} \quad \dots(18.3)$$

The differential equation for $\delta\theta$ is:

$$\frac{V}{g\Omega^2} \delta\theta'''' + \frac{2.0\Omega}{\Omega^2} \delta\theta'' + \left(\frac{V}{g} + \frac{8.0\Omega}{\Omega^2}\right) \delta\theta'' + 14.8 \delta\theta' + 10\delta\theta = 0 \quad \dots(18.4)$$

After solving (18.4) for $\delta\theta$ under the initial conditions (18.3), the other variables are obtained by use of (18.2).

Section 18b. Deceleration equations (Supplement to Section 15)

In order to analyze the behavior of the system when speed is varying, the dynamic equations will be restated:

$$\begin{aligned} \text{coordinated turn: } & \frac{V}{g} \dot{\psi} = \phi \\ \text{aircraft control: } & \dot{\phi} = k\epsilon \quad (k = 1) \\ \text{stabilization: } & \epsilon = 10\delta\theta + 14.8\delta\theta' - 8.0\beta - 2.0\dot{\beta} \\ & \beta = \theta + \psi \\ & \dot{r} = v \sin \beta \\ & \dot{r}\dot{\theta} = v \cos \beta \end{aligned} \quad \dots(18.5)$$

Equations (18.5) can be linearized by treating the varying speed, v , as a constant reference speed, V , plus an increment function, δv ; $v = V + \delta v$. The reference functions for linearizing the system are the same as for constant speed -- Equations (18.1) -- with the addition of a speed reference, $v_1 = V$. The reduction of the set of equations (18.5) to a single linearized equation in $\delta\theta$ then proceeds as follows:

The linearized incremental forms of $\dot{r} = v \sin \beta$ and $r\dot{\theta} = v \cos \beta$ are:

$$\delta r = v \beta \quad \dots(18.6)$$

$$\delta r = -\frac{v}{\Omega^2} \delta \ddot{\theta} + \frac{\delta \dot{v}}{\Omega} \quad \dots(18.7)$$

Differentiating (18.7) and equating the result to (18.6)

gives:

$$\beta = -\frac{\delta \ddot{\theta}}{\Omega^2} + \frac{\delta \dot{v}}{v\Omega} \quad \dots(18.8)$$

The first four equations in (18.5) reduce by linearization and elimination of ψ , ϵ , and ϕ to:

$$\frac{v}{\epsilon} (\ddot{\beta} - \delta \ddot{\theta} - \frac{\Omega}{\epsilon} \delta \dot{v}) = 10 \delta \theta + 14.8 \delta \dot{\theta} - 8.0 \beta - 2.0 \dot{\beta} \quad \dots(18.9)$$

Eliminating β from (18.9) by use of (18.8) gives the differential equation in $\delta \theta$:

$$\frac{v}{\epsilon} \delta \theta''' + 2 \frac{\delta \ddot{\theta}}{\Omega^2} + \left(\frac{8}{\Omega^2} + \frac{v}{\epsilon}\right) \delta \ddot{\theta} + 14.8 \delta \dot{\theta} + 10 \delta \theta = -\frac{\Omega}{\epsilon} \delta \dot{v} + \frac{v \delta \dot{v}'''}{\epsilon \Omega v} + 2 \frac{\delta \dot{v}}{\Omega v} + \frac{8 \delta \dot{v}}{\Omega v} \quad \dots(18.10)$$

For the calculations in Section 15, $v = 4$, $\Omega = 1$, and $\delta \dot{v} = at = -t$. With these assumptions (18.10) becomes:

$$\delta \theta''' + 10.9 \delta \theta'' + 44.5 \delta \theta' + 14.8 \delta \theta + 10 \delta \theta = -10.7 \quad \dots(18.11)$$

Solutions to (18.11) for any initial conditions are easily obtained since the left hand side has the coefficients which appeared in dealing with constant speed and which correspond to four equal characteristic roots, $\lambda = -2.72$. After solving (18.11) for $\delta \theta$, (18.7) gives δr , and the aircraft path is given by $\theta = t + \delta \theta$ and $r = 4 + \delta r = 4 - t - 4\delta \theta$. Solutions for particular initial conditions were given in Section 15.

In carrying out the above analysis, it appeared at first that the approximation obtained by linearization might be

poor since relatively large speed changes were treated as first degree increments. This meant specifically that terms such as $\int v \dot{\theta} = at \dot{\theta}$, being second degree terms, were dropped. Second approximation equations were therefore set up. The equations obtained were too unwieldy to work with, therefore only the largest second degree terms were kept. The following equation was obtained in place of (18.11):

$$\ddot{\theta}''' + 10.9 \ddot{\theta}'' + 44.5 \ddot{\theta}' + 80.6 \dot{\theta} + 54.5 \theta = -10.7 + \frac{1}{4} \ddot{\theta}''' + 10.9 \dot{\theta} \theta$$

.....(18.12)

The first approximation -- the solution to (18.11) -- was substituted for $\dot{\theta}$ on the right side of (18.12), that is, the solution to the linearized equation was used to approximate the second degree terms. Approximate solutions to (18.12) were thus obtained. The revised results differed very little from the first approximation, indicating that within the range of variations considered the first approximations were satisfactory.

Section 18c. Choice of stabilization constants (Supplement to Section 16)

The following procedure was used to select feedback constants for the "second order procedure" such that the paths obtained would be a reasonable approximation for results obtained by the fourth order method:

Consider the case described in Section 14, where the

fourth order procedure was used under the initial conditions:

$\delta\theta(0) = \delta\theta_0$, $\dot{\delta\theta}(0) = 0$, $\beta(0) = 0$, $\dot{\beta}(0) = 0$. The solution for

$\delta\theta$ is Eq. (14.3):

$$\delta\theta = \delta\theta_0 e^{\lambda t} \left(1 - \lambda t + \frac{\lambda^2 t^2}{2} - \frac{\lambda^3 t^3}{6} \right)$$

$$(\lambda = -2.72)$$

and the corresponding solution for β is:

$$\beta = -\frac{\delta\ddot{\theta}}{\Omega^2} = \delta\theta_0 e^{\lambda t} \left(\frac{\lambda^5 t^3}{6} + \frac{\lambda^4 t^2}{2} \right) \quad \dots(18.13)$$

$$(\Omega = 1)$$

The maximum value of β , found by use of (18.13), is:

$$\beta_{\max.} = .97 \delta\theta_0 \quad \dots(18.14)$$

The stabilization function for the second order procedure is

$$\beta = c_1 \delta\theta + c_2 \dot{\delta\theta} \quad \dots(18.15)$$

and under the initial conditions, $\delta\theta(0) = \delta\theta_0$, $\dot{\delta\theta}(0) = 0$,

(18.15) becomes:

$$\beta(0) = c_1 \theta_0 \quad \dots(18.16)$$

Assuming instantaneous heading control, the initial value of β

for the second order procedure should be about equal to $\beta_{\max.}$

of the fourth order procedure; therefore, comparing (18.14)

and (18.16), c_1 is taken equal to 1. Inserting $\beta = -\delta\ddot{\theta}$ and

$c_1 = 1$ in (18.15) gives

$$\delta\ddot{\theta} + c_2 \dot{\delta\theta} + \delta\theta = 0, \quad \dots(18.17)$$

Choice of $c_2 = 2$ then makes (18.17) represent critical damping.

It has been shown in Section 16 that the resulting second order procedure is a reasonable approximation for the fourth order procedure.

VI. Effect of Wind

The effect of a steady wind will be examined. The wind will be described as a vector of magnitude, w , and compass direction, μ .

As a preliminary to the study of effect of wind on azimuth progress control, the effect on circular flight paths without azimuth control will be shown. The azimuth stabilization system will then be examined from two points of view: (a) determination of azimuth deviations and flight paths when the wind vector is disregarded, (b) provision of revised heading reference functions which take wind into account.

The results for steady winds could be used for preliminary examination of the effect of gusts by treating gusts as steady winds of short duration. However, no computations have been made along this line.

It will be necessary to make use of two coordinate systems: ground coordinates, and a coordinate system which moves with the wind. The latter will be referred to as "air-mass coordinates". Position in air-mass coordinates will be signified by primed symbols: x' , y' , r' , θ' . For convenience we can let the centers of the two coordinate systems coincide at $t = 0$. Airspeed, V , will not be primed, but refers, of course, to air-mass coordinates.

Section 19. Circular Paths, without Azimuth Control.

Consider an aircraft moving at constant airspeed V , and turning at a constant rate, p . Assume there is a steady wind of magnitude, w , and direction, μ . The path is a circle in air-mass coordinates:

$$\begin{aligned} \theta' &= pt &) \\ & &) \\ r' &= V/p &) \end{aligned} \quad \dots(19.1)$$

The path in ground coordinates is obtained by a straightforward transformation of coordinates (see Section 22):

$$\begin{aligned} r &= \frac{V}{p} \sqrt{1 + 2 \frac{w}{V} pt \sin(pt + \mu) + (\frac{w}{V} pt)^2} &) \\ & &) \\ \theta &= \text{arc tan} \left(\frac{\sin pt + \frac{w}{V} pt \cos \mu}{\cos pt + \frac{w}{V} pt \sin \mu} \right) &) \end{aligned} \quad \dots(19.2)$$

Figure 1 shows the ground path for $V = 2$ miles/min., $p = 1$ rad./min., $\mu = \frac{\pi}{2}$ (wind in the direction of the positive x axis), at two values of $\frac{w}{V}$: 0.1 and 0.3.

Secondly, consider an aircraft which moves at constant airspeed, V , over a ground circle of radius, R . In the presence of wind the ground speed varies with angular position, and the azimuth progress rate is not constant. The relation between azimuth and time is given by (see Section 22):

$$t = \frac{R}{V} \frac{1}{1 - \frac{w^2}{V^2}} \left[\frac{w}{V} \sin(\mu + \theta_1) - \frac{w}{V} \sin(\mu + \theta_2) + \int_{\theta_1}^{\theta_2} \sqrt{1 - \frac{w^2}{V^2} \sin^2(\mu + \theta)} d\theta \right] \quad \dots(19.3)$$

where t is the time between the angular positions θ_1 and θ_2 .

(19.3) can be evaluated by use of elliptic integral tables.

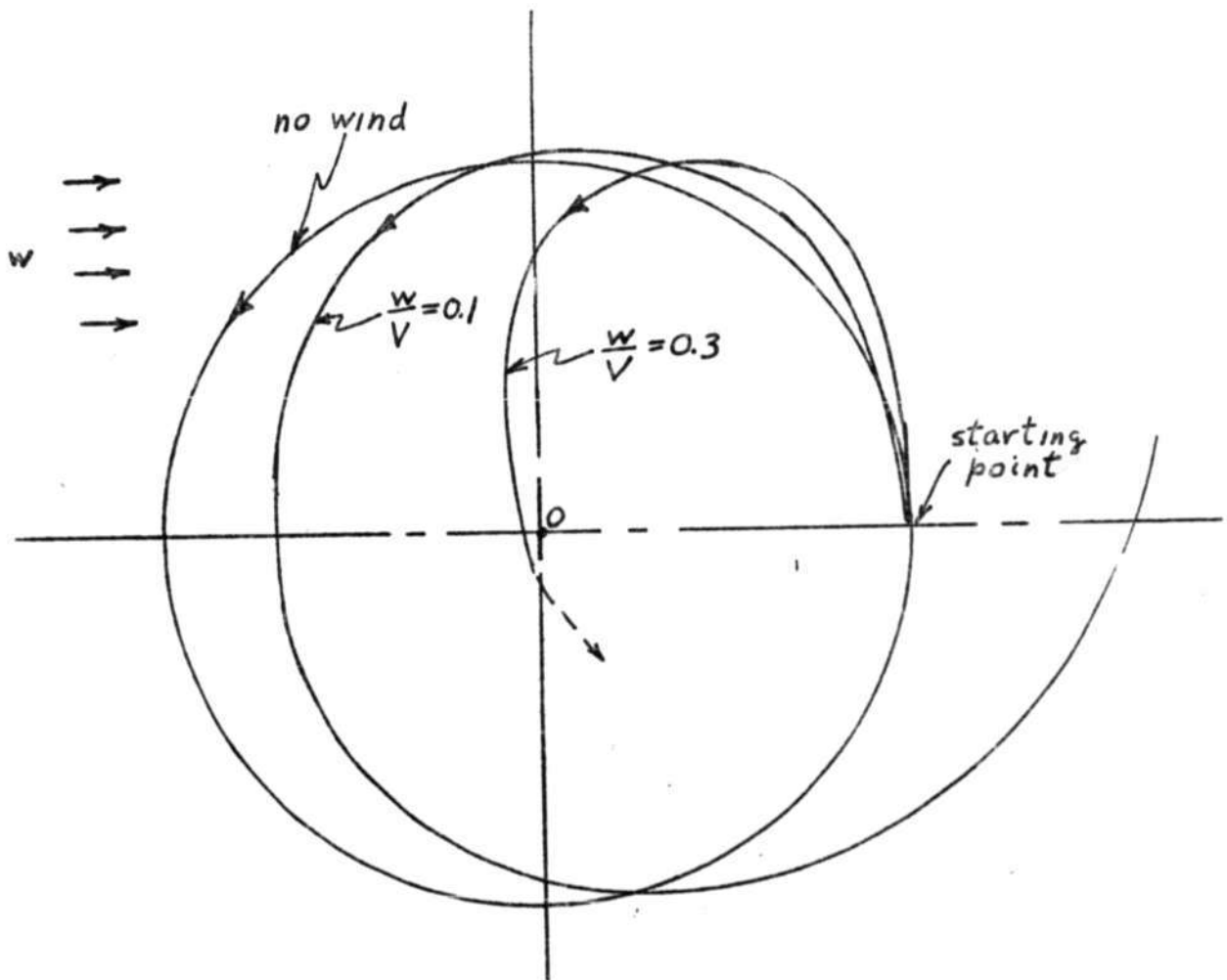

Figure 1. Effect of Wind on Flight Paths
at Constant Rate of Turn

Let $\frac{w}{V} = k$. It is convenient to let w have positive and negative values to indicate opposite wind directions, using a single value of k . The following few values of the complete elliptic integral, $E(k)$, are sufficient to evaluate (19.3) in several cases of interest:

k	0	± 0.1	± 0.2	± 0.3(19.4)
$E(k)$	1.571	1.567	1.555	1.535	

For a flight path as indicated in Figure 2, the time required to traverse 180° with the wind in the direction of the y axis ($\mu = 0$) is given by:

$$t = \frac{2R}{V(1 - k^2)} E(k) \quad \text{.....(19.5)}$$

and for wind in the direction of the x axis by:

$$t = \frac{2R}{V(1 - k^2)} [k + E(k)] \quad \text{.....(19.6)}$$

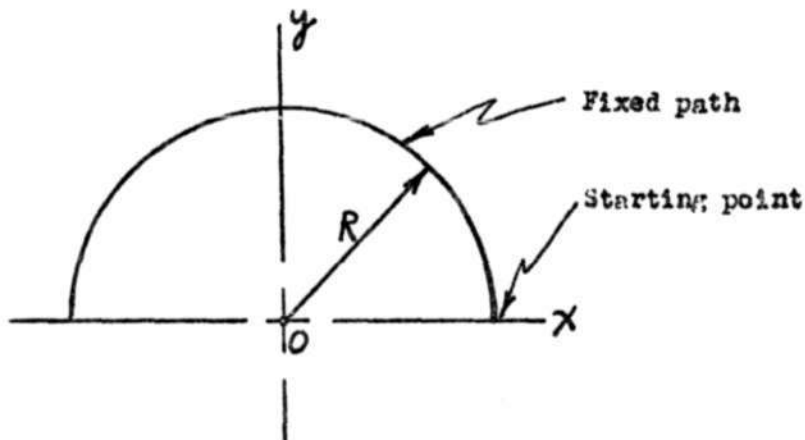

Figure 2.

Let $\frac{R}{V} = 1$, which corresponds to an azimuth rate of 1 radian/min. in the wind free case. Under no wind the time over a 180° sector is 3.14 min. = 188 seconds. The time deviations, δt , caused by wind in the y axis direction, obtained by use of (19.4) and (19.5) are:

$k = \frac{W}{V}$	± 0.1	± 0.2	± 0.3
δt (seconds)	+ 1	+ 6	+ 14

For wind in the x direction the time changes are:

$k = \frac{W}{V}$	+ 0.1	+ 0.2	+ 0.3	- 0.1	- 0.2	- 0.3
δt (seconds)	+ 13	+ 31	+ 54	- 11	- 19	- 25

Equation (19.3) can be evaluated to a close approximation without use of elliptic integrals by series expansion to the second degree in $k = \frac{W}{V}$. (See Section 22.) The result is:

$$\frac{V}{R} t = \left[\theta - k \sin(\mu + \theta) + \frac{3}{4} k^2 \theta + \frac{k^2}{8} \sin 2(\mu + \theta) \right] \Bigg|_{\theta_1}^{\theta_2} \dots (19.7)$$

 Section 20. Azimuth Stabilization.

In the previous section it was possible to work with exact equations, but for analysis of the azimuth stabilization system it is necessary to return to linear approximation.

In order to simplify the analysis the stabilization system will be represented by a second order differential equation, as discussed in Section 16, rather than by a fourth order equation.

The results to be given in this section can be looked at from two points of view:

- (a) Wind disregarded -- azimuth and heading reference functions may be set up on the basis of no wind and left unchanged when wind is present. The analysis to follow then shows the azimuth errors introduced by winds.
- (b) As a wind error effect -- assume that heading adjustments are made to compensate for a measured wind (see the next section). Under wind fluctuations and measurement errors there will be an unknown wind component which cannot be taken into account. The analysis of azimuth errors due to this component is the same as for item (a).

The equations of the system are as follows:

In place of the no-wind relations, $\dot{r} = V \sin \beta$ and $\dot{r}\theta = V \cos \beta$, we have (see Section 22):

$$\begin{aligned} \dot{r} &= V \sin \beta + w \sin(\theta + \mu) \\ \dot{r}\theta &= V \cos \beta + w \cos(\theta + \mu) \end{aligned} \quad \dots(20.1)$$

(β is still the heading of the aircraft axis relative to the radius vector in the ground coordinate system.)

Equations (20.1), when linearized relative to $\theta_1 = \Omega t$, $r_1 = V/\Omega$,

$\beta_1 = 0$, and $w_1 = 0$, become:

$$\delta \dot{r} = V \beta + w \sin(\Omega t + \mu) \quad \dots(20.2)$$

$$\delta \ddot{r} = -\frac{V}{\Omega^2} \delta \ddot{\theta} + \frac{w}{\Omega} \cos(\Omega t + \mu) \quad \dots(20.3)$$

(w like β has zero reference, therefore is written without the symbol δ in the linearized equations)

Differentiation of (20.3) and use of (20.2) gives the linearized relation between β and θ :

$$\beta = -\frac{\delta \ddot{\theta}}{\Omega^2} - \frac{2w}{V} \sin(\Omega t + \mu) \quad \dots(20.4)$$

The stabilization function for the "second order procedure" formulated in Section 16 was $\beta = \delta \theta + 2\delta \dot{\theta}$. Use of (20.4) for β gives the differential equation for $\delta \theta$:

$$\frac{\delta \ddot{\theta}}{\Omega^2} + 2\delta \dot{\theta} + \delta \theta = -\frac{2w}{V} \sin(\Omega t + \mu) \quad \dots(20.5)$$

The solution of (20.5) for $\delta \theta$, followed by use of (20.3) for δr , gives the linear approximation to the aircraft path.

Let $\Omega = 1$ rad./minute. The solution of (20.5) is:

$$\delta \theta = C_1 e^{-t} + C_2 t e^{-t} + \frac{w}{V} \cos(t + \mu) \quad \dots(20.6)$$

where C_1 and C_2 are integration constants.

For illustration let the initial conditions be $\theta(0) = 0$, $r(0) = V$. Then the initial conditions for (20.6) are:

$$\delta \theta(0) = 0$$

$$\delta \dot{\theta}(0) = \frac{w}{V} \cos \mu \quad (\text{using (20.3) with } \delta r = 0)$$

(The non-zero initial condition on $\delta \dot{\theta}$ expresses the fact that if the initial radius is correct for no wind, then the azimuth

rate is in error due to the component of wind speed in the direction of aircraft motion.) With these initial conditions (20.6) becomes:

$$\int \delta \theta = \frac{W}{V} e^{-\Omega t} (t \sin \mu - \cos \mu) + \frac{W}{V} \cos(t + \mu) \quad \dots(20.7)$$

Azimuth deviations given by (20.7) are plotted against time in Figure 3 with $\frac{W}{V} = 0.1$, for several wind directions, μ . Under the linear approximation, curves for $\frac{W}{V}$ other than 0.1 are obtained by proportional multiplication of ordinates. The maximum deviation shown in Figure 3 is $\delta \theta = 6^\circ$. Therefore, an estimate of the maximum error for any wind direction is:

$$\delta \theta = 6 \frac{W/V}{0.1} = 60 \frac{W}{V} \text{ degrees} \quad \dots(20.8)$$

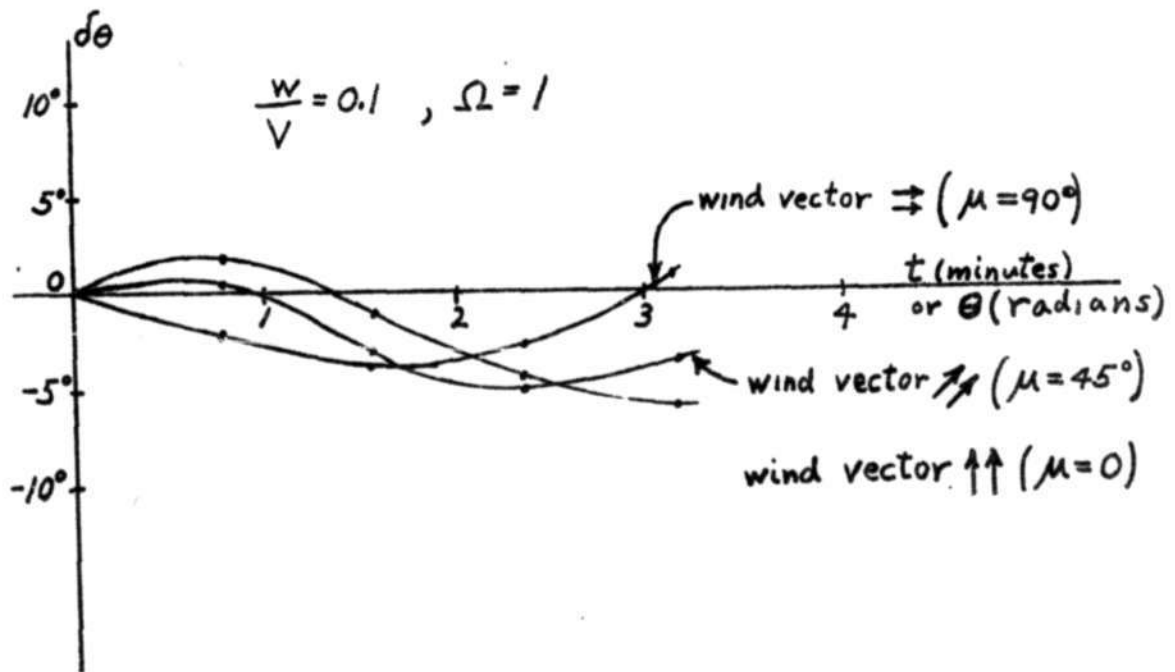

Figure 3. Azimuth Deviation Due to Wind for Several Wind Directions

At fairly high winds the azimuth deviations permitted by the stabilization system can be fairly large. For example, at $w = 40$ miles per hour and $V = 120$ miles per hour, by (20.8) the azimuth deviation due to wind could go up to 20° .

Section 21. Heading Reference Adjustment.

Possibly the azimuth deviations due to wind, shown in the previous section, could be tolerated without modification of azimuth control schedules since the deviations of successive aircraft would be approximately in phase. This would be desirable since it would preserve the simplicity of guidance instructions. On the other hand, more detailed analysis, in conjunction with formulation of an integrated plan for airport approach, may show that adjustments for wind must be made. A procedure for modifying the heading reference function to compensate for wind follows. The objective is to keep the aircraft on a constant azimuth progress schedule, $\theta_1 = \Omega t$.

In this section w and μ will refer to measured values of prevailing wind magnitude and direction rather than to true values. The results of the previous section would still apply to the wind error component.

A preliminary basis for wind compensation will be shown by use of Figure 4. Under no wind let the circle C about the origin be the path of an aircraft which is advancing at azimuth progress rate $\Omega = V/R$. Suppose there were a wind, w , in the

direction of the x axis. It will be shown that if the aircraft follows the path C_1 instead of C the azimuth progress rate remains virtually unchanged. C_1 is a circle of the same radius as C , with center O_1 on the y axis below O , and with $OO_1 = w/\Omega$.

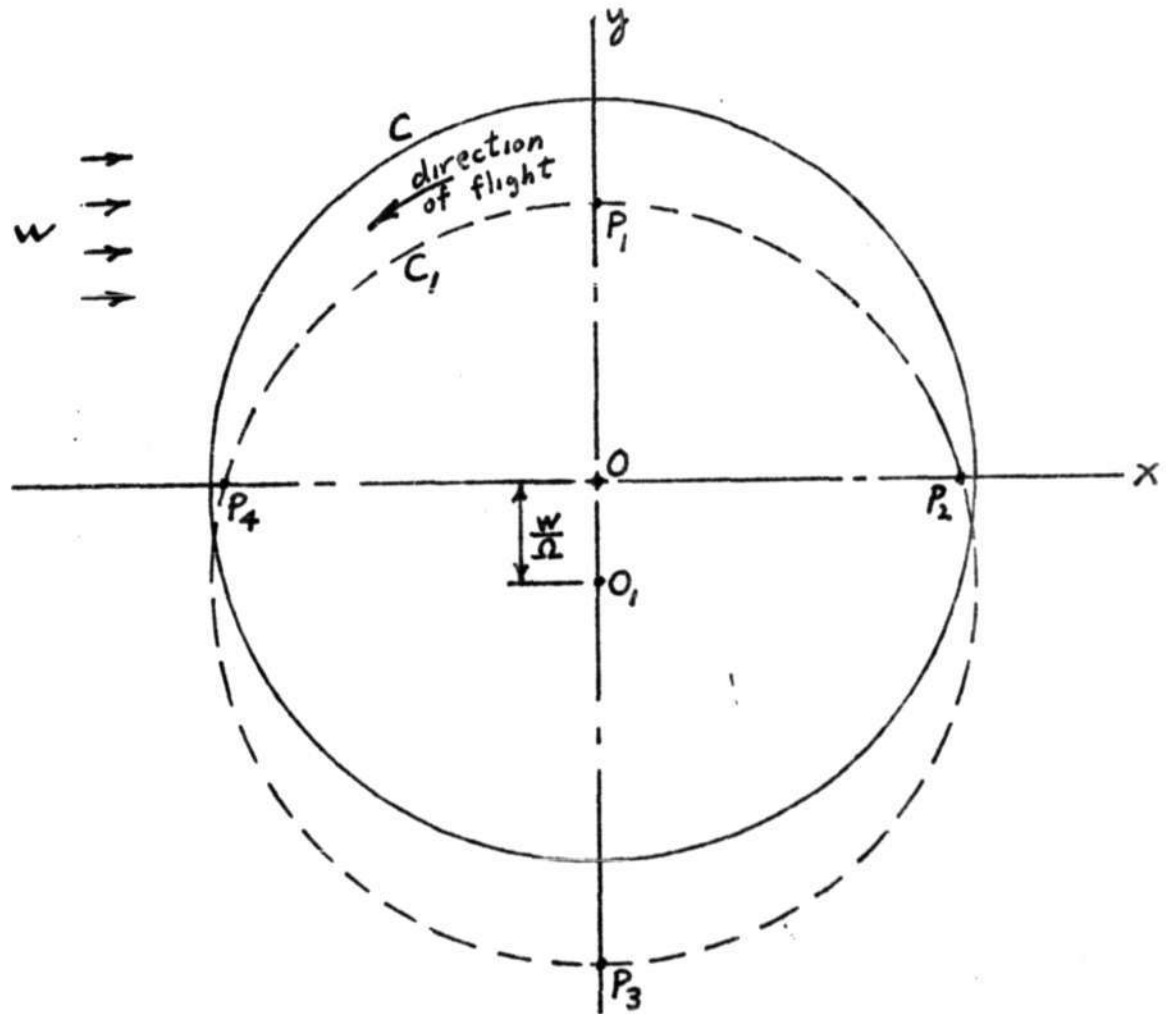

Figure 4. Change of Path to Adjust for Wind

Consider the azimuth progress rate about Ω (not O_1) when the aircraft follows C_1 in the presence of the wind. At point P_1 the ground speed is $V - w$, and the distance OP_1 is $R - OO_1 = R - \frac{w}{\Omega}$.

The azimuth rate about O is thus:

$$\dot{\theta} = \frac{V}{R} = \frac{V - w}{R - \frac{w}{\Omega}} = \frac{V - w}{\frac{V}{\Omega} - \frac{w}{\Omega}} = \Omega$$

Similarly at P_3 , $\dot{\theta} = \frac{V + w}{R + \frac{w}{\Omega}} = \Omega$,

and at P_2 and P_4 , $\dot{\theta} \approx \frac{V}{R} = \Omega$. Thus at the points where C_1 crosses the x and y axes the azimuth progress rate has the proper value.

The above procedure will be generalized for all wind directions and will be formulated as a method of heading adjustment to compensate for wind. The result will be that in place of the reference functions $\theta_1 = \Omega t$ and $\beta_1 = 0$ for no wind, the functions should be $\theta_1 = \Omega t$ and $\beta_1 = -\frac{2w}{V} \sin(\Omega t + \mu)$.

Figure 5 is similar to Figure 4 except that the wind is in an arbitrary direction, μ . The center O_1 for the circle C_1 is on a line through O perpendicular to the wind vector, and at a distance $\frac{w}{\Omega}$ from O , to the right of the wind vector. The coordinates of O_1 are:

$$x_1 = \frac{w}{\Omega} \cos \mu$$

$$y_1 = -\frac{w}{\Omega} \sin \mu.$$

The equation of C_1 is:

$$(x - \frac{w}{\Omega} \cos \mu)^2 + (y + \frac{w}{\Omega} \sin \mu)^2 = R^2 = \frac{V^2}{\Omega^2}, \dots(21.1)$$

Inserting $x = r \cos \theta$, $y = r \sin \theta$ in (21.1) it can be reduced to:

$$\frac{v^2}{\Omega^2} = r^2 + \frac{v^2}{\Omega^2} - 2r \frac{v}{\Omega} \cos(\theta + \mu) \quad \dots(21.2)$$

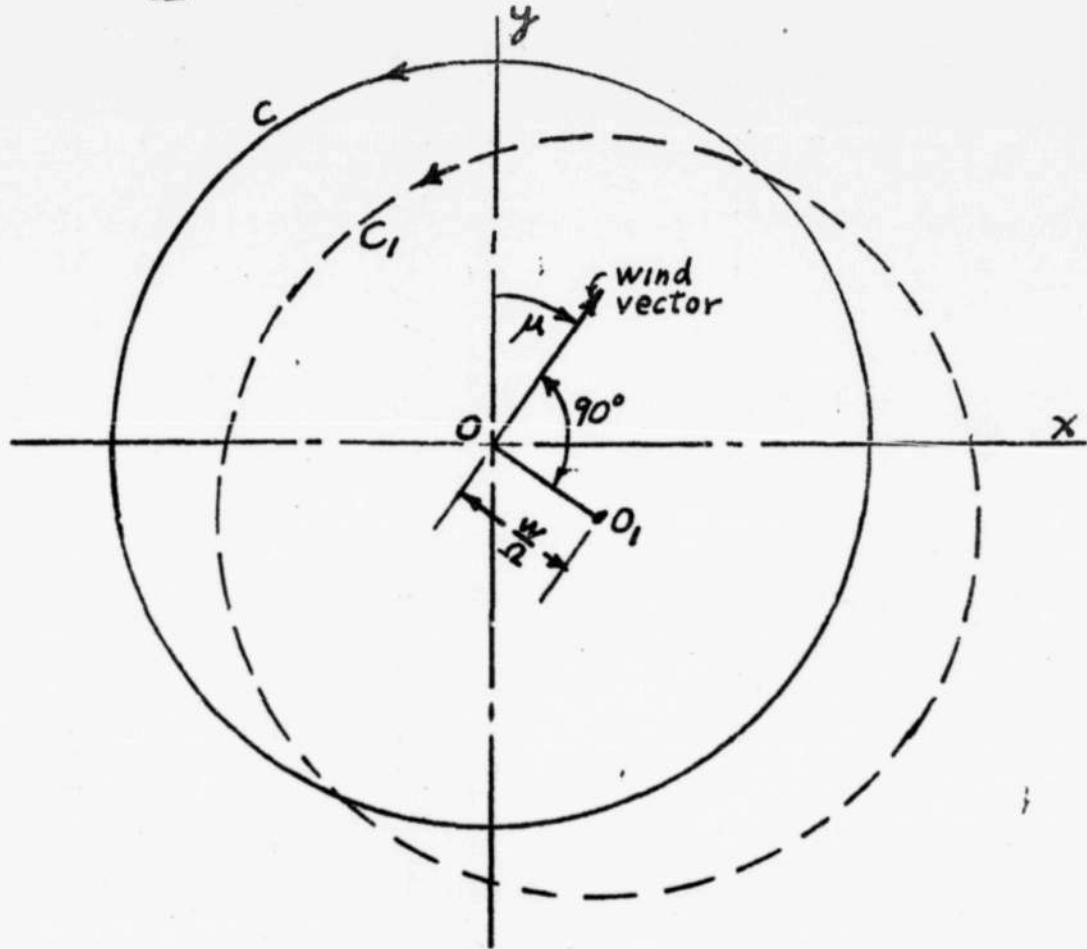

Figure 5. Change of Path to Adjust for Wind

Equation (21.2) is next linearized relative to $r_1 = \frac{v}{\Omega}$, $\theta_1 = \Omega t$, and $w_1 = 0$. This replaces (21.2) by an expression in which position on C_1 appears as a deviation from position on C :

$$0 = \frac{V}{\Omega} \dot{r} - \frac{V}{\Omega^2} w \cos(\Omega t + \mu) \quad \dots(21.2)$$

$$\text{or: } \dot{r} = \frac{w}{\Omega} \cos(\Omega t + \mu) \quad \dots(21.3)$$

(21.3) gives the linear approximation to the radial deviation of

C_1 from C . By (20.3):

$$\dot{\theta} = -\frac{\Omega^2}{V} \dot{r} + \frac{w\Omega}{V} \cos(\Omega t + \mu) \quad \dots(21.4)$$

Combining (21.3) and (21.4) we have

$$\dot{\theta} = 0 \quad \dots(21.5)$$

Thus azimuth progress on C_1 is the same as on C (within the limits of linear approximation).

Equation (20.2) may be written as:

$$\beta = \frac{\dot{r}}{V} - \frac{w}{V} \sin(\Omega t + \mu) \quad \dots(21.6)$$

Differentiating (21.3) and inserting \dot{r} in (21.6) gives:

$$\beta = -\frac{2w}{V} \sin(\Omega t + \mu) \quad \dots(21.7)$$

By using (21.7) as the heading reference function, β_1 , in place of $\beta_1 = 0$, and keeping $\theta_1 = \Omega t$, the aircraft will be guided to follow the path C_1 , thus eliminating azimuth deviation due to the measured wind. Azimuth and heading measurements remain relative to the original center, O , the point O_1 having been used only as a means of arriving at the desired result. It should be noted that the new heading reference, β_1 , is not the direction of tangency to C_1 , but rather provides the proper "crab angle" such that the ground path is C_1 .

Section 22. Appendix

To transform from ground polar coordinates to air-mass polar coordinates, or vice-versa, it is convenient to use intermediate transformations in Cartesian coordinates. The origins of the ground coordinate system and air-mass coordinate system are assumed to coincide at $t = 0$. The x and y components of wind are:

$$\begin{aligned} w_x &= w \sin \mu & (\mu \text{ is measured positive clockwise with } \mu = 0 \text{ on the } y \text{ axis.}) \\ w_y &= w \cos \mu \end{aligned}$$

Therefore the Cartesian coordinate relations are:

$$\begin{aligned} x &= x' + tw \sin \mu \\ y &= y' + tw \cos \mu \end{aligned} \quad \dots(22.1)$$

To transform the circular path in air-mass coordinates, (19.1):

$\theta' = pt$, $r' = V/p$, into ground coordinates we have

$$\begin{aligned} x &= r' \cos \theta' + tw \sin \mu = \frac{V}{p} \cos pt + tw \sin \mu \\ y &= r' \sin \theta' + tw \cos \mu = \frac{V}{p} \sin pt + tw \cos \mu \end{aligned} \quad \dots(22.2)$$

Substituting (22.2) in $r = \sqrt{x^2 + y^2}$ and $\theta = \arctan \frac{y}{x}$ gives (19.2).

Next, we need the relations which replace $\dot{r} = V \sin \beta$ and $r\dot{\theta} = V \cos \beta$ when wind is present. The compass heading, ϕ , of the aircraft axis is the same in either coordinate system (but β is not the same). We have

$$\dot{x}' = V \sin \phi$$

$$\dot{y}' = V \cos \phi$$

$$\dot{x} = V \sin \phi + w \sin \mu$$

$$\dot{y} = V \cos \phi + w \cos \mu$$

$$\dot{r} = \dot{x} \cos \theta + \dot{y} \sin \theta$$

$$= V \sin \phi \cos \theta + V \cos \phi \sin \theta + w \sin \mu \cos \theta + w \cos \mu \sin \theta$$

$$= V \sin \beta + w \sin (\theta + \mu) \quad \dots(22.3)$$

$$r\dot{\theta} = \dot{y} \cos \theta - \dot{x} \sin \theta$$

$$= V \cos \phi \cos \theta - V \sin \phi \sin \theta + w \cos \mu \cos \theta - w \sin \mu \sin \theta$$

$$= V \cos \beta + w \cos(\theta + \mu) \quad \dots(22.4)$$

Given a circular path of radius R in ground coordinates,

(22.3), with $\dot{r} = 0$, becomes:

$$\sin \beta = -\frac{w}{V} \sin (\theta + \mu) \quad \dots(22.5)$$

and by (22.4) and (22.5):

$$R \dot{\theta} = V \sqrt{1 - \frac{w^2}{V^2} \sin^2(\theta + \mu) + w \cos (\theta + \mu)} \quad \dots(22.6)$$

or:

$$\frac{dt}{d\theta} = \frac{R}{V} \frac{1}{1 - \frac{w^2}{V^2}} \left[\sqrt{1 - \left(\frac{w}{V}\right)^2 \sin^2(\theta + \mu) - \frac{w}{V} \cos(\theta + \mu)} \right] \quad \dots(22.7)$$

Exact integration of (22.7) requires use of elliptic integrals as noted in Section 19. Let $\frac{w}{V} = k$. Expansion of (22.7) in a power series in k can be used in place of elliptic integrals. The expansion is obtained easily by using the product of two series:

$$\frac{1}{1 - k^2} = 1 + k^2 + k^4 + \dots$$

$$\left[1 - k^2 \sin^2(\theta + \mu) \right]^{\frac{1}{2}} - k \cos(\theta + \mu) = 1 - k \cos(\theta + \mu) - \frac{1}{2} k^2 \sin^2(\theta + \mu) - \frac{1}{8} k^4 \sin^4(\theta + \mu) + \dots$$

(binomial expansion)

Thus (22.7) expanded in k is:

$$\frac{dt}{d\theta} = \frac{R}{V} \left[1 - k \cos(\theta + \mu) + k^2 \left(1 - \frac{1}{2} \sin^2(\theta + \mu) \right) - k^3 \cos(\theta + \mu) + \dots \right]$$

.....(22.8)

(22.8) can be integrated easily term by term. Using terms only as far as k^2 , the integral of (22.8) is (19.7) which gives good agreement with use of elliptic integrals over an adequate range of k .

Signed

Alex Orden
Alexander Orden

Approved

J. W. Forrester
J. W. Forrester

AO:lfu

BIBLIOGRAPHY

1. Air Traffic Control

"Air Traffic Control," Radio Technical Commission for Aeronautics, Special Committee 31, May 12, 1948.

Quarterly Progress Reports, No. 1 through No. 4, of the Project Whirlwind Air Traffic Control Group.

"What We Learned from the Berlin Airlift," M. A. Chaffee and R. B. Corby, Electronics, August 1949.

"System of Air Navigation and Traffic Control Recommended by RTCA," P. C. Sandretto, Electrical Communication, March 1949.

"Peak Air Carrier Movements at Airports," Civil Aeronautics Administration Report, March 1949.

2. Aircraft Dynamics and Navigation Equipment

"Theory of Flight," R. Von Mises, McGraw Hill, 1945.

"Principles of Aeronautical Radio Engineering," P. C. Sandretto, McGraw Hill, 1942.

"Progress in Dynamic Stability and Control Research," W. F. Milliken, Jr., Journal of the Aeronautical Sciences, September 1947, Vol. 14, #9, pp. 493-519.

"Flight Evaluation of VHF Omni-Range Equipment," U. S. Naval Air Test Center, Patuxent River, Maryland, Project No. TED No. PTR ML 926, June 17, 1949.
(Available from Library of Congress, Technical Information Section)

"High Stability Radio Distance Measuring Equipment for Aerial Navigation," H. Busignies, Electrical Communication, September 1948, pp. 237-243.

"The A-12 Gyropilot," P. Halpert.
Text of a lecture presented at the SAE National Aeronautic
and Air Transport Meeting, New York, April 13-15, 1948.
Printed by Society of Automotive Engineers, Inc.
29 W. 39 Street, New York, N. Y.

"Initial Flight Tests and Theory of an Experimental Parallel
Course Computer," F. J. Gross, H. A. Kay. Technical
Development Report #83, September 1948, CAA, Technical
Development, Indianapolis, Indiana.

"The Sperry Zero-Reader," S. Kellogg and C. Fragola, Aeronau-
tical Engineering Review. November 1949, pp. 22-31.

"A Study of the Effect of Winds Aloft on an Air Traffic
Control Computer," J. N. Marshall and A. B. Faunce,
Radio Corporation of America, RCA Victor Division,
Camden, New Jersey.

3. Principles of Control Systems

"Theory of Servomechanisms," Vol. 25 of the Radiation Labora-
tory Series, McGraw-Hill, 1947.

"Principles of Servomechanisms," G. S. Brown and D. P. Campbell.
John Wiley and Son, 1948.

"Fundamental Theory of Servomechanisms," L. A. MacColl.
D. Van Nostrand Company, Inc., 1945.

BIOGRAPHICAL NOTE

Alexander Orden was born in Rochester, New York on August 9, 1916, and grew up there. He attended the University of Rochester from 1933 to 1937 and received the B.S. degree with a major in Optics. From 1937 to 1939 he attended the University of Michigan and received the M.S. degree in Physics. He was then employed, on work involving the engineering-physics of aircraft engines, by the Douglas Aircraft Company for about a year, and the Wright Aeronautical Corporation for a year and a half. In 1942 he took a position as physicist with the National Bureau of Standards, and was there until August 1947. His work there was on the development of proximity fuzes. From 1947 to 1949 he was a half-time instructor in the Mathematics Department at N.I.T., and in the academic year 1949-50 was a research associate assigned to Project Whirlwind.